

B-1 Two Strut Coil Tie and B-2 Four Strut Coil Tie

Dayton Superior B-1 and B-2 Coil Ties are strong, versatile resistance welded ties designed to take the abuse encountered in medium and heavy concrete construction. The coil tie is an extremely simple tie that is capable of servicing many applications and uses in the field. It can be used with or without cones or combined with coil rod to form an adjustable tie. The coil threads are fast acting and self-cleaning.

B-2 Four Strut Coil Tie Couplers are available and are used in conjunction with D-18 Inside Rods to compensate for form variations.

To determine the required coil tie length, subtract two times the desired or specified setback from the wall thickness. [Wall thickness - (2x setback) = coil tie length].

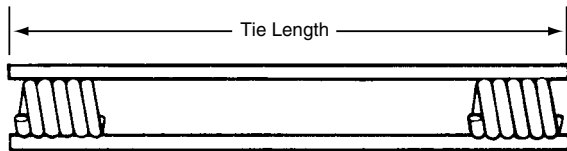

B-1 Two Strut Coil Tie

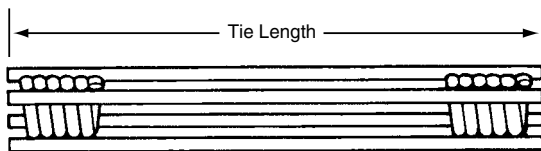

B-2 Four Strut Coil Tie and B-2 Four Strut Coil Tie Coupler

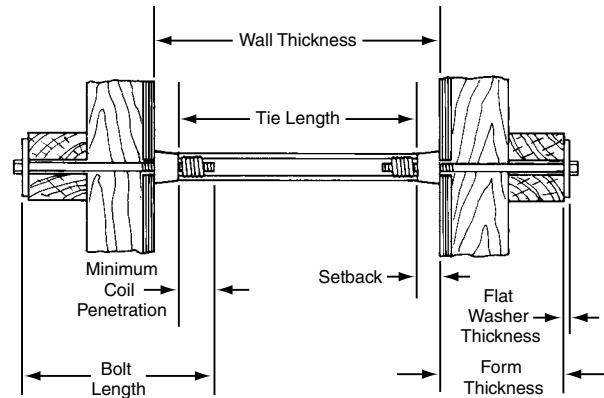

Coil Tie with Loose (Spreader) Cones

Cones are generally used when wall thickness is very thick or an architectural finish is specified.

B-1 and B-2 Coil Tie Selection Chart			
Type	Bolt Diameter	Number of Strut Wires	Safe Working Load Tension (lbs.)
B-1 Standard	1/2"	2	4,500
B-1 Heavy	1/2"	2	6,750
B-1 Standard	3/4"	2	6,750
B-1 Heavy	3/4"	2	9,000
B-1 Standard	1"	2	13,500
B-2 Standard	1"	4	18,000
B-2 Standard	1-1/4"	4	27,000
B-2 Coupler 8"	1/2"	4	9,000
B-2 Coupler 12"	3/4"	4	18,000

SWL provides a factor of safety of approximately 2 to 1.
Warning: See Page 62 for minimum bolt length.

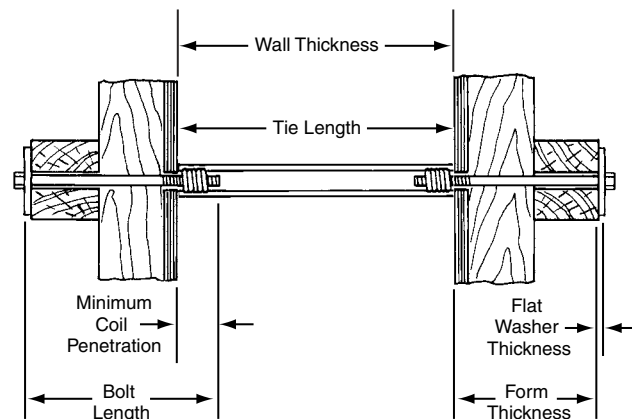

Coil Tie as Spreader and Tie

The coil tie can be used as a combination tie and form spreader when it is not necessary to keep the ends of the tie back from the face of the concrete. If a number of form reuse is contemplated, standard cut washers should be used at the tie ends to protect the form face.

To Order:
 Specify: (1) quantity, (2) name, (3) safe working load, (4) bolt diameter, (5) tie length, (6) wall thickness, (7) setback.

Example:
 3,000 pcs. B-1 Standard Coil Tie, 4,500 lbs. SWL, 1/2" diameter, 12" long for a 14" wall, 1" setback.