

# CONDENSED

## PRODUCT HANDBOOK



## Quick Reference Index

Bar Supports, Aztec.....	21	Form Anchorage.....	11	Inserts.....	13
Bar Supports, Other.....	20	Form Hangers.....	12	Precast.....	26
Bridge Deck Hangers.....	15	Forming - Heavy.....	8	Prestress Strand Restraining	
Chemical and Cement Products.....	31	Forming - Light.....	5	Devices.....	29
Chemical and Cement -		Forming - Other/Acessories.....	14	Rebar Splicing.....	18
Select Products.....	32	General and Technical Information ...	4	Tilt-up.....	23
				Screeding.....	30

## Product Index

Adjustable Coil Bolt.....	9	Fill Type Screed Bases.....	30	Prestress Strand Restraining Devices.....	29
Adjustable Half Hanger.....	15	Flared Coil Loop Insert.....	11	Quick Release Strongback.....	25
Adj. Half Hanger, Type 1-A.....	16	Flat Ties.....	5	Rebar Splicing Products.....	18
Adjustable Joist Hanger.....	17	Flat Washer.....	9	Repair Mortars.....	34
Adjustable Kicker.....	6	Fleet-Lift Anchors.....	26	Rock Anchor.....	11
Adjustable Weld Angle Bracket.....	11	Fleet-Lift Forged Erection Anchor.....	26	Rod Clamps.....	14
All-Wire Saddle Hanger.....	12	Fleet-Lift Hardware.....	26	Round Stake.....	30
Aztec Bar Supports.....	21	Fleet-Lift Inserts.....	26	Rustications.....	28
		Fleet-Lift Recess Members.....	27		
Bar Chairs.....	20	Formliners.....	28	Scaffold Bracket.....	7
Bar-Lock Couplers.....	19	Form Anchoring Products.....	11	Screed Bases.....	30
Bar Supports.....	20	Form Hangers.....	12	Screed Key Joint.....	30
Batter Washer.....	10	Form Release.....	32	Screeding Products.....	30
Beam Bolster.....	20	Four Strut Coil Insert.....	13	Screw Anchor/Bolt.....	11
Bonding Agents.....	33			She-Bolt.....	9
Brace Inserts.....	24	Gang Form Panel Ties.....	6	Shelf Angle Insert.....	13
		Ground Rel. Lifting Hardware.....	23	Shimpaks.....	28
CCL Anchors and Chucks.....	29	Ground Rel. Lifting Insert.....	23	Slab Bolster.....	20
CCL Jack and Pump.....	29	Gyro Tilt Plus Hardware.....	23	Snap Ties.....	5
Channel Saddle Hanger.....	12	Gyro Tilt Plus Inserts.....	23	SpeedStep Bracket.....	14
Chemicals.....	31			Speedy Bracket.....	6
Coil Anchor.....	24	Heavy Forming Products.....	8, 9, 10	Speedy Tie.....	6
Coil Bolt.....	9	Heavy Steel Wedge.....	5	Splicing Products.....	18
Coil Half Hanger.....	12	He-Bolt.....	10	Star Insert.....	25
Coil Hanger, Saddle Type.....	12			Steel Forms for Precast.....	29
Coil Loop Insert.....	13	Individual High Chairs.....	20	Stiffback Bracket.....	6
Coil Nut.....	9	Inserts.....	13	Strongback Anchor Bolt.....	25
Coil Rod.....	8	Inside Tie Rods.....	9	Superior Lift System.....	24
Coil Rod Hanger.....	15, 16			Superior Lift System - Hardware.....	24
Coil Ties.....	8	Jahn "A" Bracket.....	7	Sure Guard Rail Post System.....	7
Continuous High Chairs.....	20	Jahn Corner Lock.....	7	Sure-Snap Hex Head Tie.....	5
Corewall Slotted Insert.....	28	Joint Sealants.....	33	Sure-Lock Tie.....	6
Couplers.....	18	Joist Chair.....	20	Swift Lift Anchors.....	26
Cradle Heads.....	30			Swift Lift Lifting Eyes.....	26
Crimped		Lifting Angle.....	25	Swift Lift Recess Members.....	26
Pigtail Anchor.....	11	Light Forming Products.....	5, 6, 7	Swivel Lift Plate.....	25
Cure/Cure & Seal.....	32,33	Liquid Chemicals.....	33		
		Liquid Hardners.....	32	Taper Lock.....	19
Dayton Bar.....	14	Loop Ferrule Insert.....	13	Taper Ties.....	10
Deck Forming Hangers.....	15, 16, 17	Loop Panel Ties.....	6	Thin Slab Ferrule Insert.....	13
Delta Tie Insulated Panel Tie.....	28			Thread Bar - She Bolts.....	10
Disposable Void Former.....	28	Magnets.....	29	Thread Bar Taper Ties.....	10
Double Tee Anchor.....	27	Nut Washer.....	14	Threaded Rebar.....	19
Dowel Bar Splicer.....	19			Tilt-Up 3 Lifting Hardware.....	23
Dowel Baskets.....	22	Overhang Brackets.....	17	Tilt-Up 3 Lifting Insert.....	23
Dayton Shear Resistance (DSR) System.....	18			Tilt-Up Products.....	23, 24
		Pencil Rod.....	14	Turnbuckle Form Aligner.....	5
D/R Euro Thread Bar.....	8	Plastic Bar Supports (Aztec).....	21		
D/R Hex Coupler.....	8	Plastic Cone Snap Ties.....	5	Underlayments.....	34
D/R Hex Nut - Cast.....	8	Plate Saddle Hanger.....	12	Utility Anchors.....	27
D/R Hex Nut - Steel.....	8	Precast Products.....	26, 28	Utility Anchor Setting Plugs.....	27
D/R Swivel Wing Nut.....	8	Pres-Steel Half Hangers.....	15		
D/R Thread Bar.....	8	Pres-Steel Half Hangers 45°.....	16	Wall Braces.....	24
D/R Wing Nut.....	8	Pres-Steel Hanger, Type 1.....	15	Water Repellents.....	33
Ductile Embed.....	13	Pres-Steel Hanger, Type 2.....	15	Wedge Hanger.....	12
Duroweb Shear Reinforcement.....	29	Pres-Steel Hanger, Type 4.....	15	Wedge, Heavy Steel.....	5
		Pres-Steel Hanger, Type 4A.....	16	Wing Nut.....	10
Edge Lifting Plate.....	25	Pres-Steel Hanger, Type 5.....	15		
End Anchor.....	18	Pres-Steel Hanger, Type 5A.....	16		
Epoxies.....	33	Pres-Steel Hanger, Type 7.....	15		
Expanded Coil Inserts.....	13				

**Note:** This "condensed" catalog displays only a small portion of Dayton Superior quality concrete accessories. For additional in-depth product information, contact a Dayton Superior Service Center or Technical Services Department. Locations are listed on the back cover.

## Dayton Superior - We're Here To Meet Your Needs...

Dayton Superior Concrete Accessories is one of the fine construction related divisions of the Dayton Superior Corporation. By combining quality products, service and expertise, Dayton Superior is able to serve the needs of the concrete construction industry quickly and efficiently.

Dayton Superior offers the industry the most comprehensive line of concrete accessories and construction chemicals. Dayton Superior has a full complement of accessories and equipment for light and heavy forming, form and deck hangers, inserts and anchors, rebar supports, precast, tilt-up and rebar splicing. All told, there are over 5,000 standard concrete accessory products and construction chemicals. Dayton Superior also has the capability to design and fabricate special concrete accessory items, when the need presents itself.

Dayton Superior has combined service of over 200 years in the concrete accessory field and technical expertise ready to assist you with any concreting problem that may arise. Quality products, experience, coast-to-coast plants and service centers and the industry's largest dealer network - available to you as a valued Dayton Superior customer.

## Safety Notes and Product Application

Do not use any Dayton Superior product before reading and understanding the product instructions in the appropriate Dayton Superior product publication. For maximum safety, product information must be extended to field personnel. Contractors must make sure that their employees are properly instructed in the use and installation of all concrete accessories.

The safety factor applied to a particular product is a variable, dependent on the degree of hazard or risk involved in the application of that product. In concrete construction, various job site conditions can often increase the degree of risk. Concentrated loads on the formwork, unsymmetrical placement of concrete, using a crane inadequate for the job, uplift, impact, use of motorized carts, formwork height, jerking the crane during lifting or handling, are job site conditions that may raise the degree of risk. Dayton Superior lists minimum safety factors. If a job site condition exists that increases job site risks, such as those previously stated, the user must increase the product safety factor to compensate for the job site conditions.

Dayton Superior develops products for the concrete construction industry and has stressed that the products it supplies meet or exceed all pertinent safety requirements. All tests on the products shown in this publication have been performed by Dayton Superior or independent testing laboratories.

Dayton Superior recommends that the provisions of the American National Standards Institute (Standard ANSI A 10.9), Occupational Safety and Health Administration (OSHA Part 1926) and American Concrete Institute (ACI 347 Guide to Formwork for Concrete) be strictly followed when considering safety factors and safe working loads. The minimum safety factors listed in the table below are a guide and should not be compromised. When unusual job conditions exist, these minimum safety factors must be increased by the user.

## Safety Factors

Dayton Superior recommends the following minimum safety factors and the provisions of OSHA Part 1926 and ANSI 10.9 when considering safety factors.

Accessory	Minimum Safety Factor	Type of Construction
FORM TIES	2.0	All Applications
FORM ANCHORS	2.0	Formwork supporting form weight and concrete pressures only
	3.0	Formwork supporting weight of forms, concrete, live loads and impact
FORM HANGERS	2.0	All Applications
ANCHORING INSERTS (Used as form ties)	2.0	Precast concrete panels when used as formwork
LIFTING INSERTS	2.0	Tilt-up concrete panels
	4.0	Precast concrete elements

If a different safety factor is required for any reason, a product's safe working load must be changed accordingly. The following equation is used to increase or reduce a safe working load.

$$\text{New Safe Working Load} = \frac{\text{Original Working Load} \times \text{Original Safety Factor}}{\text{New Required Safety Factor}}$$

**Note:** Users of Dayton Superior products must evaluate the product application, calculate induced loads, determine the necessary safety factor, calculate the safe working load and then control field conditions to prevent application of loads in excess of the calculated safe working loads.

## A-2 Plastic Cone Snap Ties

Dayton Superior's Plastic cones can be added to A-3, A-4, A-44, A-46 or A-48 ties and act as positive form spreaders to aid in reducing concrete leakage. Plastic cones are available in 1", 1-1/4" and 1-1/2" nominal setbacks.

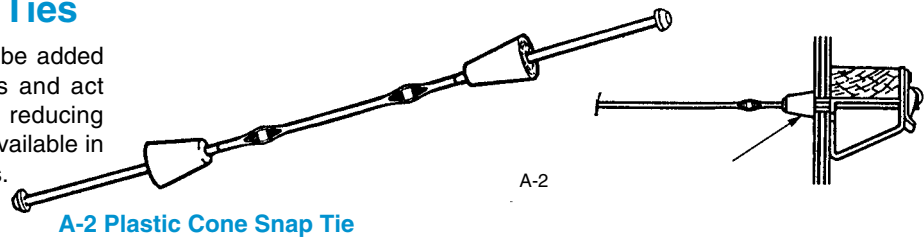

## A-3 Snap Tie Standard & Heavy

Dayton Superior's A-3 Snap Ties, Standard and Heavy are equipped with 15/16" flat washers and are manufactured for specified wall thicknesses. A-3 Snap Ties provide a 1" breakback from the concrete surface. Other breakbacks are available on special order.

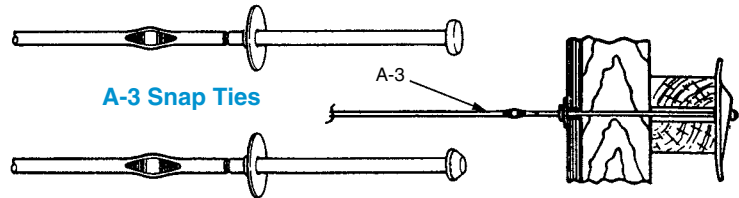

## A-4 Sure-Snap Hex Head Tie

Dayton Superior's A-4 Sure-Snap Hex Head Tie is produced with hot forged hexagon heads that permit easy breakback of short-end snap ties while the formwork is still in place.

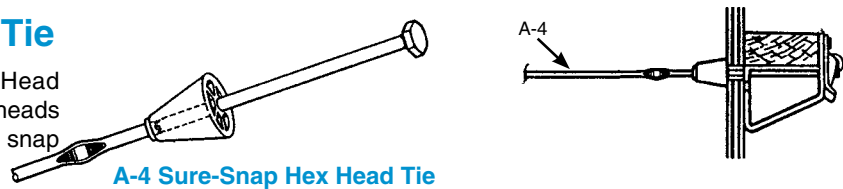

## A-16 Omni Wedge

Dayton Superior's A-16 Heavy Steel Wedge is used with any standard or heavy Dayton Superior's Snap Tie to provide a quick and easy wedging action to securely hold the tie and formwork in place.

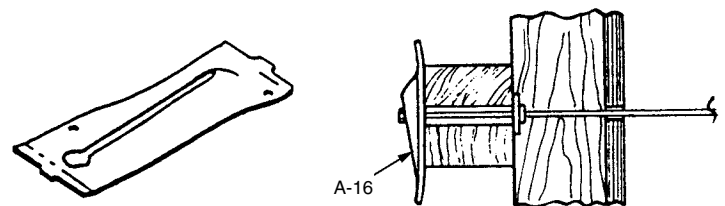

## A-21 Flat Ties

Dayton Superior's A-21 Flat Ties are available in several styles and breakbacks for use with various modular steel frame forming systems.

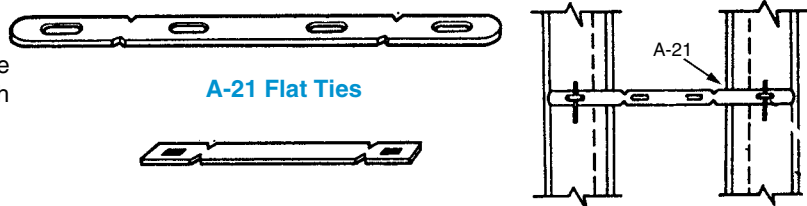

## A-27 Turnbuckle Form Aligner

Dayton Superior's A-27 Turnbuckle Form Aligner is designed to align and position all types of vertical forms. It is combined in the field with any size stud to allow easy adjustment for final form positioning and alignment.

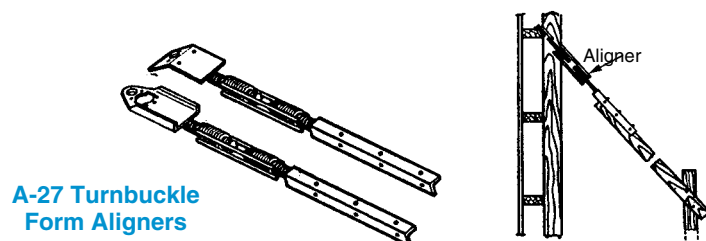

## A-28 Adjustable Kicker

The Adjustable Kicker is the only steel brace that attaches to wood or steel forms and can be used on dirt, wood, or concrete surfaces. The quick adjustability allows for a faster, straighter wall line with zero waste. With three standard sizes - 8", 12", 16" and custom sizes available, it can withstand up to a two foot pour. When the job is completed, it detaches and folds down for the next application.

With an available bracket, the Adjustable Kicker quickly attaches to Steel-Ply and curb forms.

**A-28 Adjustable Kicker**  
Patent #5817247

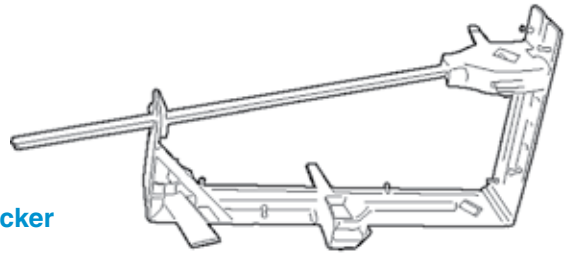

## A-46 Loop Panel Ties, Standard and Heavy

Dayton Superior's A-46 Loop Panel Ties are designed for use with standard modular panel forming systems; available with various breakbacks, plastic cones and/or water resistant washer.



**A-46 Loop Panel Tie**

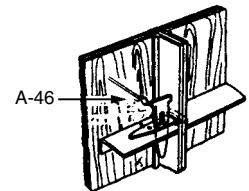

## A-48 Gang Loop Panel Ties, Standard & Heavy

Dayton Superior's A-48 Gang Loop Panel Ties are similar to the A-46 Ties, above, but have longer ends to allow them to be used with various modular systems' gang form bolts.

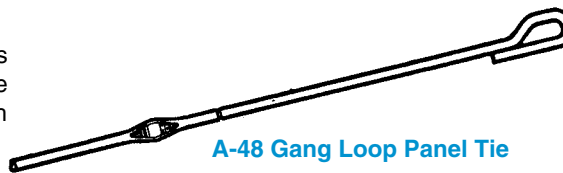

**A-48 Gang Loop Panel Tie**

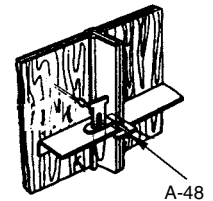

## A-55 Sure-Lock Tie

Dayton Superior's A-55 Sure-Lock Tie is a short-end loop tie fitted with high-impact, self-centering plastic cones. The A-55 Sure-Lock Tie is used with the A-56 Sure-Lock Clamp or the A-56-A Speedy Bracket, shown below, for loose plywood forming.

**A-55 Sure-Lock Tie**

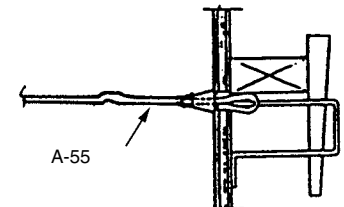
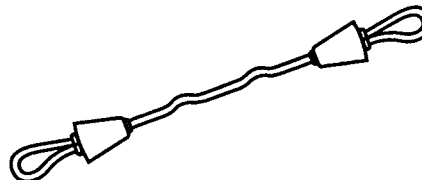

## A-56 Sure-Lock Bracket and A-56-A Speedy Bracket

Dayton Superior's A-56 Sure-Lock Bracket and A-56-A Speedy Bracket are rugged units designed to accept the A-55 Sure-Lock Tie. They will accommodate a single 2x4, 3x4 or 4x4 waler; horizontally or vertically.

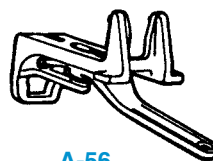

**A-56**

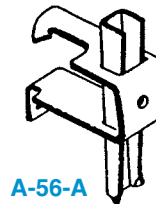

**A-56-A**

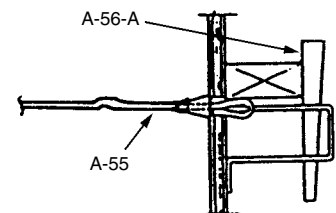

**A-56 and A-56-A Short-End Loop Tie Brackets**

## A-57 Sure-Lock Strongback Clamp and A-57-A Stiffback Bracket

Dayton Superior's A-57 Sure-Lock Strongback Clamp and A-57-A Stiffback Bracket are used in conjunction with the Sure-Lock Bracket or the Speedy Bracket, respectively, to securely hold 2x4 strongbacks to the form. This provides added strength and alignment to the form.

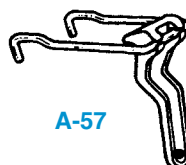

**A-57**

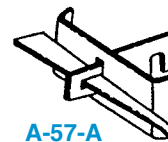

**A-57-A**

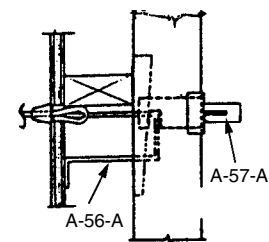

**A-57 and A-57-A Strongback Brackets**

## A-81 Jahn “A” Bracket

Dayton Superior’s A-81 Jahn “A” Bracket is designed to be used with any standard Dayton Superior short-end snap tie. This durable bracket can be used with horizontal walers or vertical studs.

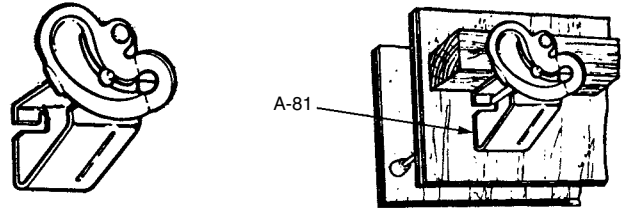

A-81 Jahn “A” Bracket

## A-82 Jahn “C” Bracket

Dayton Superior’s A-82 Jahn “C” Bracket is used to attach vertical strongbacks to the formwork for added strength and alignment.

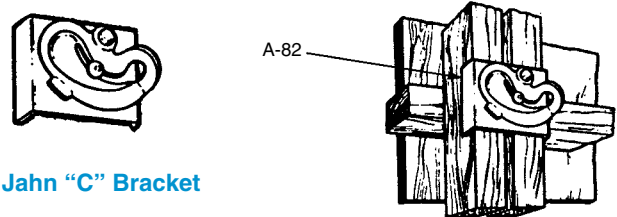

A-82 Jahn “C” Bracket

## A-90 Scaffold Bracket

Dayton Superior’s A-90 Scaffold Bracket is used to support scaffolding on nearly any type of formwork. It can be flush mounted or adjusted to fit the various size vertical or horizontal walers or strongbacks. The Scaffold Bracket has a safe working load of approximately 1,000 pounds.

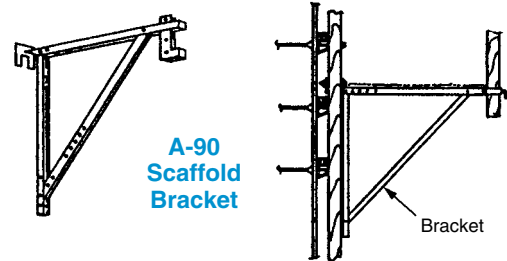

A-90 Scaffold Bracket

## A-93 Sure Guard Rail Post System

The Sure Guard Rail Post System opens wide and tightens quickly, allowing for application to practically any project. The post is easily installed utilizing a top adjusting wing nut which creates the ability to tighten from a standing position. A specially designed base adds to the simplicity of setup with predrilled holes providing trouble-free fastening to decks.

This post can adjust to any floor slab thickness between 4” - 29”. A drop pin makes the Sure Guard Rail Post System simple and efficient to use. The 30 lb. Sure Guard Rail Post System is also hot-dipped galvanized for durability and designed to withstand the toughest jobsite conditions.

**\*WARNING:** Rail Post must be secured to deck with proper fasteners to ensure complete safety.

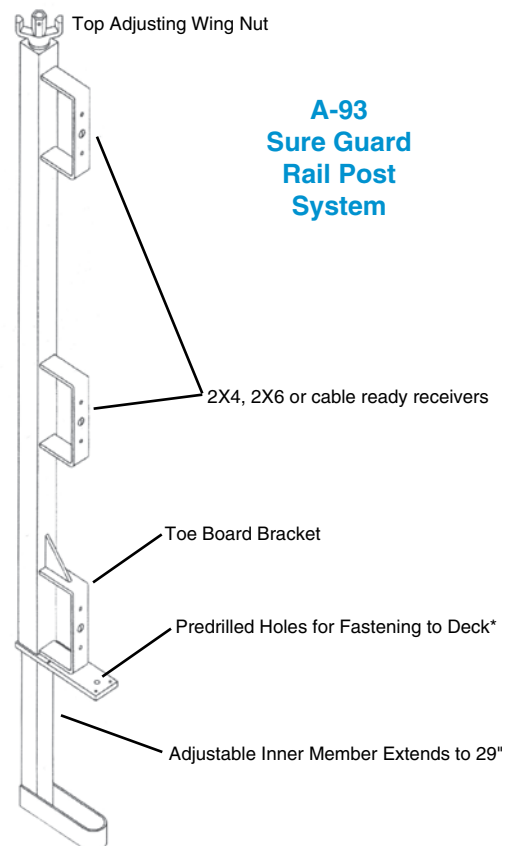

A-93 Sure Guard Rail Post System

## B-1, B-2, B-3 Coil Ties

Dayton Superior's Coil Ties are strong, resistance welded ties designed for medium and heavy forming applications. Coil tie products are available in two or four struts, with screw-on plastic cones and water-resistant versions. 1/2", 3/4", 1" and 1-1/4" diameters are available.

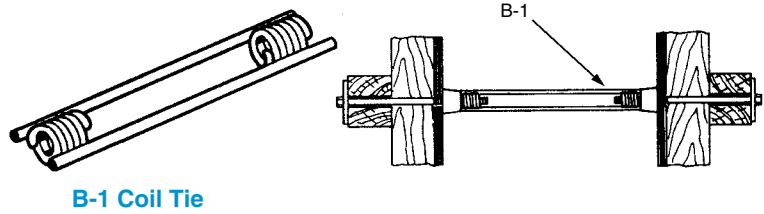

B-1 Coil Tie

## B-12 Coil Rod

Dayton Superior's B-12 Coil Rod is continuous coil threaded rod available in 1/2" to 1-1/2" diameters in 1/4" increments. Available in special cut-to-length sizes or in standard 12' lengths, Coil Rod and threaded bar are used with other coil tie products in many different combinations and applications.

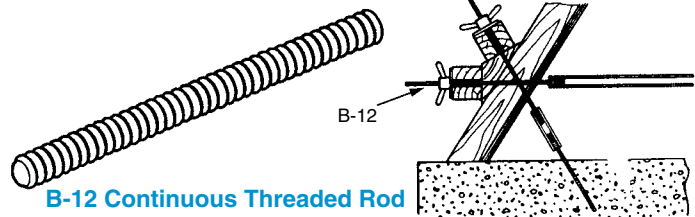

B-12 Continuous Threaded Rod

## B-12-A D/R Thread Bar and B-12-AD D/R Euro Thread Bar

Dayton Superior's D/R Thread Bar is a high strength, 5/8" and 7/8" ductile steel with a full length, cold-rolled contour thread. The bar's 2-1/2 threads per inch offers fast installation and stripping. D/R Thread Bar is available in 20'-0" standard lengths and can be cut to specific project requirements. Field cutting, with Carborundum blades, is easily accomplished without thread damage.

The D/R Euro Thread Bar is a hot-rolled high strength steel with two flat sides in the thread pattern. This bar has been used in Europe on all types of projects for years. The flat sides provide self-cleaning and allow a gripping surface for turning the bar. Euro Thread Bar is available in both 15mm (5/8") and 20mm (7/8") diameters and is standard in 19'-8" lengths. Euro Thread Bar is bendable.



B-12-A D/R Thread Bar

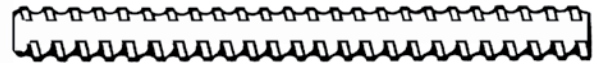

B-12-AD D/R Euro Thread Bar

## B-12-ACN Cast Hex Nut and B-12-ASN D/R Steel Hex Nut

5/8" and 7/8" hex nuts, in cast and steel versions, are available with 2-1/2 threads per inch to be used in conjunction with the appropriate D/R Thread Bar.

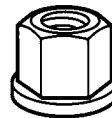

B-12-ACN Cast Hex Nut

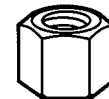

B-12-ASN Steel Hex Nut

## B-12-AW D/R Wing Nut and B-12-ASW D/R Swivel Wing Nut B-12-AWN D/R Cast Nut Washer

5/8" and 7/8" Wing Nut is a high strength malleable steel nut with 2-1/2 threads per inch for use with the D/R Thread Bar. For added versatility, the Swivel Wing Nut features a heavy duty, ribbed washer base, reducing the number of loose working parts required.

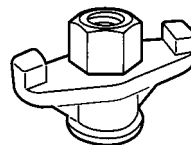

B-12-AW Wing Nut

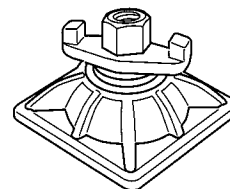

B-12-ASW Swivel Wing Nut

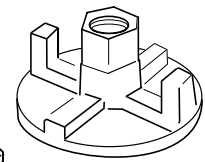

B-12-AWN D/R Cast Nut Washer

## B-12-AC D/R Hex Coupler

5/8" and 7/8" Hex Couplers are available to couple two D/R Thread Bars. The Hex Coupler is supplied with 2-1/2 threads per inch and a positive stop.

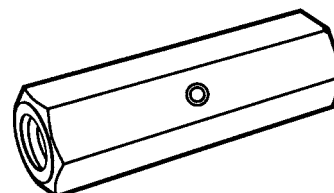

B-12-AC Hex Coupler

## B-14 Coil Bolt

Dayton Superior's B-14 Coil Bolts are hex head bolts threaded for the contour of the coil tie helical coil. Available in 1/2", 3/4", 1", 1-1/4" and 1-1/2" diameter and length as required in 1" increments.

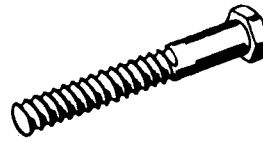

B-14 Coil Bolt

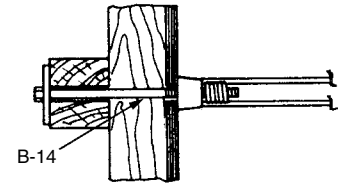

## B-14-A Adjustable Coil Bolt

Dayton Superior's B-14-A Adjustable Coil Bolt is adaptable for special applications at corners, batter walls, etc., where one-size Adjustable Coil Bolt may replace several different lengths of the standard Coil Bolt.

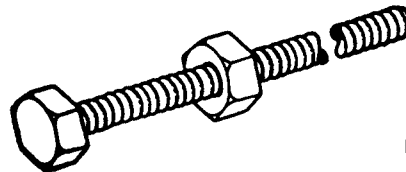

B-14-A Adjustable Coil Bolt

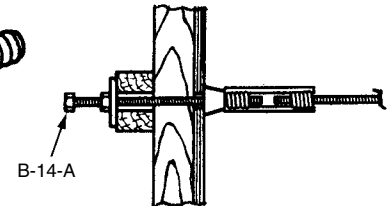

## B-11 Flat Washer

Dayton Superior's B-11 Flat Washers - flat steel plate available in sizes to fit all coil bolt, she-bolt and taper tie applications.

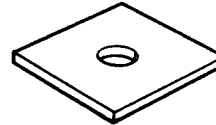

B-11 Flat Washer

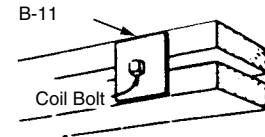

## B-13 Coil Nut and B-32 Handle Coil Nut

Dayton Superior's B-13 Coil Nut and B-32 Handle Coil Nut are available in 1/2", 5/8", 3/4", 7/8", 1", 1-1/8", 1-1/4" and 1-1/2" diameters with coil thread. The Handle Coil Nut eliminates the need for a wrench and makes installation and stripping fast and simple.



B-13

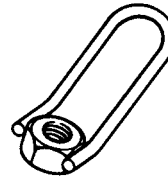

B-32

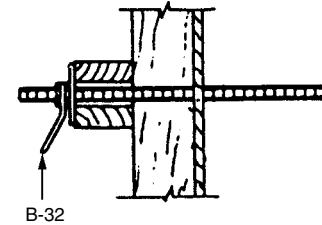

B-13 Coil Nut & B-32 Handle Coil Nut

## D-2, D-30 She-Bolts

Dayton Superior's She-Bolts are high strength units suitable for heavy concrete construction. Manufactured with either Acme or Coil external threads, for use with gang and/or steel forms. She-Bolts are used in conjunction with inside tie rods (D-1, D-18).

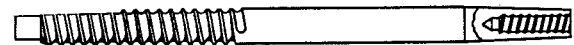

D-2 She-Bolt

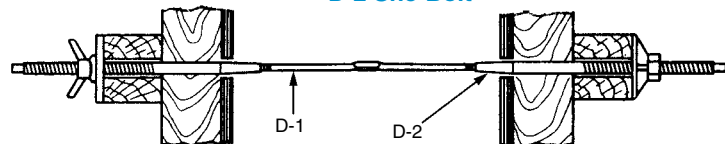

## D-1, D-18 Inside Tie Rods

Dayton Superior's D-1 and D-18 Inside Tie Rods for She-Bolts are manufactured in three styles; plain, with flats and continuous threaded. Positive stops and/or water-resistant models are available.



Standard D-1



Standard D-18

Flat - Location May Vary

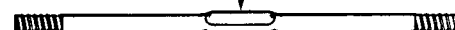

D-1 with Flat

## D-30-A Thread Bar She-Bolts

Dayton Superior's DS Thread Bar She Bolts are heavy duty, reusable form ties for medium and heavy concrete construction. Two she bolts are used with a length of DS Thread Bar to tie formwork for any wall thickness. D-30-A She Bolts are available in 5/8" and 7/8" diameter. Other sizes available on request.

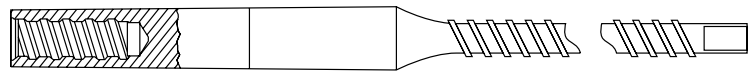

D-30-A Thread Bar She-Bolt

## D-9, D-19 Taper Ties

Dayton Superior's D-9 and D-19 Taper Ties are used where specifications permit complete removal of the form tie from the concrete. They are manufactured with either Acme or coil thread and with up to 90° of taper.

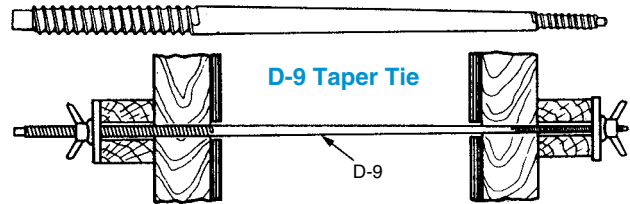

D-9 Taper Tie

## D-9-A Thread Bar Taper Ties

Dayton Superior DS Thread Bar Taper Ties (D-9-A) are used when specifications require or permit complete removal of the form tie from the concrete. The D-9-A features the DS Thread Bar's 2-1/2 threads per inch for rapid installation and stripping. Standard 5/8" and 7/8" diameter taper ties are available in 42", 50" and 58" overall length. 7/8" diameter taper also available in 66" overall length.

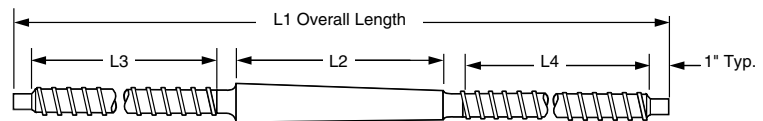

D-9-A Thread Bar Taper Tie

## D-40 He-Bolt

He-Bolts are used in conjunction with one of the many form anchorage units to provide an economical method of anchoring cantilever forms.

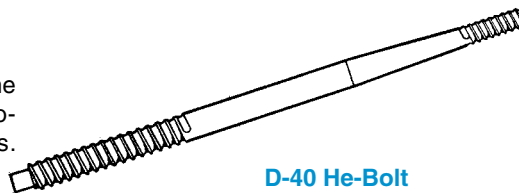

D-40 He-Bolt

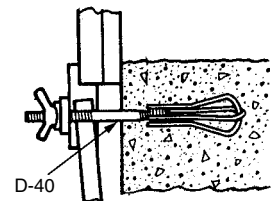

## B-39 Wing Nut

Dayton Superior's B-39 Wing Nuts are available in 1/2" through 1-1/2" diameters. Wing Nuts are normally supplied with coil threads. Acme thread is available on special order. Wing Nuts are typically used with she-bolts, he-bolts, taper ties and through bolting in heavy forming applications.

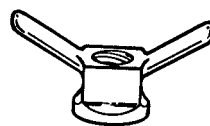

D-39 Wing Nut

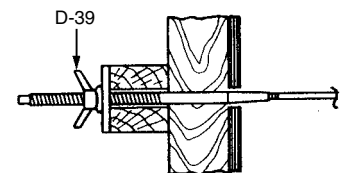

## B-42, D-22 Batter Washer

Dayton Superior's B-42 Batter Washers are designed to swing freely to any desired angle up to 45°. They are available in 1/2" through 1-5/8" diameters. Nail holes permit nailing to the waler and multiple grips on the underside help prevent slippage.

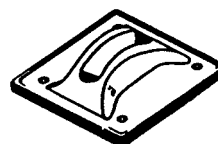

B-42 Batter Washer

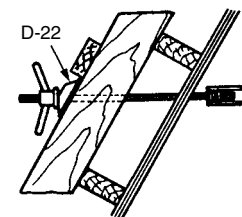

## B-18, B-33, B-43 Flared Coil Loop Inserts

Dayton Superior's Flared Coil Loop Inserts are used with coil thread bolts to effectively anchor formwork. Available in several configurations with 3/4", 1", 1-1/4" and 1-1/2" diameter coil thread.

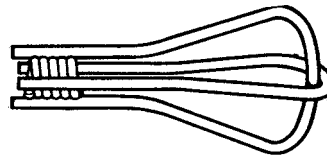

B-33 Flared Coil Loop Insert

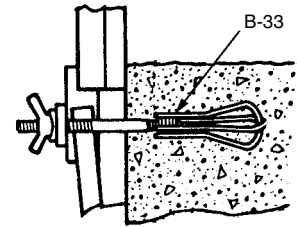

## D-34 Crimped Pigtail Insert

Dayton Superior's D-34 Crimped Pigtail Anchors are used for forming anchorage in mass concrete. Manufactured in 1/2" through 1" diameters with coil or NC machine thread.



D-34 Crimped Pigtail Anchor

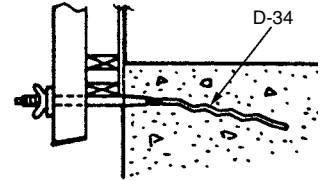

## D-24 Adjustable Weld Angle Bracket

Dayton Superior's D-24 Adjustable Weld Angle Bracket is designed to tie single-sided forming to steel piles, metal beams, etc. The brackets provide 110° of bolt adjustability and are available in 1/2", 5/8", 3/4", 7/8", 1" and 1-1/8" diameters.

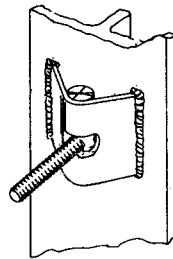

D-24 Adjustable Weld Angle Bracket

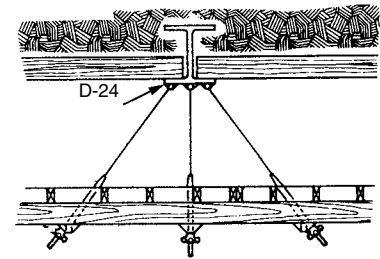

## B-31 Rock Anchor

Dayton Superior's B-31 Rock Anchor is designed for use in sound rock or concrete to secure one-sided forming. Available in 1/2", 3/4" and 1" nominal diameters with coil thread.

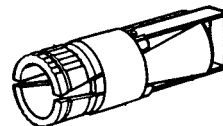

B-31 Rock Anchor

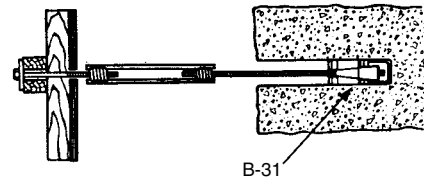

## F-1 Screw Anchor and F-2 Screw Anchor Bolt

Dayton Superior's F-1 Screw Anchor is a helical coil used in conjunction with the skein thread F-2 Screw Anchor Bolt. Available in 3/4" to 2" diameters, the screw anchor is very effective supporting cantilever forms and transferring the bolt load into the concrete.

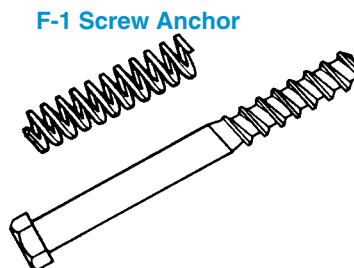

F-2 Screw Anchor Bolt

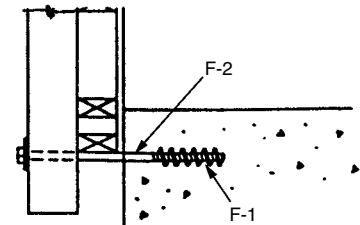

## C-1-B, C-1-C Wedge Hanger

Dayton Superior's Wedge Hangers are standard snap ties bent to fit over the flanges of a steel beam to support deck formwork. Standard breakback is 1", other breakbacks can be furnished on special order.

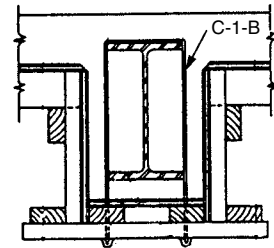
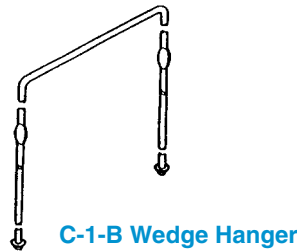

## C-2 Coil Hanger, Saddle Type

Dayton Superior's C-2 Coil Hanger is similar to the Wedge Hanger, above. It utilizes a two strut coil tie to support heavier forming loads.

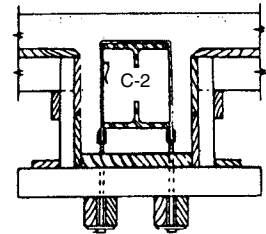
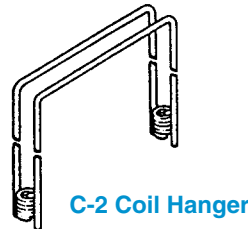

## C-3 Coil Half Hanger

Dayton Superior's C-3 Coil Half Hanger is designed to be welded to an exterior steel beam or bent around an exterior steel beam flange to support double ledgers.

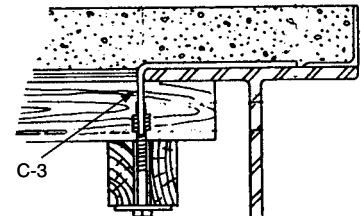
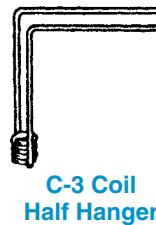

## C-13 Plate Saddle Hanger

Dayton Superior's C-13 Plate Saddle Hanger is placed over a beam to provide support for joists on both sides of the beam. Plate Saddle Hangers can be ordered with any drop and/or beam width to fit the application.

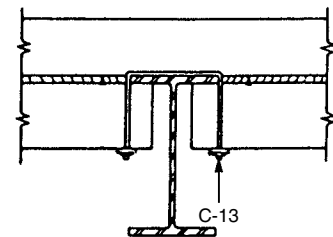
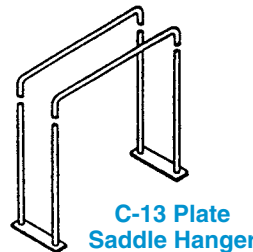

## C-13-A All-Wire Saddle Hanger

Dayton Superior's C-13-A All-Wire Saddle Hanger is similar in design and function to the C-13 above but without the plate.

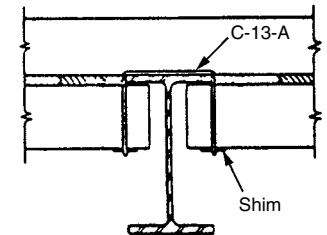

## C-14 Channel Saddle Hanger

Dayton Superior's C-14 Channel Saddle Hanger is similar in design and use as the C-13 Hanger above but utilizes channels in place of the plates to reduce crushing of wood joists.

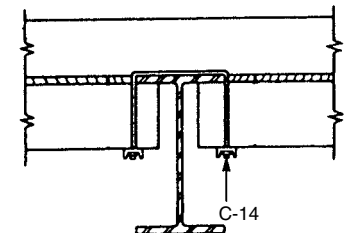
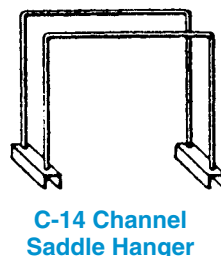

## B-16, B-17, B-18, B-33 Coil Loop Inserts

Dayton Superior's Coil Loop Inserts are made of a single looped wire welded to a helix coil. They are available in 1/2" to 1" diameters suitable for many concreting applications.

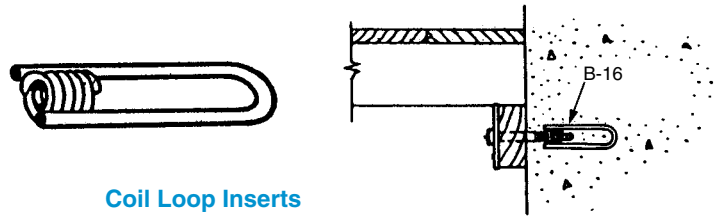

Coil Loop Inserts

## F-56, F-57, F-58, F-59, F-60, F-61 Expanded Coil Inserts

Dayton Superior's Expanded Coil Inserts are coil or closed ferrule structural connection inserts available in two, four or six strut versions, in 1/2" through 1-1/2" diameters, with or without nailing washer.

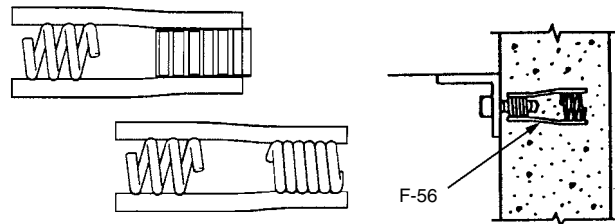

Expanded Coil Inserts

## F-42 Loop Ferrule Insert

Dayton Superior's F-42 Loop Ferrule Insert is a versatile insert suited for structural connections and suspension of equipment, ceilings, piping, etc. Available in 1/4" to 1" diameter closed ferrules in 1/8" increments.

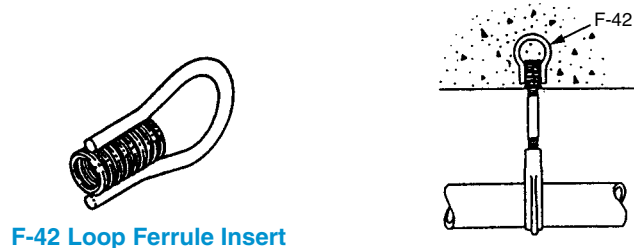

F-42 Loop Ferrule Insert

## F-44 Thin Slab Ferrule Insert

Dayton Superior's F-44 Thin Slab Ferrule Insert is used where the depth of embedment is limited. The F-44 is specially designed to develop good working loads in very thin concrete slabs. Available in 1/4" through 1" diameter, in 1/8" increments, closed ferrules.

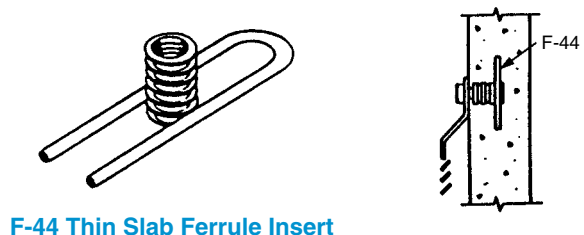

F-44 Thin Slab Ferrule Insert

## F-7, F-7-L, F-8 Shelf Angle Insert

Dayton Superior's Shelf Angle Insert is a malleable iron casting with a wedge shaped holding face that works in conjunction with a special Askew Head bolt. Available in standard and long configurations.

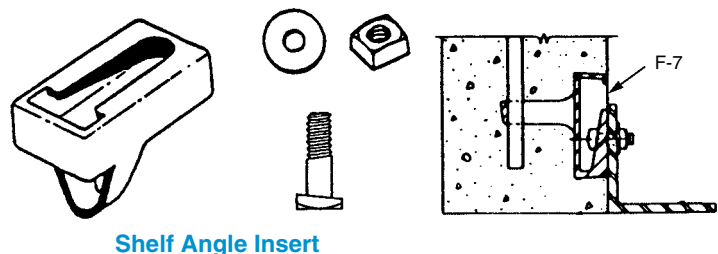

Shelf Angle Insert

## F-54 Ductile Embed

Dayton Superior's F-54 Ductile Embed is a structural embed available in 5/8" through 1-1/4" diameters and is available in several configurations. This is an integrally forged embed with no welds. It is designed to develop pullout and shear loads exceeding A-325 bolt capacities.

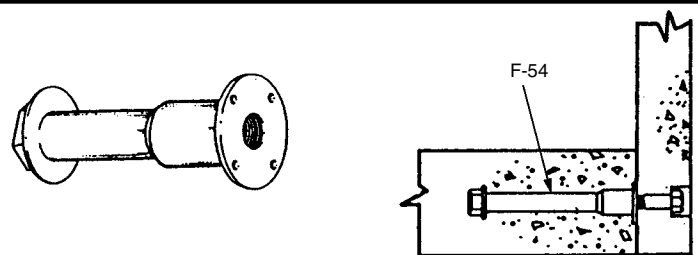

F-54 Ductile Embed

## D-12-A Pencil Rod

Dayton Superior's D-12-A Pencil Rod is available in .225" and .375" mild steel smooth rod for use with the rod clamps shown below. Pencil rod is available in rolls or straightened and cut to length.

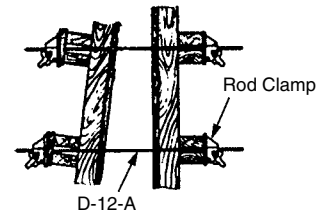
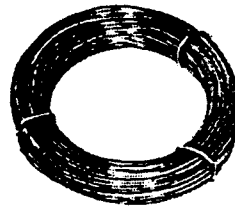

D-12-A Pencil Rod

## D-12 Rod Clamps

Dayton Superior's D-12 Rod Clamps are available for use with .225" through .500" smooth or deformed rod to tie various types of concrete forms. Rod clamps are especially useful on battered and curved wall applications.

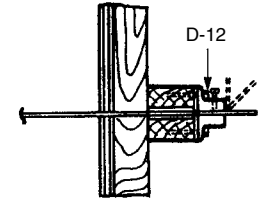
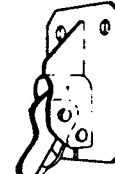
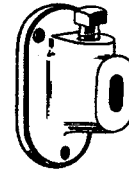

D-12 Rod Clamps

## B-27 and D-6 Nut Washers

Dayton Superior's B-27 and D-6 Nut Washers are one-piece ductile steel designs combining the washer and nut in a single unit. Nail Holes are provided to secure the washer to the formwork. B-27 Nut Washers are furnished with coil thread in 1/2" through 1" diameters for use with any coil thread device. The D-6 Nut Washer has 3/4" Acme thread and is used with the D-2 She-Bolt.

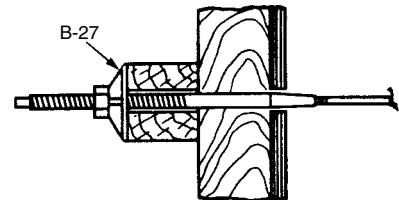
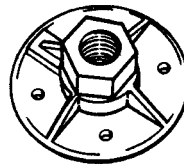

B-27 Nut Washer

## A-95 Dayton Bar

Dayton Superior's A-95 Dayton Bar is a heavy duty pry bar ideally suited for use by tilt-up erectors to strip forms and to "jockey" a panel into position. The Dayton Bar is available in 3" and 5" blade widths.

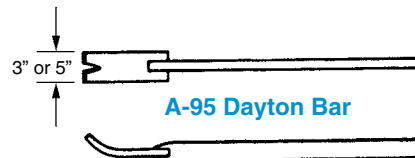

A-95 Dayton Bar

## A-100 SpeedStep Bracket

The Dayton Superior A-100 SpeedStep Bracket is a reusable bracket designed to simplify layout, set-up and stripping of concrete stair forming. One size fits all standard stairs.

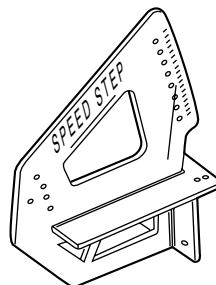

A-100 SpeedStep Bracket

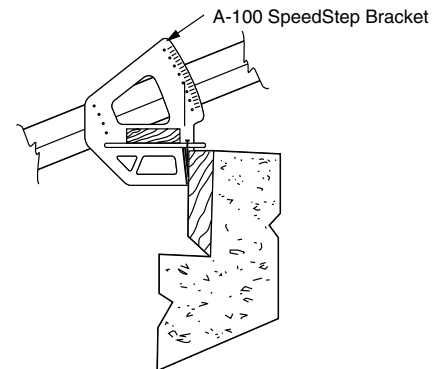

## C-60 Pres-Steel Hanger, Type 1

Dayton Superior's C-60 Pres-Steel Hanger, Type 1 permits installation and adjustment from above the deck. C-60 Pres-Steel Hanger, Type 1 has a nominal 3/8" setback and is used to support deck formwork on interior bridge beams.

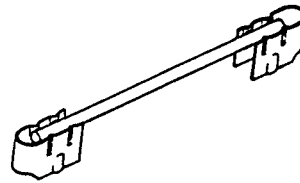

C-60 Pres-Steel Hanger, Type 1

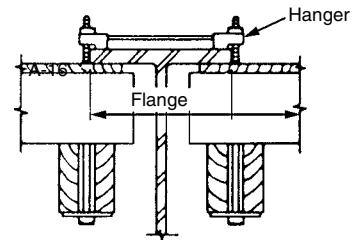

## C-60 Pres-Steel Hangers, Type 2 & Type 7

Dayton Superior's C-60 Pres-Steel Hangers, Type 2 and Type 7 are similar to Type 1 hanger, above, except Type 2 and Type 7 hangers provide for 1" to 2-3/4" haunch conditions, respectively.

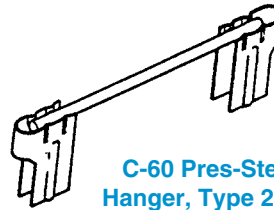

C-60 Pres-Steel Hanger, Type 2 & 7

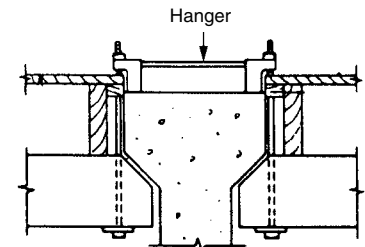

## C-60 Pres-Steel Hangers, Type 4

Dayton Superior's C-60 Pres-Steel Hangers, Type 4 are used on steel interior bridge beams to support deck formwork. The hanger's end sections extend over the edge of the beam to resist shifting.

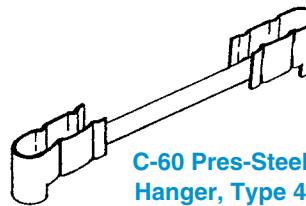

C-60 Pres-Steel Hanger, Type 4

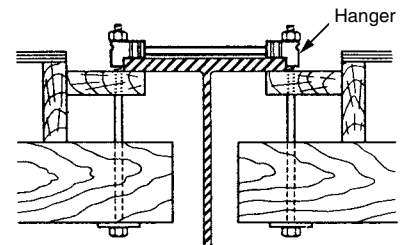

## C-24 Pres-Steel Half Hangers

Dayton Superior's C-24 Pres-Steel Half Hangers are designed to be field welded to a steel bridge beam or to bridge beam rebar stirrups and provide one-sided forming support.

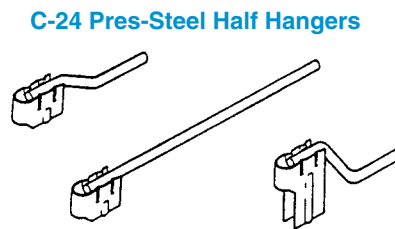

C-24 Pres-Steel Half Hangers

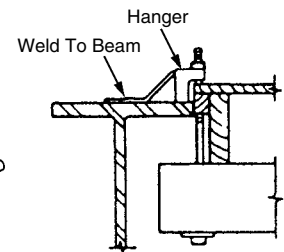

## C-25 Adjustable Half Hanger

Dayton Superior's C-25 Adjustable Half Hanger attaches to a bridge beam stirrup and is designed to support one-sided forming on applications where welding is not an option.



C-25 Adjustable Half Hanger

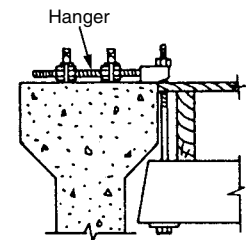

## C-41 Coil Rod Hanger

Dayton Superior's C-41 Coil Rod Hanger is designed to support interior forming on both sides of a bridge beam and to breakback inside the concrete. The C-41 Coil Rod Hanger can be used effectively with any haunch height condition.

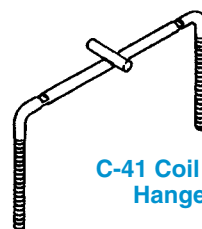

C-41 Coil Rod Hanger

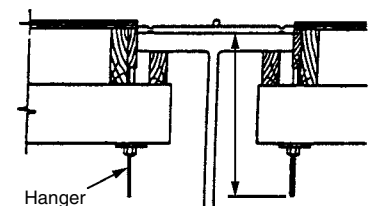

## C-60 Pres-Steel Hanger, Type 1-A

Dayton Superior's C-60 Pres-Steel Hanger, Type 1-A is designed with a 45° end section at one end and is used to support fascia overhang formwork.

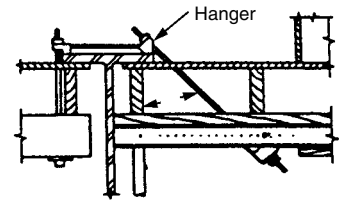
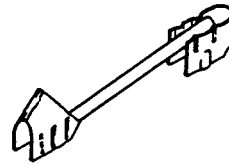

C-60 Pres-Steel Hanger, Type 1-A

## C-62 45° Pres-Steel Hanger

Dayton Superior's C-62 Pres-Steel Hanger is designed with a 45° end section at one end and is used to support fascia overhang formwork. Haunch heights up to 2-3/4" can be accommodated.

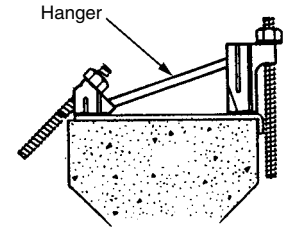
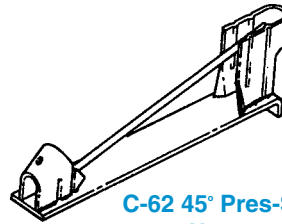

C-62 45° Pres-Steel Hanger

## C-60 45° Pres-Steel Hangers, Type 4-A & Type 5-A

Dayton Superior's C-60 Pres-Steel Hangers, Type 4-A and Type 5-A are designed with a 45° end section at one end to support fascia overhang formwork. The 90° end section extends over the edge of the bridge beam for added support and resistance to shifting.

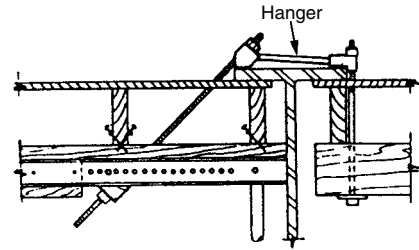
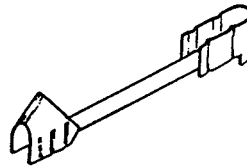

C-60 45° Pres-Steel Hanger, Type 4-A

## C-24 45° Pres-Steel Half Hanger

Dayton Superior's C-24 45° Pres-Steel Half Hanger is designed to be field welded to a steel beam or to concrete beam rebar stirrups to provide one-sided forming support.

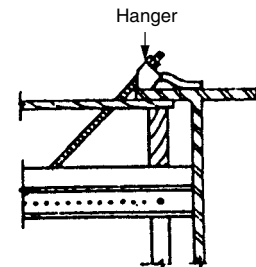
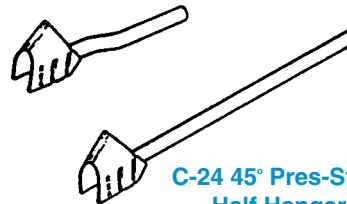

C-24 45° Pres-Steel Half Hanger

## C-25 45° Adjustable Half Hanger, Type 1-A

Dayton Superior's C-25 45° Adjustable Half Hanger, Type 1-A attaches to a bridge beam rebar stirrup to support one-sided forming applications where welding is not an option.

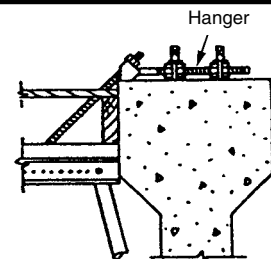

C-25 45° Adjustable Half Hanger, Type 1-A

## C-41 45° Coil Rod Hanger, Type 1-A

Dayton Superior's C-41 45° Coil Rod Hanger, Type 1-A is designed to support interior forming on one side of a bridge beam and fascia forming on the other. The C-41 45° Coil Rod Hanger, Type 1-A can be used effectively with any haunch height condition and can be broken back inside the concrete.

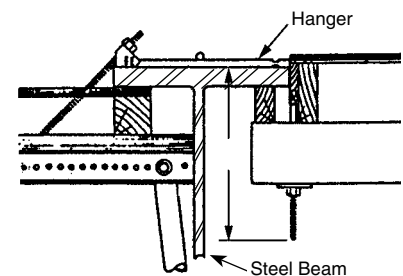
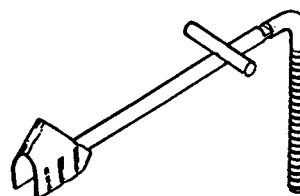

C-41 45° Coil Rod Hanger, Type 1-A

## C-65 Adjustable Joist Hanger

Dayton Superior's C-65 Adjustable Joist Hanger is available in two sizes that accept 2X and 4X joist material. The Adjustable Joist Hanger can be used on concrete beams, steel girders and box culverts. It is adjustable and completely reusable.

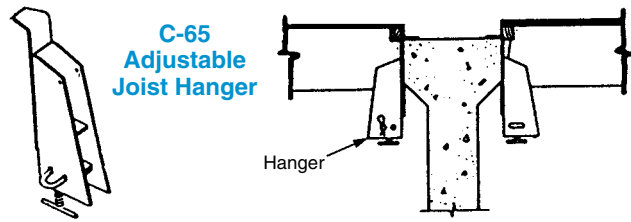

## C-49 Bridge Overhang Bracket

Dayton Superior's C-49 Bridge Overhang Bracket supports bridge deck fascia formwork. It can be mounted to steel or concrete girders using an appropriate hanging device.

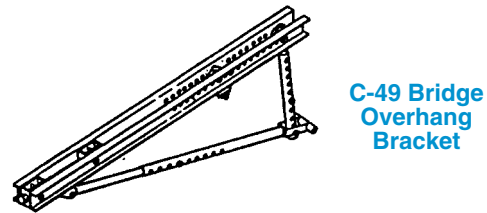

## C-49-D Bridge Overhang Bracket For Deep Girders

Dayton Superior's C-49-D Bridge Overhang Bracket for deep girders supports bridge deck fascia formwork. It has been designed to mount to deep steel or concrete girders, using an appropriate hanging device.

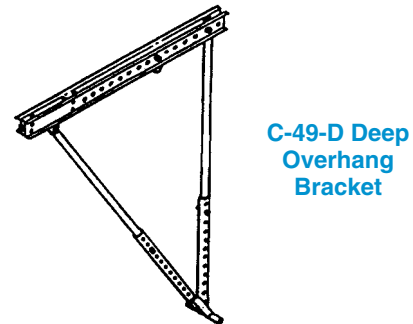

## C-49-W Bridge Overhang Bracket

Dayton Superior's C-49-W Bracket aids in preventing web of beam from bending during construction of bridge deck. Constructed with all-steel support frame to improve stability and resist movement. Meets ANSI Specification A 10.9, Sections 6.5.1, 6.6.1, 7.2.1 and ACI 347 Specification 2.4 Screw Jacks extend up to 6"

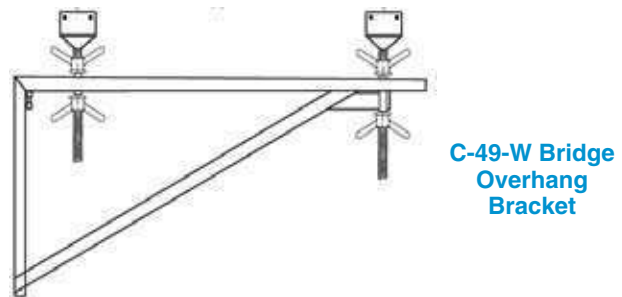

## C-89 Heavy Duty Bridge Overhang Bracket

Dayton Superior's C-89 Heavy Duty Bridge Overhang Bracket supports bridge deck fascia formwork. The bracket, available in 72" or 90" versions, can be utilized on steel or concrete girders using the appropriate 3/4" hanging device.

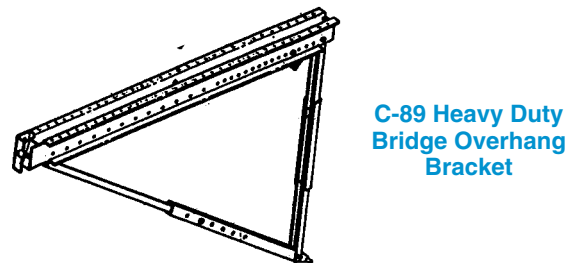

## D-101-A Through D-104-A DB-SAE Splicer

Dayton Superior's D-101-A through D-104-A DB-SAE Splicers are one-piece forged units made from grade 60 rebar and are supplied with NC or UNC threads depending on size. Splicers are available in bar sizes #4 through #11 in straight, hooked, double-ended and bolt-headed configurations.

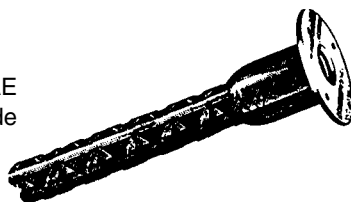

DB-SAE Splicer

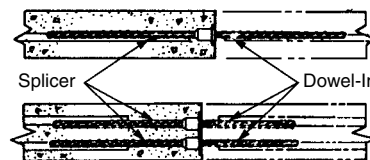

## D-101 Through D-104 Dowel-In

Dayton Superior's D-101 through D-104 Dowel-Ins are manufactured from grade 60 rebar material and are available in sizes #4 through #11 for use with the DB-SAE Splicer shown above. Dowel-Ins are available in straight, 90° hooked, 180° hooked and double-ended configurations.



Dowel-In

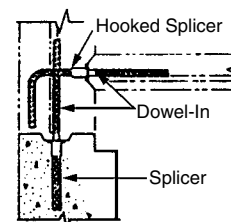

## D-110 US/MC-SAE Couplers

Dayton Superior's US/MC-SAE Coupler is suitable for joining rebar end to end. Available in sizes #4 through #18, the coupler is a convenient alternative to lap splicing or butt welding. Transition Coupler for joining different size rebar is also available.

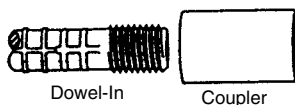

US/MC-SAE Coupler

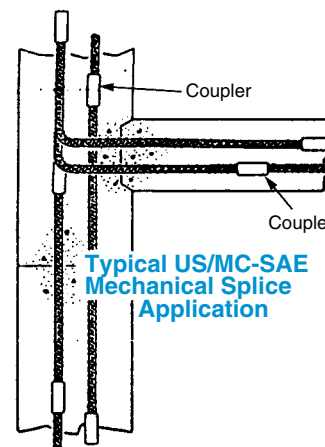

## D-140 Dayton Shear Resistance (DSR) System

Dayton Shear Resistance (DSR) System is a cost effective solution to punching shear at column/slab connections. The Shear Resistance System is fabricated with special studs, either studwelded or mechanically crimped to a steel rail. The system features large, specially designed headed studs studwelded to a steel base rail. The heads are ten times the cross-sectional area of the stud's stem to provide superior anchorage and prevent slippage. The base plate ensures proper spacing and provides bottom anchorage.

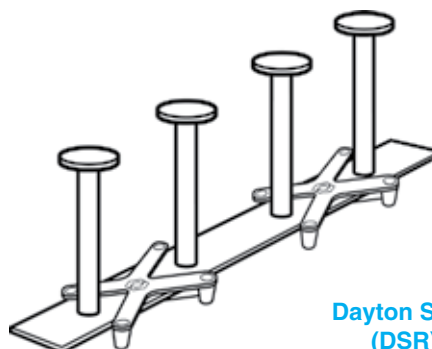

D-140 Dayton Shear Resistance (DSR) System Rail

## D-158 End Anchors

Dayton Superior's D-158 End Anchors are available in all rebar sizes and in various configurations to aid in situations where rebar congestion or other difficult concreting conditions restrict placement of hooked rebar or long lap splices.

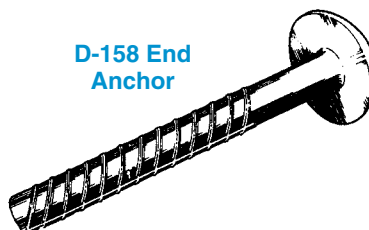

D-158 End Anchor

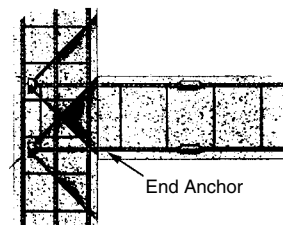

## D-250 Bar-Lock Couplers

Dayton Superior's D-250 Bar-Lock Couplers provide a simple, quick, cost effective method for splicing rebar in tension and/or compression. Bar-Lock Couplers are available for use with smooth or deformed bars in sizes #4 through #18.

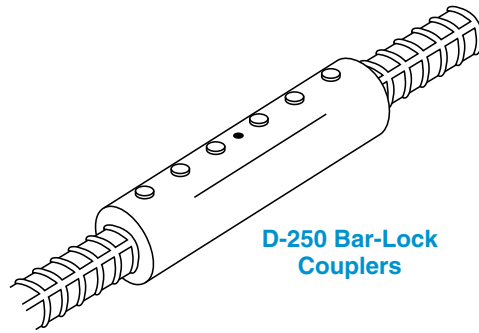

## Taper Lock

Dayton Superior is proud to offer the portable, high-speed taper cut solution! Turn the system that's already been proven on sites throughout Europe into your on-site advantage. Dayton Superior is the only company able to bring the reliable Taper-Lock design to North American fabricators and contractors.

Taper Lock's portable design allows you to take the system wherever you need it. Sharpen cutters up to three times for previously unheard of efficiency! Spend less money on new blades and save your crew from unnecessary downtime. It's revolutionary high-speed taper cut more than doubles the production of conventional cutters, allowing you to beat deadlines. The system uses conventional water-soluble cutting fluid. The strong unit withstands tough projects. Its straightforward process makes operation and repair easy.



## Slab Bolster

Dayton Superior's Slab Bolster is used to support lower slab steel from the slab form. Legs are spaced on 5" centers. Available in 3/4" to 3" heights in 5' lengths and in bright basic, galvanized, plastic protected, epoxy coated or stainless steel protected.

Slab Bolster

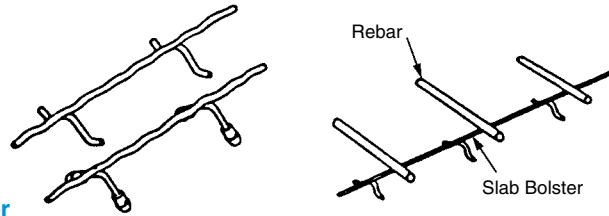

## Beam Bolster

Dayton Superior's Beam Bolster is used to support lower beam steel from the soffit form. Legs are spaced on 2-1/2" centers. Available in 1-1/2" to 5" heights in 5' lengths. Manufactured in bright basic, plastic protected, epoxy coated, galvanized or stainless steel protected.

Beam Bolster

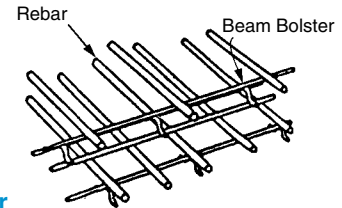

## Continuous High Chair

Dayton Superior's Continuous High Chair provides support for upper slab steel eliminating the need for carrier bars. Fabricated in 2" to 15" heights in 5' lengths with legs spaced on 7-1/2" centers. Available in bright basic, plastic protected, epoxy coated, galvanized and stainless steel protected.

Continuous High Chair

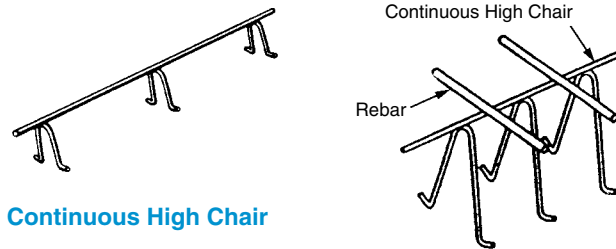

## Individual High Chair

Dayton Superior's Individual High Chair is used to support upper steel directly or by means of a carrier bar. Available in 2" to 15" heights in bright basic, plastic protected, epoxy coated, galvanized and stainless steel protected.

Individual High Chair

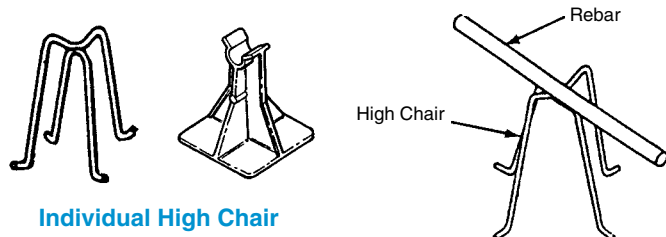

## Bar Chair

Dayton Superior's Bar Chair is used to support wide spaced light steel in slab construction. Available in 3/4" to 2" heights in bright basic, plastic protected, epoxy coated, galvanized and stainless steel protected.

Bar Chair

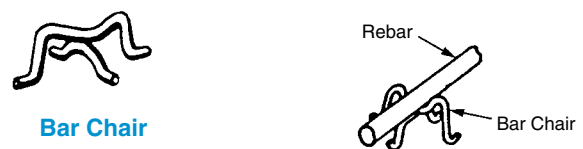

## Joist Chair

Dayton Superior's Joist Chair is used to support two bottom bars in the ribs of joist or grid type slabs. Available in 4", 5" and 6" overall widths; 3/4", 1" and 1-1/2" heights; and in bright basic, plastic protected, epoxy coated, galvanized and stainless steel protected.

Joist Chair

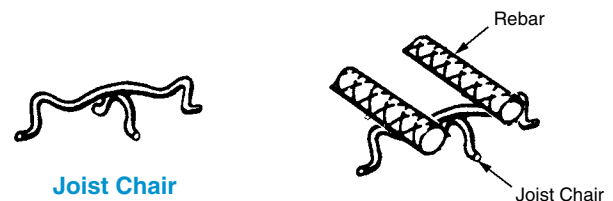

## Aztec™ E-Z Chair - PEZ \*

The Aztec E-Z Chair is the most popular on the market. It features Standard “Concrete Gray” color (custom colors available-inquire), minimal surface contact and is designed for maximum aggregate flow and concrete consolidation. It provides high load capacity, fits up to #8 rebar, but does not straddle the bottom rebar mat in double mat applications (for straddle applications, see Aztec Tower Chair). Applications: Single Mat -Rebar or Wire Mesh, Bottom Layer Double Mat Rebar or Wire Mesh, Tilt-Wall, Side-Form Spacer, On-Grade: when used with Sand Plate Cover Height: From 3/4” to 6” (1/4” increments)

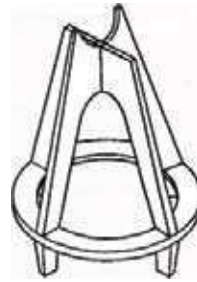

E-Z Chair (PEZ)

## Aztec Tower Chair - PTC / Bar Chair - PBC \*

The Aztec Tower Chair and Bar Chair both feature Standard “Concrete Gray” color, offer minimal surface contact, and are designed for maximum aggregate flow and concrete consolidation. Both fit up to #8 rebar and the Tower Chair straddles the upper rebar mat in double mat applications. Applications: Single Mat -Rebar or Wire Mesh, Bottom Layer Double Mat-Rebar or Wire Mesh, Tilt-Wall, Side-Form Spacer, On-Grade: when used with Sand Plate. Cover Height: From 3/4” to 10” (1/4” increments)

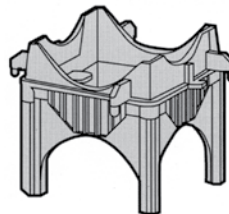

Bar Chair (PBC)

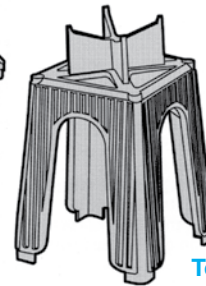

Tower Chair (PTC)

## Aztec Straddle Chair - PSC \*

The Aztec Straddle Chair offers a minimal footprint with a staple down option and straddles lower rebar mat. It accommodates #3 to #11 rebar with 2 sizes per chair. The straddle Chair has the same material characteristics as Aztec Tower Chair. Applications: Single Mat -Rebar or Wire Mesh, Bottom Layer Double Mat-Rebar or Wire Mesh, Tilt-Wall, Side-Form Spacer, On-Grade: when used with Sand Plate Cover Height: From 3” to 7-3/4”

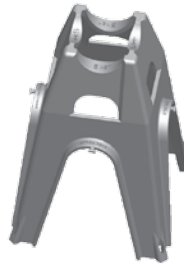

Straddle Chair (PSC)

## Aztec Castle Chair - PCC \*

The Aztec Castle Chair is the most stable on-grade chair available. It features a heavy-duty, smooth bottom, stackable design, ideal for use on insulating foam or vapor barriers. It fits up to #8 rebar and supports 500 lbs. + loads. Each chair comes in two height combinations reducing inventory. Application: On-Grade, Single Mat - Rebar or Wire Mesh, Bottom Layer Double Mat-Rebar or Wire Mesh, Precast/Tilt-Wall, Insulated “Sandwich” Panels. Cover Height: From 1-1/2” to 6-1/4” (1/4” increments)



Castle Chair (PCC)

\* Meets all requirements and qualifies as a CRSI Class 1 Bar Support.

## Aztec™ StrongBack Slab / Beam Bolster - PSBB \*

The Aztec StrongBack Slab / Beam Bolster is high load strength & impact resistant, it qualifies for use as a Beam Bolster with 2-1/2" leg spacing, and can be used individually or locked together to create any length. The Strongback Slab is manufactured in 30" lengths in standard boxes. Special packaging available in 5' or 10' sections, bundled and palletized. Application: Elevated Slab, TiltWall, Precast, Post-Tension, Parking Garage Decks, Side-Form Spacer. Cover Height: From 3/4" to 3" (1/4" Increments) Meets all requirements and qualifies as a CRSI Class 1 Bar Support.



StrongBack Slab Beam Bolster -PSBB

## Aztec StrongBack SBU Slab Bolster Upper - PSBU \*

The Aztec StrongBack Slab Bolster Upper is designed for use with Epoxy-Coated/FRP/Stainless Steel/Galvanized rebar and is intended for use in corrosive environments, it is as strong as metal SBU. The Strong Back Slab Bolster Upper spans corrugations in elevated deck applications, is suitable for use on Vapor Barriers or Insulating Foam, no overlap required, manufactured in 30" lengths in standard boxes. special packaging available in 5' or 10' sections, bundled and palletized. Application: Supports top layer in Double Mat application, Rebar or Wire Mesh, Slabs, Heavy Duty On-Grade, Corrugated Decking, Side-Form Spacer-below-grade applications only, Precast. Cover Height: From 1" to 3-1/4" (1/4" increments)

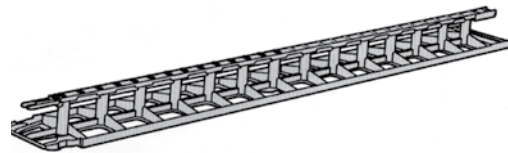

StrongBack SBU Slab Bolster Upper -PSUB

## Dowel Baskets

Dayton Superior's Dowel Baskets are used for expansion and contraction joints in 6" to 9" concrete slabs. Dowel Baskets and their accessories are available in several styles to meet individual project specifications.

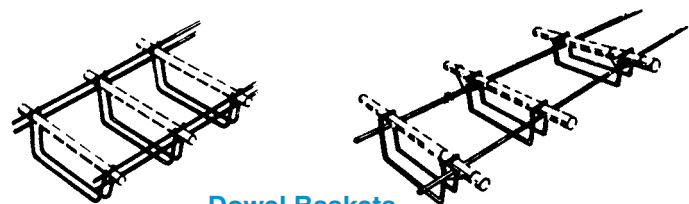

Dowel Baskets

\* Meets all requirements and qualifies as a CRSI Class 1 Bar Support.

## T-41 Ground Release Lifting Insert

Dayton Superior's T-41 Ground Release Lifting Insert is a 4 ton insert designed to accommodate the T-43-R Lifting Hardware shown below. The insert is complete with plastic void and wire or plastic protected base.

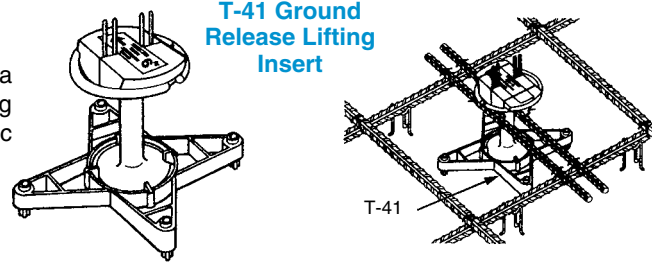

## T-43-L Ground Release Lifting Hardware

Dayton Superior's T-43-L Ground Release Lifting Hardware is designed to lift and place tilt-up wall panels quickly and efficiently. The unit offers high safe working loads, ease of operation and a positive ground release.

T-43-L Ground Release Lifting Hardware

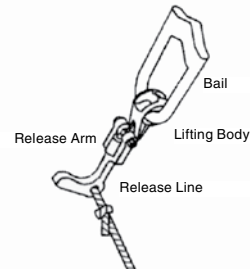

## T-49 Gyro Tilt Plus® Insert

Dayton Superior's T-49 Gyro Tilt Plus Insert is a 4 ton insert designed to accommodate the T-50 Gyro Tilt Plus Hardware shown below. The insert is complete with plastic void and plastic protected wire base.

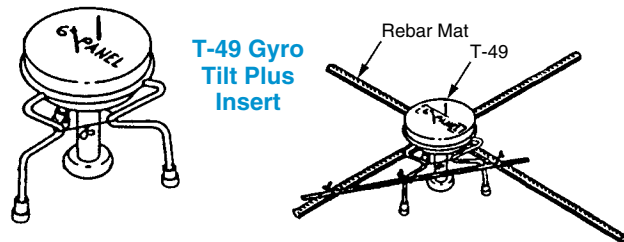

T-49 Gyro Tilt Plus Insert

## T-50 Gyro Tilt Plus® Hardware

Dayton Superior's T-50 Gyro Tilt Plus Hardware is designed to lift and place tilt-up wall panels quickly and efficiently. The system is easy to use, quick and has a positive ground release.



T-50 Gyro Tilt Plus Hardware

## T-90-F Tilt-Up 3 Face Lift Insert

The Dayton Superior T-90-F Tilt-Up 3 Face Lift Insert is furnished as a complete assembly. It is easy to position, easy to tie into the rebar mat and quickly attached to the T-92 Lifting Hardware, shown below.

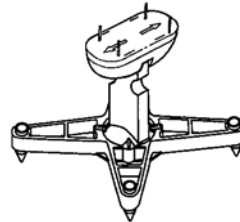

T-90-F Face Lift Insert Assembly

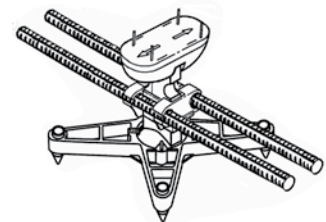

T-90-F Face Lift Insert  
(Shown with optional T-90-C Floating Rebar Clip)

## T-92 Tilt-Up 3 Lifting Hardware

The Dayton Superior T-92 Tilt-Up 3 Lifting Hardware is designed for use with face lift and edge lift applications and will readily align itself with the pull of the rigging. Ground release is easily accomplished once the load has been relaxed.

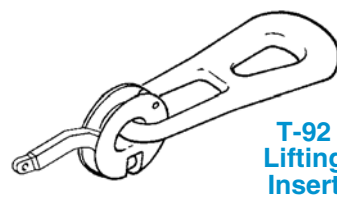

T-92 Lifting Insert

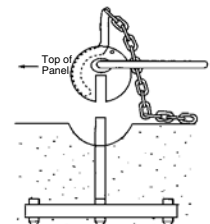

## T-110 Superior Lift System

The Dayton Superior T-110 Superior Lift Insert consists of a forged foot anchor, 4-leg wire base and plastic void former. The insert is positioned with the void direction toward the top of the panel and then is tied in place to the rebar cage. The T-120 Superior Lifting Hardware allows quick attachment to the insert and remote ground release after panel has been erected and braced. The T-110 Superior Lift Inserts are shipped assembled, ready to go and are sized 1/8" less than the panel thickness.

T-110 Superior Lift System



## T-120 Superior Lift Hardware

The Dayton Superior T-120 Superior Lift Hardware is designed to easily attach to the insert by engaging the curved clutch handle into the opening in the anchor. The ball of the hardware is designed to readily align itself to the pull of the rigging. Once engaged and under load, it can not be disengaged by remote ground release until the load has been removed in lowering the rigging. The T-120 is used for both face and edge lift system conditions.

T-120 Superior Lift Hardware

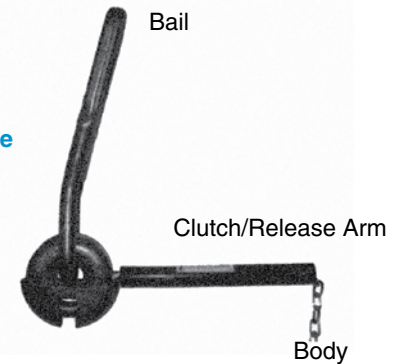

## Wall Braces

Dayton Superior's Wall Braces are all steel, heavy duty wall braces designed to quickly and easily align and brace tilt-up wall panels. Wall braces are available in several models that span brace lengths of 7'-6" to 52'-0" with a load rating of 6,500 to 9,000 lb. SWL.

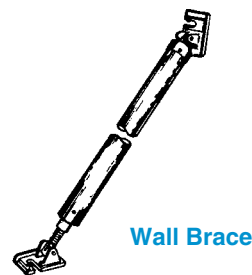

Wall Brace

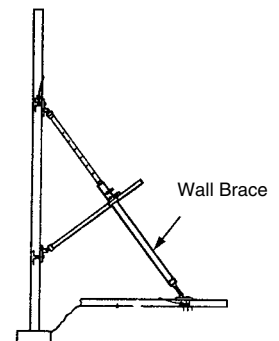

## Brace Inserts

Dayton Superior's Brace Inserts are available in several versions. They are designed to be cast-in-place in the concrete panel and used to anchor tilt-up wall braces during the construction sequence.

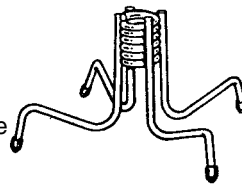

Wall Brace Inserts

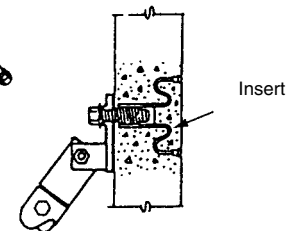

## T-13 Coil Anchor

Dayton Superior's T-13 Coil Anchor is a drill-in anchor designed for use in the floor slabs of tilt-up buildings to attach and anchor wall braces during panel erection or to secure emergency lift plates.

T-13 Coil Anchor

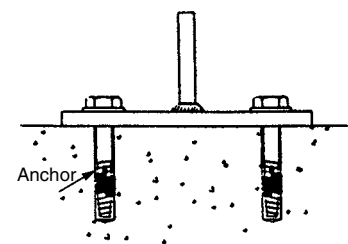

## T-13-D Strongback Anchor Bolt

The T-13-D Strongback Anchor Bolt is designed to be used to attach strongbacks to a panel. The T-13-D allows the contractor to locate a strongback on a panel after the panel has been poured. This is accomplished by using the same procedure as the T-13 Bolt, drilling a 3/4" diameter hole in the panel and installing the Strongback Anchor Bolt by torque to a minimum of 200 ft. lbs. 3/4" B-12 Coil Rod or 3/4" B14-A Adjustable Coil Bolts, with B-11 Plate Washers then are screwed into the top of the Strongback Anchor Bolt and the strongbacks are attached to the panel. Once the panel is erected and the strongbacks are removed, the T-13-D Strongback Anchor Bolt is removed and reused on future panels. The bolt is available in both a 4-1/2" length and a 6" length.

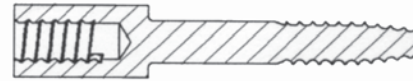

T-13 Strongback Anchor Bolt

## T-12 and T-26 Swivel Lift Plates

Dayton Superior's T-12 and T-26 Swivel Lift Plates are designed for use with 3/4" through 1-1/2" lifting bolts to attach to coil lift inserts cast in a tilt-up wall panel.

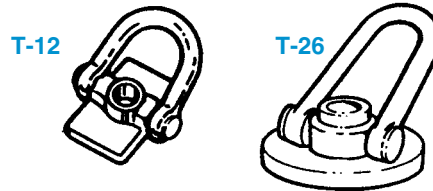

T-12

T-26

## T-8 Lifting Angle, T-27 Edge Lifting Plate

Dayton Superior's T-8 Lifting Angle and T-27 Edge Lifting Plate are designed for use with 3/4" or 1" tandem lifting inserts to lift and position tilt-up panels.

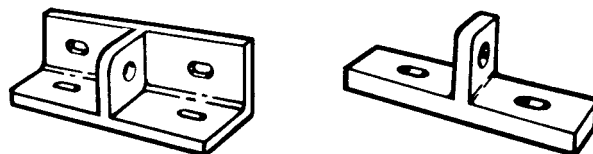

T-8 Lifting Angle

T-27 Edge Lifting Plate

## T-61-R and T-62-R Quick Release Strongback System

Dayton Superior's T-61-R and T-62-R Quick Release Strongback System, including insert, hardware and aluminum strongbacks, is designed to quickly attach and release tilt-up wall panel strongbacks to speed up the setting sequence.

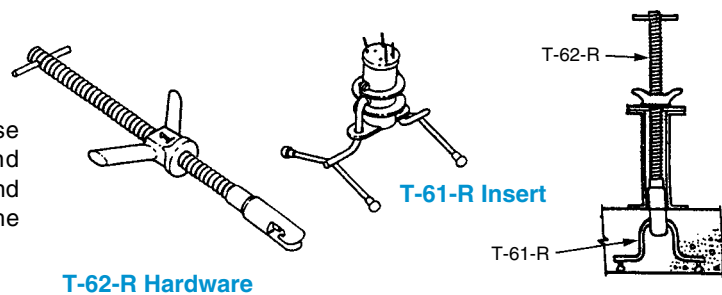

T-62-R Hardware

T-61-R Insert

T-61-R

T-62-R

## P-50 Swift Lift® Universal Lifting Eye P-51 Swift Lift® Lifting Eye

Swift Lift lifting eyes are used with the Swift Lift anchors shown below to strip, transport and erect precast concrete elements. The P-50 units are available in 1, 2, 4, 8 and 20-ton safe working load capacities. The P-51 units are available in 2T, 4T and 8T units only.

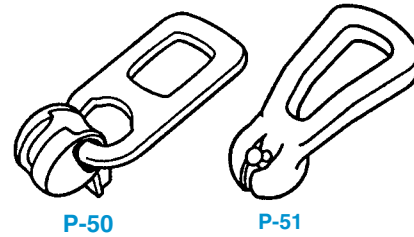

## P-52 Swift Lift® Anchors P-53 Swift Lift® Eye Anchors

Swift Lift anchors may be used with either of the above Swift Lift lifting eyes. Swift Lift anchors are available in various lengths and capacities to meet the requirements and needs of the precast industry.

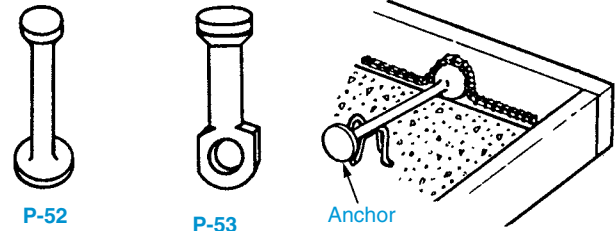

## P-56-PL Swift Lift® Recess Plugs P-69-M Swift Lift® Magnetic Setting Plate

Use Swift Lift Recess Plugs to securely hold Swift Lift anchors in place during placement of the concrete. The plugs also form a void around the anchor's head, which allows for easy attachment of the lifting hardware.

The P-69-M Magnetic Setting Plate offers the precaster a fast and secure method of attaching Swift Lift anchors to the side or bottom of steel forms.

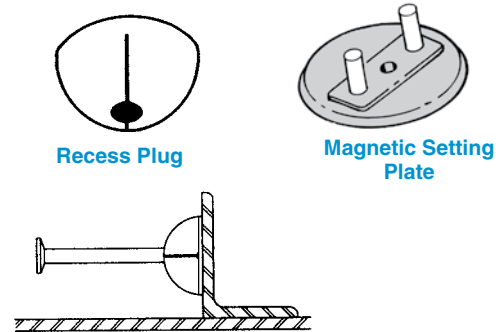

## P-91-S and P-91-NC Fleet-Lift™ Hardware

Dayton Superior's Fleet-Lift Hardware is used with Fleet-Lift Anchors to face-lift or edge-lift precast concrete elements. Units are designed to connect and disconnect quickly and to rotate for easy alignment.

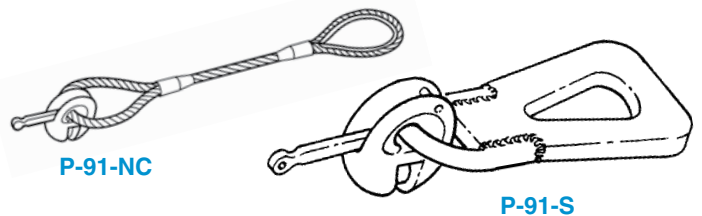

## P-92 to P-97 Fleet-Lift™ Anchors

Fleet-Lift anchors are available in 1, 2, 4, 6 and 8-ton capacities and are used with the above hardware to strip, transport and erect precast concrete elements.

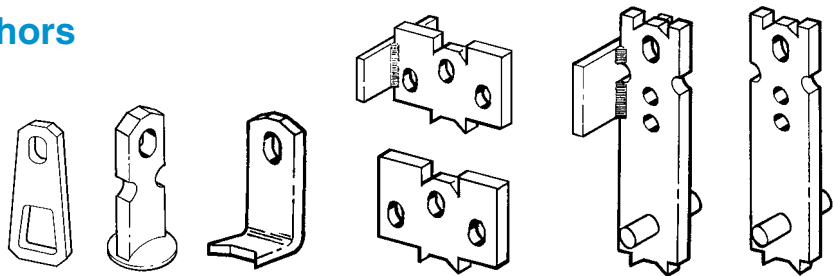

## P-92-F Fleet-Lift™ Forged Erection Anchor

The Fleet-Lift Forged Erection Anchor is specifically designed to provide greater lifting capacities for horizontal to vertical edge lifts. These anchors are available in 3T, 6T and 10T SWL's. The anchors are forged to provide 20% greater safe working loads. This anchor utilizes the Fleet-Lift lifting hardware and the P-99 Recess Plugs. Available in plain or hot-dipped galvanized finishes.

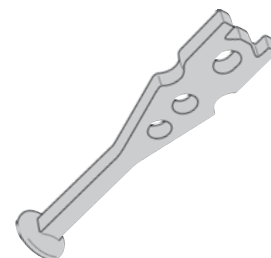

## P-99 Fleet-Lift™ Recess Plugs P-100-M Fleet-Lift™ Magnetic Plate

Fleet-Lift Recess Plugs are designed to hold Fleet-Lift anchors securely in place during the placement of the concrete. They also form a void around the anchor's head, which allows for easy attachment of the lifting hardware.

A fast and secure method of attaching Fleet-Lift anchors to steel forms is available with the P-100-M Magnetic Plate.

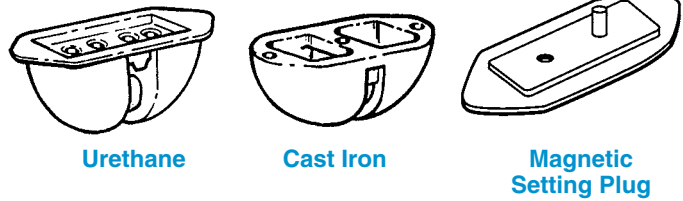

## P-75 Utility Anchor P-75-H Utility Anchor Heavy P-76 Utility Anchor Setting Plugs

The Dayton Superior Utility Anchors are designed to economically simplify the stripping, transporting and installation of underground or other types of utility precast concrete elements. As special lifting hardware is not required for use with these utility anchors, they offer not only economical advantages, but versatility and ease of use.

The P-75 units are available in several safe working load capacities, up to 10,000 lbs SWL in tension. The P-75-H anchor has a safe working load of 24,000 lbs in tension.

Reusable setting plugs, used with either 3/8" coil threaded rods or setting plates, are available to set anchors in place in the forms.

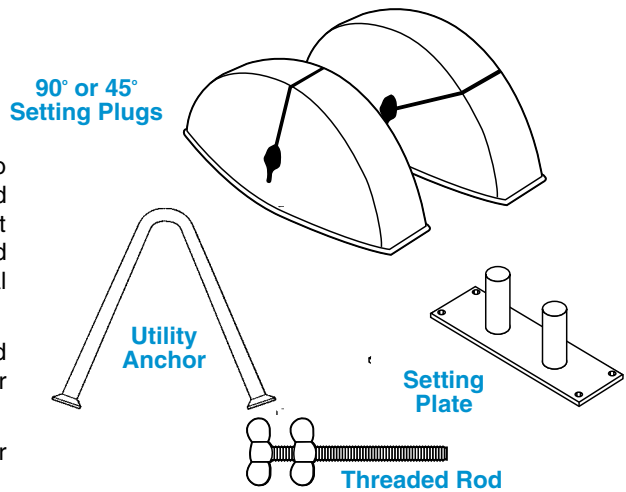

## P-77 Double Tee Anchor

The Dayton Superior P-77 Double Tee Anchor is specifically designed to provide greater lifting capabilities for Double Tees and other concrete products. This Anchor has the capacity of 15,000 lbs. SWL. The anchors are designed to utilize standard Crosby Hooks for lifting of the Precast Product, requiring no special hardware be purchased by the precaster or erector. The head of the anchor is 1/2" below the concrete surface to prevent rusting and to eliminate any removal of steel, a common practice when using "strand" as an anchor. The recess member (P-75-D) utilized to form the void is designed to allow up to a 30% angle on the sling to prevent spalling of the concrete from the contact with the Crosby Hook. A smaller void is also available if sling angle and hook size are reduced. See P-76-D 4T and 7.5T Disposable Void Former.

P-77 Double Tee Anchors are available in 3 common lengths of 9-1/2", 15-1/2" and 23-1/2". All are stocked in plain finish and available in Hot-dipped galvanized finish.

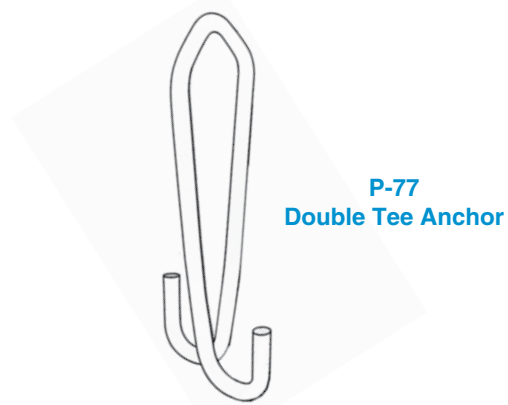

## P-76-D 7.5 T Disposable Void Former

The Dayton Superior P-76-D 7.5 T Disposable Void Former was created to allow a large enough void for the P-77 Double T Anchor to utilize Crosby Hooks For Lifting of the double T and other precast products. The 7.5T Disposable Void Former is a 2 part recess plug fabricated from high density polyethylene plastic. The two-piece design snaps together around the head of the anchor to securely grasp the anchor. The tight fit eliminates the concrete entering into the void. The design secures the anchor in proper position and maintains 1/2" clearance between top edge of the anchor and the top surface of the concrete. The tabs on the ends of the void former provide a convenient method to nail the assemble to a form. The Void Former is removed and discarded after usage.

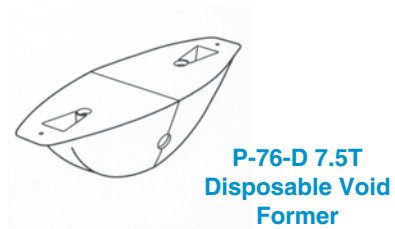

## P-80/P-81 Shimpaks

Dayton Superior's shimming material is an engineered multipolymer plastic which provides an optimum combination of physical properties for a shim in applications where high compressive strength and load bearing is important. It facilitates the placement of architectural members.

Popular sizes are 4" x 6" and 4" x 4" paks which are 1-1/16" thick. Shimpaks are made up of shims in the following thickness sequence; one 1/16th, three 1/4ths and two 1/8ths.

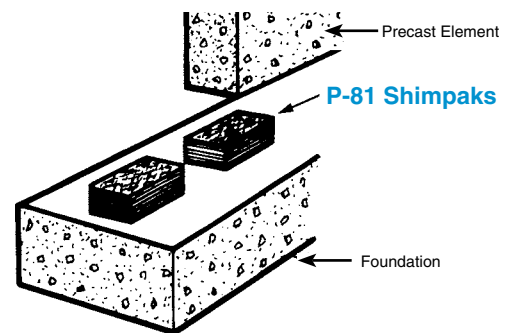

## P-24 Delta Tie Insulated Concrete Panel Tie

Dayton Superior offers a unique composite panel tie for use in connecting the exterior and interior wythes of precast concrete insulated "sandwich" panels. The use of the P-24 Delta Tie offers quick and easy tie installation resulting in stiffer panels, increased load bearing and material, labor and transportation cost savings.

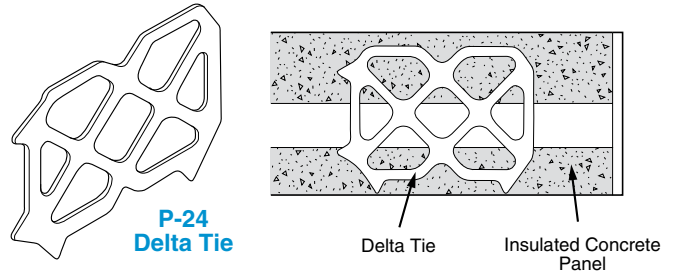

## NC Threaded Connection Inserts

### P-30 Corewall™ Slotted Inserts P-86 Star Inserts

Various types of national course (NC) threaded inserts are available for use in making permanent connections in and between precast concrete elements. These inserts are used with bolts as small as 1/4"-20 NC and as large as 1-1/4"-7 NC.

The P-30 Corewall Slotted Inserts are normally used to make permanent connections between precast concrete panels and the structural frame of a building. They are available for use with 3/4"-10 NC bolts and steel strip anchors.

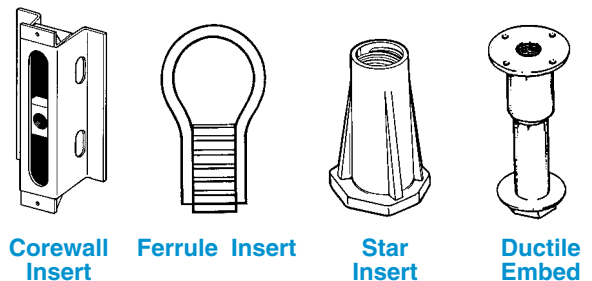

## Formliners and Rustications

Over 120 formliner patterns are available in several different materials and thicknesses, each providing a distinct surface treatment. Dayton Superior's rustications are available in various shapes, materials and sizes to meet the needs of the precaster.

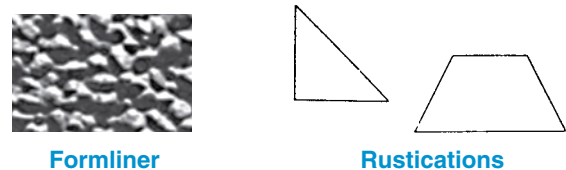

# Prestress Strand Restraining Devices



## Prestress Strand Restraint Devices

Dayton Superior's has a large comprehensive line of prestress strand "hold down" units that have been thoroughly tested and broadly accepted as the Standard of the Precast/Prestressed Concrete Industry. They are fabricated without welds, using only positive mechanical connections between the various components of each device.

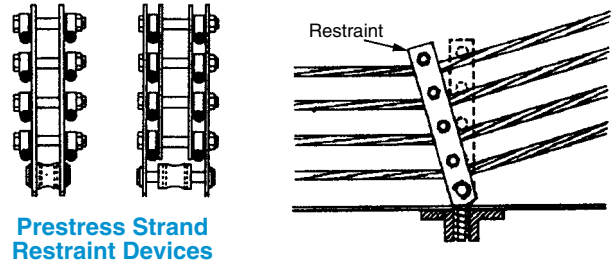

Prestress Strand Restraint Devices

## H-60-A CCL Spring Loaded Anchors H-60-B CCL Open Chucks

The Spring Loaded and Open Chucks are used in prestressing operations. They are available in wire and strand form 1/4" to 0.6"

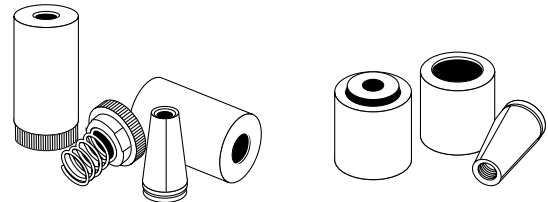

H-60-A CCL Spring Loaded Anchors

H-60-B CCL Open Chucks

## H-64 CCL Stressomatic Prestressing Jack P-66 CCL Prestressing Pump

The CCL jacks and pumps are extremely durable units that provide accurate and reliable strand prestressing. The jacks feature power lock-off mechanisms and extended service life. Jacks are available in three sizes while the pumps are available in two sizes.

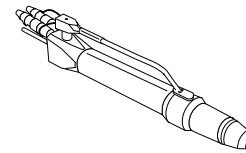

H-64 CCL Stressomatic Prestressing Jack

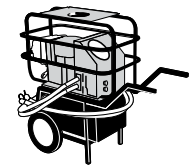

P-66 CCL Prestressing Pump

## P-12 Dur-O-Web Shear™ Reinforcement

Dur-O-Web is a prefabricated structural web reinforcement assembly that replaces conventional stirrups in prestressed tees. It allows the spacing of the smooth, round vertical and horizontal wires to vary, meeting various design requirements.

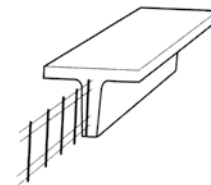

## Steel Forms for Precast

Dayton Superior's offers precasters in various types and sizes of steel forms as may be required. For medium barriers, utility poles, pile forms, girder forms and double tee forms.

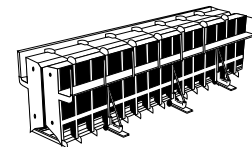

## Magnets

Dayton Superior offers a complete line of integrated magnetic components designed to help save time and money in precast forming applications. The Dayton Superior Magnetic Precast Forming System includes On/Off Magnets, Loaf Magnet, Button Magnets, Chamfer and Reveals, Embedment and Insert Magnets, Manhole Step Magnets and Custom Magnets for any application.

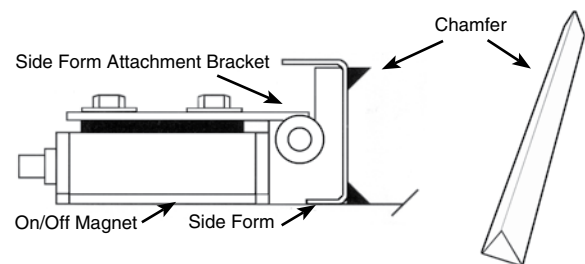

## Standard Screed Bases

Dayton Superior's has a variety of screed bases available to meet the requirements of flat slab work. Adjustable, free-fit, sub-grade, etc., are used with the cradle heads, below, to support the screed rails.

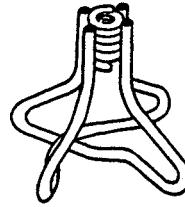

Typical Screed Base

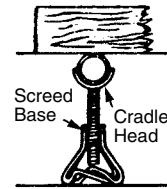

## Fill Type Screed Bases

Dayton Superior's Fill Type Screed Bases are similar to the standard bases described above, but are designed to be pushed into the fill instead of free-standing like the standard bases above.



Fill Type Screed Base

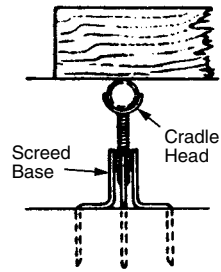

## Cradle Heads

Dayton Superior's Cradle Heads are used in conjunction with the various screed bases to support the screed rails. Various styles and sizes are available to fit the job requirements.

Cradle

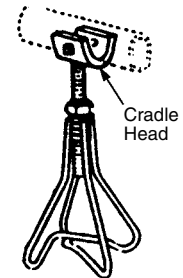
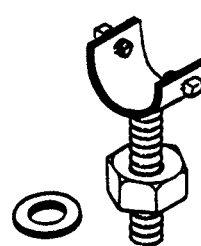
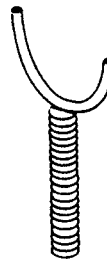

## G-33 Screed Key Joint

Dayton Superior's G-33 Screed Key Joint is an economical replacement for bulkhead slab forms. Available in 10' lengths for 4", 5", 6", 8" and 10" thick slabs.

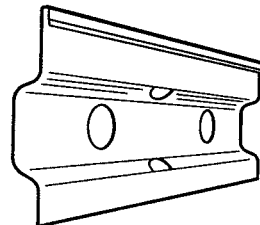

G-33 Screed Key Joint

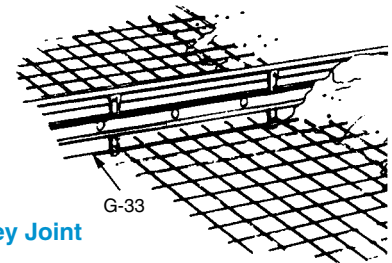

## G-27 Round Stake

Dayton Superior's G-27 Round Stakes are manufactured from high quality steel and feature a machined point and a spiral pattern of nailing holes. Available in 3/4" and 7/8" diameters in 12", 18", 24", 30", 36", 42" and 48" lengths.



G-27 Round Stake

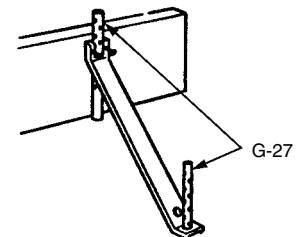

## FORM RELEASES

- Bio-Release EF
- Clean Strip (J-1-A)
- Clean Strip (J-1-A OTC)
- Clean Strip (J-1)
- Clean Strip (J-1 OTC)
- Clean Strip Gold (J-2)
- Clean Strip Ultra (J-3 V.O.C.)
- Clean Strip (J-3 PC)
- Clean Strip (J-3 PCU)
- Clean Strip WB (J-4)
- Liner Coat (J-4 LC)

## BONDBREAKERS

- Sure-Lift (J-6 WB)
- Sure-Lift (J-6)

## CURES & LIQUID HARDENERS

- White Disapating Cure EF
- White Pigmented Cure (J-8)
- Day-Chem White Pigmented Cure-W (J-9-A)
- Day-Chem White Pigmented Cure (J-10-W)
- Day-Chem Rez Cure (J-11-W)
- Clear Dissipating Cure EF
- Crete-Cure Concentrate (J-12)
- Cure & Seal 30 EF
- Day-Chem Sil-Cure (J-13)
- Day-Chem Hardener (J-15)
- Day-Chem Sure-Hard (J-17)

## CURES & SEALS

- Safe Cure & Seal (J-18)
- Safe Cure & Seal: 25% (J-22 WB)
- Safe Cure & Seal: 30% (J-19)
- General Purpose Cure & Seal (J-20)
- Cure & Seal 30 EF
- Day-Chem Cure & Seal: 1315 (J-22)
- Day-Chem Cure & Seal U.V.: 1315 (J-22 U.V.)
- Day-Chem Cure & Seal: 30% (J-23)
- Day-Chem Cure & Seal U.V.: 30% (J-23 U.V.)

## SEALERS

- Safe Seal (J-24)
- Safe Seal Heavy Duty (J-24 H.D.)
- Ultra Seal EF
- Day-Chem Aggre-Gloss (J-25)
- Day-Chem Aggre-Gloss (J-25-OTC)
- Day-Chem Anti-Spall (J-33)
- Day-Chem Tuf Seal (J-35)
- Day-Chem Tuf Seal (J-35 OTC)

## EPOXY & URETHANE FLOOR COATINGS

- Spec Cote 100
- Spec Cote 100 CR
- Spec Cote WB
- Spec Cote Urethane

## WATER REPELLENTS

- Weather Worker WB (J-26 WB)
- Weather Worker Heavy Duty WB (J-27 WB)
- Weather Worker S-40 (J-29)
- Weather Worker S-40 WB (J-29 WB)
- Weather Worker S-100 (J-29-A)

## BONDING AGENTS & LATEX ADDITIVES

- Day-Chem Ad Bond (J-40)
- Superior Concrete Bonder (J-41)
- Levelayer Bonding Agent (J-42)
- (For epoxy bonding agent, see Section 12 on epoxies)

## CLEANERS & STRIPPERS

- Citrus Peel (J-48)
- Green Bean Clean

## EPOXIES

- Epoxies Selection Guide
- Sure-Anchor Epoxy (J-50)
- Sure-Anchor I (J-51)
- Poxy-Fil (J-52)
- Sure-Grip High Flow Epoxy Grout (J-55)
- Sure-Inject (J-56) Sure Level Epoxy (J-57)
- Resi-Bond (J-58)
- Rebar Epoxy Spray (J-62)

## EVAPORATION & SURFACE RETARDERS

- Sure Etch (J-73)
- Sure Film (J-74)

## SEALANTS & EXPANSION JOINTS

- Perma 230 SL
- Day-Flex Expansion Joint

## POLYUREA JOINT FILLER & CONCRETE REPAIR

- CM 2000
- Joint Fill

## NON-SHRINK GROUTS

- Sure-Grip High Performance Grout
- 1107 Advantage Grout
- Sure-Grip Grout Dri-Pak
- Sure-Grip Utility Grout
- (For epoxy grout, see section 12 on epoxies)

## REPAIR MORTARS

- Civil/Structural VO
- Civil/Structural FPX
- HD-50
- HD-45
- Day-Chem Perma Patch
- Thin Resurfacer
- HD-25
- Polyfast LPL & FS
- Re-Crete 5 & 20 Minute Patch
- Waterstop & Fast Set
- Ankertite
- Architectural Finish

## SHAKE-ON FLOOR HARDENERS & TOPPINGS

- Emery Tuff
- Ferro Tuff
- Ferro Tuff Light Reflective
- Quartz Tuff
- Emery Tuff Top
- Emery Non-Slip

## FLOOR LEVELERS

- Levelayer (formerly Levelayer I)
- EconoLevel (formerly Levelayer II)
- Level Topping (formerly Levelayer III)
- Level Topping EXT (formerly Levelayer IV)
- Sure Finish
- Sure Patch

## MASONRY & CONCRETE COATINGS

- Seal Coat 1000
- Smooth Coat

## DIAMOND POLISH FLOOR SYSTEMS

- Day-Chem Sure Hard J-17DP
- DP Maintenance Cleaner
- DP Maintenance Cleaner Plus
- DP Maintenance Refresher
- DP Maintenance SS

The following pages feature a small selection of the chemical and cement products available from Dayton Superior. For a complete listing visit [daytonsuperior.com](http://daytonsuperior.com)

## FORM RELEASE

### Bio-Release EF

#### Earth Friendly Premium Form Release

Earth friendly (EF) concrete form release agent. Truly green, biodegradable material containing no petroleum products. Product is a water based formula containing 0 VOC's, making it VOC compliant in all regions.

Bio-Release EF is ideal for architectural concrete, precast, and general forming applications. EF is non-staining and minimizes concrete dusting. Properly applied, product will not impede the adhesion of subsequent treatments to the concrete, including paints or coatings.



### Clean Strip™ Ultra (J-3 V.O.C.)

#### Premium Form Release

Clean Strip Ultra V.O.C. is Dayton Superior's premium, chemically reactive form release that is V.O.C. compliant. It is ideal for architectural and precast concrete as well as for general forming applications.

This top quality product promotes easy stripping, minimizes form cleanup, is non-staining, and reduces the number of surface air voids (bugholes) on regular and superplasticized concrete.



## CLEANERS & STRIPPERS

### Green Bean Clean

#### Soybean Based Gel Stripper

Green Bean Clean is an industrial strength, environmentally safe, soybean based gel stripper.

Designed to remove most sealers, cure & seals, urethanes, paint & varnish from concrete, masonry and wood. Green Bean Clean's thick gel consistency enables long dwell times to reduce number of applications and is ideal for both vertical and horizontal.



## CURE & BONDBREAKER

### Sure-Lift™ WB (J-6 WB)

#### Water Based Cure & BondBreaker

Sure-Lift WB is a water based, environmentally friendly cure and bondbreaker for tilt-up and lift slab construction.

As a bondbreaker, Sure-Lift WB is unsurpassed in providing a clean, easy lift. In performance testing, Sure-Lift WB required fewer pounds of pressure to release and lift panels than other brands. Sure-Lift WB is compatible with many solvent based adhesives used in installing carpet, tile, vinyl, and other floor coverings.

Sure-Lift WB, because it is chemically reactive, is also more resistant to rain and weather than other bondbreakers.



## CURES & LIQUID HARDENERS

### Day-Chem White Pigmented Cure-W (J-9-A)

#### Water Based-State D.O.T.-ASTM C-309

A true water based curing compound containing white pigments and other solids in suspension. Day-Chem White Pigmented Cure-W is a water based formulation and as a result, contains no organic solvents. It is environmentally safe and is V.O.C. compliant. Approved by numerous state D.O.T.'s.

#### Meets Specifications:

ASTM C-309, Type 2, Class A

AASHTO M-148, Type 2, Class A



### Day-Chem Rez Cure™ (J-11-W)

#### Resin Cure-Water Based-ASTM C-309

An all resin curing compound that is water based and V.O.C. compliant. It is a ready-to-use curing compound for use on freshly finished, horizontal and vertical concrete surfaces.

#### Meets Specifications:

ASTM C-309, Type 1, Class A & B

AASHTO M-148, Type 1, Class A & B

Also available with Red Fugitive Dye.

CRD-C-300 & State Formulations Available.



### Day-Chem Sure Hard™ (J-17)

#### Combination Hardening, Dustproofing and Sealing

A colorless, odorless solution of reactive chemicals in water which deeply penetrates concrete and masonry surfaces to seal, densify and harden them. Sure Hard is ideal for concrete floors because it makes them more durable and abrasion resistant in heavy traffic, and resists rubber tire marks. The treated Sure Hard floor actually acquires a more polished appearance over time. Sure Hard resists oil and water penetration and it will not make the concrete floor slippery. Sure Hard can be applied to new and old floors and is completely odor free.

#### Meets Specifications:

Depth of Penetration — 5mm into concrete

Water Absorption — ASTM C-642

Sure Hard — 3.4% in 24 hours

Leading Competitor — 4.25% in 24 hours

Compressive Strength — ASTM C-140

Concrete treated with Sure Hard —

3,910 psi (27 MPa) - average

Untreated concrete - 3,461 psi (23.9 MPa) - average

Water Vapor Transmission Rate - 217 grams/sq.ft./24 hours

**AVAILABLE WITH EXTENDED DUSTPROOFING WARRANTIES. U.S.D.A. Approved**



## CURES & SEALS

### Safe Cure & Seal™ (J-18, J-19)

#### Cure, Seal and Dustproof

Percent Solids Available: 18% (J-18), 30% (J-19)



Safe Cure & Seal is a water based acrylic copolymer containing 18% or 30% solids that offers outstanding curing, sealing and dustproofing for freshly finished concrete surfaces. The higher solids content forms a longer lasting surface coating with a higher gloss finish and it provides excellent cure performance.

This product dries to produce a non-yellowing, durable, clear film on concrete. Safe Cure & Seal is ideal for interior applications because it is free of noxious fumes and is nonflammable.

#### Meets Specifications:

ASTM C-156 (Method of testing for ASTM C-309)

ASTM C-309 Type 1, Class A & B

AASHTO M-148, Type 1, Class A & B

**Note:** Federal Specification TT-C-800 A has been cancelled and is officially replaced by ASTM C-309. Safe Cure & Seal: 30% (J-19) meets the obsolete specification TT-C-800A.

## WATER REPELLENTS

### Weather Worker™ WB (J-26 WB) Weather Worker™ WB Heavy Duty (J-27-WB)



#### Penetrating Water Based Siloxane

Weather Worker WB (J-26-WB) is a water based emulsion of siloxane (7% or 10% solids) that penetrates into concrete or masonry and provides true, long term, weatherproofing protection. The Weather Worker WB Heavy Duty (J-27-WB) version contains 20% solids.

Once Weather Worker WB penetrates the substrate, it chemically reacts with and bonds to the concrete or masonry surface. The invisible film formed by Weather Worker WB will “bead” water and protect the substrate many times longer than conventional coatings. Aside from its ability to “bead” water, it allows the substrate to “breathe” due to its moisture vapor permeability.

#### Meets Specifications:

N.C.H.R.P. Report 244 (20% Siloxane)

Series II - 87% Reduction in Chloride Ion Content

Vapor Transmission - Excellent - No moisture retained after 21 days.

Water Penetration Through Masonry

ASTM E-514 (10% Siloxane)

(With Simulated Wind Driven Rain At 62.5 mph, 100.6 kph)

Average Reduction in Leakage Rate - 83%

**AVAILABLE WITH LONG TERM WARRANTIES.**

## BONDING AGENT

### Day-Chem Ad Bond™ (J-40)

#### Bonding Agent & Latex Admixture



An excellent bonding agent consisting of acrylic latex emulsion used primarily for bonding new to new or new to old concrete in interior or exterior applications. Ad Bond is also extremely effective when used as an admixture with cementitious products such as patching compounds, coatings, or grouts.

As an admixture, Day-Chem Ad Bond not only promotes a strong bond but also greatly increases the strength, durability and resistance to moisture of the finished product.

#### Meets Specifications:

ASTM C 1042 - Bond strength of latex systems used with concrete - Type II

#### Test Age

28 days

#### Bond Strength

2,436 psi (16.8 MPa)

ASTM C 1059 - Latex agents for bonding fresh to hardened concrete - Type II

## EPOXY ADHESIVE

### Sure-Anchor I™ (J-51)

#### Epoxy Gel Adhesive, I.C.B.O. Listed



Sure-Anchor I is a 100% solids, high modulus, high strength, fast setting, epoxy gel adhesive. It is a two component, moisture insensitive structural epoxy adhesive that meets ASTM C-881 and is listed by I.C.B.O.

Sure-Anchor I is available in cartridges for easy dispensing, as well as larger, gallon units. Sure-Anchor I is ideal for anchoring bolts, dowels, and reinforcing steel into concrete. It is also ideal for vertical and horizontal structural bonding and patching.

Sure-Anchor I may be used to seal cracks and set injection ports prior to injection grouting.

#### Meets Specifications:

ASTM C-881, Type I, II, IV, V, Grade 3, Class B & C

Compressive Strength - ASTM D-695:

10,600 psi (73 MPa) at 7 days

Concrete Bond Strength - ASTM C-882:

3,000 psi (20 MPa) at 14 days

## NON-SHRINK GROUT

### 1107 Advantage Grout™

#### Non-shrink, Non-metallic Cement Based Grout

1107 Advantage Grout is a non-shrink, non-corrosive, non-metallic grout. It is formulated as a cement based product with high quality raw materials. 1107 Advantage Grout offers the advantages of pump ability and heat and thermal shock resistance, while providing a controlled, net positive expansion. 1107 Advantage is designed for interior and exterior grouting of precast concrete components, structural column base plates, pump and machinery bases, anchoring bolts, rebars, dowels, bearing pads, keyway joints and crane rails. It also finds applications in paper mills, oil refineries, food plants, chemical plants as well as sewage and water treatment plants. It can be used as a patching material for minor repairs or for filling tie-holes in concrete.

It also finds applications in paper mills, oil refineries, food plants, chemical plants as well as sewage and water treatment plants. It can be used as a patching material for minor repairs or for filling tie-holes in concrete.

### Meets Specifications:

Corps of Engineers Specification for Non-shrink Grout: CRD-C 621  
ASTIVI C-1 107, Grades A, B, C, ASTIVI C-827

## REPAIR MORTARS

### HD-50™

#### Rapid-Setting, Flowable Concrete Mortar

A latex-modified, fiber reinforced, fast setting concrete repair designed for horizontal areas where high strength and fast setting are required to minimize downtime. It is similar in performance to our Perma Patch, except that it is flowable.

		Test Results							
☐ Fluidity	Flow	Compressive Strength (psi)							
		1 Day		3 Day		7 Day		28 Day	
		psi	MPa	psi	MPa	psi	MPa	psi	MPa
Dry-Pack	—	5,000	(34.5)	7,000	(48.2)	9,000	(62.0)	10,000	(63.0)
Flowable	130%	2,500	(17.2)	5,000	(34.5)	6,000	(41.4)	8,000	(55.2)
Flowable	30 sec.	2,000	(13.8)	4,000	(27.6)	5,000	(34.5)	7,500	(51.7)

#### Compressive Strength - ASTM C-109

##### At 75 Degrees F

1 hour	2,500 psi	(17.2 MPa)
3 hours	3,500 psi	(24.1 MPa)
1 day	6,145 psi	(42.4 MPa)
7 days	7,370 psi	(50.8 MPa)
28 days	7,990 psi	(55.1 MPa)

#### Bond Strength - ASTM C-882

7 days	2,550 psi	(17.6 MPa)
--------	-----------	------------

#### Rapid Freeze/Thaw Test - ASTM C-666 B

At 300 Cycles - Samples indicated an average weight loss of .3% with no signs of spalling.

## Architectural Finish

### Cement based, polymer-modified material

Architectural Finish is a single component, cement based, polymer-modified material specially formulated for rubbing, smoothing, resurfacing, repairing and restoring concrete surfaces. Designed with additives for superior bonding characteristics for use on vertical or overhead applications. Material dries a light gray color and can be troweled hard or sanded to provide a smooth finish.

#### Compressive Strength - ASTM C-109 - At 75 Degrees F

7 days	5000 psi	(34.1 Mpa)
28 days	6000 psi	(41.3 Mpa)

## Re-Create™ 20 Minute Patch

### Cement Base Repair Material

An all-purpose patching material containing Portland Cement, special hardeners and set accelerators to provide a fast setting patch. Re-Create 20 Minute has an initial set of 15 minutes and a final set of 35 minutes. Re-Create remains plastic for about 15 minutes, permitting shaping and molding.

Re-Create is ideal for vertical and overhead patching with its putty-like consistency. It can be used to repair concrete pipes, precast concrete products, concrete steps, walls, ceilings and concrete blocks.

Colors: Gray and Light Gray.

#### Compressive Strengths - ASTM C-109

1 day	3,000 psi	(20.7 MPa)
3 days	5,100 psi	(35.2 MPa)
28 days	6,500 psi	(44.8 MPa)

## SELF-LEVELING FLOOR TOPPINGS

### LeveLayer

#### Premium Self-Leveling Floor Underlayment

Dayton Superior LeveLayer is a cement based, non-shrinking, self-leveling floor underlayment designed for interior use. This single component product by hydration results in a smooth subfloor that typically will accept floor coverings in as little as 14 hours after installation. Just mix LeveLayer with water, pour or pump, and it will seek its own level to produce a smooth, flat, hard surface.

LeveLayer can be used to level or create a smooth surface on interior floors. It can be used on new construction projects to correct rough, unfinished, or uneven floors. On restoration projects, use LeveLayer to produce a smooth, even finish over the existing substrate.

#### Compressive Strength - ASTM C-109

1 day	3,000 psi
7 days	4,000 psi
28 days	5,400 psi

### EconoLevel

#### Economical Self-leveling Floor Underlayment

Dayton Superior EconoLevel is a polymer-modified cement based self-leveling underlayment designed for interior use. This single component product by hydration results in a smooth subfloor that typically will accept floor coverings in as little as 14 hours after installation. Just mix EconoLevel with water, pour or pump, and it will seek its own level to produce a smooth, flat, hard surface.

EconoLevel can be used to level or create a smooth surface on interior floors. It can be used on new construction projects to correct rough, unfinished, or uneven floors. On restoration projects, use EconoLevel to produce a smooth, even finish over the existing substrate.

#### Compressive Strength - ASTM C-109

1 day	2,500 psi
7 days	3,500 psi
28 days	4,200 psi

### Level Topping™ (formerly LeveLayer III)

#### Heavy Duty Self-Leveling Floor Topping

Level Topping is Dayton Superior's premium, cement based, non-shrinking, self-leveling topping designed for traffic. This single component product provides a tough surface that typically accepts light traffic 24 hours after installation.

Level Topping can be used to level or create a solid surface on interior industrial type concrete floors. It can be used on new construction projects to correct rough or unfinished concrete and to level out uneven floors. Do not use outdoors.

#### Compressive Strength - ASTM C-109

1 day	3,000 psi	(20.7 MPa)
7 days	5,000 psi	(34.5 MPa)
28 days	7,000 psi	(48.3 MPa)

#### Abrasion Resistance - ASTM C-944

Load 20 Kfg	
Level Topping - Average Weight Loss	- 8.3 g.
Leading Competitor - Average Weight Loss	- 51.4 g.

	<p style="text-align: center;"> <b>DANGER</b></p> <p style="text-align: center;"><i>Improper Use of Concrete Accessories Can Cause Severe Injury or Death</i></p> <p style="text-align: center;"><i>Read, understand and follow the information and instructions in this publication before using any of the Dayton Superior concrete accessories displayed herein. When in doubt about the proper use or installation of any Dayton Superior concrete accessory, immediately contact the nearest Dayton Superior Service Center or Technical Service Department for clarification.</i></p> <p style="text-align: center;"><i>See inside back cover for your nearest location.</i></p>
---	---

Dayton Superior products are intended for use by trained, qualified and experienced workmen only. Misuse or lack of supervision and/or inspection can contribute to serious accidents or deaths. Any application other than those shown in this publication should be carefully tested before use.

The user of Dayton Superior products must evaluate the product application, determine the safe working load and control all field conditions to prevent applications of loads in excess of a product's safe working load. Safety factors shown in this publication are approximate minimum values. The data used to develop safe working loads for products displayed in this publication are a combination of actual testing and/or other industry sources. Recommended safe working loads given for the products in this publication must never be exceeded.

## Worn Working Parts

For safety, concrete accessories must be properly used and maintained. Concrete accessories shown in this publication may be subject to wear, overloading, corrosion, deformation, intentional alteration and other factors that may affect the device's performance. All reusable accessories must be inspected regularly by the user to determine if they may be used at the rated safe working load or should be removed from service. The frequency of inspections depends upon factors such as (but not limited to) the amount of use, period of service and environment. It is the responsibility of the user to schedule accessory hardware inspections for wear and to remove the hardware from service when wear is noted.

## Shop or Field Modification

Welding can compromise a product's safe working load value and cause hazardous situations. Knowledge of materials, heat treating and welding procedures is necessary for proper welding. Consult a local welding supply dealer for assistance in determining required welding procedures.

DO NOT WELD TO ANY CASTING unless approved by a licensed metallurgical engineer. Welding to an iron casting may cause carbides and extreme brittleness which destroy most of the casting's load value.

Since Dayton Superior cannot control workmanship or conditions in which modifications are done, Dayton Superior cannot be responsible for any product altered in the field.

## Interchangeability

Many concrete accessory products that Dayton Superior manufactures and supplies are designed as part of a system. Dayton Superior strongly discourages efforts to interchange products supplied by other manufacturers with components supplied by Dayton Superior. When used properly, and in accordance with published instructions, Dayton Superior products have proven to be among the best designed and safest in the industry. Used improperly or with incompatible components supplied by other manufacturers, Dayton Superior products or systems may be rendered unsafe.

## Design Changes

Dayton Superior Concrete Accessories reserves the right to change product designs, rated loads and product dimensions at any time without prior notice.

**Note:** See Safety Notes and Safety Factor Information on Page 4



We have the most complete dealer network in North America.  
For the dealer nearest your project, simply call the office in your region.

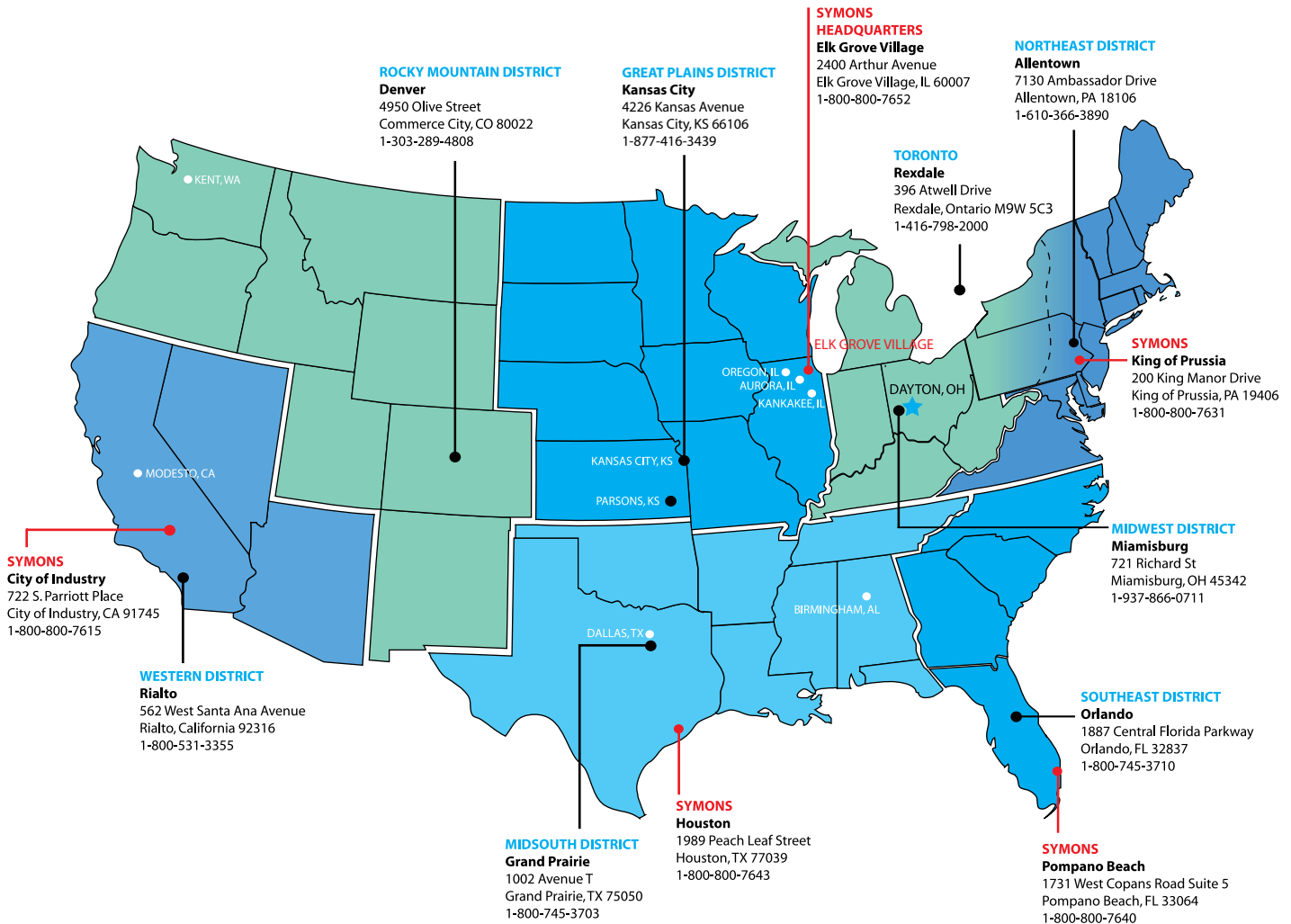

DAYTON SUPERIOR CORPORATION  
7777 WASHINGTON VILLAGE DRIVE, SUITE 130  
DAYTON, OH 45459  
PHONE: 937-428.6360  
TOLL FREE: 877-632.9866  
FAX: 937-428.9560  
DAYTONSUPERIOR.COM

BUILDING STRENGTH