

# BUILDER'S REFERENCE GUIDE

Building Successfully With  
Dryvit Residential Systems



DS504

## INTRODUCTION

“Building Successfully with Dryvit EIFS” is a reference guide for builders, architects and other professionals in the building industry, who deal with exterior insulation and finish systems.

The information contained in this guide is intended to help building professionals ensure quality in their EIFS installations. It can serve as a planning tool as well as a convenient reference source on essential components of a successful EIFS job.

This guide is not intended to act as a substitute for Dryvit’s written specifications, application instructions and details. Copies of those items are available by calling 1-800-556-7752. Furthermore, since designs can vary greatly from project to project, we urge you to consult with a design professional if you have concerns. Of course, you can always call Dryvit if you have technical questions relating to our products.

Dryvit, the EIFS industry leader for more than 30 years, is pleased to bring you this guide as part of its ongoing commitment to quality and customer satisfaction.

## THE FOLLOWING IS A LIST OF MAJOR CONSIDERATIONS THAT WILL HELP ENSURE A QUALITY DRYVIT INSTALLATION.

### SUBSTRATES (INSPECTION/WALK-AROUND)

Prior to starting a job, it is important that the EIFS contractor and the builder or representative walk around the project to inspect and check the structure - making sure the walls and corners are in plane and that the approved substrate and flashing is in good condition and properly installed per local building code requirements.

### TERMINATIONS/FOUNDATION

Provide adequate clearance so that the Dryvit system can terminate a minimum of 200 mm (8”) above grade or as required by local code. This is important to allow for proper inspection by pest control operators. All terminations require backwrapping unless Starter Track™ with weep holes is used. Backwrapping is defined as the continuation of the reinforced base coat across the face and edge of the insulation board. The reinforcing mesh is continued onto the back side of the insulation board a minimum of 64 mm (2-1/2”).

### EXPANSION JOINTS

**Dissimilar Materials** - When the system terminates against a dissimilar material, such as wood or concrete, the system shall be held back a minimum of 19 mm (3/4”) to allow for an expansion joint and caulking.

**Floor Lines** - In wood-framed construction, expansion joints are installed at each floor line to allow for framing shrinkage.

**Other** - Expansion joints should be included at areas where there is a change in substrate that could result in differential movement, at areas with significant movement, at expansion joints in the substrate or building, or where the design professional requires.

## **PENETRATIONS**

Terminations at penetrations, such as windows, doors, light fixtures, hose bibs, dryer vents, wall receptacles, etc. require backwrapping with reinforcing mesh and base coat. The insulation board must be held back from the opening a minimum of 13 mm (1/2") for proper sealant installation. A fillet bead of sealant is permitted around small penetrations such as hose bibs, etc.

## **DECK FLASHING**

Deck flashing should be installed to preclude water entry. In addition, flash the top edge of the Dryvit system if it is cut to accommodate the header joist. Use good construction practices for flashing and sealant installation to ensure watertightness. Dryvit details are for general information and guidance only.

## **WINDOW FLASHING**

Not all windows are created equal. It is important to use good quality code-compliant windows. Windows can be a significant contributor to water intrusion. Windows should be flashed and caulked per window manufacturers' recommendations to prevent water entry.

## **ROOF INTERSECTING VERTICAL WALL**

A kickout or diverter flashing must be installed as the first piece of flashing at the end of the roof where it intersects the wall. All diverter joints must be soldered. Step flashing is to extend up the wall at least 150 mm (6"). The purpose of the flashing and diverter is to shed the water off the roof and keep it out of the vertical wall beneath.

## **SOFFIT RETURNS/GABLE ENDS**

When frieze boards are to be installed, install the Dryvit system first; the frieze boards are installed over the Dryvit system and sealed as required.

## **CRICKETS/CHIMNEY ENCLOSURE**

Cricket are designed to deter the accumulation of snow and ice and deflect water around a chimney. To finish masonry enclosures, it is recommended that a skim coat of base coat be applied prior to application of finish. Use of insulation is not recommended due to possible heat buildup. The wood-enclosed chimney chase can be finished with a full Dryvit system with EPS insulation. Flashing should continue vertically 150 mm (6") above the cricket. Flashing at the top of the enclosure must also be installed.

## **SEALANTS**

Expansion joints and terminations at windows and other openings must be properly sealed. Use closed-cell backer rod, sealant primer and sealant. Consult the following manufacturers to verify that they have tested their sealants for compatibility with EIFS:

Dryvit Systems, Inc.

Sealant: DSI 320

Primer: DSI 300\*

Tremco, Inc.

Sealant: Dymeric 511

Primer: No.1\*

Pecora Corporation  
Sealant: Dynatrol II  
Primer: Type 75 or 150\*

Pecora Corporation  
Sealant: 890 Silicone  
Primer: P64\*

Tremco, Inc.  
Sealant: Spectrem 1 and 3  
Primer: Primer 23\*

Sika Corporation  
Sealant: Sikaflex 2C  
Primer: Sikaflex 429\*

Dow Corning  
Sealant: Dow Corning 790, 791\*\*, 795\*\*  
Primer: Dow Corning 1200\* Prime Coat

GE  
Sealant: Silpruf LM (scs 2700)  
Primer: SCP 3195P\*

\*Primer is for sealing Dryvit to Dryvit. For sealing Dryvit to other materials, consult with sealant manufacturer.

\*\*Dow Corning 791 and 795 are intended to be used as perimeter seals and at penetrations. They are not intended to be used when sealing Dryvit to Dryvit.

## **AVOIDING WATER**

Water intrusion into the exterior wall of any structure can lead to problems; therefore, attention must be paid to following proper details to minimize the risks.

Traditional EIFS are barrier-wall systems designed to keep water out of the structure just like other components that make up the exterior envelope. Dryvit offers an EIFS design that incorporates a secondary weather barrier and a drainage plane. Incidental moisture that may enter around the system reaching the secondary weather-resistant barrier harmlessly drains out of the wall. However, the critical step with all exterior siding in eliminating potential moisture problems is planning for and executing properly the interfacing of the Dryvit system with all other adjacent building components.

It is important that the builder, EIFS contractor, roofer and framer together review all construction details and documents that relate to the interfacing of the different exterior systems and components that make up the envelope of the house before starting construction.

Dryvit strongly urges EIFS contractors not to begin work on a project in which the construction requirements for EIFS application have not been fulfilled.

**WE AT DRYVIT ASK OUR EIFS CONTRACTORS TO INSIST ON THE FOLLOWING BEFORE STARTING AN EIFS INSTALLATION.**

**Weather Barrier** - A code-approved weather-resistant barrier shall be installed horizontally overlapping the course below in a weatherboard fashion. The minimum overlap is dictated by the applicable building code.

**Ambient Temperature Requirements** - A minimum temperature of 4 °C (40 °F) and rising during installation and 24 hours thereafter shall be maintained.

**Substrates** - Wall sheathing shall be securely fastened per applicable building code. There shall be no planar irregularities greater than 6.4 mm (1/4 in) within any 1.2 m (4 ft) radius.

**Flashing at Openings** - All openings shall be properly flashed per project design documents. Individual windows, that are ganged to make multiple units, shall have continuous flashing and/or joints between them and shall be fully sealed.

**Decks** - Provisions shall be made to ensure that the Dryvit system can be properly terminated above grade and at patios, decks, landings, etc. and that the required flashing is in place.

**Roof** - Ensure that the roof has positive drainage, i.e., crickets or saddles. Metal roof flashing shall be installed in accordance with the guidelines set by the Asphalt Roofing Manufacturers Association (ARMA). Run-off diverters, i.e., kick-outs, must be installed where required.

**Utilities** - Provisions must be made to ensure that the system terminates properly at lighting fixtures, electrical outlets, hose bibs, dryer vents, etc.

### **THE *BUILDER* SERIES: NINE CRITICAL AREAS THAT DESERVE A CLOSER LOOK**

The following pages contain nine advertisements that have appeared in *BUILDER* magazine as part of an educational campaign by Dryvit. Each of these ads focuses on a specific aspect of construction in which good planning and coordination between trades is important to a quality building envelope. Detailed drawings show how to ensure a quality job. Other alternatives, generated by design professionals, may be appropriate. Dryvit publishes comprehensive specifications, application instructions and details. This guide is not to be used in lieu of the more comprehensive information. Copies of those documents are available free of charge by calling 1-800-556-7752. Technical Service representatives can also answer any questions concerning the application and details of the Dryvit products.

Details Are The Key To Success

# FLASHING WHERE ROOF AND VERTICAL WALL MEET

## SUCCESSFUL BUILDERS SHARE THEIR KNOWLEDGE

All good builders know how important it is to pay attention to details. In this series, Dryvit focuses on key details that successful builders follow when installing exterior insulation and finish systems. Use these drawings, along with Dryvit's complete system specifications and details, as a helpful guide for you and your subcontractors in planning and coordinating the critical interfaces between exterior building components.

## DRYVIT'S TECHNICAL SUPPORT IS TOPS

Throughout North America, we have a field service staff to assist with technical issues. Our corporate engineering staff is prepared to review your Dryvit plans, make suggestions and support your efforts. Total customer satisfaction is our goal. Use our 800 number and benefit from the Dryvit Difference.

## MAKE SURE IT'S A DRYVIT SYSTEM

We are the Number One EIFS manufacturer. We offer a number of exterior wall systems including Residential MD® and Sprint MD® Systems. You are off to a great start when you select a Dryvit system.

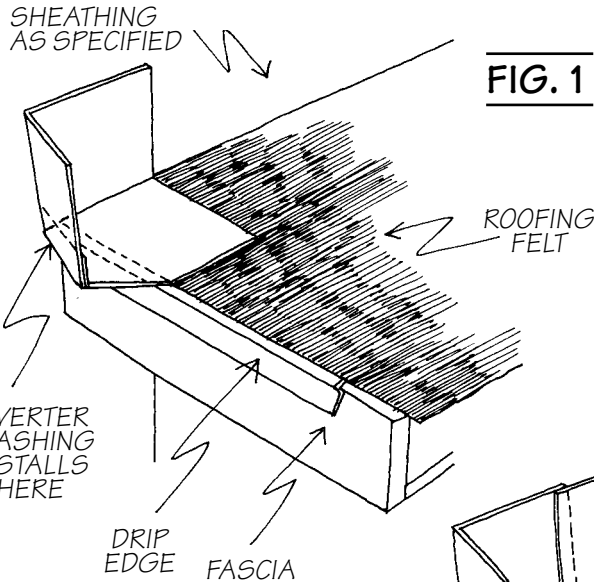

FIG. 1

**Fig. 1)** A diverter flashing is installed as the first piece of flashing at the end of the roof where it intersects the wall.

**Fig. 2)** This detail shows the installation of the diverter and step flashing. The purpose of the step flashing and diverter is to shed the water off the roof and keep it away from the vertical wall beneath.

Note: All diverter joints must be soldered.

**Fig. 3)** The Dryvit system is held a minimum of 2" off the roof and caulked around the diverter.

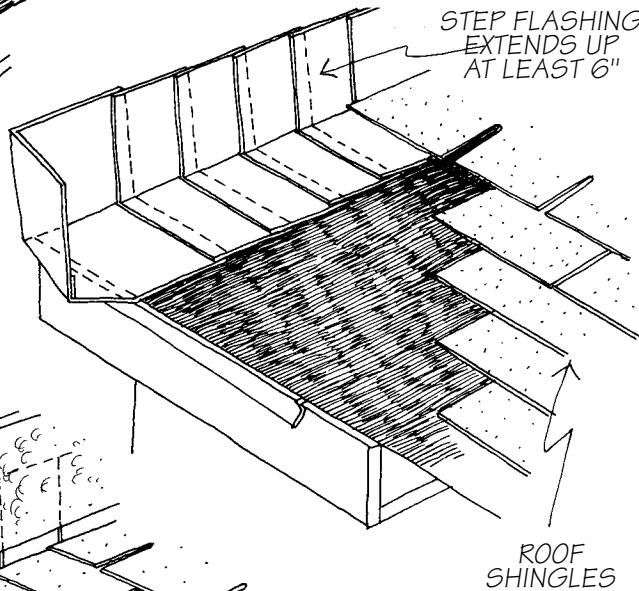

FIG. 2

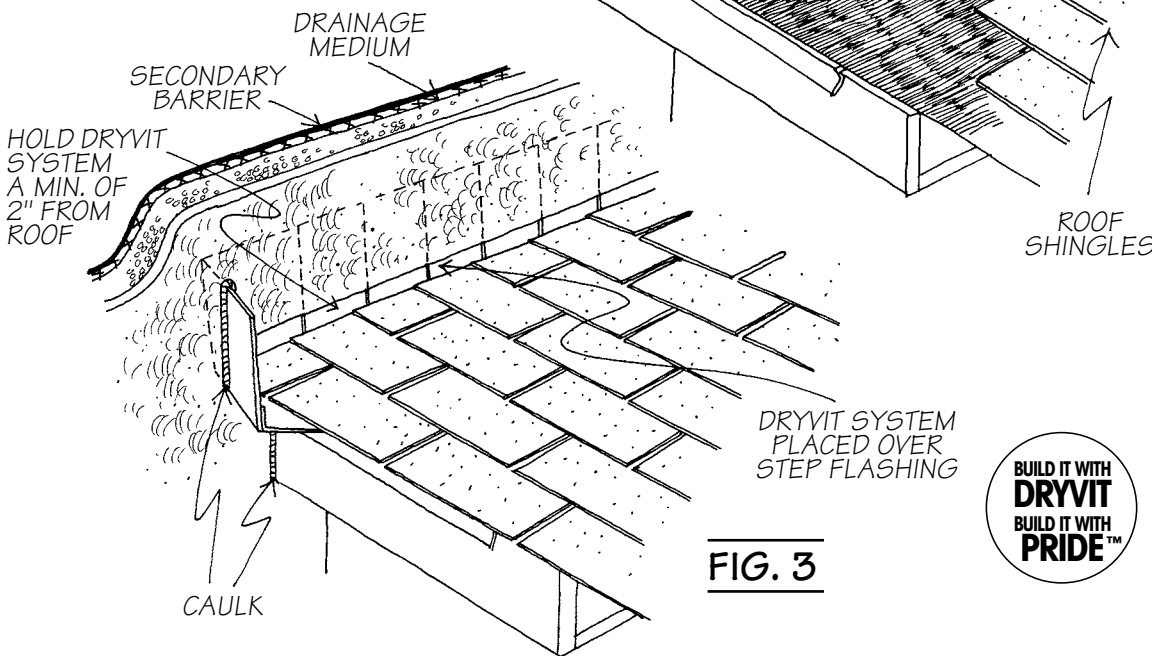

FIG. 3



This detail is for general information and guidance only, and Dryvit disclaims any liability for the use of this detail and for the architecture, design, engineering or workmanship of any project.

For additional information, call 1-800-4-DRYVIT or visit [www.dryvit.com](http://www.dryvit.com)

©Dryvit Systems, Inc. 1997



An RPM Company

Details Are The Key To Success

# TERMINATIONS ABOVE GRADE

**FIG. 1**

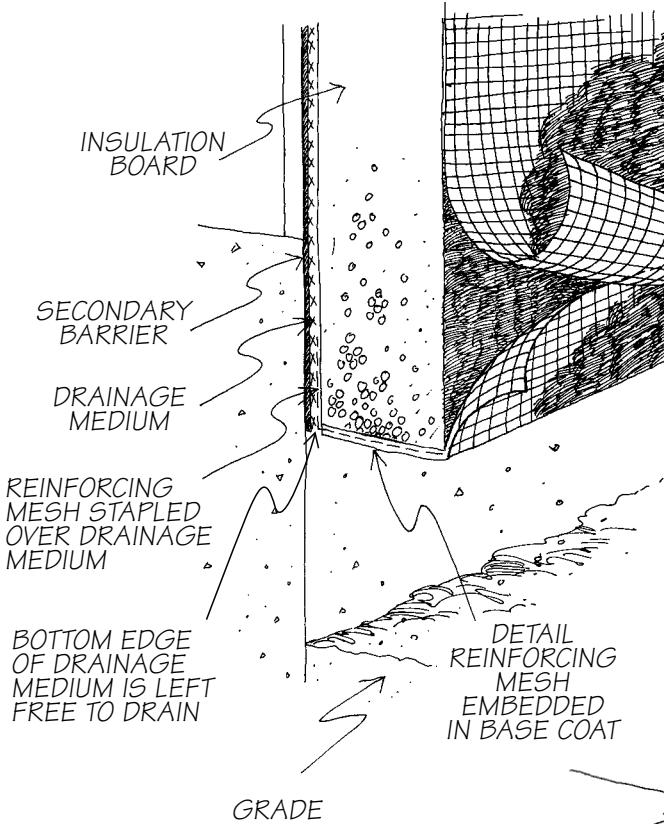
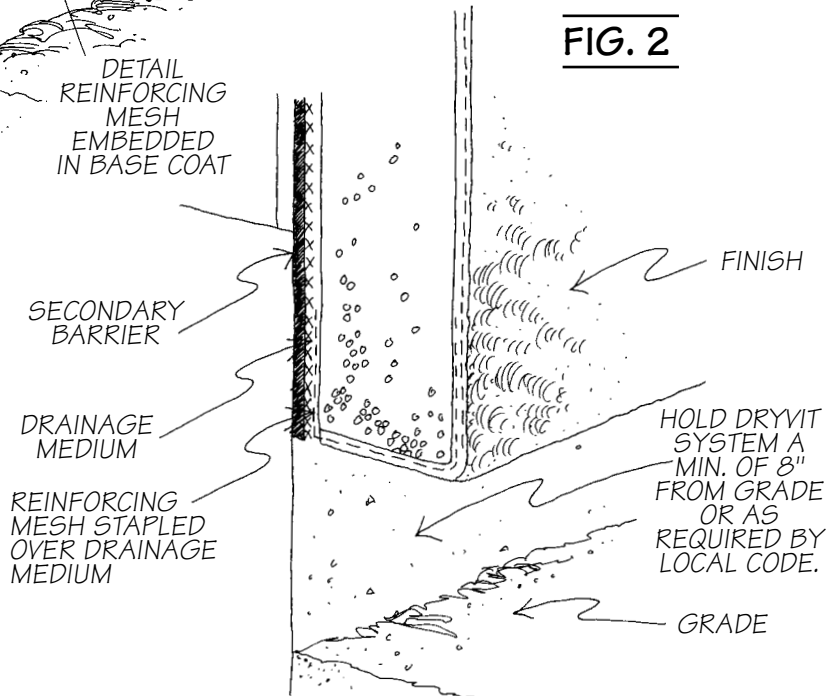

**Fig. 1)** This detail shows proper backwrapping which shall be done at all terminations. The Detail® mesh underlaps the reinforcing mesh on the face of the wall by a minimum of 2½".

**Fig. 2)** The Dryvit system is terminated a minimum of 8" above finished grade or as required by local code.

REINFORCING MESH (AS SPECIFIED) EMBEDDED IN BASE COAT

**FIG. 2**



HOLD DRYVIT SYSTEM A MIN. OF 8" FROM GRADE OR AS REQUIRED BY LOCAL CODE.

## SUCCESSFUL BUILDERS SHARE THEIR KNOWLEDGE

All good builders know how important it is to pay attention to details. In this series, Dryvit focuses on key details that successful builders follow when installing exterior insulation and finish systems. Use these drawings, along with Dryvit's complete system specifications and details, as a helpful guide for you and your subcontractors in planning and coordinating the critical interfaces between exterior building components.

## DRYVIT'S TECHNICAL SUPPORT IS TOPS

Throughout North America, we have a field service staff to assist with technical issues. Our corporate engineering staff is prepared to review your Dryvit plans, make suggestions and support your efforts. Total customer satisfaction is our goal. Use our 800 number and benefit from the Dryvit Difference.

## MAKE SURE IT'S A DRYVIT SYSTEM

We are the Number One EIFS manufacturer. We offer a number of exterior wall systems including Residential MD® and Sprint MD® Systems. You are off to a great start when you select a Dryvit system.



This detail is for general information and guidance only, and Dryvit disclaims any liability for the use of this detail and for the architecture, design, engineering or workmanship of any project.

For additional information, call 1-800-4-DRYVIT or visit [www.dryvit.com](http://www.dryvit.com)

©Dryvit Systems, Inc. 1997



An RPM Company

# Details Are The Key To Success FLASHING AT CHIMNEY AND CRICKET

**FIG. 1**

PREFABRICATED CHIMNEY

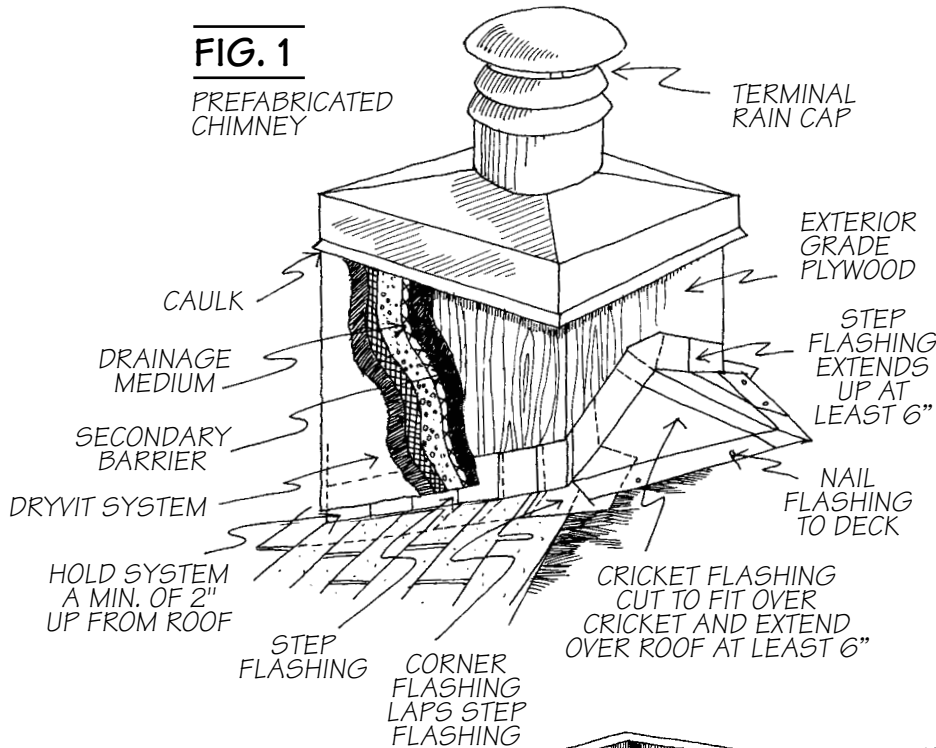

**Fig. 1)** This detail shows chimney with plywood and all associated roof flashing finished with Dryvit system held up a minimum of 2" from roof.

**Fig. 2)** This detail shows a masonry chimney with associated roof flashing, counter flashing and cap. Shown with skimmed Dryvit base coat and Dryvit finish. Note: Use of EPS insulation is not recommended on masonry chimneys.



**FIG. 2**

MASONRY CHIMNEY

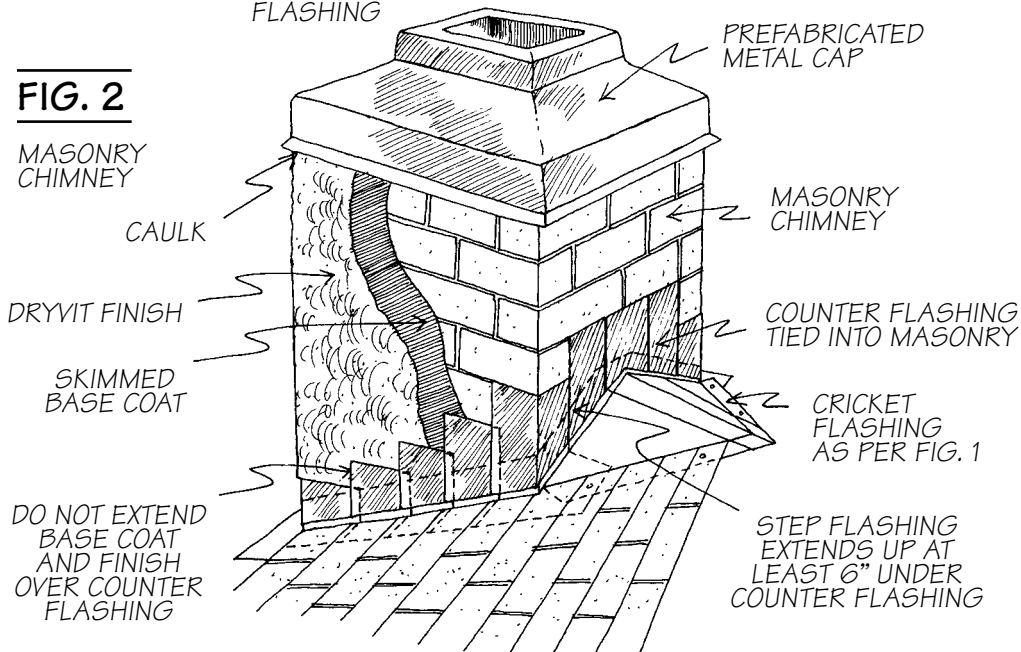

## SUCCESSFUL BUILDERS SHARE THEIR KNOWLEDGE

All good builders know how important it is to pay attention to details. In this series, Dryvit focuses on key details that successful builders follow when installing exterior insulation and finish systems. Use these drawings, along with Dryvit's complete system specifications and details, as a helpful guide for you and your subcontractors in planning and coordinating the critical interfaces between exterior building components.

## DRYVIT'S TECHNICAL SUPPORT IS TOPS

Throughout North America, we have a field service staff to assist with technical issues. Our corporate engineering staff is prepared to review your Dryvit plans, make suggestions and support your efforts. Total customer satisfaction is our goal. Use our 800 number and benefit from the Dryvit Difference.

## MAKE SURE IT'S A DRYVIT SYSTEM

We are the Number One EIFS manufacturer. We offer a number of exterior wall systems including Residential MD® and Sprint MD® Systems. You are off to a great start when you select a Dryvit system.

This detail is for general information and guidance only, and Dryvit disclaims any liability for the use of this detail and for the architecture, design, engineering or workmanship of any project.

For additional information, call 1-800-4-DRYVIT or visit [www.dryvit.com](http://www.dryvit.com)



Details Are The Key To Success

# FLASHING WHERE DECK AND VERTICAL WALL MEET

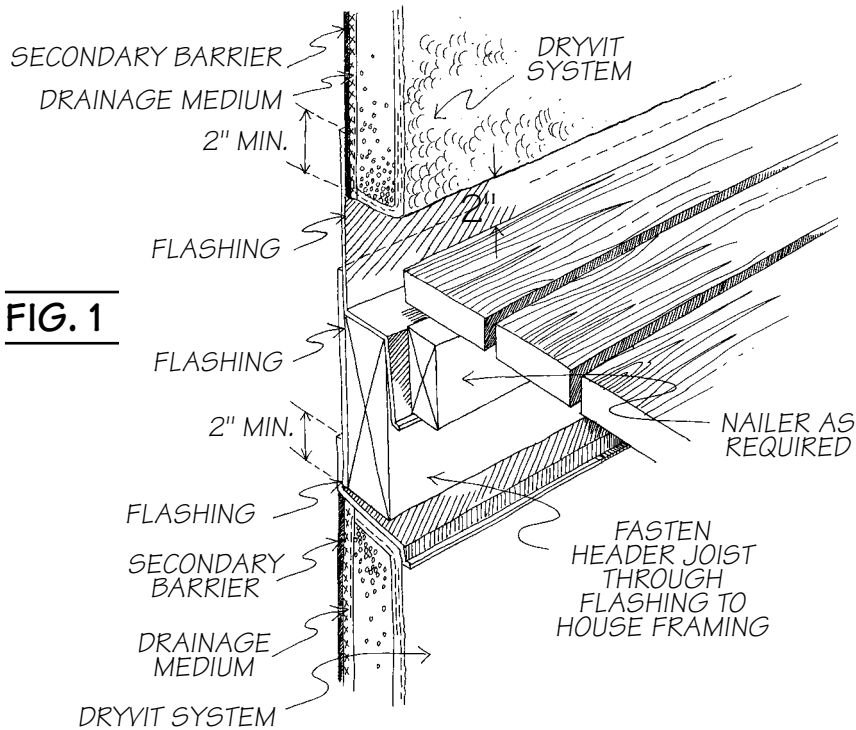

**FIG. 1**

**Fig. 1)** Hold Dryvit system a minimum of 2" up from decking. Extend flashing 2" behind system. Decking should be fastened so as not to penetrate flashing.

**Fig. 2)** Hold Dryvit system back a minimum of 2" from deck end joist to allow for proper caulking. System terminations below deck shall be encapsulated with reinforcing mesh, base coat and finish.



## SUCCESSFUL BUILDERS SHARE THEIR KNOWLEDGE

All good builders know how important it is to pay attention to details. In this series, Dryvit focuses on key details that successful builders follow when installing exterior insulation and finish systems. Use these drawings, along with Dryvit's complete system specifications and details, as a helpful guide for you and your subcontractors in planning and coordinating the critical interfaces between exterior building components.

## DRYVIT'S TECHNICAL SUPPORT IS TOPS

Throughout North America, we have a field service staff to assist with technical issues. Our corporate engineering staff is prepared to review your Dryvit plans, make suggestions and support your efforts. Total customer satisfaction is our goal. Use our 800 number and benefit from the Dryvit Difference.

## MAKE SURE IT'S A DRYVIT SYSTEM

We are the Number One EIFS manufacturer. We offer a number of exterior wall systems including Residential MD® and Sprint MD® Systems. You are off to a great start when you select a Dryvit system.

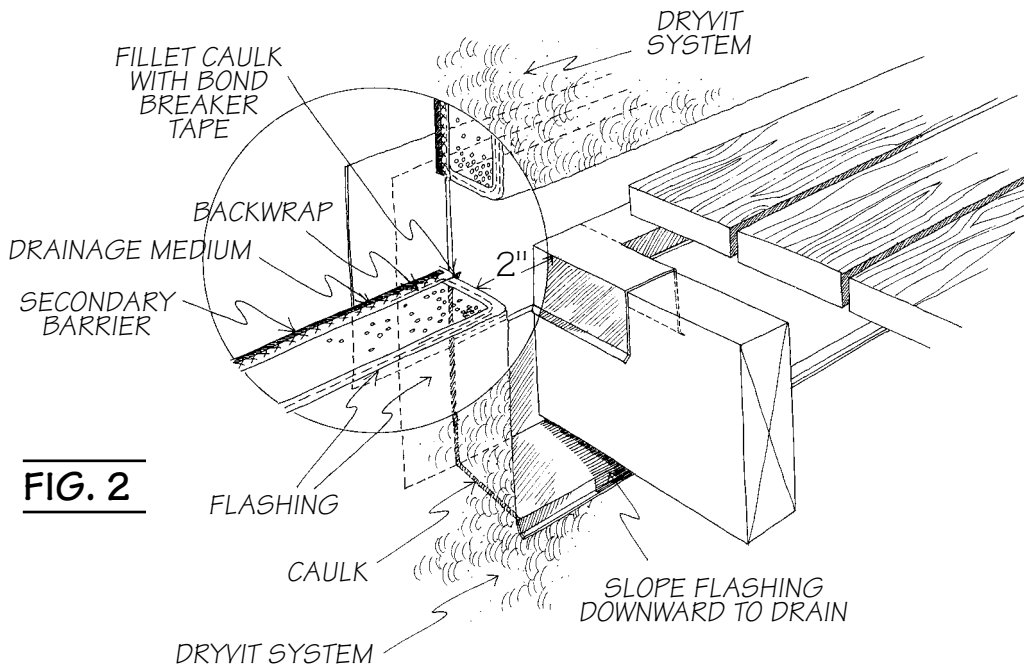

**FIG. 2**

This detail is for general information and guidance only, and Dryvit disclaims any liability for the use of this detail and for the architecture, design, engineering or workmanship of any project.

For additional information, call 1-800-4-DRYVIT or visit [www.dryvit.com](http://www.dryvit.com)

©Dryvit Systems, Inc. 1997



An RPM Company

# Details Are The Key To Success FLASHING AT DORMER

## SUCCESSFUL BUILDERS SHARE THEIR KNOWLEDGE

All good builders know how important it is to pay attention to details. In this series, Dryvit focuses on key details that successful builders follow when installing exterior insulation and finish systems. Use these drawings, along with Dryvit's complete system specifications and details, as a helpful guide for you and your subcontractors in planning and coordinating the critical interfaces between exterior building components.

## DRYVIT'S TECHNICAL SUPPORT IS TOPS

Throughout North America, we have a field service staff to assist with technical issues. Our corporate engineering staff is prepared to review your Dryvit plans, make suggestions and support your efforts. Total customer satisfaction is our goal. Use our 800 number and benefit from the Dryvit Difference.

## MAKE SURE IT'S A DRYVIT SYSTEM

We are the Number One EIFS manufacturer. We offer a number of exterior wall systems including Residential MD® and Sprint MD® Systems. You are off to a great start when you select a Dryvit system.

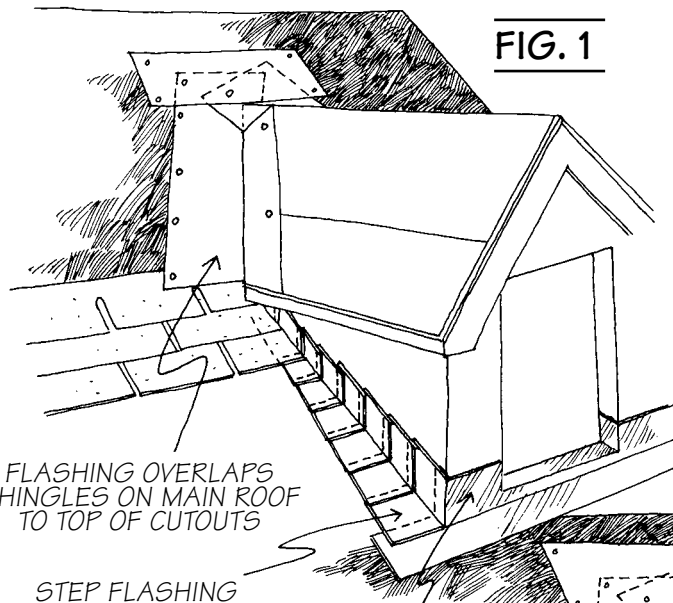

FIG. 1

**Fig. 1)** Install dormer step and valley flashing and dormer to roof flashing. Where window is close to roof line, continue flashing into opening.

**Fig. 2)** Install window and seal to opening and roof flashing. Flashing at window head to be provided as required depending on specific window used.

**Fig. 3)** Shows Dryvit system properly installed a minimum of 2" up from roof. System is held back a minimum of 1/2" from window frame to allow for backer rod and caulking.

FLASHING OVERLAPS SHINGLES ON MAIN ROOF TO TOP OF CUTOUTS

STEP FLASHING

DORMER TO ROOF FLASHING

ROOF SHINGLES

FIG. 2

FIG. 3

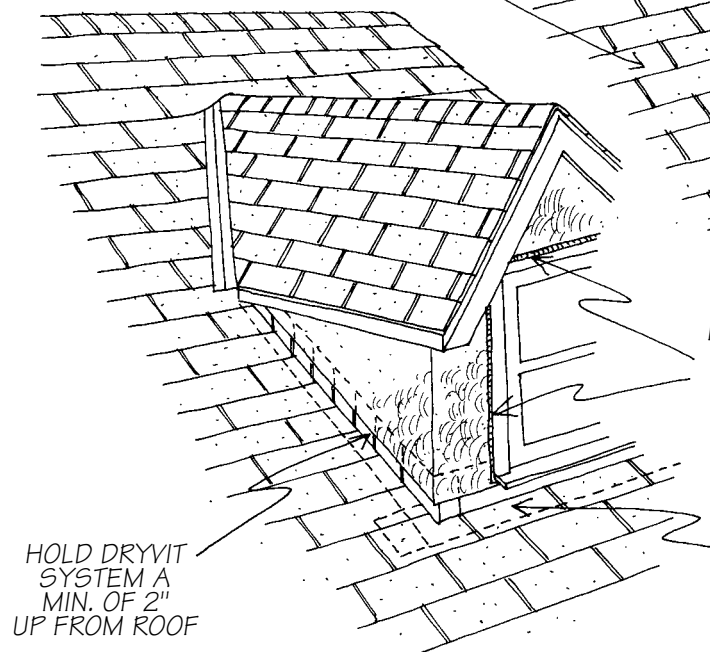

BACKER ROD AND CAULK AND/OR FLASHING

ADHERE SHINGLES TRIMMED TO COVER FLASHING STRIP

HOLD DRYVIT SYSTEM A MIN. OF 2" UP FROM ROOF



This detail is for general information and guidance only, and Dryvit disclaims any liability for the use of this detail and for the architecture, design, engineering or workmanship of any project.

For additional information, call 1-800-4-DRYVIT or visit [www.dryvit.com](http://www.dryvit.com)

©Dryvit Systems, Inc. 1997



An RPM Company

# Details Are The Key To Success

## ATTACHMENT OF SHUTTERS AND DOWNSPOUTS

**FIG. 1**

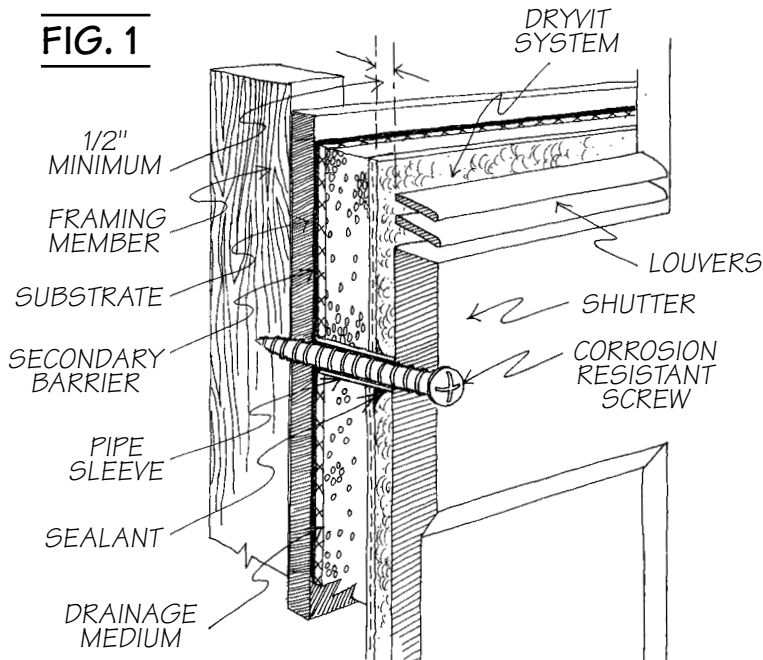

Wherever the system is penetrated for hanging various attachments such as shutters, downspouts, fixtures, etc., always insert proper-sized pipe sleeves first. Then insert the nails or screws through them and seal sleeve openings with sealant.

**Fig. 1)** Insert sleeve so that it holds shutter 1/2" from face of system. Caulk between sleeve and system. Fill sleeve with sealant prior to inserting screw.

**Fig. 2)** Install sleeve flush with face of system. Apply sealant around and inside the sleeve prior to inserting nail or screw.



**FIG. 2**

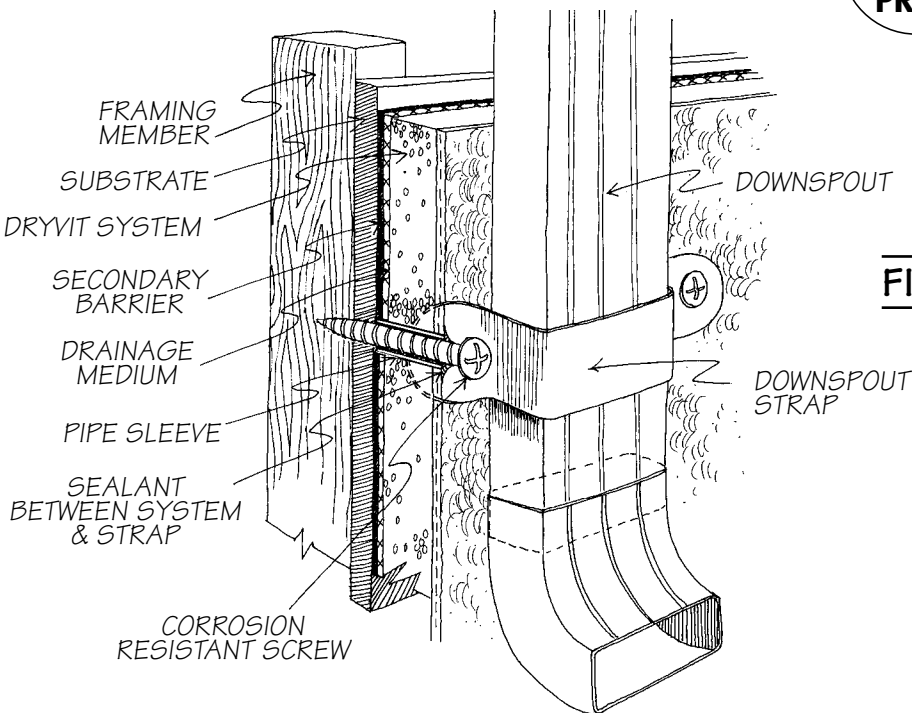

### SUCCESSFUL BUILDERS SHARE THEIR KNOWLEDGE

All good builders know how important it is to pay attention to details. In this series, Dryvit focuses on key details that successful builders follow when installing exterior insulation and finish systems. Use these drawings, along with Dryvit's complete system specifications and details, as a helpful guide for you and your subcontractors in planning and coordinating the critical interfaces between exterior building components.

### DRYVIT'S TECHNICAL SUPPORT IS TOPS

Throughout North America, we have a field service staff to assist with technical issues. Our corporate engineering staff is prepared to review your Dryvit plans, make suggestions and support your efforts. Total customer satisfaction is our goal. Use our 800 number and benefit from the Dryvit Difference.

### MAKE SURE IT'S A DRYVIT SYSTEM

We are the Number One EIFS manufacturer. We offer a number of exterior wall systems including Residential MD® and Sprint MD® Systems. You are off to a great start when you select a Dryvit system.

This detail is for general information and guidance only, and Dryvit disclaims any liability for the use of this detail and for the architecture, design, engineering or workmanship of any project.

For additional information, call 1-800-4-DRYVIT or visit [www.dryvit.com](http://www.dryvit.com)

©Dryvit Systems, Inc. 1997



An RPM Company

# Details Are The Key To Success

## GABLE END/SOFFIT SYSTEM END TERMINATIONS

FIG. 1

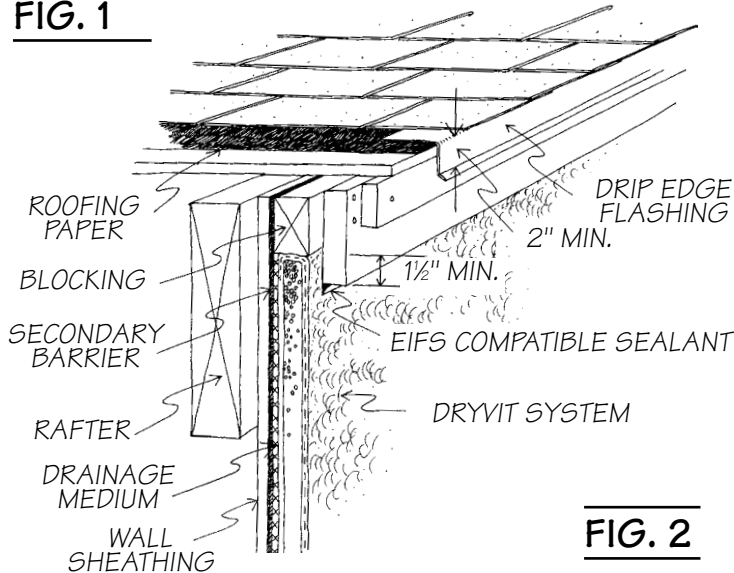

FIG. 2

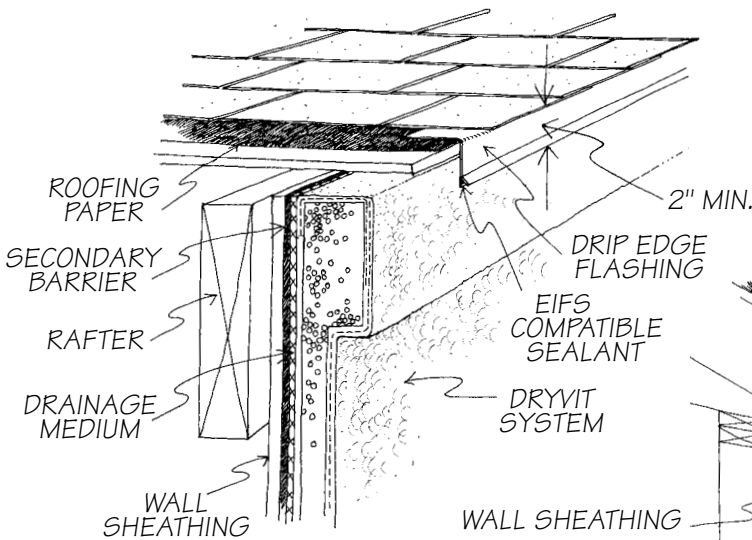
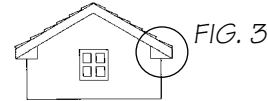
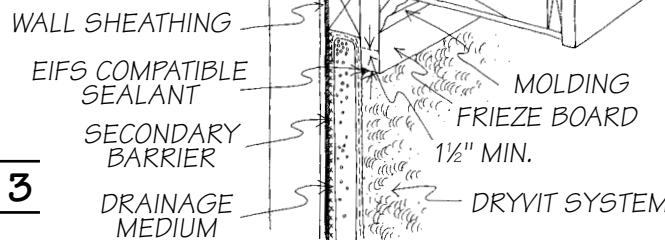

FIG. 3



**Fig. 1)** The Dryvit system and blocking are installed prior to the wood trim. The top edge of the Dryvit system shall be wrapped with reinforcing mesh and base coat. The wood trim overlaps the EIFS and is caulked along the bottom edge. The drip edge flashing should extend down at least 2".

**Fig. 2)** Install the Dryvit system encapsulating the top edge of the EPS insulation with base coat and reinforcing mesh. The drip edge flashing extends down a minimum of 2" and is caulked along the lower edge.

**Fig. 3)** Install the Dryvit system prior to the frieze board and trim. Wrap the top edge of the EPS with base coat and reinforcing mesh. The frieze board is fastened to the blocking. Caulk is applied along the bottom edge of the frieze board.

### SUCCESSFUL BUILDERS SHARE THEIR KNOWLEDGE

All good builders know how important it is to pay attention to details. In this series, Dryvit focuses on key details that successful builders follow when installing exterior insulation and finish systems. Use these drawings, along with Dryvit's complete system specifications and details, as a helpful guide for you and your subcontractors in planning and coordinating the critical interfaces between exterior building components.

### DRYVIT'S TECHNICAL SUPPORT IS TOPS

Throughout North America, we have a field service staff to assist with technical issues. Our corporate engineering staff is prepared to review your Dryvit plans, make suggestions and support your efforts. Total customer satisfaction is our goal. Use our 800 number and benefit from the Dryvit Difference.

### MAKE SURE IT'S A DRYVIT SYSTEM

We are the Number One EIFS manufacturer. We offer a number of exterior wall systems including Residential MD® and Sprint MD® Systems. You are off to a great start when you select a Dryvit system.



This detail is for general information and guidance only, and Dryvit disclaims any liability for the use of this detail and for the architecture, design, engineering or workmanship of any project.

For additional information, call 1-800-4-DRYVIT or visit [www.dryvit.com](http://www.dryvit.com)

©Dryvit Systems, Inc. 1997



An RPM Company

# Details Are The Key To Success

## SEALANT JOINTS WITH RESIDENTIAL SYSTEMS

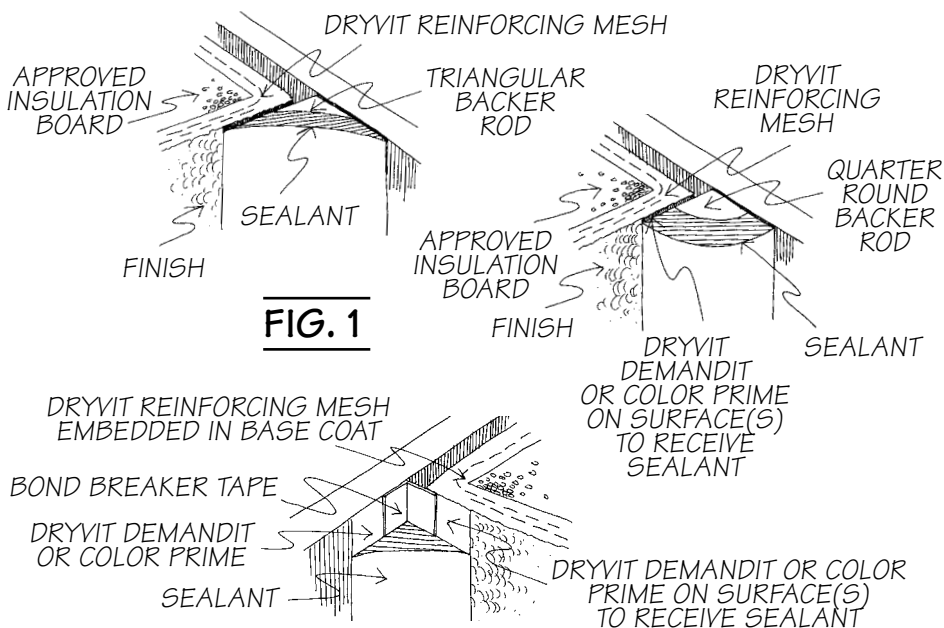

**Fig. 1)** Sealant performance is dependent on the width-to-depth ratio of the sealant. The rule of thumb is to apply the sealant half as deep as the joint width but not less than 1/4" nor over 1/2". Refer to specific sealant manufacturer's recommendations for variations. A closed cell backer rod is used to control the sealant depth and shape, provide a backing to tool against and to prevent 3-sided adhesion. Bond breaker tape may be installed in lieu of backer rod where appropriate.

**FIG. 2**

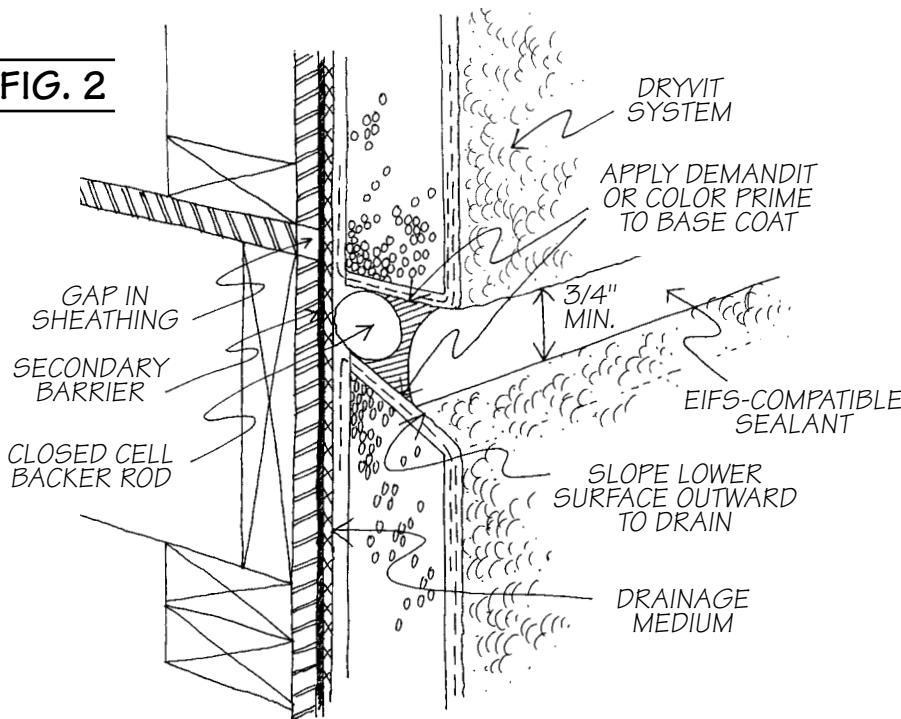

**Fig. 2)** The edges of the Dryvit system, which will receive sealant, must be wrapped with base coat and reinforcing mesh and coated with a smooth coating, such as Demandit® or Color Prime™. The textured finish should be stopped short of sealant. To ensure proper adhesion, the recommended sealant primer shall always be used. Refer to complete Dryvit details to determine what type of sealant joint is required at typical conditions.

### SUCCESSFUL BUILDERS SHARE THEIR KNOWLEDGE

All good builders know how important it is to pay attention to details. In this series, Dryvit focuses on key details that successful builders follow when installing exterior insulation and finish systems. Use these drawings, along with Dryvit's complete system specifications and details, as a helpful guide for you and your subcontractors in planning and coordinating the critical interfaces between exterior building components.

### DRYVIT'S TECHNICAL SUPPORT IS TOPS

Throughout North America, we have a field service staff to assist with technical issues. Our corporate engineering staff is prepared to review your Dryvit plans, make suggestions and support your efforts. Total customer satisfaction is our goal. Use our 800 number and benefit from the Dryvit Difference.

### MAKE SURE IT'S A DRYVIT SYSTEM

We are the Number One EIFS manufacturer. We offer a number of exterior wall systems including Residential MD® and Sprint MD® Systems. You are off to a great start when you select a Dryvit system.



This detail is for general information and guidance only, and Dryvit disclaims any liability for the use of this detail and for the architecture, design, engineering or workmanship of any project.

For additional information, call 1-800-4-DRYVIT or visit [www.dryvit.com](http://www.dryvit.com)



# Details Are The Key To Success

## WINDOW OPENINGS WITH RESIDENTIAL SYSTEMS

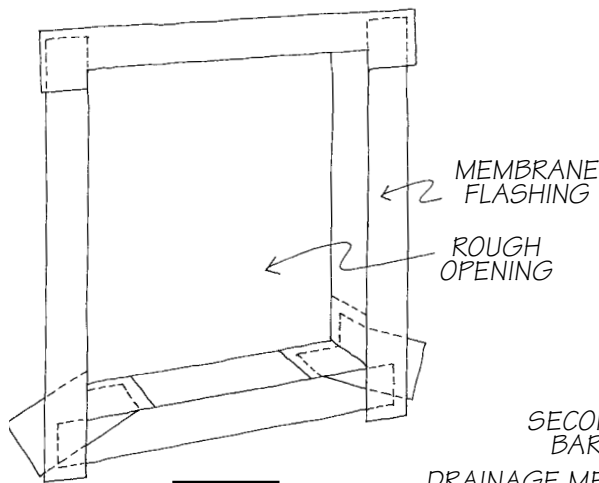
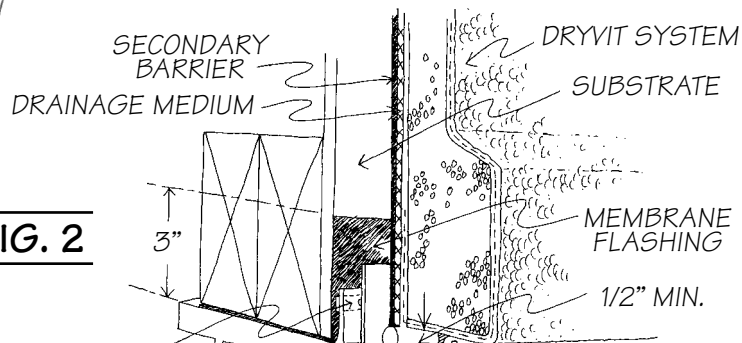

**FIG. 1**

**Fig. 1)** Prior to installing the window, wrap the rough opening with membrane flashing. The strips are applied in weather-board fashion with the head piece lapping over the jamb pieces, which lap over the sill piece.

**Fig. 2)** A bead of sealant is applied on the window flange; and the window is set into the opening, leveled and secured per manufacturer's instructions. The Dryvit system is then installed leaving a minimum 1/2" gap around the window to install sealant. Windows without integral flashing and ganged windows will need to have proper head flashing installed by field personnel.

**Fig. 3)** The tops of projecting EIFS sills shall be sloped a minimum of 3:12. The Dryvit system is held back from the window for proper sealant application.



**FIG. 2**

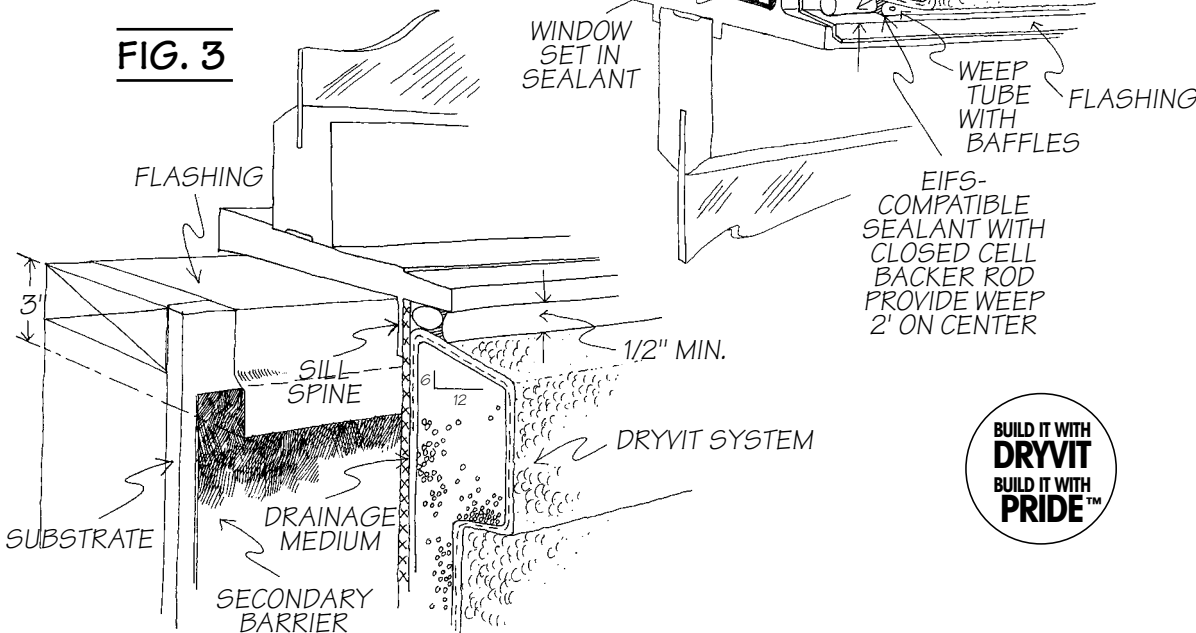

**FIG. 3**

### SUCCESSFUL BUILDERS SHARE THEIR KNOWLEDGE

All good builders know how important it is to pay attention to details. In this series, Dryvit focuses on key details that successful builders follow when installing exterior insulation and finish systems. Use these drawings, along with Dryvit's complete system specifications and details, as a helpful guide for you and your subcontractors in planning and coordinating the critical interfaces between exterior building components.

### DRYVIT'S TECHNICAL SUPPORT IS TOPS

Throughout North America, we have a field service staff to assist with technical issues. Our corporate engineering staff is prepared to review your Dryvit plans, make suggestions and support your efforts. Total customer satisfaction is our goal. Use our 800 number and benefit from the Dryvit Difference.

### MAKE SURE IT'S A DRYVIT SYSTEM

We are the Number One EIFS manufacturer. We offer a number of exterior wall systems including Residential MD® and Sprint MD® Systems. You are off to a great start when you select a Dryvit system.



This detail is for general information and guidance only, and Dryvit disclaims any liability for the use of this detail and for the architecture, design, engineering or workmanship of any project.

For additional information, call 1-800-4-DRYVIT or visit [www.dryvit.com](http://www.dryvit.com)



## **Dryvit...The Company**

As a leading manufacturer of EIF systems for over 30 years, Dryvit Systems, Inc. has provided products for hundreds of thousands of energy-efficient, durable and cost-effective walls for commercial and residential buildings nationwide.

Dryvit systems are recognized by the design and building community as the best engineered systems available - they offer design flexibility and a cost-competitive alternative to other cladding materials. Dryvit systems offered for the residential market include the Residential MD System® and the Sprint MD System®.

Dryvit's commitment to continued research and development, testing and training, compliance with national and local building codes and the strictest quality control in the EIFS industry ensure superior products unmatched in the building community. Also, every Dryvit manufacturing facility is certified to ISO 9001 standards, the worldwide common denominator of product consistency and excellence.

As quality conscious as Dryvit is, the ultimate success and performance of the Dryvit system - and, in truth, any exterior wall cladding - depends on the skill and knowledge of the contractor as well as the active involvement of the builder and other subcontractors.

## **DRYVIT RESIDENTIAL SYSTEMS**

### **Residential MD System**

The Dryvit Residential MD System® is engineered specifically for residential construction. It incorporates a specially designed drainage plane to allow incidental moisture to drain out of the wall at the base of the system. The Residential MD System is mechanically fastened to a plywood or OSB substrate. It offers a transferable 10-year moisture drainage and materials warranty.

### **RESIDENTIAL MD SYSTEM COMPONENTS**

- Drainage Medium
- Approved Mechanical Fasteners
- Expanded Polystyrene Insulation Board (R-value = 3.85 per inch)
- Reinforcing Mesh
- Dryvit Genesis® or Genesis DM™ Base Coat
- Dryvit 100% Acrylic-Based Dirt Pickup Resistant Finish



### **Sprint MD System**

The Dryvit Sprint MD System® was designed specifically for residential applications. In new construction, the insulation board is quickly attached by mechanical fasteners over a drainage plane, which allows for incidental moisture to drain harmlessly out of the wall at the base of the system. Sprint MD is also perfect for remodeling a home because the insulation board can be mechanically fastened to most types of siding found on older homes.

### **SPRINT MD SYSTEM COMPONENTS**

- Drainage Medium
- Approved Mechanical Fasteners
- Approved Polyisocyanurate Insulation Board (R-value = 5.6 per inch)
- Reinforcing Mesh
- Dryvit Genesis® or Genesis DM™ Base Coat
- Dryvit 100% Acrylic-Based Dirt Pickup Resistant Finish



## DESIGN OPTIONS

Each system permits three-dimensional detailing with the use of insulation board shapes.

### 15 KEYS TO SUCCESSFULLY BUILD OR REMODEL A HOME WITH DRYVIT

#### Review All Details With EIFS Contractor, Roofer and Framer.

- Ensure all wall components, including windows, meet building code requirements
- Expansion joints at each floor line
- System terminations are detailed per EIF System Installation Instructions
- Deck flashing properly installed
- Wall sheathing properly installed
- Proper installation of weather-resistant barrier
- Window and door heads properly flashed
- Proper caulking at windows, expansion joints, other openings
- Proper flashing where roof intersects wall
- Proper flashing at crickets and chimneys
- Frieze boards installed over the Dryvit system
- System is terminated above patios, decks, landings
- Insulation board is terminated a minimum of 200 mm (8") above grade
- Ambient temperature 4 °C (40 °F) and rising during installation and 24 hours thereafter
- Follow Dryvit's specifications, application instructions and details

Dryvit...striving to help you eliminate call-backs

We are available at **1-800-556-7752**

---

Dryvit Systems, Inc.  
One Energy Way  
P.O. Box 1014  
West Warwick, RI 02893  
800-556-7752  
www.dryvit.com

Information contained in this brochure conforms to the standard detail recommendations and specifications for the installation of Dryvit Systems, Inc. products as of the date of publication of this document and is presented in good faith. Dryvit Systems, Inc. assumes no liability, expressed or implied, as to the architecture, engineering or workmanship of any project. To ensure that you are using the latest, most complete information, contact Dryvit Systems, Inc.

