



PROPER USE OF TJI® FORM-I™ JOISTS

ATTENTION CONTRACTOR

Enclosed is **IMPORTANT** information on how to safely and properly use iLevel™ Trus Joist® TJI® Form-I™ joists as structural members in horizontal concrete formwork systems or scaffolding workdecks. Personal injury or death may result from failure to read and follow this information.

1 JOBSITE HANDLING

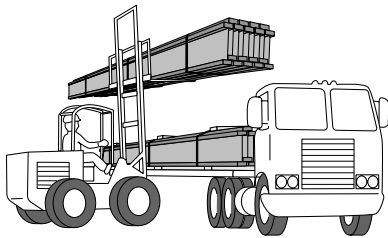

Use forklift to remove TJI® joists from truck.



DO NOT lift TJI® joists by top flange.



DO NOT lift TJI® joists in the flat orientation.

WARNING Workers should stay clear when cutting the banding to avoid possible injury from flying banding or toppling joists.

2 JOBSITE STORAGE

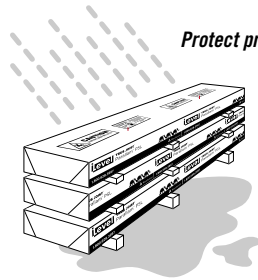

Protect products from sun and water.

Wrap is slippery when wet or icy.

Use support blocks at 10' on-center to keep products out of mud and water.

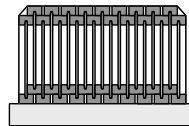

Store and handle joists in vertical orientation. Leave joists banded together until ready to install.

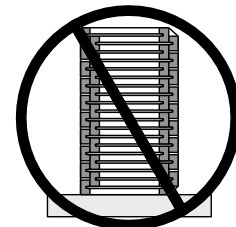

DO NOT store flat.

BUILD SAFELY

We at iLevel are committed to working safely and want to remind you to do the same.

We encourage you to follow the recommendations of OSHA (www.osha.gov) in the U.S. or provincial regulations (www.canoshweb.org/en/) in Canada regarding:

- Personal protective equipment (PPE) for hands, feet, head, and eyes
- Fall protection
- Use of pneumatic nailers and other hand tools
- Forklift safety

Please adhere to the iLevel product installation details, including the installation of safety bracing on unsheathed workdecks.

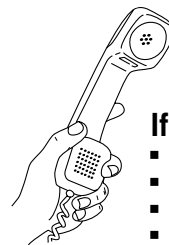

If You Have Problems

- Damaged iLevel products
- Improper fit
- Field modifications
- Questions about these drawings

Call your iLevel representative directly, or for general customer service call
1-877-856-9663

#COM-6610 COMMERCIAL INSTALLATION GUIDE

PROPER INSPECTION OF TJI® FORM-I™ JOISTS

The very nature of both scaffold workdeck and concrete forming applications requires that TJI® Form-I™ joists be exposed to hostile, repetitive-use environments. As a result, there are many ways in which a joist can be damaged or weakened, thereby reducing its ability to perform as intended.

All technical information provided in our product literature and design software assumes that the condition of the material being used is in new or like-new condition. To ensure acceptable performance, all joists should be properly inspected prior to each use. Any TJI® Form-I™ joists that may be damaged or weakened should be removed from service and evaluated for structural integrity by a qualified person before being used again.

Proper inspection of TJI® joists used in concrete forming or scaffolding applications should include—but not be limited to—looking for the common types of damage shown in the list at right:

- Web-to-flange separation
- Knifing of web through flange
- Holes in webs
- Split in flange
- Discoloration
- Soft spots in web or flange
- Mold/Fungus
- Taper cuts extending beyond inside face of support
- Notched flange
- Saw kerf in flange
- Buckling of web

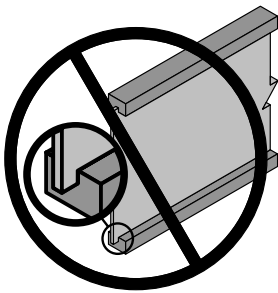

TJI® joists with flange-to-web separation should be cut back or removed from service.

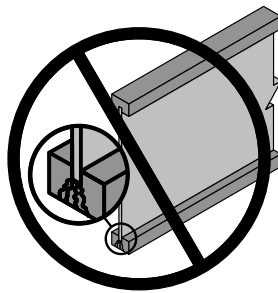

TJI® joists with the web knifing into a flange should be cut back or removed from service.

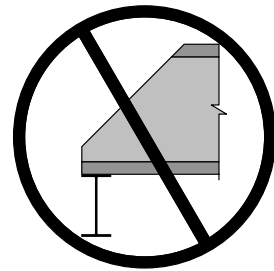

DO NOT bevel end of TJI® joist beyond inside face of support.

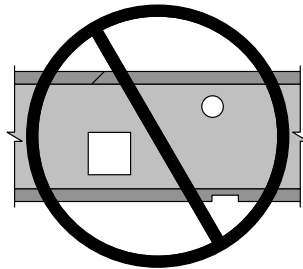

TJI® joists with holes in webs, or notches or saw kerfs in flanges should be cut back or removed from service.

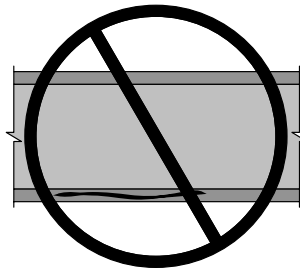

TJI® joists with splits in a flange should be cut back or removed from service.

INSPECTING CAMBER IN TJI® FORM-I™ JOISTS

Some TJI® Form-I™ joists are manufactured with camber. The table at the right shows the amount of initial camber typically found in a new joist. But this initial camber will be reduced after repeated use of the joist. It is important to occasionally inspect used TJI® Form-I™ joists to ensure that the remaining camber is adequate for satisfactory performance. To check the camber on

a joist, run a string lengthwise across the bottom flange, from end to end, and measure the distance from the string to the bottom of the joist at the centerline. TJI® Form-I™ joists that have reduced camber will deflect more than the amount indicated in iLevel load tables and software.

Initial Camber

Length	Camber
16'	5/32"
18'	7/32"
20'	1/4"
22'	5/16"
24'	3/8"
26'	7/16"
28'	1/2"
30'	19/32"

FLANGE NAILING

Top of Flange

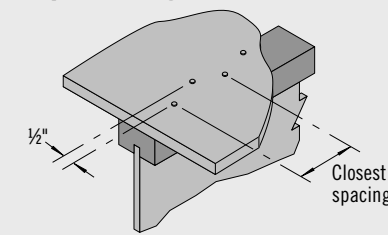

IMPORTANT
Nailing closer than specified may cause the flange to split.

Nailing pattern to be per plans and specifications. In addition, nail spacing must not be closer than the criteria listed below.

Nailing of Sheathing to TJI® Joist Flange(1)

Nail Type	Nail Diameter	Closest On-Center Spacing Per Row(3)
8d (2½") ⁽²⁾	Box	.113"
	Common	.131"
10d (3")	Box	.128"
	Common	.148"
12d (3¼")	Box	.128"
	Common	.148"
16d (3½")	Box	.135"
	Common	.162"

- Sheathing must be nailed to the full length of the top flange on the TJI® joist with a maximum nail spacing of 24" on-center.
- 14-gauge staples may be a direct substitute for 8d (2½") nails if a minimum penetration of 1" into the flange is maintained.
- If more than one row of nails is used, the rows must be offset at least ½" and staggered.

WEB STIFFENERS

If web stiffeners are required, follow the procedures below

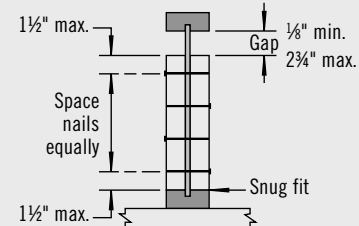

Web stiffener requirements will vary based on joist series and depth; they are always required at bearing on joists 20" in depth or greater. See plan/details for requirements specific to the joists being used on this project.

Web stiffeners for L65 joists must be 1" x 2 5/16" sheathing (with face grain vertical) that meets the requirements of PS1 or PS2, or CSA Standards Q151, Q325, or Q437. Web stiffeners for L90 and H90 joists shall be 2x4 material of construction grade or better.

Nailing Quantities for Web Stiffener Attachment

TJI® Joist Depth	L65		L90, H90	
	8d (2½") Nails	16d (3½") Nails	End	Intermediate
11 7/8"	3	3	3	3
14"	5	3	3	3
16"	6	4	4	4
18"	7	4	4	4
20"	8	5	5	5

When required, web stiffeners must be installed properly or the following problems may occur:

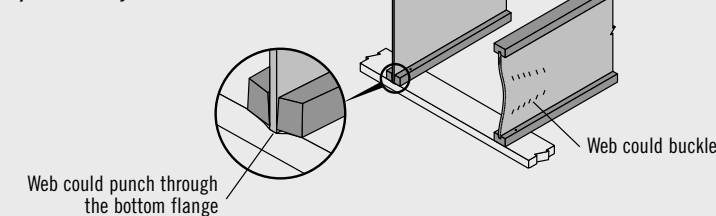

3 PANEL ASSEMBLY

Panel Assembly Procedures

- Layout TJI® joists at appropriate on-center spacing (per iLevel™ TJ-Beam® analysis).
- Attach 4x4 stickers and plywood skid guards to bottom flanges of the TJI® joists.
- Attach panel bolt assembly to the mid-span of the two center joists (see **Panel Bolt Assembly** detail).
- Place 3/8" sheathing to ends of TJI® joists.
- Place plyform sheets so that the edge of the sheathing aligns over the center of the top flange on the first joist.
- Attach plyform sheets to top flange of the TJI® joists.
- Attach a 2x4 to the cantilevered edge of the plyform sheets. (The 2x4 may be used to align adjacent panels during panel placement by locating the 2x4 a distance from the plyform edge that is equal to half the width of the TJI® joist flange.)

EXPLODED VIEW

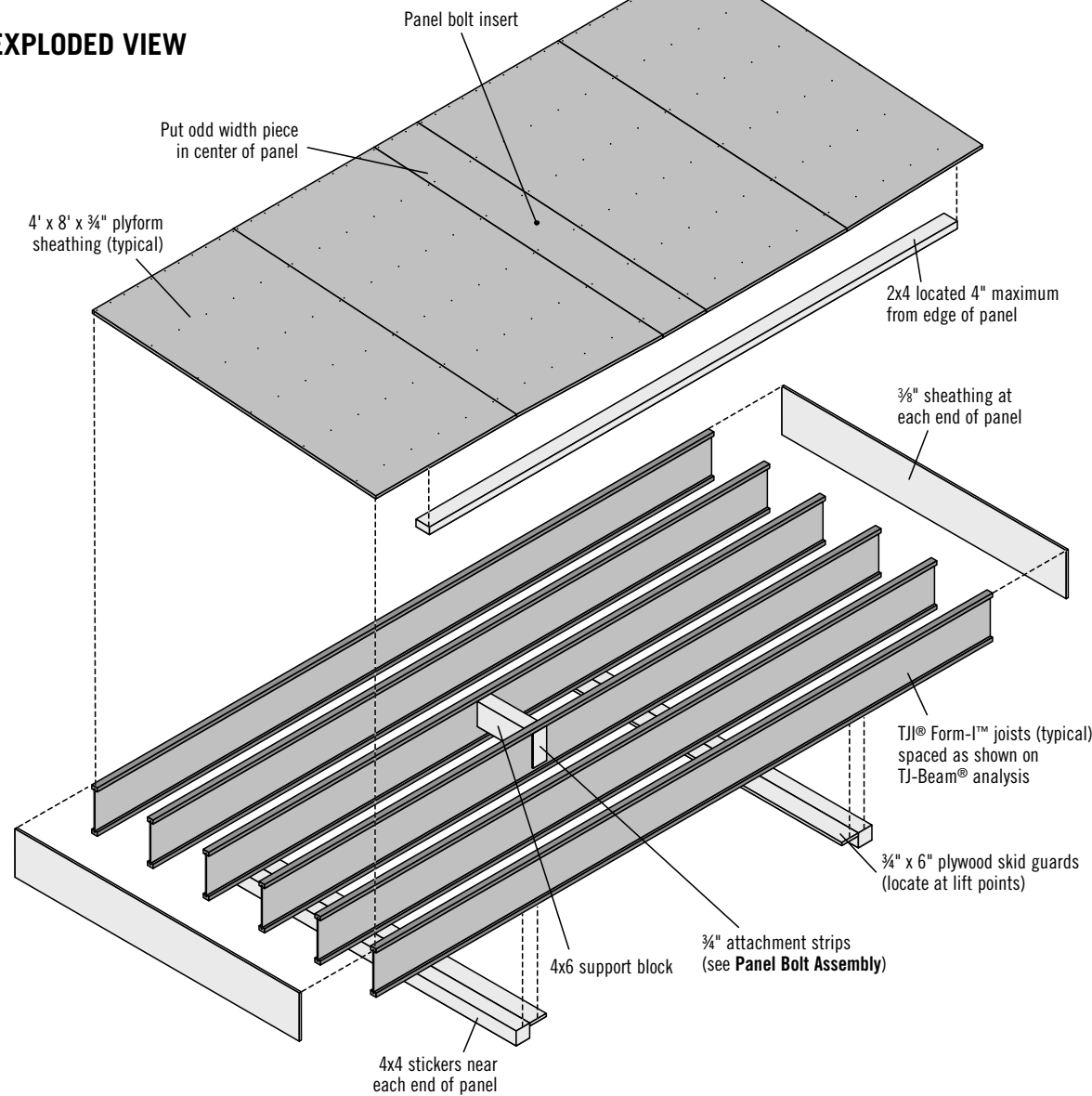

PANEL BOLT ASSEMBLY

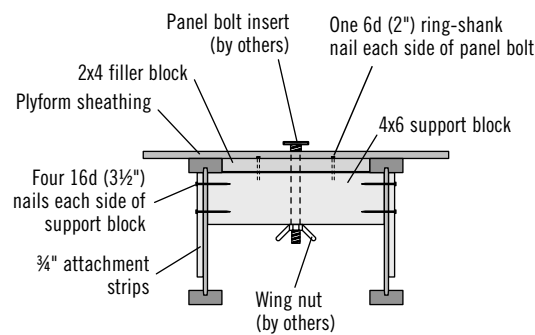

TJI® BLOCKING AT INTERMEDIATE SUPPORT

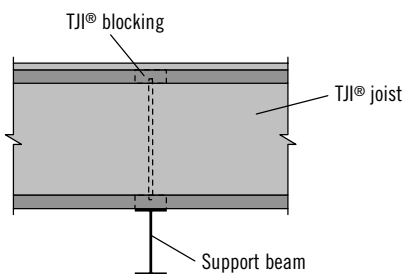

PLYWOOD RIM AT END SUPPORT

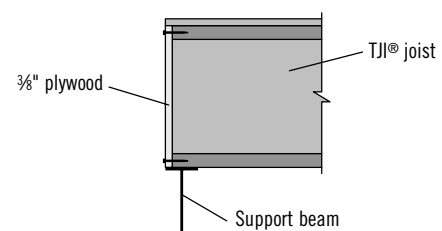

ASSEMBLED VIEW

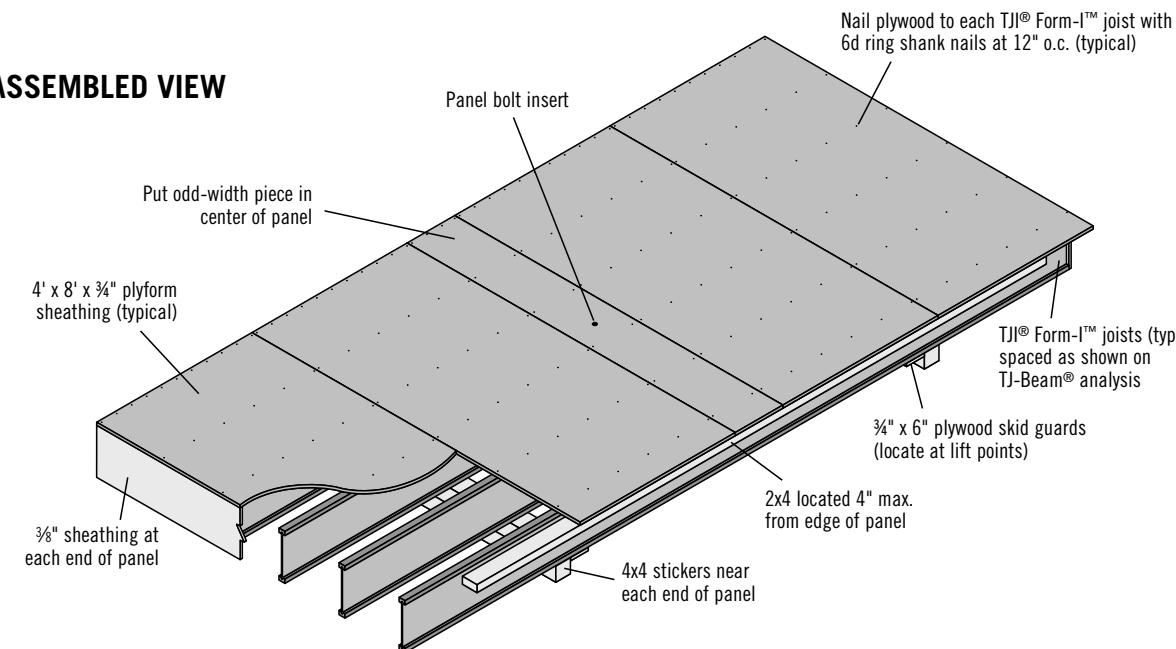

Fastener Table

Connection	Fastener Type / Description	Spacing / Quantity
Plyform sheathing to top flange of TJI® joists	6d ring-shank nail or 2" deck screw	24" on-center maximum
3/8" sheathing to ends of TJI® joist flanges	6d ring-shank nail	1 per flange
Bottom flange of TJI® joist to 4x4 sticker	16d ring-shank nail or 2" deck screw	1 per flange at each location
Bottom flange of TJI® joist to skid guard	6d ring-shank nail or 2" deck screw	2 per flange at each location
2x4 filler block to 4x6 support block	6d ring-shank nail	1 each side of insert
Plywood attachment strip to 4x6 support block	16d ring-shank nail	4 per side of support block
2x4 at panel edge to plyform sheathing	6d ring-shank nail or 2" deck screw	24" on-center maximum

HANDLING AND PLACING PANELS

Panels may be moved individually or in stacks (of up to 4), as required, by either a forklift or crane. When moving panels with a forklift, the forks should be located directly underneath the skid guards to prevent forks from stabbing joists. During panel placement, verify that supports are located as shown in the formwork design. Do not provide intermediate supports underneath panels—even temporarily—except in those locations designed for supports. If supports are placed beneath joists at mid-spans without proper detailing, they may cause lateral instability or prevent the joist deflection required with cambered TJI® joists. Verify that the panel bolt insert is securely in place prior to pouring concrete.

STRIPPING PANELS

Do not begin stripping formwork until concrete has gained adequate strength, as determined by project engineer or formwork designer. Care should be taken when stripping panels to prevent damage to TJI® joists, sheathing, or other components. Proper use of a form release agent will make stripping of panels easier and will help prevent damage during the stripping process. Verify that the panel bolt assembly is in place and that the wing nut is properly secured before beginning to strip the form or remove the shores. To begin the stripping process, shores may be removed. Break the suction to the panels at corners. Once the panel is fully freed from the concrete slab and ready to be moved, use a forklift to position stripping trusses beneath the panel. The stripping trusses should align directly under the skid guards to protect the joists. With stripping trusses in place, the deck bolt may be unthreaded and the panel lowered and moved.



DO NOT pry downward on bottom flange of TJI® joists when stripping panels.

Use a form release agent to make panels easier to strip and prevent damage.

4 SCAFFOLD WORKDECK ASSEMBLY

IMPORTANT

Safety bracing must extend to braced end wall, beam, or sheathing
Place safety bracing (1x4 minimum)

- 8' on-center for L65 joists
 - 10' on-center for L90 and H90 joists
- Safety bracing is required at all bearing locations where joists are not otherwise braced

4' (minimum) strip of sheathing (temporary or permanent) if there is no braced end wall. If permanent, fasten per plans and specifications. If temporary, use 8d (2½") form nails at 12" on-center.

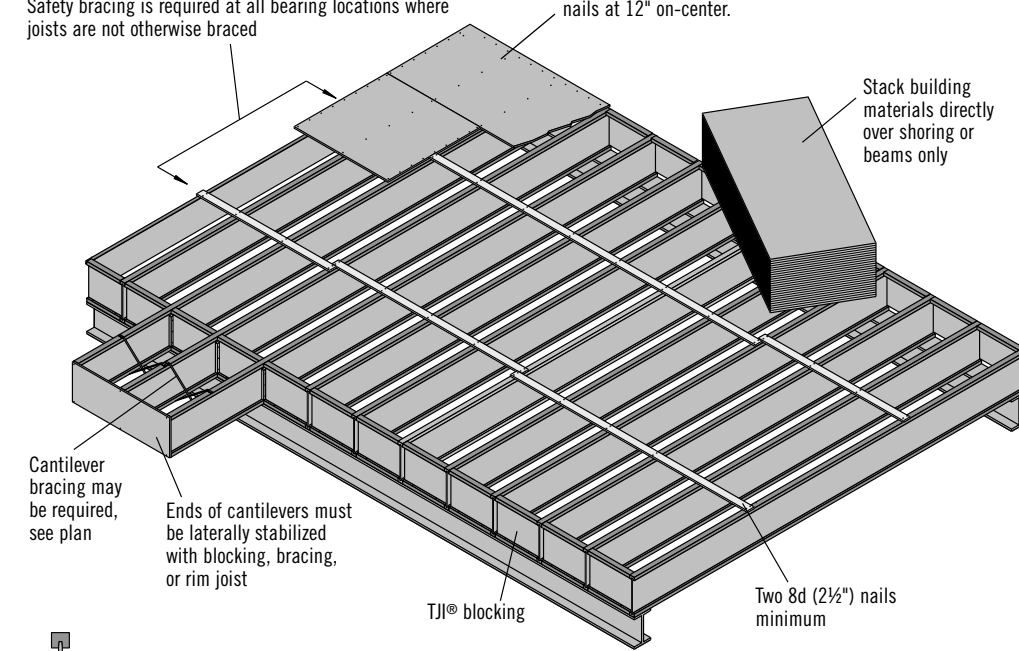

Minimum attachment: One 10d (3") box nail each side of TJI® joist at bearing, 1½" minimum from end to minimize splitting



DO NOT stack building materials on unshathed joists. Stack only over beams or walls.



DO NOT allow workers to walk on joists when lying flat.

WARNING

Without correctly installed installation bracing as shown above, joists can buckle sideways or roll over, causing death or serious personal injury and property damage.

NOTICE

Installation bracing and procedures, as well as the safety of workers, are the responsibility of the installer. The installer should make sure that this installation information is understood by all persons involved in the joist installation.

WARNING

- All blocking, hangers, rim boards, and rim joists at the end supports of the TJI® joists must be completely installed and properly nailed.
- TJI® joist flanges must remain straight within a tolerance of ½" from true alignment.
- Sheathing must be completely to each TJI® joist before additional loads can be placed on the system.
- Without bracing, buckling sideways or rollover is highly probable under light construction loads such as a worker or stacked sheathing.

HORIZONTAL SHORING BEAM SAFETY RULES

As Recommended by the Scaffolding, Shoring and Forming Institute, Inc.

It shall be the responsibility of all employers and users to read and comply with the following common sense guidelines which are designed to promote safety in the erection, dismantling and use of horizontal shoring beams. These guidelines are not all inclusive nor do they supplant or replace other additional safety and precautionary measures to cover usual or unusual conditions. If these guidelines conflict in any way with any state, provincial, local or federal statute or governmental regulation, said statute or regulation shall supersede these guidelines and it shall be the responsibility of each employee and user to comply therewith and also to be knowledgeable and understand all state, local or federal statutes or governmental regulations pertaining to horizontal shoring beams.

A. GENERAL GUIDELINES

1. POST THESE SHORING SAFETY GUIDELINES in a conspicuous place and be sure that all persons who erect, dismantle or use shoring are aware of them.
2. FOLLOW ALL STATE, PROVINCIAL, LOCAL AND FEDERAL CODES, ORDINANCES AND REGULATIONS pertaining to shoring.
3. SURVEY THE JOBSITE. A survey by a qualified person shall be made of the jobsite for hazards, such as untamped earth fills, ditches, debris, high tension wires, unguarded openings and other hazardous conditions. These conditions should be corrected or avoided as noted in the following sections.
4. PLAN SHORING ERECTION SEQUENCE in advance and obtain necessary access equipment to accomplish the work safely.
5. INSPECT ALL EQUIPMENT BEFORE USING. Never use any equipment that is structurally defective in any way. Mark it or tag it as defective, then remove it from the jobsite.
6. A SHORING DRAWING prepared by a person qualified to analyze the loading intended and consistent with the manufacturer's recommended safe working loads, shall be used on the job at all times.
7. ERECT, DISMANTLE OR ALTER SHORING only under the supervision of a qualified person.
8. DO NOT ABUSE OR MISUSE THE SHORING EQUIPMENT.
9. INSPECT ERECTED SHORING:
 - (a) immediately prior to concrete placement;
 - (b) during concrete placement and while vibrating concrete, and
 - (c) after concrete placement until concrete is set.
10. NEVER TAKE CHANCES! IF IN DOUBT REGARDING THE SAFETY OR USE OF THE SHORING, CONSULT YOUR SHORING SUPPLIER.
11. USE SHORING EQUIPMENT only for the purposes or in ways for which it was intended. Use proper tools when installing equipment.
12. ERECTING AND DISMANTLING OF SHORING requires good physical condition. Do not work on shoring if you feel dizzy, unsteady in any way or are impaired in any way by drugs or any other substances.
13. DO NOT USE SHORING SYSTEMS for fall protection.

B. USE MANUFACTURER'S RECOMMENDED SAFE WORKING LOADS AND PROCEDURES FOR:

1. Span, spacing, and types of shoring beams.
2. Types, sizes, heights, and spacing of vertical shoring supports.

C. USE LUMBER EQUIVALENT TO THE STRESS, species, grade and size used on the layout. Use only lumber that is in good condition. Do not splice between supports.

D. DO NOT MAKE UNAUTHORIZED CHANGES OR SUBSTITUTION OF EQUIPMENT; always consult your supplier prior to making changes necessitated by jobsite conditions.

E. PROVIDE AND MAINTAIN ADEQUATE SUPPORT to properly distribute shoring loads. When supporting horizontal shoring beams on:

1. masonry walls, insure that masonry units have adequate strength. Brace walls as necessary.
2. ledgers supported by walls using bolts, or other means, they should be properly designed and installed per recommendation of supplier or job architect/engineer.

3. formwork, such formwork should be designed for additional loads imposed by the shoring beams.
4. structural steel framework, the ability of the steel to support this construction loading should be checked and approved by the responsible project architect/engineer.
5. When supporting horizontal beams on steel hangers, be sure that the bearing ends fully engage on the hangers. The hangers shall be designed to conform to the bearing end and shall have a rated strength to safely support the shoring loads imposed. (Follow hanger manufacturers' recommendations.)
6. Do not bear adjustable horizontal beams on other adjustable horizontal beams.

F. SPECIAL CONSIDERATION MUST BE GIVEN TO THE INSTALLATION OF HORIZONTAL SHORING:

1. When sloped or supported by sloping ledgers (stringers).
2. When ledger (stringer), including blocking height/width ratio exceeds 2½ to 1. Under no circumstances shall horizontal shoring beams bear on a single "two by" ledger (stringer).
3. When eccentric loading conditions exist.
4. When ledger (stringer) consists of multiple members. (i.e., double 2x6, 2x8, etc.)

G. ASSURE THAT BEARING ENDS OF SHORING BEAMS ARE PROPERLY SUPPORTED and that locking devices are properly engaged before placing any load on beams.

H. IF MOTORIZED CONCRETE PLACEMENT EQUIPMENT IS TO BE USED, be sure that lateral and other forces have been considered and adequate precautions taken to assure stability.

I. HORIZONTAL SHORING BEAMS SHOULD NOT be supported other than at the bearing prongs unless recommended by supplier.

J. DO NOT NAIL BEAM BEARING PRONGS TO LEDGER.

K. PLAN CONCRETE POURING METHODS AND SEQUENCES TO insure against unbalanced loading of the shoring equipment. Take all necessary precautions to avoid uplift of shoring components and formwork.

L. AVOID SHOCK OR IMPACT LOADS FOR which the shoring was not designed.

M. DO NOT PLACE ADDITIONAL, TEMPORARY LOADS (such as rebar bundles) on erected formwork or poured slabs, without checking the capacity of the shoring and/or structure to safely support such additional loads.

N. DO NOT RELEASE ANY PART OF THE FORMWORK OR SHORING until proper authority has been obtained. Particular consideration must be given to reshoring procedures.

O. WIND LOAD: Erector must analyze the forming/shoring system for additional loads imposed from wind loading and provide adequate anchorage to resist these forces, including uplifting wind forces.

P. RESHORING is one of the most critical operation in formwork; consequently, reshoring procedure must be designed by a qualified person and approved by the architect/engineer of record.

REPRINTED WITH PERMISSION FROM SCAFFOLDING, SHORING AND FORMING INSTITUTE, INC.

September 2006
Reorder COM-6610

This document supersedes all previous versions. If this is more than one year old, contact your dealer or iLevel rep.
JM

 Weyerhaeuser®, TJ-Beam®, TJI®, and Trus Joist® are registered trademarks and Form-1™ and iLevel™ are trademarks of Weyerhaeuser Company. © 2006 Weyerhaeuser Company. All rights reserved. Printed in the USA on Weyerhaeuser Cougar® Opaque.