



WALL SYSTEMS SUBMITTAL

A Submittal Guide for Acoustical Ceilings, Exterior Sheathing, Exterior and Interior Framing

TABLE OF CONTENTS

American Made 3

LEED Credits 4

Acoustical Ceiling 5

 Pin and Clip Assemblies 5

 Spring Steel 7

Exterior Sheathing 8

 GypFast 8

Exterior Framing 16

 Perimeter Track 16

 Steel 17

Interior Framing 18

 Concrete 18, 19

 Steel 18, 20

 Sound Caulk 21

 Sound Spray 22

MADE IN AMERICA
Ramset[®]

The American Recovery and Reinvestment Act of 2009 requires that all construction materials for federal, state and local stimulus projects must be manufactured in the United States.

Ramset is unique in the world of construction tools, fasteners and sealant manufacturing. Overall, 98% of Ramset fasteners and accessories are made in the USA.

Unlike our competitors you know you are buying American made products and supporting the American economy and workers when you buy Ramset. Ramset's parent company, Illinois Tool Works (NYSE: ITW) employees more than 25,000 Americans.



Manufacturer	Tools	Fasteners
Ramset Tools: TrakFast GypFast T3SS T3Mag Rocket Rocketmag D45A	Glendale Heights, IL Glendale Heights, IL Glendale Heights, IL Glendale Heights, IL Glendale Heights, IL Glendale Heights, IL Glendale Heights, IL	Paris, KY Paris, KY Paris, KY Paris, KY Paris, KY Paris, KY Paris, KY
Hilti Powers Tyrex Simpson	Austria Japan/ China Taiwan China	Liechtenstein/ China China China China
Ramset Manufacturing: Powder Loads Manufacturing Gas Fuel Cells Production Sealant Manufacturing Spring Steel Manufacturing Wedge Anchors and LDT Anchors Manufacturing Tapcon Manufacturing EZ Anchor Manufacturing		St Louis, MO Pontotoc, MS Rockland, MA Addison, IL Michigan City, IN Itasca, IL Elk Grove Village, IL



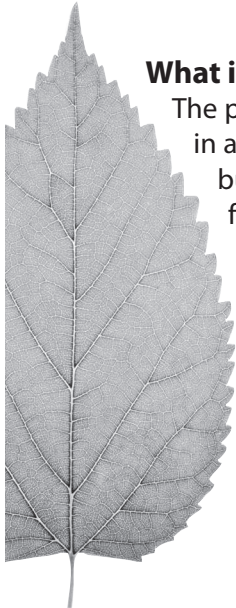

What is LEED

The purpose of Leadership in Energy and Environmental Design (LEED) is to construct buildings in an energy efficient manner and reduce the buildings' energy consumption. As a result, these buildings can help conserve non-renewable energy resources; decrease dependence on foreign oil; and lower greenhouse gas emissions.

Ramset LEED Credit EQ 4.1

EQ 4.1 was developed with the intent to reduce the quality of indoor air contaminants that are odorous, irritating, and/or harmful to the comfort and well being of installers and occupants.

Ramset's SC200 sound control sealant meets LEED EQ credit 4.1 for low emitting VOC materials and earns 1 LEED point.

Ramset LEED Credit MR 5.1

MR 5.1 was developed with the intent to increase demand for building materials and products that are extracted and manufactured within the region, thereby supporting the use of indigenous resources and reducing the environmental impact resulting from transportation.

Ramset's pins, sealants, spring steel products, electrical accessories and anchors may meet the requirements for LEED MR 5.1 if your project falls within 500 miles of our manufacturing facilities.

How to calculate LEED MR 5.1

LEED MR Credit 5.1 is calculated on a 500 mile radius from/to distribution points. Use Google Maps to calculate the distance to your project from:

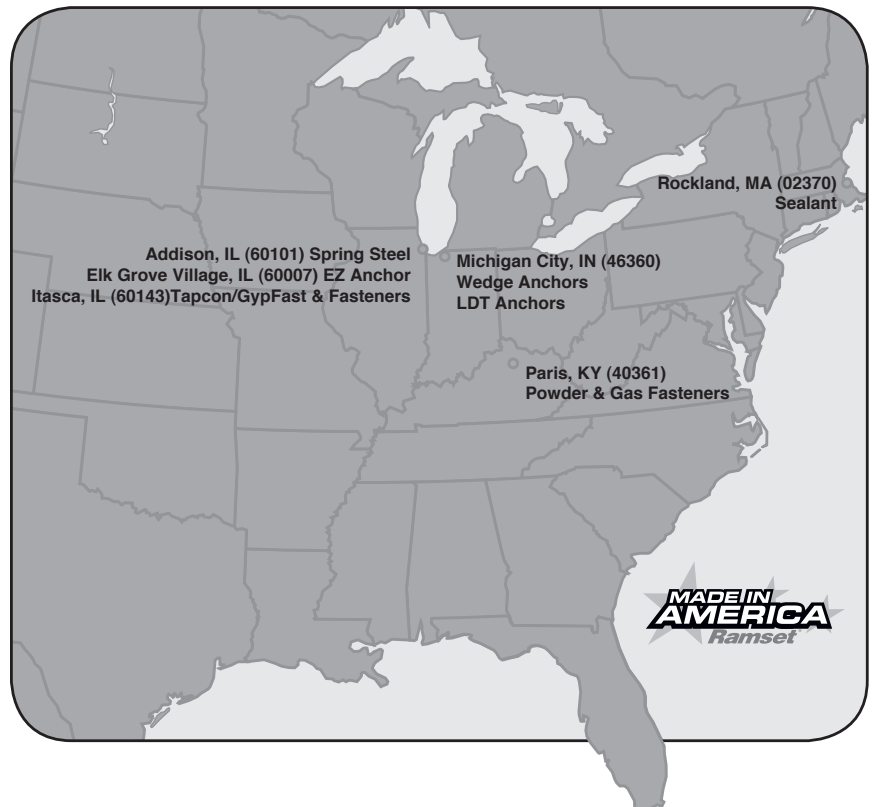

Location	Zip Code	Product
Addison, IL	60101	Spring Steel
Elk Grove Village, IL	60007	EZ Anchor
Itasca, IL	60143	Tapcon/GypFast & Fasteners
Michigan City, IN	46360	Wedge & LDT Anchors
Rockland, MA	02370	Sealant
Paris, KY	40361	Powder & Gas Fasteners

CEILING CLIP ASSEMBLIES



Standard Powder Clip Assemblies

ANGLE CLIP IN CONCRETE

PART NUMBER SERIES	SHANK DIAMETER (INCH)	MINIMUM PENETRATION (INCH)	INSTALLED IN STONE AGGREGATE CONCRETE – CONCRETE COMPRESSIVE STRENGTH					
			ALLOWABLE LOAD – <i>Ultimate Load</i>					
			4000 PSI					
			TENSION (LBS)	SHEAR (LBS)	OBLIQUE (LBS)			
SDC100 / SDC125	0.145	7/8	115 <i>575</i>	120 <i>1014</i>	145 <i>726</i>			
SDC125	0.145	1-1/8	130 <i>744</i>	167 <i>1090</i>	205 <i>1032</i>			

PART NUMBER SERIES	SHANK DIAMETER (INCH)	MINIMUM PENETRATION (INCH)	ALLOWABLE WORKING VALUES – INSTALLED IN 3000 PSI LIGHTWEIGHT CONCRETE					
			ALLOWABLE LOAD – <i>Ultimate Load</i>					
			3000 PSI LIGHTWEIGHT WITH METAL DECKING					
			LOWER FLUTE TENSION (LBS)	LOWER FLUTE SHEAR (LBS)	LOWER FLUTE OBLIQUE (LBS)	UPPER FLUTE TENSION (LBS)	UPPER FLUTE SHEAR (LBS)	
SDC100	0.145	7/8	67 <i>335</i>	237 <i>1186</i>	90 <i>448</i>	104 <i>571</i>	310 <i>1678</i>	
SDC125	0.145	1-1/8	94 <i>471</i>	276 <i>1378</i>	119 <i>596</i>	106 <i>528</i>	319 <i>1597</i>	

Note 1: ALLOWABLE loads are shown in the **LARGE BOLD** font, *Ultimate* loads are shown in *smaller italic* font. **Note 2:** Testing conducted in accordance with ICC AC70 & ASTM E1190. **Note 3:** Safety factors are based on coefficient of variation. In accordance with ICC AC70, the safety factor will be no less than 5. **Note 4:** Values shown in concrete are for the clip assembly only. Connected members must be investigated separately. **Note 5:** Cyclic, fatigue, shock loads, and other design criteria may require a different safety factor. **Note 6:** Job site testing may be required to determine actual job site values. **Note 7:** Minimum edge distance is 3 inches unless otherwise approved. **Note 8:** For SI: 1 lbf = 4.448 N, 1 inch = 25.4 mm, 1 ksi = 6.89MPa. Tables converted to metric are available on our website.

Power Point Powder Clip Assemblies —

Designed for difficult overhead applications



ANGLE CLIP IN CONCRETE

PART NUMBER SERIES	SHANK DIAMETER (INCH)	MINIMUM PENETRATION (INCH)	INSTALLED IN STONE AGGREGATE CONCRETE – CONCRETE COMPRESSIVE STRENGTH					
			ALLOWABLE LOAD – <i>Ultimate Load</i>					
			4000 PSI			6000 PSI		
			TENSION (LBS)	SHEAR (LBS)	OBLIQUE (LBS)	TENSION (LBS)	SHEAR (LBS)	OBLIQUE (LBS)
SPC78	0.150	3/4	155 <i>897</i>	188 <i>1050</i>	-----	150 <i>788</i>	153 <i>949</i>	140 <i>769</i>
SPC114	.150/.180	1-1/8	127 <i>811</i>	226 <i>1130</i>	181 <i>904</i>	169 <i>853</i>	300 <i>1500</i>	223 <i>1114</i>

PART NUMBER SERIES	SHANK DIAMETER (INCH)	MINIMUM PENETRATION (INCH)	ALLOWABLE WORKING VALUES – INSTALLED IN 3000 PSI LIGHTWEIGHT CONCRETE					
			ALLOWABLE LOAD – <i>Ultimate Load</i>					
			3000 PSI LIGHTWEIGHT WITH METAL DECKING					
			LOWER FLUTE TENSION (LBS)	LOWER FLUTE SHEAR (LBS)	LOWER FLUTE OBLIQUE (LBS)	UPPER FLUTE TENSION (LBS)	UPPER FLUTE SHEAR (LBS)	
SPC78	0.150	3/4	59 <i>293</i>	202 <i>1109</i>	65 <i>323</i>	84 <i>419</i>	324 <i>1622</i>	
SPC114	150/.180	1-1/8	157 <i>786</i>	272 <i>1358</i>	153 <i>766</i>	180 <i>899</i>	334 <i>1673</i>	

Note 1: ALLOWABLE loads are shown in the **LARGE BOLD** font, *Ultimate* loads are shown in *smaller italic* font. **Note 2:** Testing conducted in accordance with ICC AC70 & ASTM E1190. **Note 3:** Safety factors are based on coefficient of variation. In accordance with ICC AC70, the safety factor will be no less than 5. **Note 4:** Values shown in concrete are for the clip assembly only. Connected members must be investigated separately. **Note 5:** Cyclic, fatigue, shock loads, and other design criteria may require a different safety factor. **Note 6:** Job site testing may be required to determine actual job site values. **Note 7:** Minimum edge distance is 3 inches unless otherwise approved. **Note 8:** For SI: 1 lbf = 4.448 N, 1 inch = 25.4 mm, 1 ksi = 6.89MPa. Tables converted to metric are available on our website.

CEILING CLIP ASSEMBLIES

Gas Clip Assembly —

Designed for projects where use of powder is not permissible



FASTENERS IN CONCRETE

FASTENER PART NUMBER	SHANK DIA. (INCH)	MINIMUM PENETRATION (INCH)	INSTALLED IN STONE AGGREGATE CONCRETE CONCRETE COMPRESSIVE STRENGTH ALLOWABLE LOAD – <i>Ultimate Load</i>						HOLLOW BLOCK Grade N, Type 1	
			4000 PSI		6000 PSI		3000 PSI Lightweight LOWER FLUTE		FACE SHELL Min 1-1/4" face thickness	
			TENSION (LBS)	SHEAR (LBS)	TENSION (LBS)	SHEAR (LBS)	TENSION (LBS)	SHEAR (LBS)	TENSION (LBS)	SHEAR (LBS)
34CLIP	0.104/.125	5/8	62 <i>310</i>	----	106 <i>528</i>	----	44 <i>220</i>	----	----	----

* ESR-1955 pin data applies. **Note 1:** ALLOWABLE loads are shown in the **LARGE BOLD** font, *Ultimate* loads are shown in *smaller italic* font. **Note 2:** Testing conducted in accordance with ICC AC70 & ASTM E1190
Note 3: Safety factors are based on coefficient of variation. In accordance with ICC AC70, the safety factor will be no less than 5. **Note 4:** Values shown in concrete are for fastener only. Connected members must be investigated separately. **Note 5:** Cyclic, fatigue, shock loads and other design criteria may require a different safety factor. **Note 6:** Job-site testing may be required to determine actual job site values.
Note 7: Minimum edge distance is 3 inches unless otherwise approved. In hollow block applications, no more than one fastener per cell. **Note 8:** For SI: 1 lbf = 4.448 N, 1 inch = 25.4 mm, 1 ksi = 6.89MPa.
 Tables converted to metric are available on our website.

STEEL CLIP ASSEMBLIES

Purlin Clips —

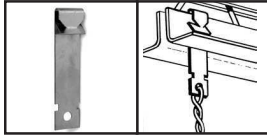

L1701 (J-CLIP)

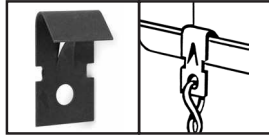

L1801 (CLIP-PUR)

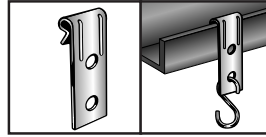

FH116 / FH532

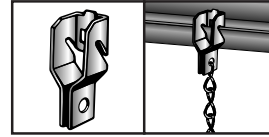



PH

PART NUMBER	DESCRIPTION	ALLOWABLE LOAD
L1701 (J-CLIP)	1/16" TO 1/4" FOR VERTICAL FLANGE	252 LBS
L1801 (CLIP-PUR)	1/16" TO 1/4" ANGLED Z-PURLIN	217 LBS
FH116	1/16" TO 5/16" VERTICAL FLANGE	160 LBS (STATIC)
FH532	5/32" TO 1/4" VERTICAL FLANGE	160 LBS (STATIC)
PH	Z-PURLIN WITH 1/4" BOTTOM HOLE	100 LBS (STATIC)

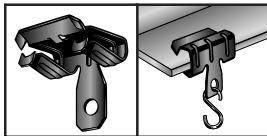
Beam Clamps —



SFC18

PART NUMBER	DESCRIPTION	ALLOWABLE (STATIC) LOAD
SFC18	1/8" TO 1/4" FLANGE BEAM CLAMP 	200 LBS
SFC516	5/16" TO 1/2" FLANGE BEAM CLAMP 	200 LBS
SFC916	9/16" TO 3/4" FLANGE BEAM CLAMP 	200 LBS

GYPFAST

Fastening Systems for Attachment of Sheathing to Light Gauge Steel Framing

Approvals, Listings and Testing

- 1) Georgia Pacific Dens-Glass Gold[®] Recognition Letter (Attached)
- 2) National Gypsum e²XP[®] Recognition Letter (Attached)
- 3) USG Securock[®] Evaluation Report (Attached)
- 4) CertainTeed GlasRoc[®] Recognition (Attached)
- 5) Nail Withdrawal/Tensile Tests- HardiPlank[®], Report #3051160 (Available)
- 6) Negative Wind Load Test Report # J20044629-231-02 (Available)
- 7) Withdrawal Test Report #3014672 (Available)
- 8) TekPin[®] Technical Values Data Report #3068232 (Available)
- 9) DensGlass Gold[®]-1/2" Pull Out Values R-1304 (Available)
- 10) UL Fire Resistance Ratings ANSI / UL263 BXUV.V458 (Available)
- 11) Gypsum Sheathing to Metal Studs ICC ESR-2174 (Available)
- 12) Plywood Panel to Steel Framing ICC ER-5380 (Available)
- 13) Florida Building Code Declaration #DCA06-DEC-282 (Available)

Please visit <http://www.ramset.com/approvals.asp> for copies of all reports.

Effective January 1, 2009, ITW Buildex has transitioned the selling of the GypFast product line to ITW Ramset. The fasteners continue to be manufactured by ITW Buildex; fastener head stamping and design remain the same. All approvals, listings and tests citing ITW Buildex should be considered valid for fasteners sold under the ITW Ramset name.

EXTERIOR SHEATHING TO STEEL



GF112

Ramset GypFast Fastener

VS



S-12

S-12 Self Drilling Screw

ASTM E-330 NEGATIVE WIND TEST

70.9 PSF	5/8 Dens-Glass Gold	63.5 PSF
69.0 PSF	5/8 Exterior Gypsum	—

Test in 18 Gauge Steel, 24" O.C., Vertical Orientation. **Failure mode of GypFast Fastener in All Cases was Pullover of The Gypsum Over the Fastener Head.** Results are Average Pounds Per Square Foot to System Failure.

PULLOUT TEST

285	20 Gauge Steel	194
393	18 Gauge Steel	317
574	16 Gauge Steel	437
659	14 Gauge Steel	930
923	12 Gauge Steel	911

Results Are In Ultimate, Average Pounds

CORROSION DATA ASTM B117 SALT SPRAY

1560 hours (10% Red Rust)	Driven	
3240 Hours (10% Red Rust)	UnDriven	24 Hours (5% Red Rust)

GypFast Fastener has Climacoat Long Life Polymer Coating; S-12 Screw has .0002" Electro Zinc and Clear Chromate.

GYPFAST®



EXTERIOR SHEATHING TO STEEL

GYPFAST[®]

PERFORMANCE SUBMITTAL

GypFast fasteners for the attachment of gypsum sheathing to light gage steel framing

ALLOWABLE NEGATIVE LOADS USING RAMSET GYPFAST FASTENERS

SHEATHING TYPE	MINIMUM STEEL STUD GAGE	MAXIMUM STEEL STUD SPACING (IN)	FASTENER SPACING (IN)	ALLOWABLE NEGATIVE LOAD (PSF)
1/2" GP DensGlass Gold Exterior Sheathing	20g to 12g	24	8	6
		16	8	8
5/8" GP DensGlass Gold Fireguard Type X Sheathing	20g to 12g	24	8	24
		16	8	32
1/2" USG Sheetrock Brand Sheathing	20g to 12g	24	8	12
		16	8	16
5/8" USG Sheetrock Brand Fire Code Type X Sheathing	20g to 12g	24	8	18
		16	8	24
1/2" USG Fiberock Brand Aquatough	20g to 12g	24	8	30
		16	8	40
5/8" USG Securock Glass-Mat Sheathing	18g	16	8	35
5/8" CertainTeed GlasRoc Sheathing Type X	18g	24	8	20
5/8" CertainTeed GlasRoc Sheathing Type X	16g	24	8	18
National Gypsum e2XP Extended Exposure Sheathing	18G	16	8	39

1. Tested in accordance with ASTM E330 & ICC-ES AC259
2. Values shown reflect a 3:1 safety factor
3. The fasteners must be driven to a depth at which the shank pierces the steel, such that the tip protrudes from the base metal a minimum of 1/2-inch
4. Tabulated values do not allow any overdriving of fasteners into sheathing



Georgia-Pacific Gypsum, LLC

133 Peachtree Street, NE
8th Floor
Atlanta, Georgia 30303

April 27, 2010

Mr. Jason Roxburgh
Drywall Marketing Manager
ITW Ramset
700 High Grove Blvd
Glendale Heights, IL 60139

Subject: **ITW Ramset GYPFAST Fastening System testing with
Georgia-Pacific Gypsum DensGlass® Exterior Sheathing**

Dear Mr. Roxburgh,

Georgia-Pacific Gypsum has reviewed ITW Ramset Corp PEI test report 2009-1297 and ICC-ES Evaluation report ESR-2174. The values submitted indicate that the GF112 GYPFAST Fastener System tested with 5/8" **DensGlass®** Exterior Sheathing provides structural support that meets and/or exceeds the tested values for the gypsum sheathing products found in ESR-2174.

GYPFAST fastener system must be installed in accordance with manufacturer's recommendations, ICC-ES Evaluation Service Report ESR-2174 and ICC-ES Acceptance Criteria AS259. Georgia-Pacific Gypsum, LLC does not warrant application and performance of fastening systems. Application and performance is the sole responsibility of ITW RAMSET.

Sincerely,



Daniel W. Kernan
DensGlass® Product Manager

GYPFAST[®]



Technical Innovation Center

Brian G. Randall
Business & Technical Development Manager
5901 Carnegie Blvd.
Charlotte, NC 28209
704-551-5819
BrianR@NationalGypsum.com

February 8, 2010

Mr. Jason Roxburgh
Drywall Marketing Manager
ITW Ramset
700 High Grove Blvd.
Glendale Heights, IL 60139

Subject: ITW Ramset GypFast Fastening System testing with
National Gypsum **eXP**[®] *Extended Exposure Sheathing*

Dear Mr. Roxburgh,

NGC has reviewed ITW RAMSET Corp PEI test report 2009-1297 and ICC-ES Evaluation report ESR-2174. We recognize that those reports indicate that the GF112 GYPFAST Fastener System tested with 5/8" **eXP**[®] Extended Exposure Sheathing provides structural support that meets or exceeds the tested values for the gypsum sheathing products found in ESR-2174.

Application of the GYPFAST fasteners must comply with the instructions and recommendations found in the manufacturers' literature, ICC-ES Evaluation Service Report ESR-2174 and ICC-ES Acceptance Criteria AC259. Application and performance of the GYPFAST Fastener System is the sole responsibility of ITW RAMSET.

Yours truly,



Brian G. Randall
Business & Technical Development Manager

CertainTeed Gypsum
4300 West Cypress St., Ste. 500
Tampa, FL 33607
Tel: (813) 286-3900 • Fax: (813) 286-3991
www.certainteed.com

CertainTeed 

February 13, 2009

Mr. Jason Roxburgh
Drywall Marketing Manager
ITW Ramset
700 High Grove Blvd.
Glendale Heights, IL 60139

Subject: **CertainTeed GlasRoc® Sheathing Type X with ITW Ramset GypFast Fastening System**

Dear Mr. Roxburgh:

CertainTeed Gypsum conducted negative wind load structural performance tests on our GlasRoc Sheathing Type X with the ITW Ramset GypFast Fastening System. Testing was conducted under our former corporate name of BPB America Inc. in accordance with the ASTM E 330 test method and a copy of the RADCO test report no. RAD-3788 dated November 15, 2005 is enclosed.

This test report may be used to verify the structural performance of the ITW Ramset GypFast Fastening System with GlasRoc Sheathing Type X.

We request that ITW Ramset consider including GlasRoc Sheathing Type X as a product reference within ITW Ramset literature where applicable. The test report will also be available from CertainTeed Gypsum Marketing Technical Services for construction project review and approval purposes.

If you require additional information, please contact the Marketing Technical Services Department at 1-800-233-8990.

Sincerely,



Douglas C. Gehring, P.E., CSI
Director, Marketing Technical Services

CertainTeed Gypsum, Inc.

Temple-Inland

10/14/10

Jason Roxburgh
Drywall Marketing Manager
ITW Ramset
700 High Grove Blvd
Glendale Hts, IL 60139

Dear Mr. Roxburgh,

Temple-Inland has reviewed the ITW Ramset Evaluation Report ESR-2174 and see that the Gyp-Fast fastening system has been approved for use in attaching gypsum sheathing to metal studs by the ICC. We have additionally reviewed the PEI ASTM E330 negative pressure test report #2009-1297 dated 11/17/2010, which tested 5/8" GreenGlass. From the test data, we see that 5/8" GreenGlass sheathing, when installed correctly using the, GYPFAST Fastener system GF112, met or exceeded the test values for gypsum sheathing approved in ESR-2174. We approve it's use with our GreenGlass sheathing, when installed correctly.

Temple-Inland is not a producer of fasteners, and the application and performance of the GYPFAST fastener would be the sole responsibility of ITW Ramset. When used with Temple-Inland products, the GYPFAST fastener should be installed to conform with the ITW installation instructions, the evaluation report ESR-2174, ICC Acceptance Criteria AC 269, and with all applicable code requirements.

Richard Kenley
Marketing Manager NPD
Temple-Inland
303 South Temple
Diboll, TX 75941

PERIMETER TRACK TO CONCRETE

Drive Pins — Designed for use in concrete and structural steel applications.

1510: 1-1/4", Head Diameter - .300

1512: 1-1/2", Head Diameter - .300



FASTENERS IN NORMAL WEIGHT CONCRETE

PART NUMBER SERIES	SHANK DIAMETER (INCH)	MINIMUM PENETRATION (INCH)	INSTALLED IN STONE AGGREGATE CONCRETE CONCRETE COMPRESSIVE STRENGTH ALLOWABLE LOAD – <i>Ultimate Load</i>					
			2000 PSI			4000 PSI		
			TENSION (LBS)		SHEAR (LBS)	TENSION (LBS)		SHEAR (LBS)
1500 Series	0.145	1-1/4	159 <i>1078</i>	265 <i>1665</i>	179 <i>1043</i>	267 <i>1538</i>		
		1-1/2	154 <i>1450</i>	340 <i>2027</i>	209 <i>1357</i>	342 <i>1712</i>		

Note 1: ALLOWABLE loads are shown in the **LARGE BOLD** font, *Ultimate* loads are shown in *smaller italic* font. **Note 2:** Testing conducted in accordance with ICC AC70 & ASTM E1190. **Note 3:** Safety factors are based on coefficient of variation. In accordance with ICC AC70, the safety factor will be no less than 5. **Note 4:** Values shown in concrete are for the fastener only. Connected members must be investigated separately. **Note 5:** Cyclic, fatigue, shock loads, and other design criteria may require a different safety factor. **Note 6:** Job site testing may be required to determine actual job site values. **Note 7:** Minimum edge distance is 3 inches unless otherwise approved. **Note 8:** For SI: 1 lbf = 4.448 N, 1 inch = 25.4 mm, 1 ksi = 6.89MPa

Tables converted to metric are available on our website.

Power Point Pins — Designed for fastening into harder concrete and for increased values.

SP114: 1-1/4", Head Diameter - .300

SP112: 1-1/2", Head Diameter - .300



FASTENERS IN NORMAL WEIGHT CONCRETE

PART NUMBER SERIES	SHANK DIAMETER (INCH)	MINIMUM PENETRATION (INCH)	INSTALLED IN STONE AGGREGATE CONCRETE CONCRETE COMPRESSIVE STRENGTH ALLOWABLE LOAD – <i>Ultimate Load</i>					
			2000 PSI		4000 PSI		6000 PSI	
			TENSION (LBS)		SHEAR (LBS)	TENSION (LBS)		SHEAR (LBS)
SP SERIES	.150/.180	1	154 <i>1043</i>	200 <i>1173</i>	243 <i>1307</i>	175 <i>1037</i>	189 <i>1125</i>	210 <i>1177</i>
		1-1/4	207 <i>1553</i>	230 <i>1636</i>	298 <i>1749</i>	218 <i>1471</i>	213 <i>1568</i>	305 <i>1780</i>
		1-1/2	-----	-----	384 <i>2126</i>	391 <i>1957</i>	239 <i>1886</i>	594 <i>2968</i>

Note 1: ALLOWABLE loads are shown in the **LARGE BOLD** font, *Ultimate* loads are shown in *smaller italic* font. **Note 2:** Testing conducted in accordance with ICC AC70 & ASTM E1190. **Note 3:** Safety factors are based on coefficient of variation. In accordance with ICC AC70, the safety factor will be no less than 5. **Note 4:** Values shown in concrete are for the fastener only. Connected members must be investigated separately. **Note 5:** Cyclic, fatigue, shock loads, and other design criteria may require a different safety factor. **Note 6:** Job site testing may be required to determine actual job site values. **Note 7:** Minimum edge distance is 3 inches unless otherwise approved. **Note 8:** For SI: 1 lbf = 4.448 N, 1 inch = 25.4 mm, 1 ksi = 6.89MPa

Tables converted to metric are available on our website.

TRACK OR CLIPS TO STEEL

Drive Pins — Designed for use in concrete and structural steel applications.

1503K: 1/2" Knurled, Head Diameter = .300

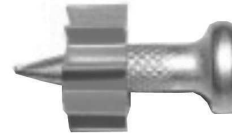

PART NUMBER SERIES	SHANK DIA. (INCH)	TYPE OF SHANK	INSTALLED IN A36 STRUCTURAL STEEL—STEEL THICKNESS (INCHES)							
			ALLOWABLE LOAD — <i>Ultimate Load</i>							
			3/16		1/4		3/8		1/2	
TENSION (LBS)	SHEAR (LBS)	TENSION (LBS)	SHEAR (LBS)	TENSION (LBS)	SHEAR (LBS)	TENSION (LBS)	SHEAR (LBS)			
1503K	0.145	KNURLED	296 <i>1633</i>	636 <i>3516</i>	584 <i>3384</i>	659 <i>3822</i>	680 <i>3755</i>	730 <i>4030</i>	253 <i>1459</i> ⁸	293 <i>1632</i> ⁸

PART NUMBER SERIES	SHANK DIA. (INCH)	TYPE OF SHANK	INSTALLED IN A572 GRADE 50 STRUCTURAL STEEL—STEEL THICKNESS (INCHES)							
			ALLOWABLE LOAD — <i>Ultimate Load</i>							
			3/16		1/4		3/8		1/2	
TENSION (LBS)	SHEAR (LBS)	TENSION (LBS)	SHEAR (LBS)	TENSION (LBS)	SHEAR (LBS)	TENSION (LBS)	SHEAR (LBS)			
1503K	0.145	KNURLED	260 <i>1609</i>	499 <i>3182</i>	579 <i>3411</i>	725 <i>4272</i>	383 <i>2216</i> ⁷	595 <i>3431</i> ⁷	----	----

Note 1: ALLOWABLE loads are shown in the **LARGE BOLD** font, *Ultimate* loads are shown in *smaller italic* font. **Note 2:** Testing conducted in accordance with ICC AC70 & ASTM E1190. **Note 3:** Safety factors are based on coefficient of variation. In accordance with ICC AC70, the safety factor will be no less than 5. **Note 4:** Cyclic, fatigue, shock loads, and other design criteria may require a different safety factor. **Note 5:** Job site testing may be required to determine actual job site values. **Note 6:** Values shown are for fastenings that have the entire pointed end of the fastener driven through the steel plate; except as noted below. **Note 7:** Fastener penetration is 3/8" minimum. **Note 8:** Fastener penetration is 7/16" minimum. **Note 9:** Fastener penetration is 1/2" minimum. **Note 10:** For SI: 1 lbf = 4.448 N, 1 inch = 25.4 mm, 1 ksi = 6.89MPa. Tables converted to metric are available on our website.

Power Point Pins — Designed for harder steel and for increased values. Head Diameter = .300

SP12: 1/2" Pin

SP58: 5/8" Pin

SP58TH: 5/8 Top Hat Pin

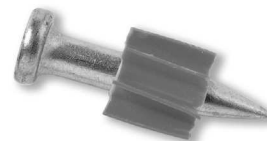

SP Series

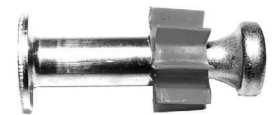

SP58TH

PART NUMBER SERIES	SHANK DIA. (INCH)	TYPE OF SHANK	INSTALLED IN A36 STRUCTURAL STEEL—STEEL THICKNESS (INCHES)									
			ALLOWABLE LOAD — <i>Ultimate Load</i>									
			3/16		1/4		3/8		1/2		3/4	
TENSION (LBS)	SHEAR (LBS)	TENSION (LBS)	SHEAR (LBS)	TENSION (LBS)	SHEAR (LBS)	TENSION (LBS)	SHEAR (LBS)	TENSION (LBS)	SHEAR (LBS)			
SP	0.150	SMOOTH	385 <i>2107</i>	662 <i>3618</i>	445 <i>2549</i>	477 <i>2736</i>	393 <i>2145</i>	574 <i>3137</i>	948 <i>5180</i>	597 <i>3500</i>	234 <i>1244</i> ⁸	356 <i>1895</i> ⁸

PART NUMBER SERIES	SHANK DIA. (INCH)	TYPE OF SHANK	INSTALLED IN A572 GRADE 50 STRUCTURAL STEEL—STEEL THICKNESS (INCHES)									
			ALLOWABLE LOAD — <i>Ultimate Load</i>									
			3/16		1/4		3/8		1/2		3/4	
TENSION (LBS)	SHEAR (LBS)	TENSION (LBS)	SHEAR (LBS)	TENSION (LBS)	SHEAR (LBS)	TENSION (LBS)	SHEAR (LBS)	TENSION (LBS)	SHEAR (LBS)			
SP	0.150	SMOOTH	356 <i>2123</i>	569 <i>3394</i>	554 <i>3232</i>	637 <i>3710</i>	604 <i>3447</i>	602 <i>3437</i>	814 <i>4473</i> ⁹	820 <i>4503</i> ⁹	243 <i>1362</i> ⁸	381 <i>2141</i> ⁸

Note 1: ALLOWABLE loads are shown in the **LARGE BOLD** font, *Ultimate* loads are shown in *smaller italic* font. **Note 2:** Testing conducted in accordance with ICC AC70 & ASTM E1190. **Note 3:** Safety factors are based on coefficient of variation. In accordance with ICC AC70, the safety factor will be no less than 5. **Note 4:** Cyclic, fatigue, shock loads, and other design criteria may require a different safety factor. **Note 5:** Job site testing may be required to determine actual job site values. **Note 6:** Values shown are for fastenings that have the entire pointed end of the fastener driven through the steel plate; except as noted below. **Note 7:** Fastener penetration is 3/8" minimum. **Note 8:** Fastener penetration is 7/16" minimum. **Note 9:** Fastener penetration is 1/2" minimum. **Note 10:** For SI: 1 lbf = 4.448 N, 1 inch = 25.4 mm, 1 ksi = 6.89MPa. Tables converted to metric are available on our website.

TRACK TO CONCRETE AND STEEL



Designed for Harder Concrete and Steel and for Increased Values Track to Concrete —

T3034B: 3/4" Concrete Pin with T3 Fuel Cell

T3034S: 3/4" Step Shank Pin with T3 Fuel Cell, Designed for Difficult Concrete

PART NUMBER SERIES	SHANK DIAMETER (INCH)	MINIMUM PENETRATION (INCH)	INSTALLED IN STONE AGGREGATE CONCRETE – CONCRETE COMPRESSIVE STRENGTH ALLOWABLE LOAD – <i>Ultimate Load</i>							
			2000 PSI		4000 PSI		6000 PSI			
			TENSION (LBS)	SHEAR (LBS)	TENSION (LBS)	SHEAR (LBS)	TENSION (LBS)	SHEAR (LBS)	TENSION (LBS)	SHEAR (LBS)
T3 Straight Shank	0.125	5/8	83 <i>414</i>	109 <i>611</i>	78 <i>426</i>	80 <i>574</i>	-----	-----	-----	-----
		3/4	107 <i>541</i>	156 <i>855</i>	104 <i>593</i>	195 <i>977</i>	-----	-----	-----	-----
T3 Step Shank	0.104 / 0.125	5/8	-----	-----	60 <i>357</i>	117 <i>587</i>	107 <i>533</i>	191 <i>957</i>		

PART NUMBER SERIES	SHANK DIAMETER (INCH)	MINIMUM PENETRATION (INCH)	INSTALLED IN STONE AGGREGATE CONCRETE – CONCRETE COMPRESSIVE STRENGTH ALLOWABLE LOAD – <i>Ultimate Load</i>							
			3000 PSI LIGHT WEIGHT CONCRETE		3000 PSI LIGHT WEIGHT CONCRETE WITH METAL DECK		HOLLOW CONCRETE MASONRY UNITS (CMU) FACE SHELL			
			TENSION (LBS)	SHEAR (LBS)	TENSION (LBS)	SHEAR (LBS)	TENSION (LBS)	SHEAR (LBS)	TENSION (LBS)	SHEAR (LBS)
T3 Straight Shank	0.125	5/8	84 <i>418</i>	108 <i>540</i>	72 <i>361</i>	242 <i>1210</i>	151 <i>754</i>	-----	-----	-----
		3/4	108 <i>540</i>	173 <i>864</i>	93 <i>470</i>	288 <i>1442</i>	-----	-----	-----	-----
T3 Step Shank	0.104 / 0.125	5/8	-----	-----	54 <i>269</i>	230 <i>1150</i>	71 <i>357</i>	123 <i>613</i>		

Note 1: ALLOWABLE loads are shown in the **LARGE BOLD** font, *Ultimate* loads are shown in *smaller italic* font. **Note 2:** Testing conducted in accordance with ICC AC70 & ASTM E1190. **Note 3:** Safety factors are based on coefficient of variation. In accordance with ICC AC70, the safety factor will be no less than 5. **Note 4:** Values shown in concrete are for the fastener only. Connected members must be investigated separately. **Note 5:** Cyclic, fatigue, shock loads, and other design criteria may require a different safety factor. **Note 6:** Job site testing may be required to determine actual job site values. **Note 7:** Minimum edge distance in concrete is 3 inches unless otherwise approved. **Note 8:** For SI: 1 lbf = 4.448 N, 1 inch = 25.4 mm, 1 ksi = 6.89MPa. **Note 9:** Face Shell minimum 1-1/4" thick.

Track to Steel —

T3012: 1/2" Steel Pin with T3 Fuel Cell

PART NUMBER	SHANK DIA. (INCH)	TYPE OF SHANK	INSTALLED IN A36 STRUCTURAL STEEL – STEEL THICKNESS INCHES ALLOWABLE LOAD – <i>Ultimate Load</i>					
			3/16 (.1875)		1/4 (.250)		3/8 (.375)	
			TENSION (LBS)	SHEAR (LBS)	TENSION (LBS)	SHEAR (LBS)	TENSION (LBS)	SHEAR (LBS)
T3012	0.125	SMOOTH	63 <i>676</i>	162 <i>1356</i>	239 <i>1285</i>	211 <i>1417</i>	113 <i>914</i> ⁷	197 <i>1327</i> ⁷
T3012S	0.125	TAPER SMOOTH	-----	-----	237 <i>1184</i>	356 <i>1782</i>	189 <i>943</i> ⁹	392 <i>1960</i> ⁷
INSTALLED IN ASTM A 572 GRADE 50 STEEL – STEEL THICKNESS INCHES								
T3012	0.125	SMOOTH	103 <i>733</i>	222 <i>1682</i>	147 <i>950</i>	119 <i>973</i>	147 <i>856</i> ⁸	112 <i>1014</i> ⁸

Note 1: ALLOWABLE loads are shown in the **LARGE BOLD** font, *Ultimate* loads are shown in *smaller italic* font. **Note 2:** Testing conducted in accordance with ICC AC70 & ASTM E1190. **Note 3:** Safety factors are based on coefficient of variation. In accordance with ICC AC70, the safety factor will be no less than 5. **Note 4:** Cyclic, fatigue, shock loads and other design criteria may require a different safety factor. **Note 5:** Job site testing may be required to determine actual job site values. **Note 6:** Values shown are for fastenings that have the entire pointed end of the fastener driven through the steel plate; except as noted below. **Note 7:** Fastener penetration is .29" minimum. **Note 8:** Fastener penetration is .27" minimum. **Note 9:** Fastener penetration is .25" minimum. **Note 10:** For SI: 1 lbf = 4.448 N, 1 inch = 25.4 mm, 1 ksi = 6.89MPa. Tables converted to metric are available on our website.

TRACK TO CONCRETE



Black Pin



Plated Step Shank Pin

Track to Concrete —

FPP034B: 3/4" Black Pin

FPP034S: 3/4" Plated Step Shank Pin

PART NUMBER SERIES	SHANK DIAMETER (INCH)	MINIMUM PENETRATION (INCH)	INSTALLED IN STONE AGGREGATE CONCRETE – CONCRETE COMPRESSIVE STRENGTH					
			ALLOWABLE LOAD – <i>Ultimate Load</i>					
			2000 PSI		3000 PSI		4000 PSI	
		TENSION (LBS)	SHEAR (LBS)	TENSION (LBS)	SHEAR (LBS)	TENSION (LBS)	SHEAR (LBS)	
FPP - Straight Shank	0.109	5/8	60 <i>434</i>	55 <i>546</i>	55 <i>453</i>	75 <i>615</i>	55 <i>472</i>	95 <i>685</i>
		3/4	60 <i>595</i>	80 <i>650</i>	55 <i>583</i>	95 <i>699</i>	55 <i>571</i>	115 <i>749</i>
FPP - Step Shank	0.104/0.118	3/4	-----	-----	-----	-----	51 <i>256</i>	83 <i>418</i>

PART NUMBER SERIES	SHANK DIAMETER (INCH)	MINIMUM PENETRATION (INCH)	INSTALLED IN STONE AGGREGATE CONCRETE – CONCRETE COMPRESSIVE STRENGTH					
			ALLOWABLE LOAD – <i>Ultimate Load</i>					
			3000 PSI LIGHT WEIGHT CONCRETE		3000 PSI LIGHT WEIGHT CONCRETE WITH METAL DECK		HOLLOW CONCRETE MASONRY UNITS (CMU) ANY LOCATION	
		TENSION (LBS)	SHEAR (LBS)	TENSION (LBS)	SHEAR (LBS)	TENSION (LBS)	SHEAR (LBS)	
FPP - Straight Shank	0.109	5/8	35 <i>234</i>	55 <i>403</i>	30 <i>239</i>	205 <i>1025</i>	35 <i>347</i>	50 <i>435</i>
		3/4	80 <i>630</i>	100 <i>756</i>	40 <i>330</i>	235 <i>1248</i>	-----	-----
FPP - Step Shank	0.104/0.118	3/4	-----	-----	-----	-----	36 <i>184</i>	34 <i>264</i>

Note 1: ALLOWABLE loads are shown in the **LARGE BOLD** font, *Ultimate* loads are shown in *smaller italic* font. **Note 2:** Testing conducted in accordance with ICC AC70 & ASTM E1190. **Note 3:** Safety factors are based on coefficient of variation. In accordance with ICC AC70, the safety factor will be no less than 5. **Note 4:** Values shown in concrete are for the fastener only. Connected members must be investigated separately. **Note 5:** Cyclic, fatigue, shock loads, and other design criteria may require a different safety factor. **Note 6:** Job site testing may be required to determine actual job site values. **Note 7:** Minimum edge distance in concrete is 3 inches unless otherwise approved. **Note 8:** For Sl: 1 lbf = 4.448 N, 1 inch = 25.4 mm, 1 ksi = 6.89MPa. **Note 9:** T3 straight shank allowable tension value in face shell of hollow CMU is 133 lbs. Tables converted to metric are available on our website.

TRACK TO STEEL



Black Pin



Plated Step Shank Pin

Track to Steel —

FPP012: 1/2" Plated Steel Pin

FPP012S: 1/2" Plated Step Shank Pin, Designed for Harder Steel

PART NUMBER	SHANK DIA. (INCH)	TYPE OF SHANK	INSTALLED IN A36 STRUCTURAL STEEL – STEEL THICKNESS INCHES					
			ALLOWABLE LOAD – <i>Ultimate Load</i>					
			3/16 (.1875)		1/4 (.250)		3/8 (.375)	
			TENSION (LBS)	SHEAR (LBS)	TENSION (LBS)	SHEAR (LBS)	TENSION (LBS)	SHEAR (LBS)
FPP012	0.109	SMOOTH	195 <i>1047</i>	292 <i>1570</i>	223 <i>1220</i>	278 <i>1526</i>	181 <i>1048</i> ⁷	185 <i>1076</i> ⁷
FPP012S	0.104/.118	SMOOTH	-----	-----	148 <i>744</i>	157 <i>787</i>	166 <i>832</i> ⁷	157 <i>787</i> ⁷

Note 1: ALLOWABLE loads are shown in the **LARGE BOLD** font, *Ultimate* loads are shown in *smaller italic* font. **Note 2:** Testing conducted in accordance with ICC AC70 & ASTM E1190. **Note 3:** Safety factors are based on coefficient of variation. In accordance with ICC AC70, the safety factor will be no less than 5. **Note 4:** Cyclic, fatigue, shock loads and other design criteria may require a different safety factor. **Note 5:** Job site testing may be required to determine actual job site values. **Note 6:** Values shown are for fastenings that have the entire pointed end of the fastener driven through the steel plate; except as noted below. **Note 7:** Fastener penetration is .31" minimum. **Note 8:** For SI: 1 lbf = 4.448 N, 1 inch = 25.4 mm, 1 ksi = 6.89MPa
Tables converted to metric are available on our website.

SOUND CONTROL SEALANT



Part No. SC200

R25562	UNDERWRITERS LABORATORIES INC. ® CLASSIFIED ADHESIVE 309U Surface Burning Characteristics APPLIED TO INORGANIC REINFORCED CEMENT BOARD*	NO. 13
	FLAME SPREAD0 SMOKE DEVELOPED.....0	
*Tested as applied in one 2-inch wide strip 0.032 inch thick. (Coverage: 11 percent of the exposed test sample area)		

SPECIAL CHARACTERISTICS

- Will not stain
- Excellent Aging Characteristics
- Excellent Adhesion Properties
- Complies with **SCAQMD, Rule 1168**
- Meets requirement for **LEED EQ Credit 4.1: Low-Emitting Materials: Adhesive & Sealants**
- Meets ASTM E84, ASTM C919, ASTM E90
- Tested in accordance with ASTM C731, ASTM C732, ASTM D2202, ASTM D2203, ASTM D2377
- Sound Transmission Data per ASTM E-90
- Test Panel w/o Ramset Sound Control Sealant STC=24
- Test Panel w/ Ramset Sound Control Sealant STC=52
- Ultra low VOC content 24 g/L"
- Mildew Resistant
- No Oil Migration
- ½ Hour Tack Free Time
- Excellent Extrudability
- Paintable After Cure
- Low Slump

PHYSICAL PROPERTIES & TECHNICAL INFORMATION

BASE: Synthetic Latex

TYPE: Water Base

COLOR: Off White

WEIGHT/GALLON: 11.4 lbs

SOLIDS: 73%

COVERAGE: 38 linear ft. using 3/8" bead

OPEN TIME: Up to 30 min. at 75°F and 50% relative humidity (ASTM 2377).

SHELF LIFE: 12 months

ODOR: Mild

STORAGE TEMP: 55°F to 85°F

KEEP FROM FREEZING DURING STORAGE.

APPLICATION TEMP: 40°F to 100°F

SERVICE TEMP: -30°F to 150°F

FLASH POINT: No flash to boiling.

FREEZE-THAW STABILITY: 5 cycles

WATER RESISTANCE: Excellent

MILDEW RESISTANCE: Excellent

DRY TIME: 48-72 Hours at 75°F and 50% relative humidity

PACKAGING INFORMATION:

ITEM NO.
SC200

SIZE
28 oz tube

PACKED
12/Cartron

WEIGHT
34 lbs./Cartron

DESCRIPTION

Ramset Sound Control Sealant is a latex based sealant that is used to reduce sound transmission and increase acoustical performance in gypsum wallboard partition systems. The sealant adheres firmly to wood, metal, concrete and gypsum dry wall surfaces. It is not recommended for gaps larger than 3/8". Can be used in smoke rated partitions. Not for use in fire-rated assemblies.

DIRECTIONS

Surface Preparation: Surfaces to be sealed must be clean, dry and free of oil, grease and other foreign material.

APPLICATION: To seal perimeters of all sound-rated wall systems, apply a 3/8" continuous bead of Ramset Sound Control Sealant around floor and ceiling runners, either wood or metal. Then apply another 3/8" continuous bead around all openings formed for electrical outlets, lights, heating ducts, etc.



SC200S SMOKE & SOUND ACOUSTICAL SPRAY DATA SHEET

APPLICATIONS

SMOKE CONTROL: Where stopping the passage of smoke is necessary such as in smoke barrier walls.

NOISE CONTROL: Where reducing the transmission of sound through wall openings is necessary to help ensure occupant privacy and peaceful environment.

INFECTIOUS/DUST CONTROL: Where reducing the transmission of dust and other airborne particulates through wall openings is necessary.

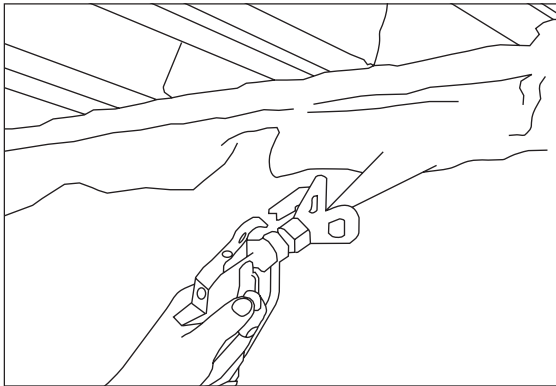

PRODUCT DESCRIPTION

SC200S Smoke & Sound Spray is a high quality acrylic latex spray designed for static or minimally dynamic linear joints or gaps in smoke rated barriers.

SC200S Smoke & Sound Spray is formulated to adhere to all common construction surfaces and may be applied using airless spray equipment or with a brush (for small applications and touch ups).

SC200S Smoke & Sound Spray dries to form a flexible shield against particulate air and smoke. Its premium latex binder system is totally resistant to water and will not re-emulsify after drying. SC200S Smoke & Sound Spray contains no inorganic fibers, asbestos, or solvents.

FEATURE	BENEFIT
• Economical	High performance without the high price!
• Water Resistant	Will not re-emulsify when dry.
• Water-Based	Easy installation, cleanup, and disposal.
• Safe	No solvents! No asbestos!
• Thixotropic	Offers high build application.
• Acoustically Tested	Reduces noise transmission.
• Low Abrasion	Longer pump life and less maintenance.
• Low VOCs	Safe, No solvents, Non-Halogenated

PERFORMANCE

When applied to a wet film thickness of 1/8" (3.2 mm) to 1/4" (6 mm) over appropriate backing materials, SC200S Smoke & Sound Spray provides an L Rating of Less Than 1 CFM/Lin Ft at ambient and elevated temperatures to minimize the transmission of particulate air and smoke.

LIMITATIONS: Use product as per manufacturer's instructions. Use only in applications per the manufacturer's published designs or specific recommendations. End user must ultimately determine the suitability of the product and/or design to his or her specific requirements and assumes responsibility for its use. **PRODUCT CONTAINS WATER AND IS CONDUCTIVE UNTIL DRY. DO NOT APPLY IN THE PRESENCE OF EXPOSED OR ENERGIZED ELECTRICAL CONDUCTORS.**

Properties	Smoke & Sound Spray
Color	White
Odor	Mild Latex
Specific Gravity	1.25
Solids Content	77%
Flame Spread (ASTM E84/UL723)	0
Smoke Developed (ASTM E84/UL723)	0
Movement/Elongation	±8%
Coverage	12.8 sq ft/gallon @1/8"
Viscosity	(0.31 m ² /L @ 3.2 mm) 150,000 – 200,000 cps
pH	7-8

Properties	Smoke & Sound Spray
Solvent Content	NA
In Service Temperature	≤120° F (49°C)
Storage Temperature	40-95° F (4-35°C)
Application Temperature	60-90° F (16-32°C)
Dry Time Tack Free Dry Through	*2 Hrs *24 to 48 Hrs
STC Rating (ASTM E90/ASTM C919)	61
VOC Content (EPA Method 24/ASTM D3960)	0.29 lb/gal. (34 g/L)
Shelf Life	12 Months

* Tack free and dry through time may be affected by weather conditions

SC200S SMOKE & SOUND ACOUSTICAL SPRAY DATA SHEET

SPECIFICATIONS

The SC200S smoke sealing spray shall be a water based, high quality latex coating and shall dry to a water resistant and flexible smoke barrier when dry. The coating shall be tested for smoke sealing, noise abatement (acoustical) properties and shall meet class A finish requirements when tested in accordance with ASTM E84 (UL723). The approved coating shall be SC200S Smoke & Sound Spray.

Specified Divisions

Division 7 – Section 07 90 00 – Joint Protection

Division 7 – Section 07 95 00 – Expansion Control

Division 9 – Section 09 20 00 – Plaster and Gypsum Board

Division 9 – Section 09 80 00 – Acoustic Treatment

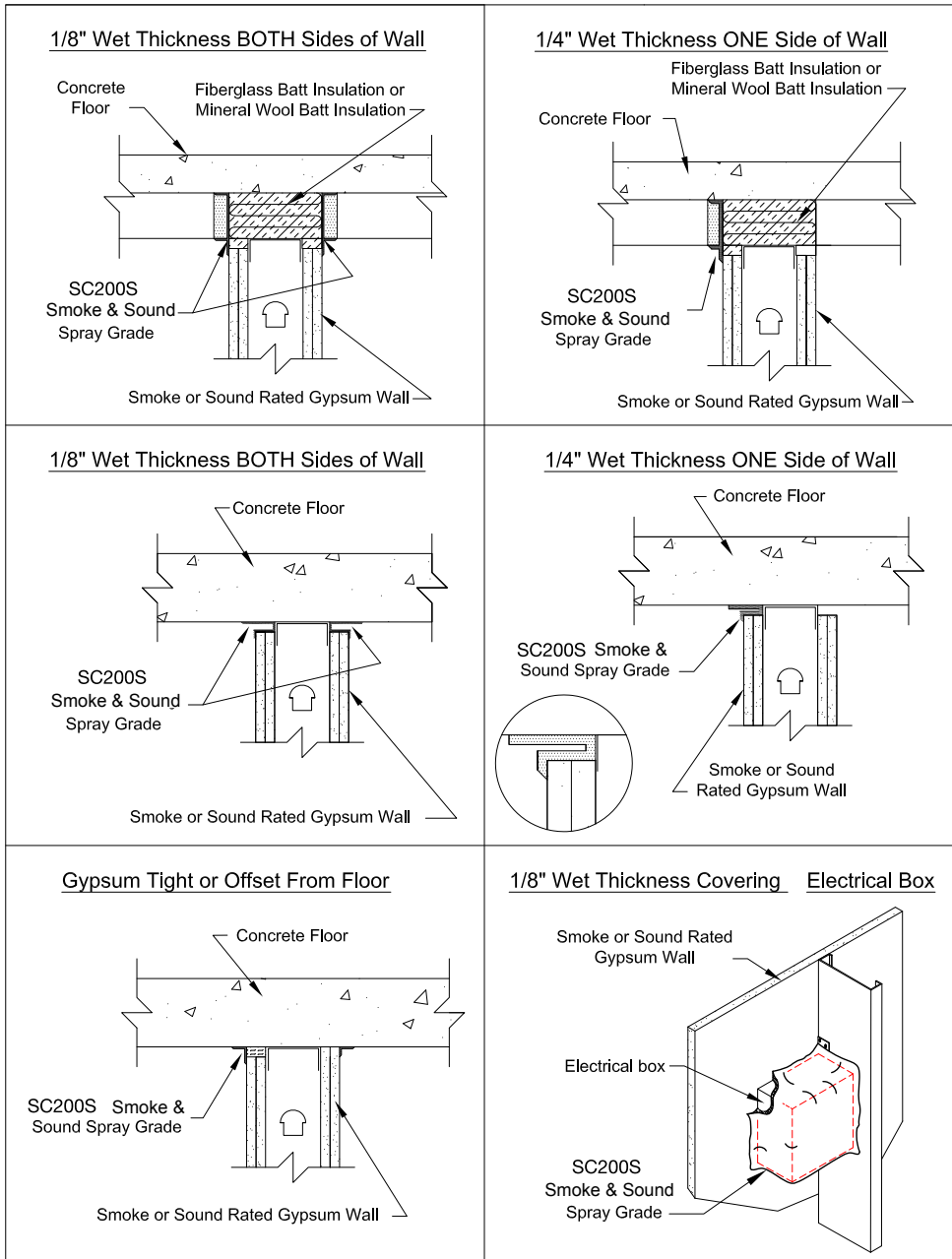

SC200S SMOKE & SOUND ACOUSTICAL SPRAY DATA SHEET

INSTALLATION INSTRUCTIONS

GENERAL: Areas to be sealed must be clean and free of frost, oil, loose dirt, rust or scale. Refer to Physical Properties for recommended storage and application temperatures. When applying coating at lower end of temperature range, warming the material to 70°F (21°C) will enhance drying characteristics. Drying time will vary according to prevailing temperature and humidity. Allow coating to thoroughly dry before exposure to moisture. Consult appropriate manufacturer's instructions. Forming or packing materials may be required as an integral part of various designs. Coating may be applied by airless sprayer up to 1/4" (6 mm) wet coating depth. If applying by brush or spraying on vertical surfaces where coating appears to be prone to slumping, multiple coats, or the application of a thin tack coat may be required. DO NOT ATTEMPT TO THIN PRODUCT BY ADDING WATER.

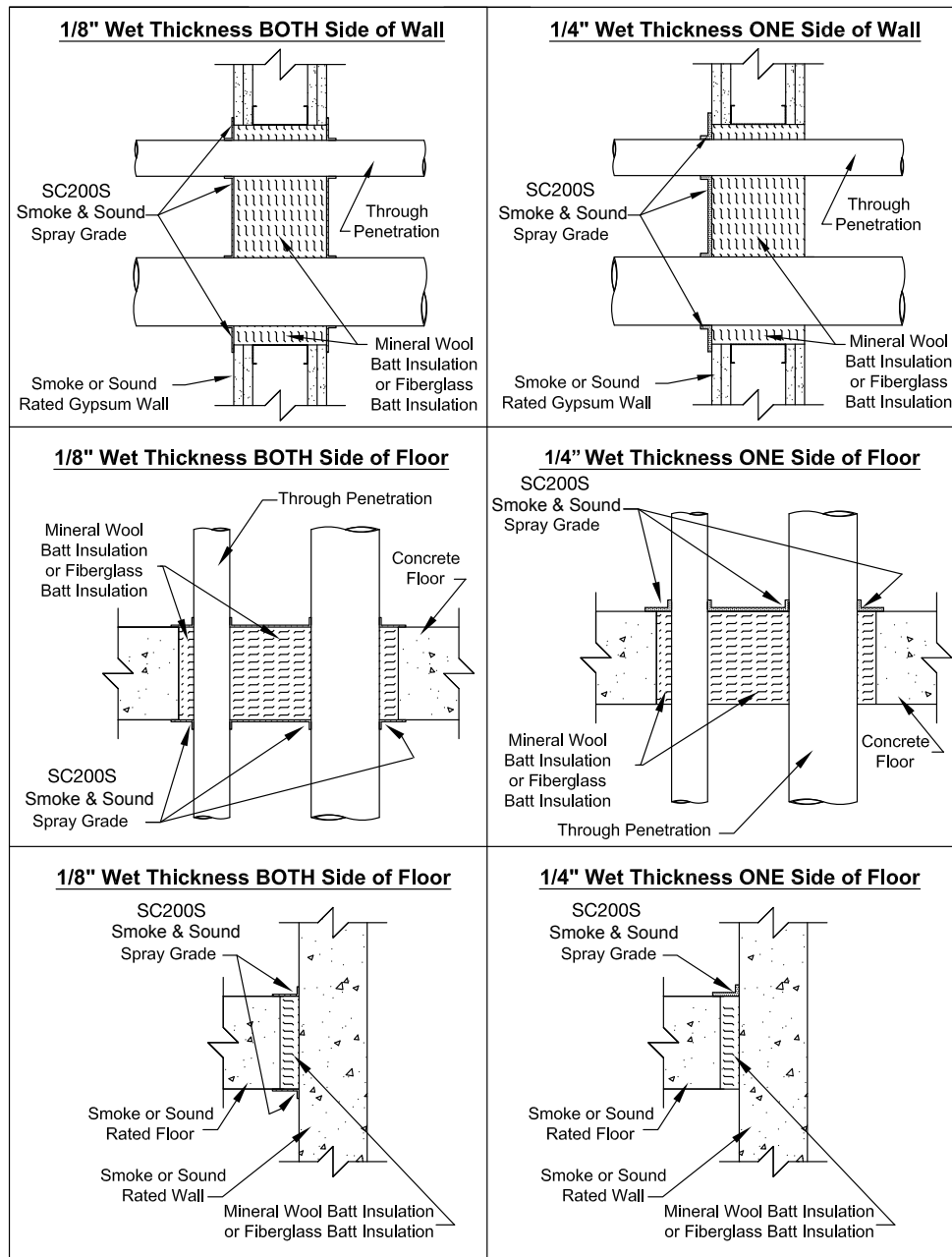

SC200S SMOKE & SOUND ACOUSTICAL SPRAY DATA SHEET

MAINTENANCE

Inspection: Installations should be inspected periodically for subsequent damage. Following safety precautions listed below and pertinent installation guidelines, remove coating in damaged areas down to undamaged material. Reapply fresh coating material to original coating thickness.

TECHNICAL SERVICE

Ramset provides toll free technical support at 800-816-6645.
Material Safety Data Sheets and other technical information are available upon request.

PRECAUTIONARY INFORMATION

Consult Material Safety Data Sheet for additional information on the safe handling and disposal of this material. Wash areas of skin contact with soap and water. Avoid contact with eyes. The use of an OSHA or NIOSH approved mask for dust and mist environment is recommended. Apply in areas with adequate ventilation.

CAUTION: COATING IS CONDUCTIVE UNTIL DRY. DO NOT APPLY TO OR IN THE PRESENCE OF ENERGIZED ELECTRICAL CONDUCTORS.

AVAILABILITY

SC200S Smoke & Sound Spray is available from authorized distributors worldwide. Consult factory for names and locations of the nearest sales representatives or distributors.

Part #	Description	Packaging	Size
SC200S	Smoke & Sound Acoustical Spray	Pail	5 Gallon (19.0 L)

NOTICE TO PURCHASER:

No warranties, express or implied, are made including merchantability and/or fitness for a particular purpose. Except for personal injury resulting from use of the product as directed, ITW Ramset shall not be liable in tort or contract for any loss or damage. Under no circumstances shall ITW Ramset, a division of Illinois Tool Works Inc., or its affiliates ("ITW Ramset") be liable for any loss or damage arising from the purchase, use, or inability to use this product, or for any special, indirect, incidental, or consequential damages. The user may send a sample of product to ITW Ramset for testing. If such testing proves a product defective, the user's sole and exclusive remedy is either reimbursement of the purchase price of the product or replacement of the container of product. No fabricator, installer, dealer, agent or employee of ITW Ramset has the authority to modify the obligations or limitations of this warranty. This warranty gives you specific legal rights, and you may also have other rights, which vary from state to state; therefore, some of the limitations stated above may not apply to you. It is to your benefit to save your documentation upon purchase of a product. The information and suggestions for use contained herein are believed to be accurate, but are not to be construed as warranties. User shall determine the suitability of the product for his or her intended use and shall assume all risk associated therewith.

MADE IN THE USA – COPYRIGHT © 2010 ITW RAMSET