

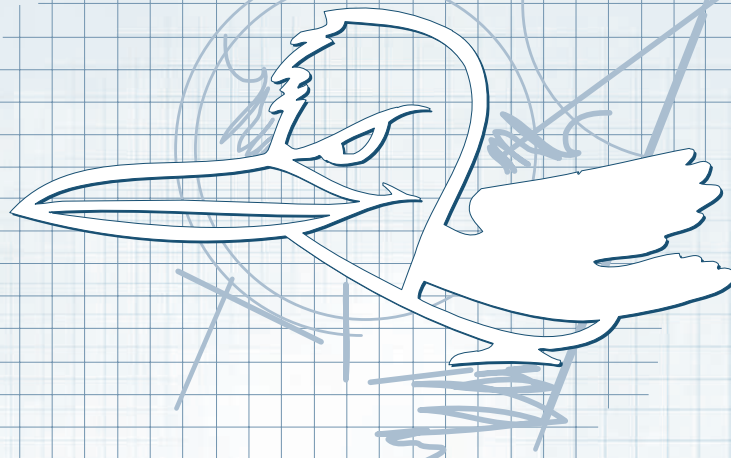

RED HEAD®

Fastening Applications Guide



This section highlights a variety of trade applications and provides information that will assist you in selecting the best fastening system for your application.

While these are not to be considered complete, they will give you an idea of how contractors use our products.

For example, on the Electrical Contractor page, you will find applications, such as junction box/panel boards and

suspended lighting. Next to the diagrams are the product name(s) and page number in this catalog where you will find complete information on these products needed for that particular application.

Curtain Wall Applications

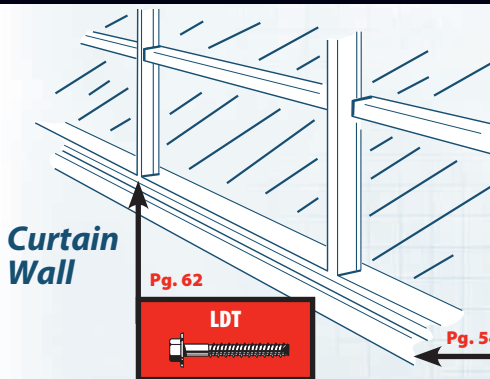

Curtain Wall

- 2006 IBC & 2009 IBC Compliant
- All seismic zone and cracked concrete approved
- Thru fixture fastening



Pg. 60



- Can be set thru fixture
- Available in stainless steel
- Can be set with torque wrench

- Design allows for expansion and contraction of the frame
- Finished head
- Works in multiple base materials

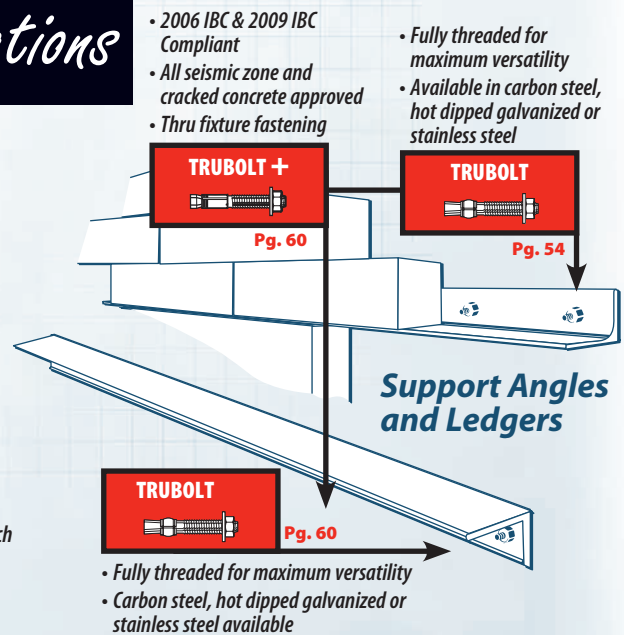

Support Angles and Ledgers

- 2006 IBC & 2009 IBC Compliant
- All seismic zone and cracked concrete approved
- Thru fixture fastening

- Fully threaded for maximum versatility
- Available in carbon steel, hot dipped galvanized or stainless steel



Pg. 60

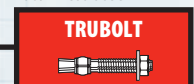

Pg. 54

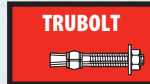

Pg. 60

- Fully threaded for maximum versatility
- Carbon steel, hot dipped galvanized or stainless steel available

For seismic recognition, see ICC-ES evaluation reports.

For installation guidelines for your application, please contact our Technical Services Department at 1-800-899-7890.

ITW Red Head®

Call our toll free number 800-899-7890 or visit our web site for the most current product and technical information at www.itwredhead.com



RED HEAD®

Electrical Contractor Applications



Pg. 76

- Simple to install
- Drill hole, hammer Redi-Drive into hole
- Available in several head styles and lengths

Junction Box/ Panel Boards

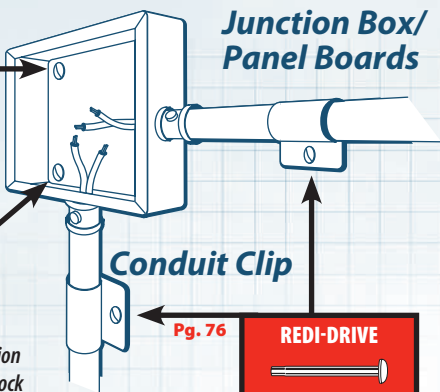

Pg. 80



- Counter sunk flathead style for flush installation
- Works in concrete or block
- Available in 3/16" and 1/4" diameters



- Simple to install
- Drill hole, hammer Redi-Drive into hole
- Available in several head styles and lengths

- Available in special 3/8" version for precast planks
- Available in sizes 1/4" thru 3/4" internal thread diameters



Pg. 67

Suspended Lighting

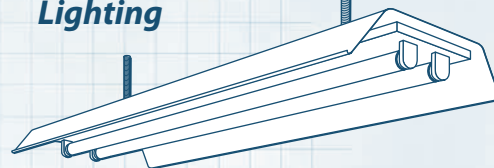

Transformers Switch Gear Electrical Enclosures

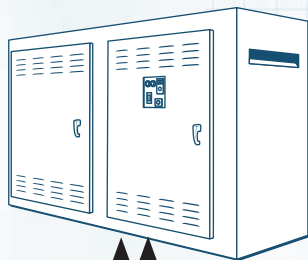

Pg. 54



- Available in carbon, hot dipped galvanized, 304 and 316 stainless steel

Pg. 60



- 2006 IBC & 2009 IBC Compliant
- All seismic zone and cracked concrete approved
- Thru fixture fastening

Unistrut-Cable Tray/Conduit

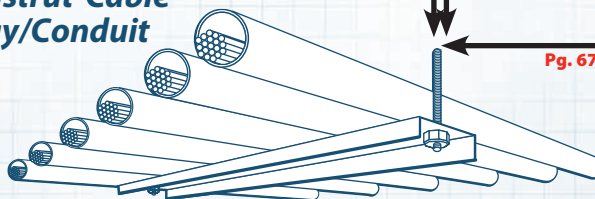

- Used with rod coupler
- 1/4" to 1" diameters

- 2006 IBC & 2009 IBC Compliant
- All seismic zone and cracked concrete approved
- Thru fixture fastening



Pg. 54



Pg. 60

Pg. 67



- Available in special 3/8" version for precast planks
- Available in sizes 1/4" thru 3/4" internal thread diameters

- Ideal for closely spaced groups of anchors



Pg. 20

Light Standards Poles

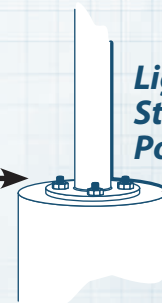

Pg. 31



- "Stress Free" anchor—can be used close to edges or in close spacing pattern



Pg. 97

- Removable
- Finished head
- Works in solid concrete, hollow block and brick

Wall Mounted Lighting



Pg. 71



- Counter sunk and threshold head styles also available
- Works in concrete, block and brick



- Works in solid concrete, hollow block and brick
- Cuts a thread into the mounted surface
- Finished head appearance

- Available in special 3/8" version for precast planks
- Available in sizes 1/4" thru 3/4" internal thread diameters



Pg. 67



Pg. 76

Suspended Pipe or Conduit

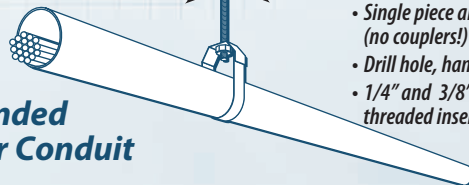

- Single piece anchors (no couplers!)
- Drill hole, hammer in
- 1/4" and 3/8" internally threaded inserts

For seismic recognition, see ICC-ES evaluation reports.

For installation guidelines for your application, please contact our Technical Services Department at 1-800-899-7890.

Mechanical Contractor Applications

Machinery and Equipment



- Vibration resistant
- Removable

Pg. 62



- High Load Capacity
- Suitable for use close to edge of slab
- Ideal for moderate to hot climates
- Can be used for oversized holes

Pg. 37

Pg. 31



- Vibration resistant
- Can be used in oversized and core drilled holes
- High load capacity

- Simple to install—drill hole and hammer in
- Fire resistant



Pg. 76

NOTE:
C6 and G5 both can be used for oversized holes when repairing pumps and machinery anchoring.

Pumps

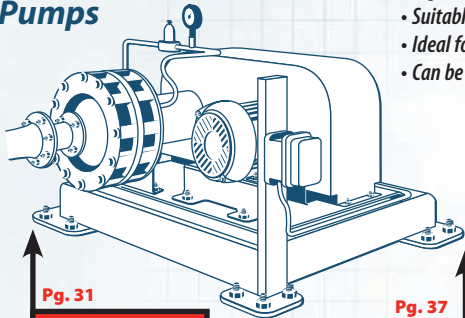

Pg. 31



- Corrosion resistant
- Vibration resistant
- NSF Approved

Pg. 37



- High Load Capacity
- Suitable for use close to edge of slab
- Ideal for moderate to hot climates
- Can be used for oversized holes

Ductwork/HVAC



Heavy-Duty Pipe Support

- 2006 IBC & 2009 IBC Compliant
- All seismic zone and cracked concrete approved
- Thru fixture fastening



Pg. 60

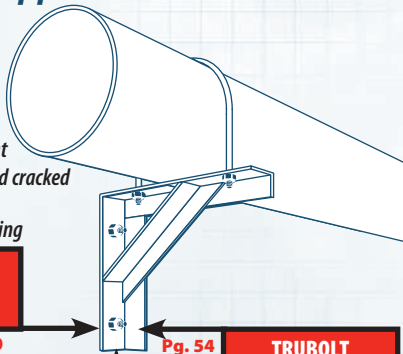

Pg. 54



- Carbon, hot dipped galvanized, 304 and 316 stainless steel
- 1/4" to 1" diameters

Pg. 31



- High load capacity
- Corrosion resistant
- NSF Approved

Pipe/Strut Attachment

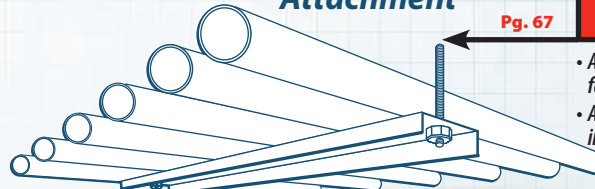

Pg. 67



- Available in special 3/8" version for prestressed concrete
- Available in 1/4" thru 3/4" internal thread diameters

Pg. 76



- 1-piece design (no couplers!)
- Drill hole, hammer in
- 1/4" and 3/8" internal threads

- Available in special 3/8" version for prestressed concrete
- Available in 1/4" thru 3/4" internal thread diameters



Pg. 67

Pipe Support, Fire Sprinkler



For seismic recognition, see ICC-ES evaluation reports.

For installation guidelines for your application, please contact our Technical Services Department at 1-800-899-7890.

ITW Red Head

Call our toll free number 800-899-7890 or visit our web site for the most current product and technical information at www.itwredhead.com

RED HEAD

Drywall Contractor & Carpenter Applications

Window and Door Frames

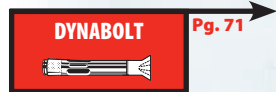

- Counter sunk and threshold head styles
- Works in concrete, block and brick



- Works in solid and hollow base material
- Removable
- Can be set flush with Phillips head if counter sunk

Drywall Track

Ceiling Track



- Simple to use—drill hole and hammer in
- Setting tool (RDST) available for tight spaces

Floor Track



- Simple to use—drill hole and hammer in
- Setting tool (RDST) available for tight spaces



- Counter sunk flathead style for flush installation
- Works in concrete or block
- Available in 3/16" and 1/4" diameters

Furring Strips

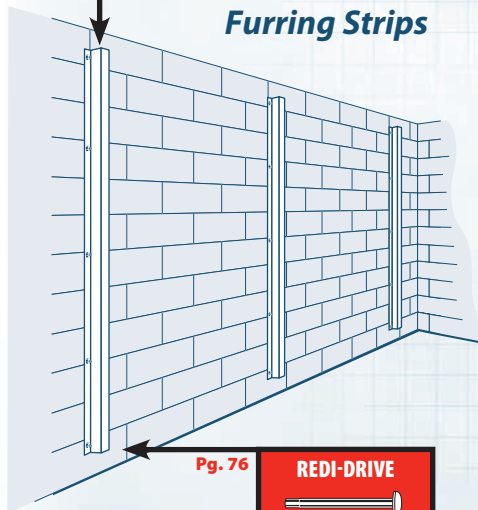

Framing/Sill Plating

- Drill hole, drive in by hand or impact wrench

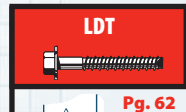

- Full threaded for maximum versatility
- Metro-Dade Approved
- Other approvals on page 55

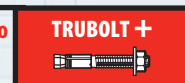
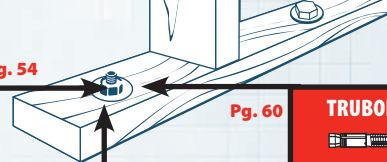

- 2006 IBC & 2009 IBC Compliant
- All seismic zone and cracked concrete approved
- Thru fixture fastening



- Fast cure
- Works in damp wet conditions
- Use A7 with threaded rod for this application

For seismic recognition, see ICC-ES evaluation reports.

For installation guidelines for your application, please contact our Technical Services Department at 1-800-899-7890.

Acoustical Ceiling Installer Applications

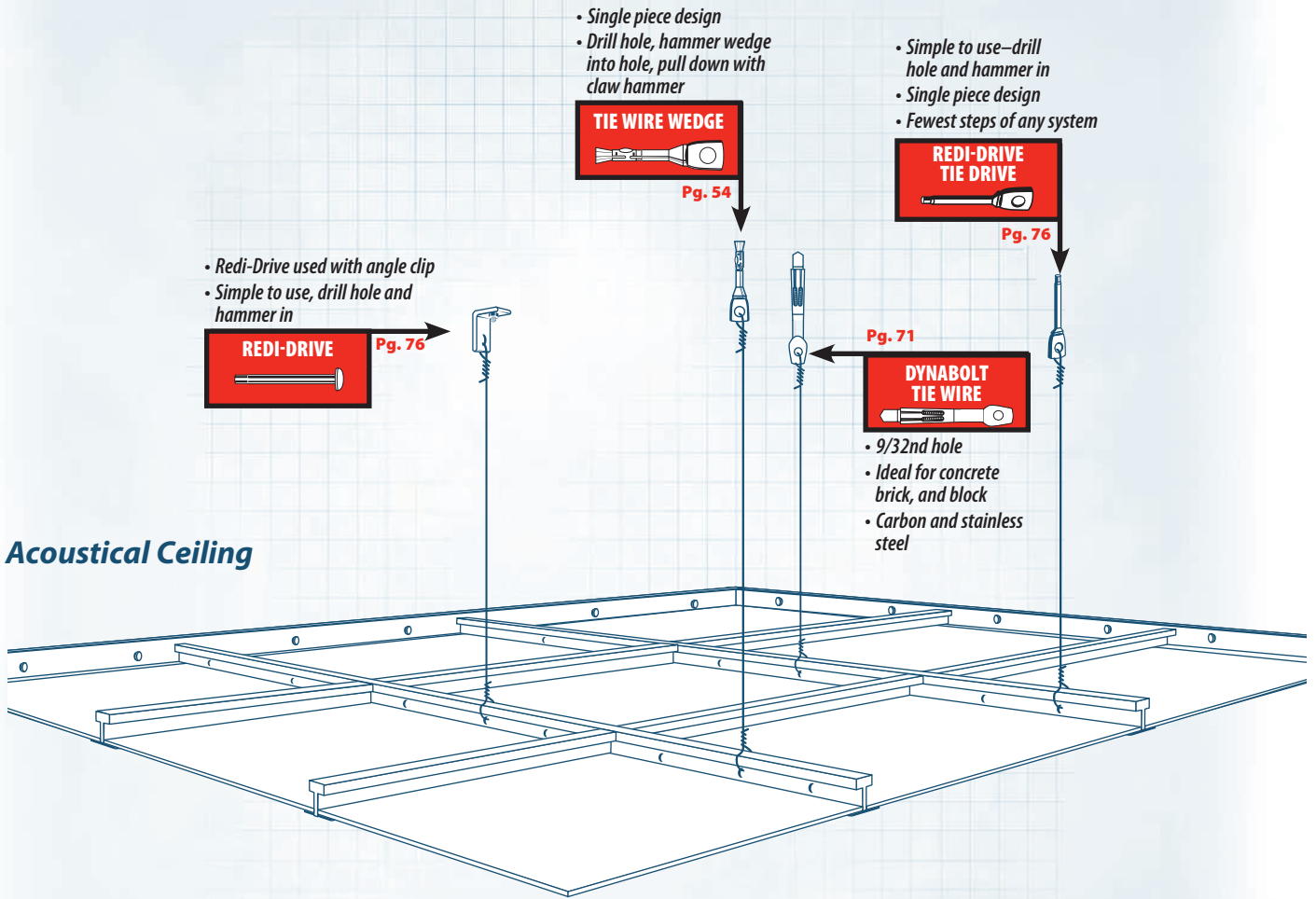

For seismic recognition, see ICC-ES evaluation reports.

For installation guidelines for your application, please contact our Technical Services Department at 1-800-899-7890.

ITW Red Head

Call our toll free number 800-899-7890 or visit our web site for the most current product and technical information at www.itwredhead.com

RED HEAD

Steel Erector Applications

Steel Beams/Columns

Pg. 37

G5 ADHESIVE

- Longer working time for positioning of steel
- Can be used in oversized holes
- Works in wet/damp conditions

Pg. 20

A7 ADHESIVE

- Ideal for closely spaced groups of anchors

Pg. 96

BOA COIL

- High shear strength
- Removable
- Reusable

Stairs and Ladders

- 2006 IBC & 2009 IBC Compliant
- All seismic zone and cracked concrete approved
- Thru fixture fastening

TRUBOLT +

Pg. 60

TRUBOLT

Pg. 54

- Can be set thru fixture
- Fast and immediate loading

Pg. 97

PRIMA

- Removable
- Finished head
- Works in solid concrete, hollow block and brick

Pg. 62

LDT

- Finished head
- Removable
- For use in concrete

Ornamental Iron

DYNABOLT

Pg. 71

- Multiple head styles
- Ideal for concrete, brick and block
- Carbon and stainless steel

Hand Railings

PRIMA

Pg. 97

- Removable
- Finished head
- Works in solid concrete, hollow block and brick

DYNABOLT

Pg. 71

- Multiple head styles
- Ideal for concrete, brick and block
- Carbon and stainless steel

Protective Railings and Fencing

- 2006 IBC & 2009 IBC Compliant
- All seismic zone and cracked concrete approved
- Thru fixture fastening

TRUBOLT +

Pg. 60

Pg. 97

PRIMA

- Removable
- Finished head
- Works in solid concrete, hollow block and brick

For seismic recognition, see ICC-ES evaluation reports.

For installation guidelines for your application, please contact our Technical Services Department at 1-800-899-7890.

Concrete & Masonry Contractor Applications

Concrete Block Reinforcement

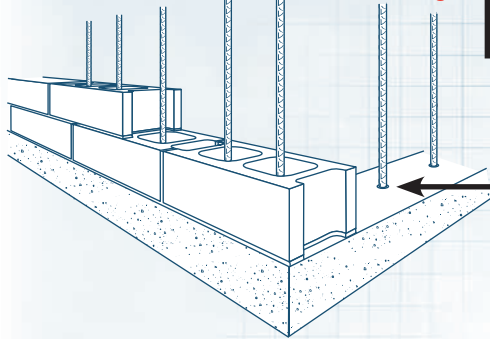

Pg. 31

- NSF Approved
- Vibration resistant
- Corrosion resistant



- Fast curing adhesive—ideal for moderate to hot climates

Rebar Doweling

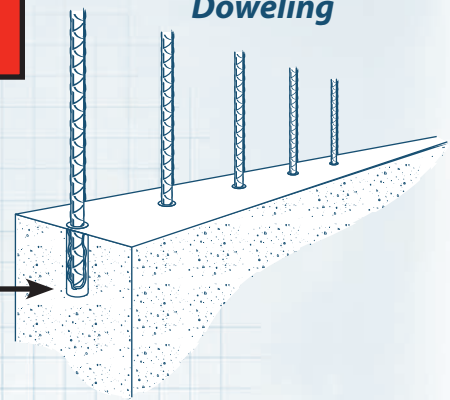

Pg. 20



- Fast curing adhesive—ideal for moderate to cold climates

Stone Attachment

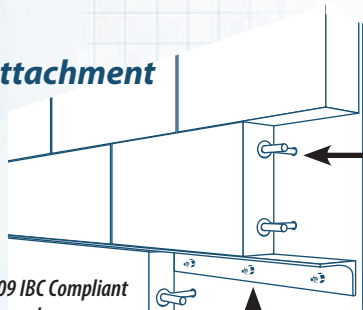

- 2006 IBC & 2009 IBC Compliant
- All seismic zone and cracked concrete approved
- Thru fixture fastening

Pg. 54



Pg. 60

- Fully threaded for maximum versatility
- Available in carbon, hot dipped galvanized and stainless steel

Ledger Angle Attachment

Brick Pinning

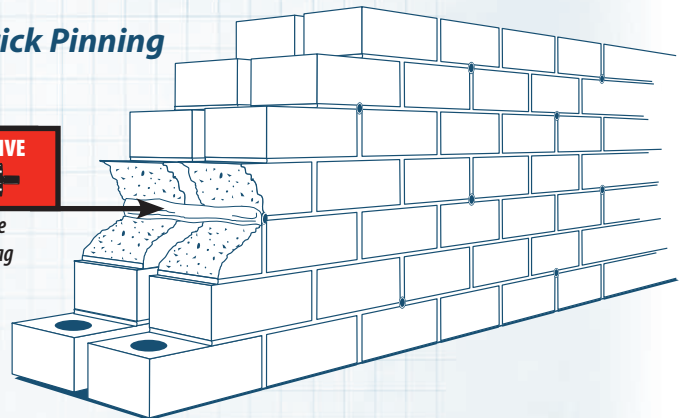

Pg. 20



- Compact space
- No-drip—no sag formula
- Easy clean up

Stone Attachment

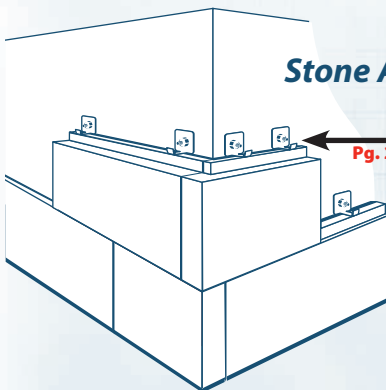

Pg. 20



- High load capacity in concrete block
- No drip—no sag formula
- Easy clean up

Concrete Formwork

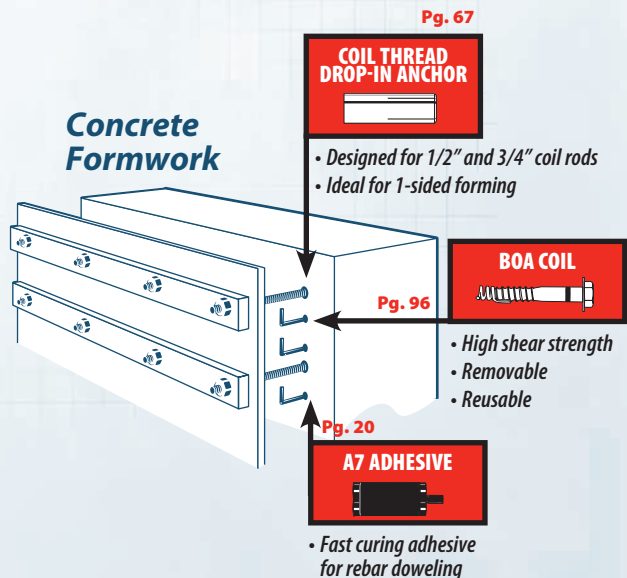

Pg. 67



- Designed for 1/2" and 3/4" coil rods
- Ideal for 1-sided forming

Pg. 96



- High shear strength
- Removable
- Reusable

Pg. 20



- Fast curing adhesive for rebar doweling

For seismic recognition, see ICC-ES evaluation reports.

For installation guidelines for your application, please contact our Technical Services Department at 1-800-899-7890.

ITW Red Head

Call our toll free number 800-899-7890 or visit our web site for the most current product and technical information at www.itwredhead.com

RED HEAD

Water & Waste Water Treatment Applications

Weirs and Gates

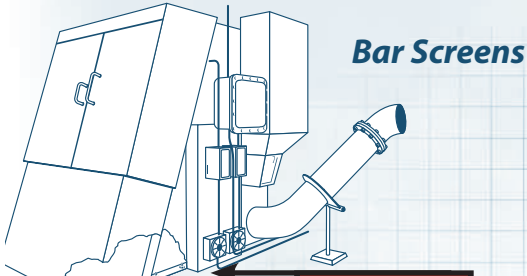

Bar Screens

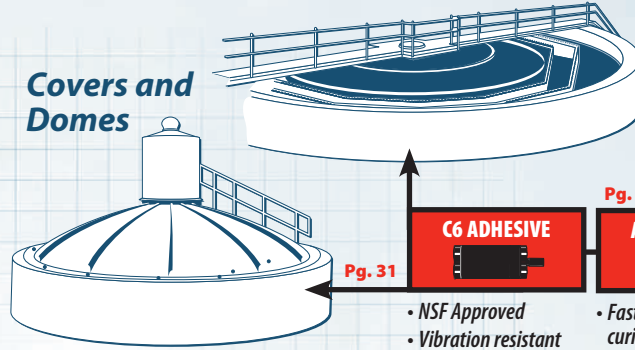

Covers and Domes

Pg. 22 **A7 ADHESIVE**

- Fast dispensing, fast curing adhesive
- Works with epoxy coated dowels
- NSF Approved

Pg. 31 **C6 ADHESIVE**

- NSF Approved
- Vibration resistant
- Corrosion resistant

Pg. 31 **C6 ADHESIVE**

- NSF Approved
- Vibration resistant
- Corrosion resistant

Pg. 20 **A7 ADHESIVE**

- Fast dispensing, fast curing adhesive
- Works with epoxy coated dowels

Railings and Ladders

Instrumentation and Controls

Pg. 54 **TRUBOLT**

- Multiple head styles
- Heavy duty
- 360° hole contact
- 304 and 316 stainless steel

Pg. 60 **TRUBOLT +**

- 2006 IBC & 2009 IBC Compliant
- All seismic zone and cracked concrete approved
- Thru fixture fastening

Pg. 31 **C6 ADHESIVE**

- NSF Approved
- Vibration resistant
- Corrosion resistant

Pg. 54 **TRUBOLT**

- Multiple head styles
- Heavy duty
- 360° hole contact
- 304 and 316 stainless steel

Pg. 60 **TRUBOLT +**

- 2006 IBC & 2009 IBC Compliant
- All seismic zone and cracked concrete approved
- Thru fixture fastening

Pipe Supports

- Special 3/8" version for prestressed concrete
- Available in 1/4" thru 3/4" internal diameters
- Stainless steel available

Pg. 60 **TRUBOLT +**

- 2006 IBC & 2009 IBC Compliant
- All seismic zone and cracked concrete approved
- Thru fixture fastening

Pg. 67 **MULTI-SET**

Pg. 54 **TRUBOLT**

- Multiple head styles
- Heavy duty
- 360° hole contact
- 304 and 316 stainless steel

Conveyors

Pg. 54 **TRUBOLT**

- Fully threaded for maximum versatility
- Available in 304, 316 stainless steel, and galvanized steel

Pg. 60 **TRUBOLT +**

- 2006 IBC & 2009 IBC Compliant
- All seismic zone and cracked concrete approved
- Thru fixture fastening

Pg. 62 **LDT**

- Finished head
- Removable
- Install by hand or with impact wrench

Diffusers

Pg. 20 **A7 ADHESIVE**

- Fast dispensing, fast curing adhesive
- Works with epoxy coated dowels
- NSF Approved

Pg. 31 **C6 ADHESIVE**

- NSF Approved
- Vibration resistant
- Corrosion resistant
- Can be installed underwater

PUMPS

Pg. 31 **C6 ADHESIVE**

- NSF Approved
- Vibration resistant
- Corrosion resistant
- Can be used in oversize holes

For seismic recognition, see ICC-ES evaluation reports.
 For installation guidelines for your application, please contact our Technical Services Department at 1-800-899-7890.

Highway & Bridge Contractor Applications

Concrete Pavement Lane Addition and Joint Repair

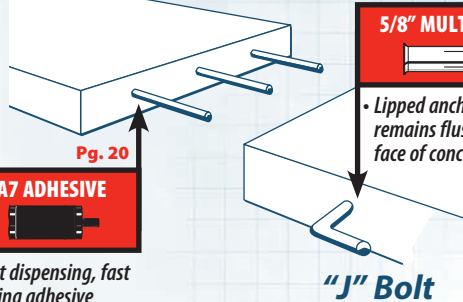

Pg. 20

A7 ADHESIVE

- Fast dispensing, fast curing adhesive
- Works with epoxy coated dowels

Pg. 67

5/8" MULTI-SET

- Lipped anchor—remains flush with face of concrete

"J" Bolt

- Can be used overhead
- Full cure in 1/2 hour at 70 degrees F

A7 ADHESIVE

Pg. 20

Bridge Mounted Signs

Down Spouts

Pg. 54

TRUBOLT

- Carbon, hot dipped galvanized, 304 or 316 stainless steel

Pg. 60

TRUBOLT +

- 2006 IBC & 2009 IBC Compliant
- All seismic zone and cracked concrete approved
- Thru fixture fastening

Suspended Conduit

Pg. 20

A7 ADHESIVE

- Fast curing
- Can be used in damp or water filled holes

Wire Loops

Rebar Doweling

Pg. 20

A7 ADHESIVE

- Fast curing
- Can be used in damp or water filled holes

Glare Screens

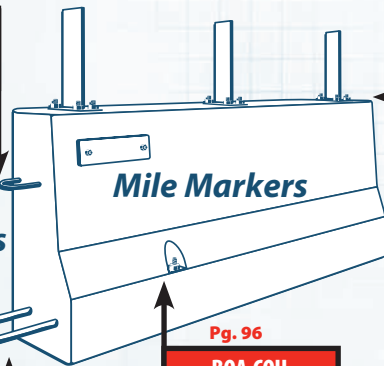

Mile Markers

Pg. 96

BOA COIL

- High shear strength
- Removable
- Reusable

Temporary Fastening of Jersey Barriers to Concrete

Pg. 62

LDT

- Finished head
- Removable
- Install by hand or with impact wrench

- Can be used in wet/damp conditions
- Fast cure
- Easy to pump

A7 ADHESIVE

Pg. 20

Guard Rail Attachments to Bridges

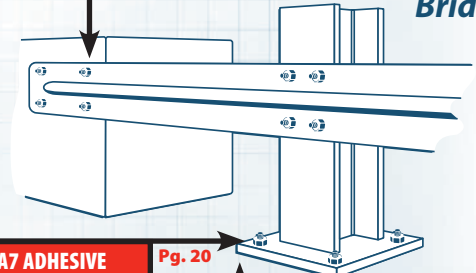

A7 ADHESIVE

Pg. 20

- Can be used in wet/damp conditions
- Fast cure
- Easy to pump

Steel Guard Rail Post Attachment to Concrete

Pg. 37

G5 ADHESIVE

- High Load Capacity
- Suitable for use close to edge of slab
- Ideal for moderate to hot climates
- Can be used for oversized holes

For seismic recognition, see ICC-ES evaluation reports.

For installation guidelines for your application, please contact our Technical Services Department at 1-800-899-7890.

Department of Transportation Approvals & Listings

For approvals contact local engineering on a per project basis.

Call your local RED HEAD sales person for more information.

ITW Red Head

Call our toll free number 800-899-7890 or visit our web site for the most current product and technical information at www.itwredhead.com

RED HEAD

General Contractor Applications

Replacement of Misplaced Anchors

Pg. 37

G5 ADHESIVE

- Ideal for hot climates—extended working time formula

Pg. 62

LDT

- ICC recognized for seismic zones

Pg. 20

A7 ADHESIVE

- Damp holes or underwater
- Fastest cure (35 min. at 60°F)
- Dispenses and cures faster in cold weather

Cast-In-Place Bolt in Wrong Location

Tilt Wall Anchorage

Pg. 96

BOA COIL

- High shear strength
- Removable
- Reusable

Pg. 54

TRUBOLT

- Available in 3/4" x 7"
- Drill hole deeper than anchor length, drive into hole after use

Pg. 60

TRUBOLT +

- 2006 IBC & 2009 IBC Compliant
- All seismic zone and cracked concrete approved
- Thru fixture fastening

Seismic Hold Downs

Pg. 20

A7 ADHESIVE

- Damp holes or underwater
- Fastest cure (35 min. at 60°F)
- Dispenses and cures faster in cold weather

Pg. 37

G5 ADHESIVE

- High Load Capacity
- Suitable for use close to edge of slab
- Ideal for moderate to hot climates
- Can be used for oversized holes

Replacement of Damaged Anchors

Pg. 20

A7 ADHESIVE

- Damp holes or underwater
- Fastest cure (35 min. at 60°F)
- Dispenses and cures faster in cold weather

Pg. 31

C6 ADHESIVE

- NSF Approved
- Vibration resistant
- Corrosion resistant
- Can be used in oversize holes

Pg. 37

G5 ADHESIVE

- Extended working time—ideal for warm to hot climates
- Can be used in oversize holes

Damaged Cast-In-Place Anchor

For seismic recognition, see ICC-ES evaluation reports.

For installation guidelines for your application, please contact our Technical Services Department at 1-800-899-7890.

Material Handling Applications

Overhead Doors

Pg. 97

PRIMA



- Removable
- Finished head
- Works in solid concrete, hollow block and brick

Pg. 62

LDT



- Hand installation
- block or concrete

Pg. 20

A7 ADHESIVE WITH UMBRELLA



- High load in hollow block or concrete

Shelving

- Removable
- Easy to install
- Single piece design

Pg. 62

LDT



Pg. 54

TRUBOLT WEDGE



- Thru fixture fastening
- Available in hot-dipped galvanized steel

Pg. 60

TRUBOLT +



- 2006 IBC & 2009 IBC Compliant
- All seismic zone and cracked concrete approved
- Thru fixture fastening

Rails

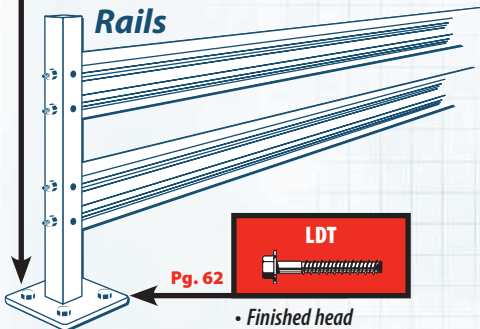

Pg. 62

LDT



- Finished head
- Removable
- Installs with impact wrench

Conveyors

Pg. 62

LDT



- Finished head
- Removable
- Installs with impact wrench
- Single piece design

Pg. 54

TRUBOLT WEDGE



- Thru fixture fastening
- Installs fast with no spotting of holes

Pg. 60

TRUBOLT +



- 2006 IBC & 2009 IBC Compliant
- All seismic zone and cracked concrete approved
- Thru fixture fastening

- NSF Approved
- Vibration resistant
- Corrosion resistant
- Can be used in oversize holes

Pg. 31

C6 ADHESIVE



Pg. 62

LDT



- Finished head
- Removable
- Now available with corrosion resistance

Pg. 20

A7 ADHESIVE



- Fast curing
- Impact resistant
- Non-sag formula

Pg. 37

G5 ADHESIVE



- Extended working time—ideal for warm to hot climates
- Can be used in oversize holes

Dock Bumpers

- 2006 IBC & 2009 IBC Compliant
- All seismic zone and cracked concrete approved
- Thru fixture fastening

Pg. 60

TRUBOLT +



Pg. 54

TRUBOLT WEDGE



- Thru fixture fastening
- Installs fast with no spotting of holes

Racks

- Finished head
- Removable
- Installs with impact wrench
- Single piece design

For seismic recognition, see ICC-ES evaluation reports.

For installation guidelines for your application, please contact our Technical Services Department at 1-800-899-7890.

ITW Red Head

Call our toll free number 800-899-7890 or visit our web site for the most current product and technical information at www.itwredhead.com

RED HEAD

Specialty Applications

Stadium Seating

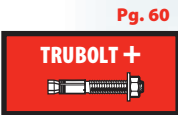
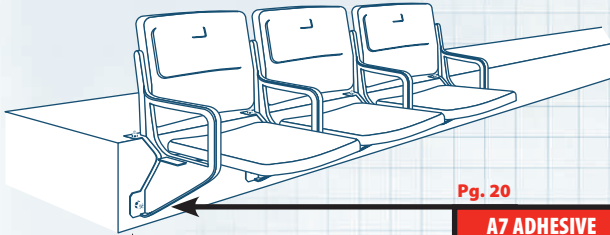

Pg. 60

- 2006 IBC & 2009 IBC Compliant
- All seismic zone and cracked concrete approved
- Thru fixture fastening

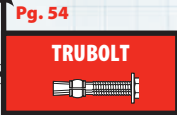

Pg. 54

- Corrosion resistant
- Normal weight or lightweight concrete
- Used in major stadiums across the country
- Immediate loading

Pg. 20



- Corrosion resistant
- Normal weight or lightweight concrete
- Used in major stadiums across the country

Basement Wrap

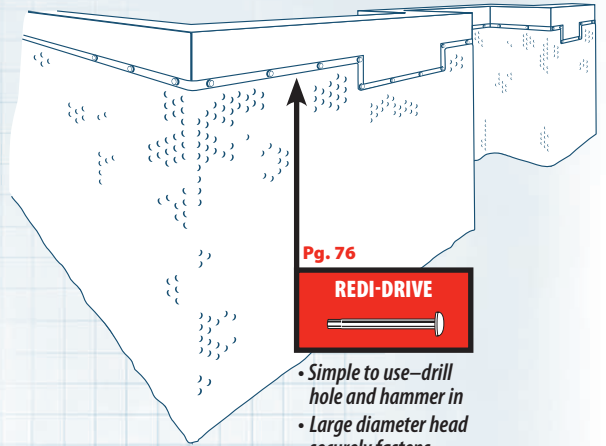

Pg. 76



- Simple to use—drill hole and hammer in
- Large diameter head securely fastens basement wrap

Expansion Joints

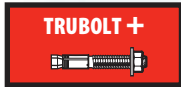

Pg. 60

- 2006 IBC & 2009 IBC Compliant
- All seismic zone and cracked concrete approved
- Thru fixture fastening



Pg. 54

- High load capacity
- Fast installation

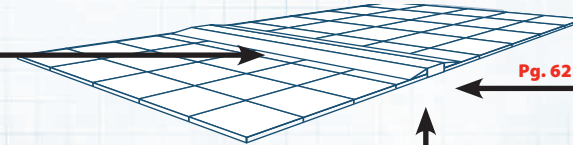

Pg. 62



- Finished head
- Removable
- Installs by hand or with impact wrench

Pg. 37



- High load capacity
- Suitable for use close to edge of slab

Flooring Systems

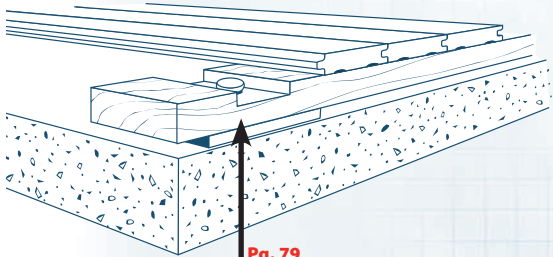

Pg. 79



- Simple to use—drill hole and hammer in
- Setting tool available for tight locations

Underwater Installation

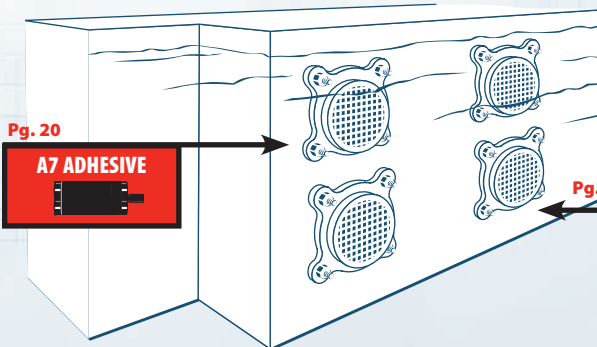

Pg. 20



Pg. 54

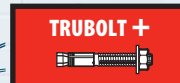

Pg. 60



- 2006 IBC & 2009 IBC Compliant
- All seismic zone and cracked concrete approved
- Thru fixture fastening
- Vibration resistant
- Corrosion resistant
- Available in 316 stainless steel

For seismic recognition, see ICC-ES evaluation reports.

For installation guidelines for your application, please contact our Technical Services Department at 1-800-899-7890.