

National Gypsum Construction Guide



HOW TO USE THE NATIONAL GYPSUM COMPANY GYPSUM CONSTRUCTION GUIDE

NATIONAL GYPSUM PRODUCTS FOR ALL YOUR BUILDING NEEDS

Your National Gypsum Company "Gypsum Construction Guide" has been carefully developed to provide you with a comprehensive guide to the entire range of National Gypsum products. We have attempted to give you the most accurate, up-to-date information in a clear, concise, easy-to-read format. Because it is important for us to ensure our guide is user-friendly, we welcome your comments. Please write us at: National Gypsum Company Technical Services Department, 2001 Rexford Road, Charlotte, N.C. 28211 or call 1-800-NATIONAL (1-800-628-4662) U.S.A. or Canada.

For your easy reference and accessibility to this information, we have placed all of our Sweet's material in this section. For a complete copy of our literature call 1-800-NATIONAL.

CAD DRAWINGS AND SPECIFICATIONS

To assist you in your design process, all CAD drawings and specifications are available at www.nationalgypsum.com. Computer aided design (CAD) drawings are in DXF, DWG and GIF file formats. Specifications are in CSI three-part format and CSI page format. Additional specification options are provided in Masterspec and Manu-Spec.

TRADEMARKS

The following names are trademarks owned by National Gypsum Company or its subsidiary, National Gypsum Properties, LLC:

- DURABASE®
- DURASAN®
- EASY FINISH®
- EDGE GRIP™
- EXCELLENCE ACROSS THE BOARD®
- e²XP™
- E-Z STRIP®
- FIRE-SHIELD®
- FIRE-SHIELD C™
- GOLD BOND®
- GOLD BOND 54®
- GRIDMARX®
- GRIDSTONE®
- GYPSOLITE®
- HIGH FLEX®
- HI-ABUSE®
- HI-IMPACT®
- KAL-KORE®
- KAL-KORNER BEAD®
- KAL-KOTE®
- KAL-MESH®
- MULTI-FLEX®
- NGC®
- 1-800 NATIONAL®
- PERFECT SPRAY®
- PERMABASE®
- PERMABASE FLEX®
- PROFORM®
- SEASPRAY MVR®
- SHAFTLINER®
- SHAFTLINER XP®
- SOUNDBREAK™
- STA-SMOOTH®
- TRIPLE-T®
- ULTRA™
- UNI-KAL®
- X-KALIBUR®
- XP®

SUB-SECTION HEADING

Each product in the section will be designated with a sub-section heading on the appropriate pages.

COLOR ARROW HEAD

Indicates next topic for a product, i.e. Description, Technical Data, Details, Specifications, Recommendations, Installation.

Suspended Metal Lath Ceilings

DESCRIPTION

Metal lath suspensions are commonly made below virtually all types of construction for fire-rated and non fire-rated plaster ceilings. Framing of 1 1/2" C.R. channels are spaced up to 4' o.c., perpendicular to joists and are cross-furred with 3/4" C.R. channels spaced according to specifications for types and weight of metal lath. Lath is then properly lapped at sides and ends and tied every 6" to the 3/4" channel.

Where it is advisable to install unrestrained ceilings, having perimeters separated from adjacent walls or partitions, galvanized casing beads

should be installed around the periphery. Metal Lath is frequently used for furred as well as suspended ceilings. Metal lath is used for furring from wood, concrete and steel joists.

RECOMMENDATIONS

- Control joints should be installed in ceilings without perimeter relief with a maximum distance between such joints of 30' with a maximum undivided area of 900 sq. ft. With perimeter relief, maximum distance is 50' with maximum undivided area of 2500 sq. ft.
- Use three-coat plastering on metal lath.

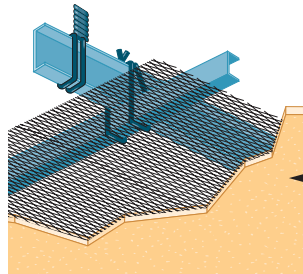

TECHNICAL DATA

SIZE AND SPACING OF CHANNEL FOR SUSPENDED CEILINGS

Center to Center Spacing of Hangers Along Channel	Size of Cold Rolled Channel	Main Channel (weight per 1000 ft.) (305 M)	Maximum Center to Center Spacing of Channel
up to 3' (914 mm)	1 1/2" (38.1 mm)	475 lbs. (216 kg)	4' (1219 mm)
up to 36" (1067 mm)	1 1/2" (38.1 mm)	475 lbs. (216 kg)	3'6" (1067 mm)
up to 4' (1219 mm)	1 1/2" (38.1 mm)	475 lbs. (216 kg)	3' (914 mm)

SIZE AND SPACING OF CHANNEL FOR FURRED AND SUSPENDED CEILINGS

Center to Center Spacing of Hangers	3/4" (19.0 mm) C.R. Channel Cross Furring 300 lbs. (136 kg)/1000 ft. (305 M)	Maximum Furring Spacing
up to 3' (914 mm)	3/8" (9.5 mm) rib lath	24" (610 mm)
up to 3' (914 mm)	3/4 lb. (1.5 kg) flat rib lath	19" (483 mm)
up to 3'6" (1067 mm)	3/4 lb. (1.5 kg) mesh lath	16" (406 mm)
up to 4' (1219 mm)	2.5 lb. (1.1 kg) mesh lath	12" (305 mm)

MAXIMUM SPACING OF SUPPORTS FOR METAL LATH

Type of Lath	Support Spacing	Weight of Lath lbs. per sq. yd. (kg/m ²)
Diamond Mesh (flat expanded)	16" (406 mm)	3.4 (1.9)
Flat Rib	16" (406 mm)	2.75 (1.5)
	19" (483 mm)	3.4 (1.9)
3/8" (9.5 mm) Rib	24" (610 mm)	3.4 (1.9)

DETAILS

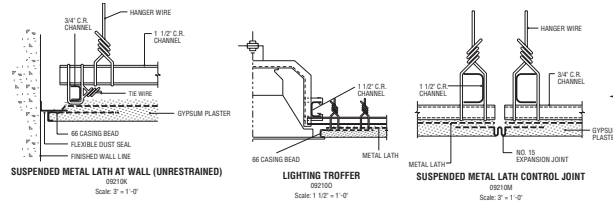

GRAPHICS, ILLUSTRATIONS AND PHOTOGRAPHY

Each product grouping is full of informative graphics and photography as a visual aid in identifying products, uses and installation.

CAD DRAWINGS

These drawings are included where appropriate to assist architects and specifiers with detailed drawings.

PAGE NUMBER



National Gypsum Company Headquarters
2001 Rexford Road
Charlotte, North Carolina 28211
(704) 365-7300
Internet - www.nationalgypsum.com
COPYRIGHT 2008 NATIONAL GYPSUM COMPANY

SUB-SECTION NAME
Repeats the name of the current sub-section.

CAD DRAWING FILE NUMBER



Charlotte, North Carolina, is the home of the new National Gypsum Company.

▶ TABLE OF CONTENTS

Product Specification Directory3

Sound and Fire Rated Assemblies8

Quick Selector for Fire and Sound Rated Systems.....9

 Gypsum Plaster Partitions – Metal Lath.....11

 Plaster Fireproofing Columns (10WF40 or heavier).....12

 Plaster Fireproofing Beams (8WF24 or heavier)12

 Veneer Plaster Partitions – Wood and Steel Framing.....12

 Gypsum Board Partitions – Wood Framing (Load-Bearing)12

 Gypsum Board Partitions – Steel Framing.....14

 Gypsum Board Partitions – Steel Framing (Load-Bearing)18

 Gypsum Board Partitions – Durasan Prefinished Gypsum Board.....18

 Gypsum Board Partitions – Solid.....19

 Gypsum Board Partitions – Shaftwalls, Area Sep. Walls.....20

 Gypsum Board Column Fireproofing.....21

 Gypsum Board Beam Fireproofing22

 Gypsum Board Floor/Ceilings – Wood Framing.....22

 Gypsum Board Roof/Ceilings – Wood Framing23

 Gypsum Board Floor/Ceilings – Steel Framing24

 Gypsum Board Roof/Ceilings – Steel Framing.....26

 Gypsum Board Horizontal Shaftwall Duct Protection.....26

06 16 43 Gold Bond® BRAND Gypsum Sheathing and e-XP Extended Exposure Sheathing27

09 23 00 Conventional Plaster Systems.....33

09 26 13 Veneer Plaster Systems43

09 29 00 Gypsum Board Systems57

09 29 00 Gold Bond® BRAND GridMarX® Gypsum Board64

09 29 00 Gold Bond® BRAND Gypsum Board65

09 29 00 Gold Bond® BRAND Fire-Shield® Gypsum Board66

09 29 00 Gold Bond® BRAND Sta-Smooth Gypsum Board67

09 29 00 Gold Bond® BRAND XP® Gypsum Board70

09 29 00 Gold Bond® BRAND Exterior Soffit Board.....71

09 29 00 Gold Bond® BRAND 1" Fire-Shield® Shaftliner.....73

09 29 00 Gold Bond® BRAND 1" Fire-Shield® Shaftliner XP®.....74

09 29 00 High Flex BRAND Gypsum Board.....75

09 29 00 Gold Bond® BRAND High Strength Ceiling Board.....77

09 29 00 Gold Bond® BRAND Hi-Abuse® XP® Gypsum Board78

National Gypsum Company is a fully integrated manufacturer and supplier of building and construction products worldwide.

Our primary emphasis is on Gold Bond® BRAND gypsum board, ProForm® BRAND joint treatment products, PermaBase® BRAND cement board, and gypsum plaster systems.

Based in Charlotte, NC, the privately held National Gypsum Company operates more than 40 facilities throughout the U.S. and Canada.

09 29 00 Hi-Impact® BRAND XP® Gypsum Board.....81

09 29 00 SoundBreak™ Gypsum Board84

09 29 00 Gridstone BRAND Ceiling Panels.....86

09 29 00 Gridstone BRAND Cleanroom Ceiling Panels87

09 29 00 Gridstone® BRAND Hi-Strength Ceiling Panels88

09 29 00 Gold Bond® BRAND Foil Back Gypsum Board89

09 29 00 Gypsum Systems Nonload-Bearing Steel Frame Partitions90

09 29 00 Drywall Metal Framing93

09 29 00 Accessories94

09 29 00 Steel Frame Ceilings/Furring Channels or Studs.....99

09 29 00 Wood Frame Walls and Ceilings101

09 29 00 Resilient Furring Channel Construction106

09 29 00 Gypsum Board Over Masonry108

09 29 00 Solid Laminated Partitions.....110

09 29 00 ProForm® BRAND Joint Treatment112

09 29 00 ProForm® BRAND Texture Products115

09 29 00 Levels of Gypsum Board Finish.....118

09 21 16.23 Cavity Shaftwall Systems.....123

09 21 16.23 Horizontal Shaftwall Duct and Ceiling Assemblies.....137

09 21 16.33 H-Stud Area Separation Wall System139

09 28 00 PermaBase® BRAND Cement Board.....145

INDEX Index157

INDEX Index of CAD Detail Drawings.....161

Our vision: To be recognized as the industry leader for extraordinary service and products that consistently meet our customers' toughest standards.

Driving and sustaining our Vision are these core Values:

- Customer satisfaction as our priority
- Honesty, integrity, fairness and respect
- Communications and openness with all those with whom we deal
- Teamwork, empowerment and continuous improvement
- Work hard, be safe, and have fun

NATIONAL GYPSUM COMPANY



National Gypsum's Technology Innovation Center is located in Charlotte, North Carolina. National Gypsum has always held a leadership role in the development of gypsum based products and systems. Many of today's most innovative gypsum, joint treatment and cement board products and systems were developed, tested and introduced by National Gypsum Company.

YOUR TECHNICAL RESOURCE

Today, more than ever, clear, accurate information is vital to every construction job. The challenges of construction continue to grow: increasingly innovative building designs, tighter budgets, tighter schedules, and the continuing development of new materials and construction techniques.

A NETWORK OF TECHNICAL SUPPORT

In keeping with the corporate mission to become the preferred supplier for our customers, National Gypsum has made a total commitment to technical assistance and created a network of support to provide valuable assistance at every stage of a project's development.

Field Representation. Before construction begins, while plans and specifications are being produced, these experienced, trained professionals provide technical consultation in selecting, specifying and using gypsum-based building materials.

During the construction phase, our Field Representatives have the experience and the training to assure that the National

Gypsum products you need and specify are right for the job. They are backed up by thoroughly trained Customer Service Representatives who can also help with product selection and purchase.

Continuing Research. Because the building industry and building codes are constantly changing, National Gypsum maintains a full-scale research center that continually tests and evaluates products, applications, construction systems and techniques.

Immediate Answers. Of course, there are times when you need an answer to a pressing situation or question. For this reason, National Gypsum has set up our Technical Assistance Hotline: 1-800-NATIONAL (1-800-628-4662).

One toll-free phone call gives a direct, personal link to a technical expert with up-to-date knowledge of specifications, building codes, product information and much more.

QUALITY IS SYSTEMATIC

At the National Gypsum Research Center, we concentrate not only on building products individually but also on complete construction systems. In

such systems, products are evaluated together as complete building assemblies – walls, partitions, floors and ceilings.

Before National Gypsum releases a system to the building industry, the system is thoroughly tested and the results are correlated and charted, making it easier for the builder or architect to match a system to his needs or to building codes. This extensive database of technical information is made available to you not only through technical bulletins such as this one, but also through our technical support network.

The construction systems referred to in this manual are designed and tested with material manufactured by National Gypsum.

Substitutions of other products or brands for National Gypsum Products are not recommended.

Field Installation of tested systems must be identical to the laboratory installation to produce optimum performance of these systems, though duplication of controlled, laboratory results in such field installations is not guaranteed.



National Gypsum's own patented Calcidyne system heats the land plaster to remove 75% of the water which is chemically combined in the gypsum molecules.

Performance tests are conducted according to accepted national standards under controlled laboratory conditions to minimize variances and to permit comparison of test results of all types of systems, similar and dissimilar.

Detailed recommendations are contained in each section. Architects, structural engineers or others who are responsible for field installations must make their own determinations concerning the applicability of the laboratory performance test results to the design or construction of any specific structure.



National testing organizations frequently participate in the many product tests conducted at NGC Testing Services. Fire, acoustical, structural and analytical test laboratories are available commercially through NGC Testing ServicesSM for other manufacturers and research interests. For information, call 716-873-9750 or www.NGCTestingServices.com.

FOREWORD

This directory is designed to provide a convenient, up-to-date reference to some of the products marketed by National Gypsum Company, and to the ASTM and Federal Specifications with which they comply.

The General Services Administration has cancelled many Federal procurement documents. These have been superseded by ASTM Specifications. Federal Specifications are listed for reference.

For the key to Federal Specification, gypsum board and joint treatment product designations (Type, Form, etc.), refer to table on page 7.

This is to certify that the following materials comply in all respects with listed specifications.

GYPSON BOARD PRODUCTS

Specification Standards

	Product	Description and Use	Specification Standards	
			ASTM	Federal
Gypsum Board	Regular Gypsum Board or Sta-Smooth	Fire resistant. Will take decoration after proper surface preparation of interior walls and ceilings.	C 1396	SS-L-30D Type III
	XP Gypsum Board	1/2" (12.7 mm) gypsum board with a moisture resistant gypsum core and mold/mildew resistant purple paper. Will take decoration after proper surface preparation of interior walls and ceilings.	C 1396	SS-L-30D Type III
	Fire-Shield Gypsum Board (Includes "C")	1/2" (12.7 mm) and 5/8" (15.9 mm) gypsum board with specially processed core highly resistant to fire; type X core.	C 1396 Type X	SS-L-30D Type III Grade X
	XP Fire-Shield Gypsum Board (Includes "C")	1/2" (12.7 mm) and 5/8" (15.9 mm) gypsum board with a moisture resistant gypsum core highly resistant to fire and mold/mildew resistant purple paper; type X core.	C 1396 Type X	SS-L-30D Type III Grade X
	SoundBreak Gypsum Board	5/8" (15.9 mm) acoustically enhanced gypsum board used in construction of high rated STC assemblies.	C 1396	SS-L-30D Type III
	Foil Back Gypsum Board	Standard gypsum board with aluminum foil on backside providing vapor retarder for interior walls and ceilings.	C 1396	SS-L-30D Type III Form C
	Fire-Shield Shaftliner (Includes XP)	1" (25.4 mm) thick, 2' (610 mm) wide, for solid partitions, shaft walls and Area Separation Walls; type X core.	C 1396 Type X	SS-L-30D Type IV Grade X
	Regular or Fire-Shield Exterior Soffit Board	Gypsum board with extra resistance to moisture and sagging used for exterior soffit.	C 1396 Type X	None
	Durasan Prefinished Regular Gypsum Board	Gypsum board with a vinyl surface, combines texture and pattern in colors. No decoration required.	C 1396	SS-L-30D Type III Class 3
	Durasan Prefinished Fire-Shield Gypsum Board	Gypsum board with a vinyl surface, combines texture and pattern in colors; type X core.	C 1396 Type X	SS-L-30D Type III Grade X Class 3
	High Flex Gypsum Board	1/4" (6.4 mm) flexible gypsum board designed for use in radius wall and ceiling construction.	C 1396	SS-L-30D Type III
	High Strength Ceiling Board	1/2" (12.7 mm) gypsum board with core formulated to provide increased sag resistance.	C 1396	SS-L-30D Type III
	Hi-Abuse XP Fire-Shield Gypsum Board	5/8" (15.9 mm) gypsum board with heavy abrasion resistant mold/mildew resistant purple paper and a special core to provide greater resistance to surface indentation; type X core.	C 1396 Type X	SS-L-30D Type III Grade X
	Hi-Impact XP Fire-Shield Gypsum Board	5/8" (15.9 mm) gypsum board with heavy abrasion resistant mold/mildew resistant purple paper and a special moisture resistant gypsum core backed with reinforcing fiber glass mesh; type X core.	C 1396 Type X	SS-L-30D Type III Grade X
	Gridstone Ceiling Panels	1/2" x 2' x 2' (12.7 mm x 610 mm x 610 mm) 1/2" x 2' x 4' (12.7 mm x 610 mm x 1219 mm) grid panels with Fire-Shield G type X core and vinyl laminate.	C 1396 Type X, Class 1; E 1264, Type XX, Patterns E, G	None

GYPSUM BOARD PRODUCTS (cont.)		Description and Use	ASTM	Federal
Gypsum Board	Gridstone Hi-Strength Ceiling Panels	5/16" x 2' x 2' (7.9 mm x 610mm x 610 mm) 5/16" x 2' x 4' (7.9 mm x 610 mm x 1219 mm) grid panels with non-combustible gypsum core and vinyl laminate.	C 1396 Class 1	None
	Gridstone CleanRoom Ceiling Panels	1/2" x 2' x 2' (12.7 mm x 610 mm x 610mm) 1/2" x 2' x 4' (12.7 mm x 610 mm x 1219 mm) grid panels with Fire-Shield G type x core and vinyl laminate. Completely sealed on face, back and edges.	C 1396 Type X, Class 1; E 1264, Type XX, Patterns E, G	None
	Durabase Gypsum Board	5/16" (7.9 mm), 3/8" (9.5 mm), 1/2" (12.7 mm), and 5/8" (15.9 mm) gypsum board for printing application or laminating base.	C 1396	None
	Regular Jumbo Gypsum Sheathing	1/2" (12.7 mm) gypsum board to be used as a sheathing for exterior wall construction.	C 1396	SS-L-30D Type II
	Fire-Shield Jumbo Gypsum Sheathing Sheathing	5/8" (15.9 mm) gypsum board to be used as sheathing for fire rated exterior wall construction; type X core.	C1396 Type X	SS-L-30D Type II Grade X
	e²XP Extended Exposure Sheathing	1/2" (12.7 mm) Regular with a coated fiberglass mat used as a sheathing for exterior wall construction.	C1177 and applicable sections of C1396	SS-L0-30D Type II
	e²XP Extended Exposure Sheathing	5/8" (15.9 mm) Type X with a coated fiberglass mat used as a sheathing for fire-rated exterior wall construction	C1177 and applicable sections of C1396	SS-L0-30D Type II Grade X

LATH, DRYWALL JOINT TREATMENT, TEXTURES AND ACCESSORIES **Specification Standards**

	Product	Description and Use	ASTM	Federal
Lath	Kal-Kore Plaster Base	3/8" (9.5 mm), 1/2" (12.7 mm) gypsum base for veneer plaster systems.	C 1396	SS-L-30D Type VI
	Kal-Kore Fire-Shield Plaster Base (includes "C")	1/2" (12.7 mm), 5/8" (15.9 mm) gypsum base for veneer plaster systems; type X core.	C 1396 Type X	SS-L-30D Type VI Grade X
	Regular or Fire-Shield Hi-Abuse Kal-Kore Plaster Base	Gypsum base with special core to provide greater resistance to surface indentation. Designed for high abuse areas.	C 1396 Type X	SS-L-30D TypeVI Grade X
Joint Treatment	ProForm All Purpose Joint Compound	A conventional full-weight ready mix joint compound used for all phases of drywall finishing.	C 475	SS-J-570B
	ProForm XP Joint Compound	A conventional full-weight ready mix joint compound formulated for additional mold resistance.	C 475	SS-J-570B
	ProForm Multi-Use Joint Compound	A ready mix compound that combines the best attributes of All Purpose and Lite for use in all phases of drywall finishing	C 475	SS-J-570B
	ProForm Lite Joint Compound	A full "Lite" weight ready mix for use in finishing gypsum board, gypsum board joints, spotting fasteners and finishing accessories.	C 475	SS-J-570B
	ProForm Ultra Joint Compound	An all purpose joint compound that pulls and sands easier than conventional ready mix with up to 50% less shrinkage.	C 475	SS-J-570B
	ProForm Taping Joint Compound	Ready mixed joint compound used to enhance bond when embedding joint tape and applying cornerbeads and accessories.	C 475	SS-J-570B
	ProForm Topping Joint Compound	Ready mixed topping compound designed as a finish coat over joint compound.	C 475	SS-J-570B
	ProForm Texture Grade	A nonaggregated, ready mixed material formulated for texturing interior walls and ceilings.	C 475	SS-J-570B
	ProForm Triple-T Compound	Triple-T is an all-purpose powder product to be job mixed with water. It is recommended for tape application, finishing and texturing.	C 475	SS-J-570B
	ProForm Sta-Smooth, Sta-Smooth Lite, and Sta-Smooth HS Joint Compounds	A setting type powder compound used for joint finishing.	C 475	SS-J-570B

LATH, DRYWALL JOINT TREATMENT, TEXTURES AND ACCESSORIES (cont.)			Specification Standards	
	Product	Description and Use	ASTM	Federal
Textures	ProForm Perfect Spray Textures	A white, aggregated spray texture for interior use on walls and ceilings.	None	None
	ProForm Perfect Spray EM Textures	A white, nonaggregated spray texture for interior use on walls and ceilings.	None	None
Accessories	Gypsum Board Cornerbead*	Used to protect exterior corners.	C 1047	None
	Gypsum Board Casing Bead*	Used to reinforce and trim around doors and windows.	C 1047	None
	Arch Cornerbead*	Used straight for exterior corners or may be snapped and bent to form arches.	C 1047	None
	ProForm Joint Tape	A paper tape for concealment of gypsum board joints.	C 475**	SS-J-570B**
	ProForm Fiberglass Mesh Tape	A self-adhering glass fiber mesh tape to be used only with setting compounds.	C 475	None
	ProForm Multi-Flex Tape Bead	Used to form inside or outside corners that are less or greater than 90°.	None	None
	E-Z Strip Expansion Joint*	Vinyl extrusion used as an expansion or control joint for drywall and veneer plaster walls and ceilings.	C 1047	None
	.093 Zinc Expansion Joint*	All zinc part used as an expansion or control joint for drywall and veneer plaster walls and ceilings.	C 1047	None

*National Gypsum does not manufacture these products.

FIRE AND SMOKE STOP COMPOUND			Specification Standards	
	Product	Description and Use	ASTM	Federal
	ProForm Sta-Smooth FS 90 Compound	Setting type product formulated to provide protection in fire stopping applications through gypsum and other fire rated assemblies. Meets ASTM E 814 and ANSI/UL 1479.	None	None

PLASTER PRODUCTS AND ADDITIVES			Specification Standards	
	Product	Description and Use	ASTM	Federal
Basecoat Plasters	Gold Bond Two-Way Hardwall Gypsum Plaster	For use with job-mixed aggregate. Machine spray or trowel application.	C 28	SS-P-00402B Type II
	Gold Bond Gypsolite Plaster	Mill-mixed with perlite. Add only water on the job.	C 28	SS-P-00402B Type I
	Kal-Kote Base Plaster	Basecoat plaster for veneer system. Add only water on the job.	C 587	SS-P-00402B Type VI
Finish Plasters	Gold Bond Gypsum Gauging Plaster	Used with lime for trowel finish or run-in-place ornamental work.	C 28	SS-P-00402B Type V
	Gold Bond Gypsum Moulding Plaster	Used with lime for run-in-place ornamental work or with water only for precast ornaments.	C 59	SS-P-00402B Type V
	Kal-Kote Smooth Finish Plaster	Hard, thin, smooth finish over Kal-Kote base plaster or conventional basecoat plasters.	C 587	SS-P-00402B Type VI
	Kal-Kote Texture Finish Plaster	Hard, thin, textured finish over Kal-Kote base plaster or conventional basecoat plasters.	C 587	SS-P-00402B Type VI
	Uni-Kal Veneer Plaster	One coat finish over Kal-Kote. Can also be used as finish over Kal-Kote base or conventional plaster.	C 587	SS-P-00402B Type VI
	X-KALibur Veneer Plaster	Extended set time, one coat finish over Kal-Kote. Can also be used as finish over Kal-Kote base or conventional basecoat plasters.	C 587	SS-P-00402B Type VI
Special Additives	Gold Bond Retarder	A powder used to slow the set of gypsum plaster.	None	None
	Gold Bond Accelerator	A powder used to quicken the set of gypsum plaster.	None	None

**Paper tape meeting these specifications available on special order.

VENEER PLASTER ACCESSORIES		Specification Standards	
Product	Description and Use	ASTM	Federal
Kal-Korner Bead*	Used to protect exterior corners in veneer plaster systems.	C 1047	None
Expanded Veneer Cornerbead*	Used as an alternate to the Kal-Korner bead for exterior corners.	C 1047	None
Veneer J Trim Casing Bead*	Used as a finished edge at door and window jambs.	C 1047	None
Veneer L Trim Casing Bead*	Used as a finished edge at door and window jambs.	C 1047	None
Kal-Mesh Tape	A coated non-adhesive fiberglass tape which is stapled to Kal-Kore to reinforce all joints and interior angles.	C 475	None

*National Gypsum does not manufacture these products.

CEMENT BACKERBOARDS		Specification Standards	
Product	Description and Use	ASTM	Federal
PermaBase* Cement Board	Lightweight cement board composed of portland cement, aggregates and glass fiber mesh reinforcement, 1/4" (6.3 mm) (counters/floors only), 1/2" (12.7 mm) and 5/8" (15.9 mm) thickness, 32" (813 mm), 36" (914 mm), and 48" (1219 mm) widths, 48" (1219 mm), 60" (1524 mm), 72" (1829 mm) and 96" (2438 mm) lengths. For interior or exterior use. May be used on exterior surfaces with imposed wind loads up to 40 PSF.	C 1325	None
PermaBase Flex* Cement Board	Lightweight Polymer-modified cement board with glass fiber mesh reinforcement, 1/2" (12.7 mm) thick, 48" (1219 mm) width, 96" (2438 mm) length. For use anywhere an even curved surface is required.	None	None

*Complies with ANSI A118.9

ASTM APPLICATION SPECIFICATIONS

Used in conjunction with ASTM Product Specifications

C 754	Standard Specification for Installation of Steel Framing Members to Receive Screw-Attached Gypsum Panel Products.
C 840	Standard Specification for Application and Finishing of Gypsum Board.
C 841	Standard Specification for Installation of Interior Lathing and Furring.
C 842	Standard Specification for Application of Interior Gypsum Plaster.
C 843	Standard Specification for Application of Gypsum Veneer Plaster.
C 844	Standard Specification for Application of Gypsum Base to Receive Gypsum Veneer Plaster.
C 919	Standard Practice for Use of Sealants in Acoustical Applications.
C 1280	Standard Specification for Application of Gypsum Sheathing Board.

ANSI APPLICATION SPECIFICATIONS

Used in conjunction with ANSI Product Specifications

A 108.11	Standard for Interior Installation of Cementitious Backer Units.
----------	--

Code Report References

- [ICC ESR-1338](#)
Gypsum Wall and Ceiling Assemblies and Gypsum Board Interior and Exterior Applications
- [ICBO ES, Inc. ER-1352](#)
Gold Bond Gypsum Board - Wood Framing
- [ICBO ES, Inc. ER-1601](#)
Gold Bond Screw Steel Studs and Furring Channels
- [ICBO ES, Inc. ER-3579](#)
One and Two Hour Fire-Rated Gold Bond Interior Partition Systems
- [ICBO ES, Inc. ER-5731](#)
PermaBase Cement Board
- [ICBO ES, Inc. ER-5733](#)
Half-Inch Gold Bond High-Strength Ceiling Board
- [ICC ES, Inc. Legacy Report 90-26.01](#)
Gold Bond Fire Wall/Party Wall
- [ICC ES, Inc. Legacy Report 89-35.01](#)
Gold Bond I-Stud Cavity Shaftwall System
- [ICC ES, Inc. Legacy Report 92-19](#)
Dietrich H-Stud Area Separation Wall
- [ICC ES, Inc. Legacy Report 9525B](#)
Gold Bond I-Stud Cavity Shaftwall System
- [ICC ES, Inc. Legacy Report 496](#)
Half-Inch Gold Bond High Strength Ceiling Board
- [ICC ES, Inc. Legacy Report NER-506](#)
Dietrich Shaftwall and Stairwell Fire-Resistive Assemblies
- [National Evaluation Service, Inc., Report No. NER-578](#)
PermaBase Cement Board
- [ICC ES, Inc. Legacy Report ESR-1774](#)
Weyerhaeuser Truss Ceiling Assemblies

Key to Federal Specification Designations

GYPSUM BOARD PRODUCTS

Types–Grades–Classes–Forms–Styles

Type	Grade	Class	Form	Style
TYPE I Lath	R-Regular core X-Fire-retardant core	1-Plain face	a-Plain back b-Perforated c-Foil back	1-Square edge 5-Round edge
TYPE II Sheathing	R-Regular core W-Water-resistant treated core X-Fire-retardant core	2-Water-resistant surface	a-Plain back	1-Square edge 2-V-tongue and groove edge
TYPE III Gypsum Board	R-Regular core X-Fire-retardant core	1-Plain face 3-Predecorated surface	a-Plain back c-Foil back	1-Square edge 3-Taper or recess edge 4-Featured joint edge 6-Taper, featured edge
TYPE IV Backer board	R-Regular core X-Fire-retardant core	1-Plain face	a-Plain back c-Foil back	1-Square edge 2-V-tongue and groove edge 3-Taper or recess edge
TYPE V Formboard	R-Regular core	4-Fungus-resistant surface	a-Plain back	1-Square edge
TYPE VI Veneer Plaster Base	R-Regular core X-Fire-retardant core	1-Plain face	a-Plain back c-Foil back	1-Square edge 3-Taper or recess edge 6-Taper, featured edge
TYPE VII Water-resistant Backing Board	R-Regular core W-Water-resistant treated core X-Fire-retardant core	2-Water-resistant surfaces	a-Plain back	1-Square edge 3-Taper or recess edge

As an aid in the identification of gypsum board products, above are the classifications as set forth in Federal Specification SS-L-30D.

JOINT TREATMENT PRODUCTS

Types–Styles–Classes

Type	Style	Class
TYPE I Joint Compound	1-Drying powder	A-Taping B-Topping C-All purpose
	2-Hardening powder	A-Taping B-Topping C-All purpose
	3-Drying, premixed paste	A-Taping B-Topping C-All purpose
TYPE II Joint Tape	1-Plain	

As an aid in the identification of joint treatment products, above are the classifications as set forth in Federal Specification SS-J-570B.

Sound and Fire Rated Assemblies

SOUND RATINGS

Drywall and plaster construction systems are laboratory tested to establish their sound insulation characteristics. Airborne sound insulation is reported as the Sound Transmission Class (STC), whereas impact noise, tested on floor-ceiling systems only, is reported as the Impact Insulation Class (IIC).

When selecting systems based on laboratory performance ratings, it should be clearly understood that field conditions such as flanking paths, air leaks, etc. caused by design or workmanship can reduce acoustical performance. For these reasons National Gypsum Company cannot guarantee the performance ratings of specific construction assemblies erected in the field.

To achieve maximum sound isolation from an assembly, published construction details must be followed completely. The use of non-hardening, permanent, resilient, acoustical sealant is recommended to seal off air leaks at floor, ceiling, and partition or wall intersections.

In selecting a construction system where sound isolation is important it is necessary to take into account the building's overall structural design, openings, type of occupancy, location and background noise level. The complexity of the proposed system will necessarily affect the final cost and possibly the in-place acoustical performance of the system.

The national standard for airborne sound testing, ASTM E 90, measures the sound transmission loss from 125 to 4,000 Hertz. It is measured at 16 one-third octave frequencies. The data measured in ASTM E 90 is then fitted to the STC curve as is specified in ASTM E 413. The STC should not be compared with FSTC values that are obtained from field sound transmission loss tests following ASTM E 336 procedures. The method used to determine FSTC ratings is different and cannot be

related to STC ratings achieved by ASTM Method E 90.

FIRE RESISTANCE

The term "fire-resistance" designates the ability of a laboratory-constructed assembly to contain a fire in a carefully controlled test setting for a specified period of time. Such an assembly might be a partition, a floor/ceiling, a roof/ceiling, or a protected beam or column. The degree that assemblies put together and tested under controlled laboratory conditions retard the spread of damaging heat is measured in intervals of time. For example, if a construction assembly in the laboratory adequately contains the heat for two hours and meets other requirements during the laboratory fire test, it is given a two-hour fire resistance rating.

Fire tests may be conducted at any of several recognized facilities. Partitions, floor/ceilings, roof/ceilings, beams and columns are tested in accordance with ASTM Standard E 119, Fire Tests of Building and Construction Materials. Fire-resistance ratings are based on full-scale tests under controlled conditions and are generally recognized by building code authorities and fire insurance rating bureaus.

Requirements for fire-resistance ratings are usually assigned by local building code officials based on the expected occupancy of the space. It is critical that you review plans in the bid stage to ensure that the details drawn match the referenced design numbers. If the detail drawn does not match the assembly design number as listed in the Gypsum Association Fire Resistance Design Manual, UL Fire Resistance Directory, or Factory Mutual Specification Tested Products Guide, contact the architect for a clarification.

Fire-resistant ratings represent the results of controlled laboratory tests on assemblies made of specific con-

figuration. For that reason, National Gypsum Company cannot guarantee the performance of specific construction assemblies erected in the field. When selecting construction assemblies to meet certain fire-resistance requirements, caution must be used to ensure that each component of the assembly is the one specified in the test. Further, precaution should be taken that assembly procedure is in accordance with that of the tested assembly.

For fire safety information, go to www.nationalgypsum.com.

CONTROL JOINTS AND ISOLATION DETAILS

Though most systems referred to in this manual are non-load-bearing, they need structural consideration of their ability to retain integrity over a period of time and be relatively rigid. When other elements such as doors, fixtures, cabinets, etc., are affixed or joined to a drywall or plaster system, provision must be made to ensure that these loads are adequately supported. Structural framing, completely separate from the system, may be necessary to support eccentric or heavy loads.

CONTROL JOINTS

Control joints are frequently necessary to prevent cracking in the gypsum board and plaster systems. Isolation should always be considered where structural elements such as slabs, columns, or exterior walls can bear directly on non-load-bearing partitions.

Gypsum as well as other building products and materials are subject to some form of movement induced by changes in moisture or temperature, or both. To relieve the stresses which occur as a result of such movement, control joints are required in both partitions and ceilings.

Location of control joints is the ultimate responsibility of the design professional.



Control joints prevent cracking in large areas of gypsum board.

PARTITION CONTROL JOINTS

In long expanses of partitions such as corridors, control joints should be used at least every 30'. Door and window openings create stress points in partitions and are recommended locations for control joints. Where jambs extend from floor to ceiling and are spaced not farther apart than 30', no control joints are required. When "through-wall" control joints are required in fire rated assemblies, special details are necessary which are shown on page 96. They are based on Warnock-Hersey Report WHI 651-0318.1.

CEILING CONTROL JOINTS

For large expanses of ceilings with perimeter relief, control joints must be located a maximum of 50' o.c. in either direction; without perimeter relief, 30' o.c. maximum in either direction. Control joints should be installed where framing or furring changes direction.

PERIMETER CONTROL JOINTS

Acceptable perimeter control joints in systems do not adversely affect fire or sound ratings. The use of perimeter control joints in fire-rated assemblies is described in UL Report R-4024-7-8 and Factory Mutual Report 16738.69.

REQUEST TEST COPIES BY CALLING 1-800-NATIONAL (1-800-628-4662).

QUICK SELECTOR INDEX - FIRE/SOUND

Gypsum Plaster – Metal Lath

Fire Rating	Design No.	Page
1-hr	OSU T-147	11
1-hr	OSU T-129	11
2-hr	UL U413	11
2-hr	NBS	11

Gypsum Plaster Fireproofing Columns (10WF49 or heavier)

Fire Rating	Design No.	Page
1-hr	BMS 92/40	12
2-hr	UL X402	12
3-hr	UL X402	12
4-hr	UL X402	12

Gypsum Plaster Fireproofing Beams (8WF24 or heavier)

Fire Rating	Design No.	Page
2-hr	UL R4197-1	12
3-hr	UL R4197-1	12

Veneer Plaster Partitions

Fire Rating	Design No.	Page
1-hr	U of Cal. E.S.6727	12
1-hr	U of Cal. E.S.6892	12

Gypsum Board Partitions – Wood Framing

Fire Rating	Design No.	Page
45 min.	UL U317	12
1-hr	UL U305	12
1-hr	UL U309	13
1-hr	UL U340	13
1-hr	WHI 694-0200	13
1-hr	UL U312	13
2-hr	FM WP-360	13
2-hr	UL U301	13
1-hr	WHI 651-0319	14
2-hr	UL U302	13
2-hr	UL U371	14

Gypsum Board Partitions – Steel Framing

Fire Rating	Design No.	Page
1-hr	OSU T-3296	14
1-hr	UL U420	14
1-hr	UL V401	14
1-hr	UL V438	14
1-hr	UL U451	14
1-hr	FM WP-45	15
1-hr	OSU T-1770	15
1-hr	UL U465	15
1-hr	UL V452	15
1-hr	FM WP-66	15
1-hr	FM WP-733	15

1-hr	UL U410	16
1 1/2-hr	OSU T-3240	16
2-hr	UL V449	16
2-hr	UL V438	16
2-hr	UL U420	16
2-hr	UL U412	16
2-hr	UL U411	16
2-hr	WHI 495-0236	16
2-hr	UL V452	17
2-hr	ITS/WHI J98-32931	17
3-hr	UL U435	17
3-hr	WHI 694-0084	17
3-hr	UL V438	17
4-hr	UL U435	17
4-hr	WHI 694-108.1	17
4-hr	UL V438	17

Gypsum Board Partitions – Steel Framing (load bearing)

Fire Rating	Design No.	Page
1-hr	UL U425	18
2-hr	FM WP-199	18
2-hr	UL U425	18
3-hr	UL U426	18

Gypsum Board Partitions/Durasan Prefinished Gypsum Board

Fire Rating	Design No.	Page
1-hr	FM WP-109	18
1-hr	UL U405	18
2-hr	UL U411	18

Gypsum Board Partitions/Solid

Fire Rating	Design No.	Page
1-hr	FM WP-671	19
2-hr	UL U525	19
2-hr	FM WP-668	19
2-hr	UL U505	19
2-hr	UL U529	19

Gypsum Board Partitions – Shaftwalls, Area Separation Walls

Fire Rating	Design No.	Page
1-hr	UL U499	19
1-hr	FM WP-755	19
2-hr	UL U498	19
2-hr	FM WP-545	19
2-hr	U of Cal. 75-19 ES 7407	19
2-hr	UL U429	19
2-hr	UL U497	19
2-hr	FM WP-636	19
2-hr	WHI 651-0500.05	19
2-hr	U of Cal. 75-17 ES 7408	19
2-hr	UL U428	20

QUICK SELECTOR INDEX - FIRE/ SOUND (CONT.)

2-hr	FM WP-621	20
2-hr	FM WP-612	20
4-hr	UL V451	20
2-hr	WHI 694-0200.6	20
2-hr	WHI 651-0508	20
2-hr	UL U347	20

Gypsum Board Column Fireproofing (light column)

Fire Rating	Design No.	Page
1-hr	UL X528	21
1 1/2-hr	UL X531	21
2-hr	UL X528	21

Gypsum Board Column Fireproofing (heavy column)

Fire Rating	Design No.	Page
1-hr	UL X528	21
2-hr	UL X528	21
3-hr	UL X510	21
4-hr	UL X501	21
2-hr	UL X520	21
3-hr	UL X513	21

Gypsum Board Beam Fireproofing

Fire Rating	Design No.	Page
2-hr	UL N501	22

Gypsum Board Floor/Ceiling – Wood Framing (wood joist)

Fire Rating	Design No.	Page
1-hr	UL L522	22
1-hr	UL L501	22
1-hr	UL L515	22
1-hr	FM FC-181	22
1-hr	FM FC-193	22
1-hr	FM FC-172	22
2-hr	UL L505	22

Gypsum Board Floor/Ceiling – Wood Framing (floor truss)

Fire Rating	Design No.	Page
1-hr	UL L558	23
1-hr	FM FC-442	23
1-hr	UL L528	23
1-hr	FM FC-448	23
1-hr	FM FC-214	23
2-hr	UL L538	23

Gypsum Board Roof/Ceiling – Wood Framing (pitched roof truss)

Fire Rating	Design No.	Page
1-hr	UL P533	23

Gypsum Board Floor/Ceiling – Light Gauge Steel Framing

Fire Rating	Design No.	Page
1-hr	UL L524	24
1 1/2-hr	UL L527	24
1-hr	UL L565	24

Gypsum Board Floor/Ceiling – Steel Framing (steel joists with concrete floor)

Fire Rating	Design No.	Page
1-hr	OSU T-1936	24
1-hr	FM FC-134	25
2-hr	UL G503	24
2-hr	UL G514	25
3-hr	UL G512	25
2-hr	FM FC-134	25
2-hr	UL G523	25
2-hr	UL D502	25
2-hr	UL G222	25
2-hr	FM FC-299	25
1 1/2-hr	UL G259	25
1 1/2-hr	FM FC-300	25

Gypsum Board Roof/Ceiling – Light Gauge Steel Framing (pitched roof truss)

Fire Rating	Design No.	Page
1-hr	UL P540	26
1-hr	UL P541	26
2-hr	UL P543	26

Gypsum Board Roof/Ceiling – Steel Framing (steel joists)

Fire Rating	Design No.	Page
1-hr	FM RC-227	26

Gypsum Board Horizontal Shaftwall Duct Protection

Fire Rating	Design No.	Page
2-hr	WHI 694-0300.1	26

QUICK SELECTOR FOR FIRE AND SOUND RATED SYSTEMS

NOTES FOR USE OF QUICK SELECTOR

The construction systems shown here are representative of the many National Gypsum Drywall partitions and ceilings systems using Gold Bond BRAND products that have been the subject of controlled laboratory testing or engineering evaluations. For a given Fire Resistance Rating or Sound Isolation value, simply scan the appropriate columns. Design references prefixed by "Based on..." are extrapolations from test data on similar assemblies.

In the drawings, in steel or wood stud partitions where insulation is shown in half of the partition cavity, the insulation is required for sound ratings only. Where shown across full cavity, insulation is required for fire rating. Size of studs are minimum and spacing of studs are maximum for fire rating. Steel studs are 25 gauge if not specified.

In the following Quick Selector, Underwriters Laboratories, Inc. Design Numbers refer to designs contained in the *UL Fire Resistance Directory*. National Gypsum Company, Gold Bond BRAND Fire-Shield and Fire-Shield C products bear the UL Classification Mark and are covered by UL's Classification and Follow-Up Service.

In the following listings, 5/8" Fire-Shield C Gypsum Board may be substituted for 5/8" Fire-Shield in all designs listed for 5/8" Fire-Shield. 5/8" Fire-Shield C must be used in designs listed for 5/8" Fire-Shield C.

Descriptions in the Quick Selector tables are summaries. For copies of tests and/or for detailed information, consult your National Gypsum Field Representative (reference inside back cover).

GYPSUM BOARD CORE UL DESIGNATIONS



1/2" (12.7 mm) Fire-Shield C:	FSW-C
1/2" (12.7 mm) XP Fire-Shield C:	FSMR-C
5/8" (15.9 mm) Fire-Shield:	FSW
5/8" (15.9 mm) XP Fire-Shield:	FSW-3
5/8" (15.9 mm) Fire-Shield C:	FSW-C
1/2" (12.7 mm) Fire-Shield C Kal-Kore:	FSK-C
5/8" (15.9 mm) Fire-Shield Kal-Kore:	FSK
5/8" (15.9 mm) Hi-Abuse XP Fire-Shield:	FSW
5/8" (15.9 mm) Hi-Impact XP Fire-Shield:	FSW-5
5/8" (15.9 mm) Fire-Shield Exterior Soffit Board:	FSW
5/8" (15.9 mm) Fire-Shield Jumbo Sheathing:	FSW-3
5/8" (15.9 mm) Fire-Shield e ² XP:	FSW-6
1" (25.4 mm) Fire-Shield Shaftliner:	FSW
1" (25.4 mm) Fire-Shield Shaftliner XP:	FSW

KEY TO ABBREVIATIONS:

- UL – Underwriters Laboratories, Inc.
- OSU – Building Research Laboratories
The Ohio State University
- FM – Factory Mutual Research Corporation
- GA – Gypsum Association
- OC – Owens-Corning Fiberglas Corp.
(Tests by Geiger & Hamme)
- BBN – Bolt Beranek & Newman
- TL – Indicates tests for National Gypsum Company
by Riverbank Acoustical Laboratories
- NGC – National Gypsum Company
- WHI – Warnock-Hersey International, Inc.
- U. of Cal. – University of California
- PFS – PFS Corporation
- NBS – National Bureau of Standards
- BMS – Building Materials and Structures
- ITS – Intertek Testing Services

QUICK SELECTOR FOR FIRE AND SOUND RATED SYSTEMS



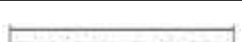

Gypsum Plaster Partitions - Metal Lath (CAD FILE NAME **GOLDA.DWG** OR **GOLDA.DXF**)

No.	Fire Rating	Ref.	Design No.	Description	STC	Test No.
1	1 hr. 	OSU	T-147	1 1/2" (38.1 mm) gypsum plaster, 100:2 1/2 perlite (scratch and brown coats), on metal lath attached to 3/4" (19.0 mm) channel studs at 16" o.c. (406 mm).	None	None
2	1 hr. 	OSU	T-129	2" (51 mm) gypsum plaster, 1:2 sand, on 3.4 diamond mesh lath attached to 3/4" (19.0 mm) channel studs at 16" o.c. (406 mm).	37	NBS 171A
3	2 hr. 	UL	U413	2 1/2" (63.5 mm) gypsum plaster, 100:2 perlite, on 3.4 diamond mesh lath attached to 3/4" (19.0 mm) channel studs at 16" o.c. (406 mm).	33	Est.
4	2 hr. 	NBS		2 1/2" (63.5 mm) gypsum plaster, 100:2 vermiculite scratch coat, 100:3 vermiculite brown coat on metal lath attached to 3/4" (19.0 mm) channel studs at 16" o.c. (406 mm).	None	None



*The fire resistance of the above assemblies was determined with one plane of metal lath. The assemblies with two planes of metal lath may be considered to have equivalent fire-resistant ratings.

QUICK SELECTOR FOR FIRE AND SOUND RATED SYSTEMS

Gypsum Plaster Fireproofing Columns (10WF49 or heavier) (CAD FILE NAME **GOLDB.DWG** OR **GOLDB.DXF**)

No.	Fire Rating		Ref.	Design No.	Description	STC	Test No.
FIRE – SOUND							
1	1 hr.		BMS GA	92-Table 40 CM 1300	3/4" (19.0 mm) gypsum plaster, 1:3 sand scratch, 1:3 sand brown on metal lath.	None	None
2	2 hr.		UL GA	X402 CM 2320	1" (25.4 mm) gypsum plaster, 100:2 perlite scratch, 100:3 perlite brown, on self-furring lath.	None	None
3	3 hr.		UL GA	X402 CM 3310	1 3/8" (34.9 mm) gypsum plaster, 100:2 perlite scratch, 100:3 perlite brown, on self-furring lath.	None	None
4	4 hr.		UL GA	X402 CM 4410	1 3/4" (44.5 mm) gypsum plaster, 100:2 perlite scratch, 100:3 perlite brown, on self-furring lath.	None	None

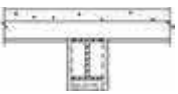
Gypsum Plaster Fireproofing Beams (8WF24 or heavier) (CAD FILE NAME **GOLDC.DWG** OR **GOLDC.DXF**)

1	2 hr.		UL GA	R4197-1 BM 2221	1 1/8" (28.6 mm) gypsum plaster, 100:2 1/2 perlite scratch coat, 100:2 1/2 perlite brown coat on self-furring lath.	None	None
2	3 hr.		UL GA	R4197-1 BM 3110	1 1/4" (38.1 mm) gypsum plaster, 100:2 1/2 perlite scratch coat, 100:2 1/2 perlite brown coat on self-furring lath.	None	None

Veneer Plaster Partitions-Wood Framing (CAD FILE NAME **GOLDD.DWG** OR **GOLDD.DXF**)

No.	Fire Rating		Ref.	Design No.	Description	STC	Test No.
1	1 hr.		U. of Cal.	E.S. 6727	3/32" (2.4 mm) Veneer Plaster applied to 1/2" (12.7 mm) Fire-Shield C Kal-Kore nailed to both sides of wood studs 16" o.c. (406 mm).	34	NGC 2161

Veneer Plaster Partitions-Steel Framing (CAD FILE NAME **GOLDE.DWG** OR **GOLDE.DXF**)

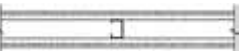
1	1hr.		U. of Cal.	E.S. 6892	3/32" (2.4 mm) Veneer Plaster applied to 1/2" (12.7 mm) Fire-Shield C Kal-Kore on both sides of 2 1/2" (63.5 mm) steel studs 24" o.c. (610 mm) with 1" (25.4 mm) screws 12" o.c. (144 mm) and 9" o.c. (229 mm) along edges. Studs 16" o.c. (406 mm) preferred method.	42 est.	
---	------	---	------------	-----------	---	---------	--



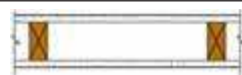
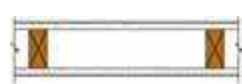

For additional Kal-Kore Fire and Sound rated systems reference gypsum board systems.

Gypsum Board Partitions-Wood Framing (load-bearing) (CAD FILE NAME **GOLDH.DWG** OR **GOLDH.DXF**)

No.	Fire Rating		Ref.	Design No.	Description	STC	Test No.
FIRE – SOUND							
1	45 min.		UL	U317	1/2" (12.7 mm) Fire-Shield C Gypsum Board or 1/2" (12.7 mm) Fire-Shield C Kal-Kore plaster base nailed both sides 2 x 4 (38 mm x 89 mm) studs, 16" o.c. (406 mm).	34	NGC 2161
2	1 hr.		UL GA	U305 WP 3605	5/8" (15.9 mm) Fire-Shield Gypsum Board, 5/8" (15.9 mm) Fire-Shield Kal-Kore plaster base or 5/8" (15.9 mm) Fire-Shield XP Board nailed both sides 2 x 4 (38 mm x 89 mm) wood studs, 16" o.c. (406 mm).	35	NGC 2403

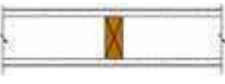
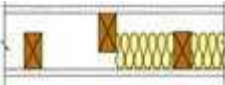
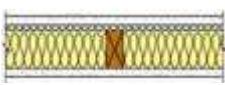
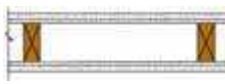
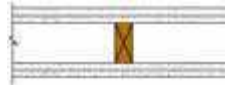
QUICK SELECTOR FOR FIRE AND SOUND RATED SYSTEMS

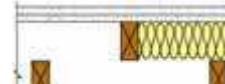
Gypsum Board Partitions-Wood Framing (load-bearing) (cont'd) (CAD FILE NAME **GOLDH.DWG** OR **GOLDH.DXF**)

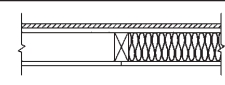
No.	Fire Rating		Ref.	Design No.	Description	STC	Test No.
FIRE – SOUND							
3	1 hr.		UL GA	U309 WP 3510	5/8" (15.9 mm) Fire-Shield Gypsum Board or 5/8" (15.9 mm) Fire-Shield XP Board nailed both sides 2 x 4 (38 mm x 89 mm) studs, 24" o.c. (610 mm).	38	NGC 2404
4	1 hr.		UL	U340	5/8" (15.9 mm) Fire-Shield C Gypsum Board nailed or screwed 7" o.c.(178 mm) to 2x4 (51 mm x 102 mm) wood studs 24" o.c. (610 mm) staggered 12" o.c. (305 mm). Single 6" (152 mm) plate. Sound rating with 3 1/2" (88.9 mm) glass fiber in cavity.	45	Based on NGC 2375
5	1 hr.		WHI GA	694-0200 Based on WP 3230	5/8" (15.9 mm) Fire-Shield C Gypsum Board, screw applied to Resilient Furring Channel spaced 24" o.c. (610 mm) one side only, on 2 x 4 (38 mm x 89 mm) studs spaced 24" o.c. (610 mm). Other side 5/8" (15.9 mm) Fire-Shield C Gypsum Board screw attached direct to studs. 3" (76 mm) mineral wool (3 pcf) in stud cavity.	50	Based on TL 77-138
6	1 hr.		UL FM GA	U312 WP-147 WP 3341	1/2" (12.7 mm) Fire-Shield C Gypsum Board, 1/2" (12.7 mm) Fire-Shield C Kal-Kore plaster base or 1/2" (12.7 mm) Fire-Shield C Durasan laminated to 1/4" Gypsum Board nailed to both sides 2 x 4 (38 mm x 89 mm) studs, spaced 16" o.c. (406 mm).	45	NGC 2321
7	2 hr.		FM GA	WP-360 WP 4135	5/8" (15.9 mm) Fire-Shield Gypsum Board base layer nail applied horizontally to both sides 2 x 4 (38 mm x 89 mm) wood studs, spaced 24" o.c. (610 mm). Face layer 5/8" (15.9 mm) Fire-Shield Gypsum Board nail applied horizontally to both sides. Rating also applies with 5/8" (15.9 mm) Fire-Shield Kal-Kore plaster base.	40	Based on NGC 2363
8	est. 2 hr.		FM GA	Based on WP-360 Based on WP 4135	Two layers 5/8" (15.9 mm) Fire-Shield Gypsum Board nailed one side to 2 x 4 (38 mm x 89 mm) wood studs, 16" o.c. (406 mm). Two layers other side screw applied to Resilient Furring Channels spaced 24" o.c. (610 mm). Rating also applies with 5/8" (15.9 mm) Fire-Shield Kal-Kore plaster base.	50	NGC 2368
9	2 hr.		FM GA	Based on WP-360 WP 3910	Two layers 5/8" (15.9 mm) Fire-Shield Gypsum Board nail applied horizontally to both sides of 2 x 4 (38 mm x 89 mm) wood studs 16" o.c. (406 mm) staggered 8" o.c. (203 mm). Single 6" (152 mm) plate. Rating also applies with 5/8" (15.9 mm) Fire-Shield Kal-Kore plaster base.	51	NGC 2377
10	2 hr.		FM GA	Based on WP-360 WP 3820	5/8" (15.9 mm) Fire-Shield Gypsum Board base layer applied vertically,nailed 24" o.c. (610 mm). Face layer 5/8" (15.9 mm) Fire-Shield Gypsum Board applied horizontally, nailed 8" o.c. (203 mm). Double row of 2 x 4 (38 mm x 89 mm) wood studs 16" o.c. (406 mm) on separate plates, sound rating with 3 1/2" (88.9 mm) mineral wool or glass fiber in cavity. Rating also applies with 5/8" (15.9 mm) Fire-Shield Kal-Kore plaster base.	58	NGC 3056
11	2 hr.		UL	U301	Two layers of 5/8" (15.9 mm) Fire-Shield Gypsum Board or 5/8" (15.9 mm) Fire-Shield Kal-Kore plaster base nail applied to 2 x 4 (38 mm x 89 mm) wood studs spaced 16" o.c (406 mm). Boards may be applied horizontally or vertically with all joints staggered.	40	NGC 2363
EXTERIOR WALLS							
12	2 hr.		UL GA	U302 WP 8410	Two layers 5/8" (15.9 mm) Fire-Shield Gypsum Board nailed horizontally or vertically to inside face of 2 x 4 (38 mm x 89 mm) wood studs 16" o.c. (406 mm). 1/2" (12.7 mm) gypsum sheathing or e ² XP sheathing nailed to outside face of studs, brick veneer facing.		
13	1 hr.		UL GA	Based on U309 WP 8105	5/8" (15.9 mm) Fire-Shield Gypsum Board nailed horizontally or vertically to inside face of 2 x 4 (38 mm x 89 mm) wood studs 24" o.c. (406 mm). 5/8" (15.9 mm) Fire-Shield Gypsum Sheathing e ² XP sheathing nailed vertically to outside face of studs 7" o.c. (178 mm) in field, 4" o.c. (102 mm) perimeter. Exterior cladding attached through sheathing into studs.		

QUICK SELECTOR FOR FIRE AND SOUND RATED SYSTEMS

Gypsum Board Partitions-Wood Framing (load-bearing) (cont'd) (CAD FILE NAME **GOLDH.DWG** OR **GOLDH.DXF**)

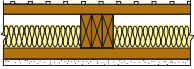
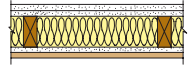

No.	Fire Rating		Ref.	Design No.	Description	STC	Test No.
FIRE – SOUND							
14	1 hr.		WHI	651-0319	5/8" (15.9 mm) Fire-Shield C Gypsum Board horizontally nailed to one side of horizontal 2 x 4 (38 mm x 89 mm) girts spaced 24" o.c. on 6 x 6 wood columns spaced 8'-0" o.c. Metal cladding vertically screw attached to exterior horizontal girts with 3" thick mineral fiber insulation nailed to interior of exterior girts.		
15	2 hr.		UL GA	U371 WP 8417	Two layers 5/8" (15.9 mm) Fire-Shield Gypsum Board screw attached horizontally or vertically to inside face of 2 x 4 (38 mm x 89 mm) wood studs spaced 16" o.c. 5/8" (15.9 mm) Fire-Shield Gypsum Sheathing or e ² XP sheathing nail or screw attached horizontally to outside of studs. Portland Cement Stucco facing. 3" (76 mm) mineral wool in stud cavity.		

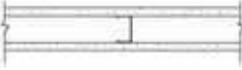
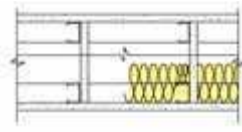
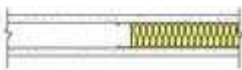
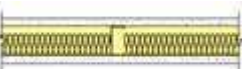
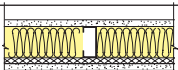
Gypsum Board Partitions-Steel Framing (CAD FILE NAME **GOLDJ.DWG** OR **GOLDJ.DXF**)

No.	Fire Rating		Ref.	Design No.	Description	STC	Test No.
1	1 hr.		OSU GA	T-3296 WP 1340	5/8" (15.9 mm) Fire-Shield Gypsum Board, 5/8" (12.7 mm) Fire-Shield Kal-Kore plaster base, or 5/8" Fire-Shield XP Gypsum Board screw attached vertically to both sides 1/2" (41.3 mm) steel studs, 24" o.c. (610 mm). Gypsum board joints staggered.	38	NGC 2384
2	1 hr.		UL GA	U420 WP 5015	Chase wall, 5/8" (15.9 mm) Fire-Shield Gypsum Board screw attached vertically to both sides. Air space minimum 4 1/2" (114.3 mm) between inside gypsum board faces. Sound rating with 3 1/2" (88.9 mm) mineral wool or glass fiber. 1 5/8" (41.3 mm) steel studs, 24" o.c., (610 mm) cross braced at three points with 5/8" (15.9 mm.) Gypsum board gussets 9 1/2" x 12" (241.3 mm x 305 mm) or 9 1/2" (241.3 mm) long stud track.	52	TL 76-155
3	1 hr.		OSU	Based On T-3296	5/8" (15.9 mm) Fire-Shield Gypsum Board, 5/8" (12.7 mm) Fire-Shield Kal-Kore plaster base or 5/8" (15.9 mm) Fire-Shield XP Gypsum Board screw attached vertically to both sides 2 1/2" (63.5 mm) steel studs, 24" o.c. (610 mm). Gypsum board joints staggered.	40	NGC 2438
			GA	WP 1340	With 2 1/2" (63.5 mm) of mineral wool or glass fiber in cavity.	45	NGC 2391
4	1 hr.		UL UL FM GA	V401 V438 WP-51 WP 1070	1/2" (12.7 mm) Fire-Shield C Gypsum Board or 1/2" (12.7 mm) Fire-Shield C Kal-Kore plaster base screw attached vertically to both sides 2 1/2" (63.5 mm) steel studs, 24" o.c. (610 mm). 2" (51 mm) mineral wool [2.5 pcf (40 kg/m ³)] in stud cavity. Gypsum board joints staggered.	45	NGC 2179
	1 hr.		UL UL FM GA	V401 V438 WP-731 WP 1071	1/2" (12.7 mm) Fire-Shield C Gypsum Board or 1/2" (12.7 mm) Fire-Shield C Kal-Kore plaster base screw attached horizontally to both sides, 2 1/2" (63.5 mm) steel studs, 24" o.c. (610 mm). 2" (51 mm) mineral wool [3 pcf (48 kg/m ³)] in stud cavity. Horizontal joints not staggered with those on the opposite side of partition.		
5	1 hr.		UL	U451	1/2" (12.7 mm) Fire-Shield C Gypsum Board screw applied to resilient furring channel spaced 24" o.c. (610 mm) one side only, on 2 1/2" (63.5 mm) steel studs spaced 24" o.c. (610 mm). Other side 1/2" (12.7 mm) Fire-Shield C Gypsum Board screw attached direct to studs 3" (76 mm) mineral wool (3pcf) in stud cavity.	est. 50	

QUICK SELECTOR FOR FIRE AND SOUND RATED SYSTEMS

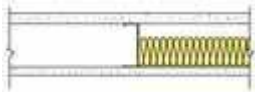
Gypsum Board Partitions-Steel Framing (cont'd) (CAD FILE NAME GOLDJ.DWG OR GOLDJ.DXF)

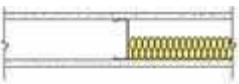
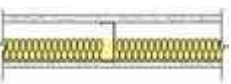
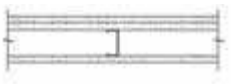
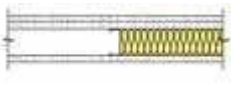
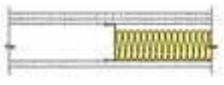
No.	Fire Rating		Ref. Design No.	Description	STC	Test No.	
FIRE – SOUND							
6	1 hr.		FM	WP 45	5/8" (15.9 mm) Fire-Shield Gypsum Board, 5/8" (15.9 mm) Fire-Shield Kal-Kore plaster base or 5/8" (15.9 mm) Fire-Shield XP Gypsum Board screw attached horizontally to both sides 3 5/8" (92.1 mm) steel studs, 24" o.c. (610 mm). All gypsum board joints staggered.	38	NGC 2005004
			GA	WP 1350			
			OSU	T-1770	5/8" (15.9 mm) Fire-Shield Gypsum Board screw attached vertically to both sides 3 5/8" (92.1 mm) steel studs, 24" o.c. (610 mm). Gypsum board joints staggered.		
2386					2 1/2" (63.5 mm) mineral wool or glass fiber in cavity.	47	NGC
			UL	U465	5/8" (15.9 mm) Fire-Shield Gypsum Board, 5/8" (15.9 mm) Fire-Shield Kal-Kore plaster base or 5/8" (15.9 mm) Hi-Impact XP Fire-Shield Gypsum Board screw attached vertically with fasteners 8" o.c. (203 mm) at edges and 12" o.c. (305 mm) in the field of the board to 3 5/8" (92.1 mm) board to 3 5/8" (92.1 mm) steel studs spaced maximum 24" o.c. (610 mm) with joints staggered on opposite sides of the wall.		
			UL	V438			
GA	WP 1081						
7	1 hr.		UL ITS/WHI	V452 J99-4001	1/2" (12.7 mm) PermaBase cement board screw attached horizontally or vertically on one side to 3 5/8" steel studs 16" o.c. (406 mm) and 5/8" (15.9 mm) Fire-Shield Gypsum Board screw attached vertically on opposite side, joints staggered, 3" (76 mm) thick mineral wool batts [2.5 pcf (40 kg/m³)] in stud cavity.	45	NGC 2099015
8	45 min.		FM	Based on WP-51	1/2" (12.7 mm) Fire-Shield C Gypsum Board or 1/2" (12.7 mm) Fire-Shield C Kal-Kore plaster base screw attached vertically to both sides 3 5/8" (92.1 mm) steel studs, 24" o.c. (610 mm). 2" (51 mm) glass fiber in stud cavity. Gypsum board joints staggered.	45	NGC 2146
9	1 hr.		UL FM GA	Based on V401 Based on WP-51 WP 1070	1/2" (12.7 mm) Fire-Shield C Gypsum Board or 1/2" (12.7 mm) Fire-Shield C Kal-Kore plaster base screw attached vertically to both sides 3 5/8" (92.1 mm) steel studs, 24" o.c. (610 mm). 2" (51 mm) mineral wool [2.5 pcf (40 kg/m³)] in stud cavity. Gypsum board joints staggered.	45	NGC 2149
10	1 hr.		FM GA	WP-66 WP 1021	1/2" (12.7 mm) Fire-Shield C Gypsum Board screw vertically applied to 2 1/2" (63.5 mm) steel stud. Double layer on one side, single layer on the other. Base layer screw attached, face layer and single layer screwed at edges, adhesively attached along center. Gypsum board joints staggered.	43	Based on NGC 2248
			FM GA	WP-733 WP 1022	2 1/2" (63.5 mm) screw studs, 24" o.c. (610 mm) double layer of 1/2" (12.7 mm) Fire-Shield Gypsum Board screw applied horizontally one side with face layer staggered 2' (610 mm) from base layer. Other side one layer screw applied horizontally. Face layer horizontal joints each side not staggered.		
11	1 hr.		FM	Based on WP-66	1/2" (12.7 mm) Fire-Shield C Gypsum Board screw attached vertically to both sides 2 1/2" (63.5 mm) steel studs, spaced 24" o.c. (610 mm). Second layer screw attached vertically to one side only and 3" (76 mm) glass fiber in cavity. Gypsum board joints staggered.	50	NGC 2253
			GA	Based on WP 1021			
12	1 hr.		FM	Based on WP-66	1/2" (12.7 mm) Fire-Shield C Gypsum Board screw attached vertically to both sides 3 5/8" (92.1 mm) steel studs, spaced 24" o.c. (610 mm). Second layer screw attached vertically to one side only. Gypsum board joints staggered.	44	NGC 2323
			GA	Based on WP 1021	3" (76 mm) glass fiber cavity.	50	Based on NGC 2253



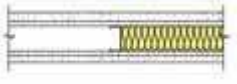
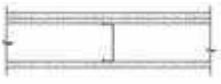
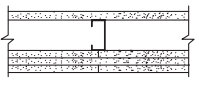
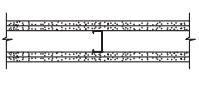
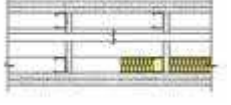
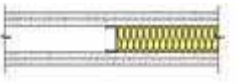
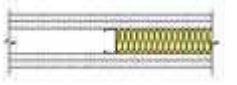
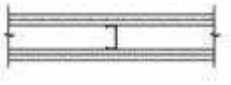
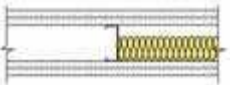

QUICK SELECTOR FOR FIRE AND SOUND RATED SYSTEMS

Gypsum Board Partitions-Steel Framing (cont'd) (CAD FILE NAME [GOLDJ.DWG](#) OR [GOLDJ.DXF](#))

No.	Fire Rating		Ref.	Design No.	Description	STC	Test No.
FIRE – SOUND							
13	1 hr.		UL FM GA	U410 WP-152 WP 1051	1/2" (12.7 mm) Fire-Shield C Gypsum Board, 1/2" (12.7 mm) Fire-Shield C Kal-Kore plaster base or 1/2" (12.7 mm) Fire-Shield Durasan laminated to 1/4" (6.35 mm) Gypsum Board screw attached both sides 2 1/2" (63.5 mm) steel studs, 24" o.c. (610 mm). Gypsum board joints staggered. 2" (51 mm) mineral wool or glass fiber in cavity.	45 53	NGC 2328 NGC 2318
14	1 1/2 hr.		OSU	T-3240	5/8" (15.9 mm) Fire-Shield Gypsum Board or 5/8" (15.9 mm) Fire-Shield XP Board screw attached vertically to both sides 3 5/8" (92.1 mm) steel studs, 24" o.c. (610 mm). Second layer one side only, laminated vertically. Gypsum board joints staggered.	44	NGC 2388
15	2 hr.		UL GA	V449 WP 1943	5/8" (15.9 mm) Fire-Shield Gypsum Board screw attached vertically to both sides 3 1/2" (88.9 mm) steel studs, spaced 24" o.c. (610 mm) Triple layer one side, single layer on the other. Gypsum board joints staggered.		
16	2 hr.		UL	V438	Two layers 1/2" (12.7 mm) Fire-Shield C Gypsum Board screw attached both sides 1 5/8" (41.3 mm) steel studs 24" o.c. (610 mm). Base layers applied vertically, face layers applied vertically or horizontally. Vertical joints staggered.		45 est.
17	2 hr.		UL GA	U420 WP 5105	Chase wall. Two layers 5/8" (15.9 mm) Fire-Shield Gypsum Board screw attached vertically to 1 5/8" (41.3 mm) steel studs, 24" o.c. (610 mm). Air space minimum 4 1/2" (114.3 mm). Sound rating with 3 1/2" (88.9 mm) mineral wool or glass fiber. 1 5/8" (41.3 mm) steel studs, 24" o.c., (610 mm) cross braced at third points with 5/8" (15.9 mm) Gypsum board gussets 9 1/2" x 12" 9 1/2" x 12" (241.3 mm x 305 mm) or 9 1/2" (241.3 mm) long stud track.	57	TL-76-156
18	2 hr.		UL FM GA	U412 WP-635 Based on WP 1615	Two layers 1/2" (12.7 mm) Fire-Shield C Gypsum Board or 1/2" (12.7 mm) XP Fire-Shield Gypsum Board screw attached both sides 2 1/2" (63.5 mm) steel studs, spaced 24" o.c. (610 mm). Base layers vertical, face layers horizontal. All vertical joints staggered.	46	NGC 2250
			U. of Cal. GA	UC9-7-64 Based on WP 1545	3" (76 mm) glass fiber in cavity.	53	NGC 2252
19	2 hr.		UL GA	U411 Based on WP 1711	Base layer 5/8" (15.9 mm) Fire-Shield Gypsum Board screw attached vertically both sides to 2 1/2" (63.5 mm) steel studs 24" o.c. (610 mm). Face layer laminated or screw attached vertically both sides. 2 1/2" (63.5 mm) mineral wool or glass fiber in cavity. Gypsum board joints staggered.	55	NGC 2382
			WHI GA	495-0236 WP 1548	Two layers 5/8" (15.9 mm) Fire-Shield Gypsum Board screw attached horizontally with vertical and horizontal joints staggered and 3" (76 mm) mineral wool or glass fiber in cavity.	56	NGC 3022
20	2 hr.		UL	V438	Two layers 5/8" (15.9 mm) Fire-Shield Gypsum Board or 5/8" (15.9 mm) Hi-Impact XP Fire-Shield Gypsum Board base layer screw attached vertically to both sides 2 1/2" (63.5 mm) steel studs 24" o.c. (610 mm). Vertical joints staggered.		
21	2 hr.		UL FM	U412 Based on WP-635	Two layers 1/2" (12.7 mm) Fire-Shield C Gypsum Board or 1/2" (12.7 mm) XP Fire-Shield Gypsum Board screw attached both sides 3 5/8" (92.1 mm) steel studs, spaced 24" o.c. (610 mm). Base layers vertical, face layers horizontal. All vertical joints staggered.	48	NGC 2282
			GA	Based on WP 1630	3" (76 mm) mineral wool or glass fiber in cavity.	53	NGC 2288

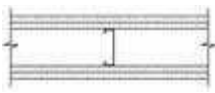
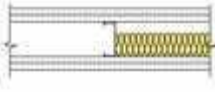

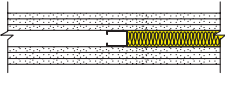
QUICK SELECTOR FOR FIRE AND SOUND RATED SYSTEMS

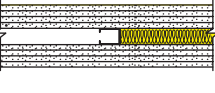
Gypsum Board Partitions-Steel Framing (cont'd) (CAD FILE NAME GOLDJ.DWG OR GOLDJ.DXF)

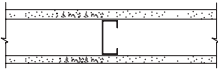

No.	Fire Rating		Ref.	Design No.	Description	STC	Test No.
FIRE – SOUND							
22	2 hr.		OSU GA	T-1771 Based on WP 1711	First layer 5/8" (15.9 mm) Fire-Shield Gypsum Board screw attached vertically both sides 3 5/8" (92.1 mm) steel studs, spaced 24" o.c. (610 mm). Second layer laminated vertically both sides. Vertical joints staggered.	48	NGC 2282
23	2 hr.		UL GA	U411 WP 1616	First layer 5/8" (15.9 mm) Fire-Shield Gypsum Board screw attached vertically both sides 3 5/8" (92.1 mm) steel studs, spaced 24" o.c. (610 mm). Second layer laminated or screw attached vertically both sides and 3" (76 mm) mineral wool or glass fiber in cavity. Vertical joints staggered.	56	NGC 3022
24	2 hr.		UL ITS/WHI	V452 J98-32931	1/2" (12.7 mm) PermaBase cement board face layer screw attached vertically over 1/2" (12.7 mm) Fire-Shield C Gypsum Board base layer on one side to 3 5/8" steel studs 16" o.c. (406 mm) and double layer of 1/2" (12.7 mm) Fire-Shield C Gypsum Board applied vertically to opposite side with 3" (76 mm) thick mineral wool insulation batts [2.5 pcf (40 kg/m³)] in stud cavity. All joints staggered between face and base layers.	52	NGC 2099016
25	3 hr.		UL WHI GA	U435 694-0084 WP 2921	Three layers of 1/2" (12.7 mm) Fire-Shield C Gypsum Board screw attached to each side of 1 5/8" (41.3 mm) steel studs, 24" o.c. (610 mm). Base and second layer vertical, face layer horizontal. All gypsum board joints staggered.	48	NGC 2631
					1 1/2" (38.1 mm) mineral wool or glass fiber in cavity.	53	NGC 2636
26	3 hr.		UL	V438	Three layers of 5/8" (15.9 mm) Fire-Shield Gypsum Board screw attached to each side of 1 5/8" (41.3 mm) steel studs, 24" o.c. (610 mm). Base and second layer vertical, face layer vertical or horizontal. All gypsum board joints staggered.	48	Based on NGC 2631
					1 1/2" (38.1 mm) mineral wool or glass fiber in cavity.	53	Based on NGC 2633
27	4 hr.		UL WHI GA	U435 694-108.1 WP 2970	Four layers of 1/2" (12.7 mm) Fire-Shield C Gypsum Board screw attached to each side of 1 5/8" (41.3 mm) steel studs, 24" o.c. (610 mm). Base, second and third layer vertical, face layer horizontal. All gypsum board joints staggered except long joints of base and second layer fall on the same studs.	51	NGC 2633
					GA WP 2960	1 1/2" (38.1 mm) mineral wool or glass fiber in cavity.	55
28	4 hr.		UL	V438	Four layers of 5/8" (15.9 mm) Fire-Shield Gypsum Board screw attached to each side of 1 5/8" (41.3 mm) steel studs, 24" o.c. (610 mm). Base, second and third layer vertical, face layer vertical or horizontal. All gypsum board joints staggered.	51	Based on NGC 2633
					1 1/2" (38.1 mm) mineral wool or glass fiber in cavity.	55	Based on NGC 2633

QUICK SELECTOR FOR FIRE AND SOUND RATED SYSTEMS

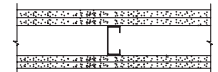
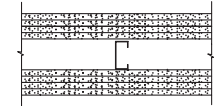
Gypsum Board Partitions-Steel Framing (load-bearing) (CAD FILE NAME **GOLDJ.DWG** OR **GOLDJ.DXF**)

No.	Fire Rating		Ref.	Design No.	Description	STC	Test No.
FIRE – SOUND							
1	1 hr.		UL GA	U425 WP 1206	One layer 5/8" (15.9 mm) Fire-Shield Gypsum Board screw applied vertically to each side of 3 1/2" (88.9 mm) 20 gauge steel studs spaced 24" o.c. (610 mm), studs laterally braced and fastened to tracks. All gypsum board joints staggered on opposite sides.		
2	2 hr.		FM GA	WP-199 WP 1714	Two layers 5/8" (15.9 mm) Fire-Shield Gypsum Board screw applied vertically to each side of 18 gauge 2 1/2" (63.5 mm) steel studs spaced 16" o.c. (406 mm). Base layer joints staggered 16" (406 mm) from joints of base layer. Steel bridging required.	40 est.	
3	2 hr.		UL GA	U425 WP 1716	Two layers 5/8" (15.9 mm) Fire-Shield Gypsum Board screw attached vertically to each side of 3 1/2" (88.9 mm) 20 gauge steel studs spaced 24" o.c. (610 mm), studs laterally braced and fastened to tracks. All gypsum board joints staggered on opposite sides. (Tested at 80 percent of design load.)		
4	3 hr.		UL	U426	Four layers of 1/2" (12.7 mm) Fire-Shield Gypsum Board screw attached to each side of 3 1/2" (88.9 mm) 20 gauge steel studs spaced 24" o.c. (610 mm), studs laterally braced and fastened to tracks. Base, second and third layers applied vertical; face layer may be applied either horizontal or vertical. All gypsum board joints staggered from joints in adjacent layers and on opposite sides of studs.		

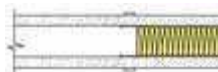
Gypsum Board Partitions/Durasan Prefinished Gypsum Board (CAD FILE NAME **GOLDK.DWG** OR **GOLDK.DXF**)

No.	Fire Rating		Ref.	Design No.	Description	STC	Test No.
1	1 hr.		FM GA	WP-109 WP 6130	30" (762.0 mm) wide 5/8" (15.9 mm) Fire-Shield Durasan applied vertically to 2 1/2" (63.4 mm) steel studs 30" o.c. (762 mm) with steel batten retainers attached to each stud with 1 1/4" (31.8 mm) Type S screws spaced 9" o.c. (229 mm). Attach battens over retainers. 2" (51 mm) glass fiber in cavity.	44	NGC 2218
			UL GA	U405 WP 6040	48" (1219 mm) wide 5/8" (15.9 mm) Fire-Shield Durasan applied vertically to 2 1/2" (63.5 mm) steel studs 24" o.c. (610 mm) with steel batten retainers attached to each stud with 1 1/4" (31.8 mm) Type S screws spaced 9" o.c. (229 mm). Stagger joints on opposite sides 24" o.c. (610 mm). Attach battens over retainers.	41	G&H NG-145FT
2	2 hr.		UL GA	U411 WP 1711	5/8" (15.9 mm) Fire-Shield Durasan laminated vertically with joint compound over base layer 5/8" (15.9 mm) Fire-Shield Gypsum Board attached to 3 5/8" (92.1 mm) steel studs 24" o.c. (610 mm). Face layer laminated with 3/8" (9.5 mm) beads of joint compound 2" o.c. (51 mm). Face layer secured across top and bottom with 1 5/8" (41.3 mm) Type S screws 12" o.c. (305 mm). Joints of outer layer offset 12" (305 mm) from base layer joints. 3" (76 mm) glass fiber or mineral wool in cavity.	56	NGC 3022

Gypsum Board Partitions/Solid (CAD FILE NAME **GOLDL.DWG** OR **GOLDL.DXF**)

No.	Fire Rating	Ref.	Design No.	Description	STC	Test No.
1	1 hr.	FM GA	WP-671 WP 1311	1" (25.4 mm) Fire-Shield Shaftliner with 1/2" (12.7 mm) regular Gypsum Board laminated vertically with Sta-Smooth joint compound, both sides.	34	Based on NGC 2359
2	2 hr.	UL FM GA	U525 WP-668 WP 1841	1" (25.4 mm) Fire-Shield Shaftliner with 1/2" (12.7 mm) Fire-Shield C Gypsum Board laminated vertically with Sta-Smooth joint compound, both sides.	34	Based on NGC 2359
3	2 hr.	UL GA	U505 WP 7210	1" (25.4 mm) Fire-Shield Shaftliner with 5/8" (15.9 mm) Fire-Shield Gypsum Board laminated vertically with Sta-Smooth joint compound, both sides.		
4	2 hr.	UL	U529	1" (25.4 mm) Fire-Shield Shaftliner with 1/2" (12.7 mm) Fire-Shield C Gypsum Board laminated vertically with Sta-Smooth joint compound, both sides.		

QUICK SELECTOR FOR FIRE AND SOUND RATED SYSTEMS

Gypsum Board Partitions-Shaftwalls, Area Separation Walls (CAD FILE NAME **GOLDM.DWG** OR **GOLDM.DXF**)

No.	Fire Rating	Ref.	Design No.	Description	STC	Test No.
FIRE – SOUND						
1	1 hr.	UL FM GA	U499 WP-755 WP 6905	2 1/2" (63.5 mm), 4" (102 mm) or 6" (152 mm) I-Studs, C-T Studs or C-H Studs 24" o.c. (610 mm). 1" (25.4 mm) Fire-Shield Shaftliner or 1" Fire-Shield Shaftliner XP, one layer of 5/8" (15.9 mm) Fire-Shield Gypsum Board applied horizontally or vertically on side opposite shaftliner. Fire tested both sides.	37	NGC 2001003
				1 1/2" (38.1 mm) mineral wool or glass fiber in cavity.	42	NGC 2542
2	2 hr.	UL FM GA GA	U498 WP-545 WP 7079 ASW 1215	2 1/2" (63.5 mm), 4" (102 mm) or 6" (152 mm) I-Studs, C-T Studs or C-H Studs 24" o.c. (610 mm). 1" (25.4 mm) Fire-Shield Shaftliner or 1" Fire-Shield Shaftliner XP, and 1 layer of 1/2" (12.7 mm) Fire-Shield C Gypsum Board, 1/2" (12.7 mm) Fire-Shield C Kal-Kore veneer plaster base, or 1/2" (12.7 mm) Fire-Shield C XP Gypsum Board applied horizontally on each side. Horizontal and vertical joints staggered. Fire tested both sides.	40	NGC 2618
				1 1/2" (38.1 mm) mineral wool or glass fiber in cavity.	45	NGC 2617
		U. of Cal. GA	75-19 ES 7407 WP 7077	5/8" (15.9 mm) Fire-Shield Gypsum Board as face layers.	40	Based on NGC 2618
3	2 hr.	UL GA	U429 WP 7084	2 1/2" (63.5 mm), 4" (102 mm) or 6" (152 mm) C-T Studs or C-H Studs 24" o.c. (610 mm), 1" (25.4 mm), Fire-Shield Shaftliner or 1" Fire-Shield Shaftliner XP and 1 layer of 1/2" (12.7 mm) Fire-Shield C Gypsum Board applied vertically on each side. Joints staggered 24" on opposite sides.	40	Based on NGC 2618 Based on NGC 2617
				1 1/2" (38.1 mm) mineral wool or glass fiber in cavity.	45	
4	2 hr.	UL FM GA	U497 WP-636 WP 7080	2 1/2" (63.5 mm), 4" (102 mm) or 6" (152 mm) I-Studs, C-T Studs or C-H Studs 24" o.c. (610 mm). 1" (25.4 mm) Fire-Shield Shaftliner or 1" Fire-Shield Shaftliner XP and 2 layers of 1/2" (12.7 mm) Fire-Shield C Gypsum Board, 1/2" (12.7 mm) Fire-Shield C Kal-Kore veneer plaster base, or 1/2" (12.7 mm) Fire-Shield C XP Gypsum Board on corridor side only, base layer horizontal, face layer vertical. Fire tested both sides.	40	NGC 2615
				1 1/2" (38.1 mm) mineral wool or glass fiber in cavity.	47	NGC 2616
		UL WHI	U497 651-0500.05	2 1/2" (63.5 mm), 4" (102 mm) or 6" (152 mm) I-Studs, C-T Studs or C-H Studs 24" o.c. (610 mm). 1" (25.4 mm) Fire-Shield Shaftliner or 1" Fire-Shield Shaftliner XP and two layers 1/2" (12.7 mm) Fire-Shield C Gypsum Board applied horizontally on corridor side. Fire tested both sides.	40	Based on NGC 2615
		U. of Cal. GA	75-17 ES 7408 WP 7076	2 layers 5/8" (15.9 mm) Fire-Shield Gypsum Board on corridor side.	40	Based on NGC 2615

QUICK SELECTOR FOR FIRE AND SOUND RATED SYSTEMS

Gypsum Board Partitions-Shaftwalls, Area Separation Walls (CAD FILE NAME **GOLDM.DWG** OR **GOLDM.DXF**)

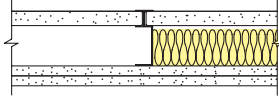
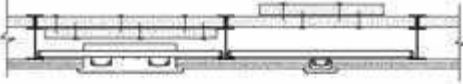
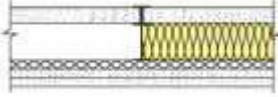
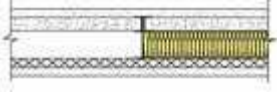
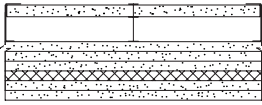
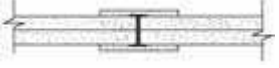
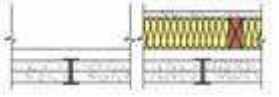
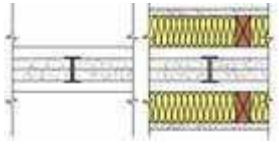
No.	Fire Rating	Ref.	Design No.	Description	STC	Test No.
FIRE – SOUND						
5	2 hr.	UL GA	U428 WP 7051	 <p>2 1/2" (63.5 mm), 4" (102 mm) or 6" (152 mm) C-T Studs or C-H Studs 24" o.c. (610 mm). 1" (25.4 mm) Fire-Shield Shaftliner or 1" Fire-Shield Shaftliner XP and 2 layers of 1/2" (12.7 mm) Fire-Shield C Gypsum Board, base layer horizontal, face layer vertical.</p> <p>1 1/2" (38.1 mm) mineral wool or glass fiber in cavity.</p>	40	Based on NGC 2615
6	2 hr.	FM FM	WP-621 WP-612	 <p>Elevator Control Boxes, 4" (102 mm) or 6" (152 mm) I-Studs 24" o.c. (610 mm). 1" (25.4 mm) Fire-Shield Shaftliner or 1" Fire-Shield Shaftliner XP and two layers 1/2" (12.7 mm) Fire-Shield C Gypsum Board on side only, base layer horizontal, face layer vertical. Control boxes corridor and conduit penetrations.</p>	None	None
7	est. 2 hr.	FM	Based on WP-636	 <p>2 1/2" (63.5 mm), 4" (102 mm) or 6" (152 mm) I-Studs, C-T Studs or C-H Studs 24" o.c. (610 mm). 1" (25.4 mm) Fire-Shield Gypsum Shaftliner, or 1" Fire-Shield Shaftliner XP, Resilient Furring Channels 24" o.c. (610 mm) on corridor side and two layers 1/2" (12.7 mm) Fire-Shield C Gypsum Board on channels, 1 1/2" (38.1 mm) mineral wool or glass fiber in stud cavity.</p>	51	BBN NGC 2609
8	2 hr.	FM	Based on WP-545	 <p>2 1/2" (63.5 mm), 4" (102 mm) or 6" (152 mm) I-Studs, C-T Studs or C-H Studs 24" o.c. (610 mm). 1" (25.4 mm) Fire-Shield Shaftliner or 1" Fire-Shield Shaftliner XP and 1 layer of 1/2" (12.7 mm) Fire-Shield C Gypsum Board or 1/2" (12.7 mm) Fire-Shield C XP Gypsum Board on one side. Other side 1 layer 1/2" (12.7 mm) Fire-Shield C Gypsum Board screwed to Resilient Furring Channels 24" o.c. (610 mm) attached to I-Studs with screws in alternate legs. 1 1/2" (38.1 mm) mineral wool or glass fiber in cavity.</p>	50	BBN NGC 2610
9	4 hr.	UL GA	V451 WP 7691	 <p>4" (102 mm) I-Studs, C-T Studs or C-H Studs 24" o.c. (610 mm) 1" (25.4 mm) Fire-Shield Shaftliner or 1" Fire-Shield Shaftliner XP and five layers of 5/8" (15.9 mm) Fire-Shield C Gypsum Board applied vertically to corridor side. Furring channel applied horizontally 16" o.c. (406 mm) over third layer. Vertical joints staggered.</p>		
10	2 hr.	WHI	694-0200.6	 <p>2 layers of 1" (25.4 mm) Fire-Shield Shaftliner or 1" Fire-Shield Shaftliner XP inserted in 2" H-Stud 24" o.c. (610 mm). H-Studs and Track covered by 1/2" (12.7 mm) Fire-Shield C Gypsum Board 6" (152 mm) wide strips.</p>	35	NGC 2827
11	2 hr.	WHI	651-0508	 <p>2 layers of 1" (25.4 mm) Fire-Shield Shaftliner or 1" Fire-Shield Shaftliner XP inserted in 2" H-Stud 24" o.c. (610 mm). One nominal 2 x 4 (38 mm x 89 mm) wood stud wall one side. 1" (25.4 mm) air space between Shaftliner and wood studs. Wood studs 16" o.c., (406 mm) faced with one layer 1/2" Regular Gypsum Board.</p> <p>3 1/2" (88.9 mm) mineral wool or glass fiber in wood stud cavity.</p>	50	NGC 2826
12	2 hr.	UL GA	U347 ASW 1005	 <p>2 layers of 1" (25.4 mm) Fire-Shield Shaftliner or 1" Fire-Shield Shaftliner XP inserted in 2" H-Stud 24" o.c. (610 mm). Adjacent construction each side. Minimum 3/4" (19.0 mm) air space between Shaftliner and adjacent construction.</p> <p>3 1/2" (88.9 mm) mineral wool or glass fiber in both wood stud cavities.</p> <p>3 1/2" (88.9 mm) mineral wool or glass fiber in wood stud cavity one side.</p>	50	NGC 2823
					61	TL 05-199
					55	NGC 2824

QUICK SELECTOR FOR FIRE AND SOUND RATED SYSTEMS

Gypsum Board Column Fireproofing (CAD FILE NAME GOLDN.DWG OR GOLDN.DXF)

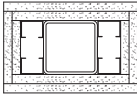
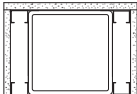
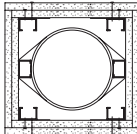
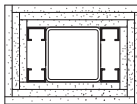
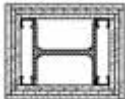
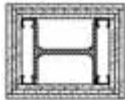
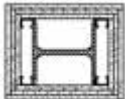
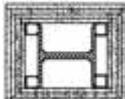
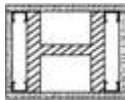
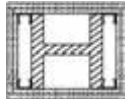
No.	Fire Rating		Ref.	Design No.	Description
LIGHT COLUMN					
1	1 hr.		UL GA	X528 CM 1452	Two layers of 1/2" (12.7 mm) Fire-Shield C Gypsum Board furred from TS 4x4x0.188 tube steel column by 1 5/8" (43.3 mm) steel stud each corner.
2	1 hr.		UL GA	X528 CM 1851	One layer of 5/8" (15.9 mm) Fire-Shield Gypsum Board furred from TS 8x8x0.250 tube steel column by 1 5/8" (43.3 mm) steel stud each corner.
3	1 1/2 hr.		UL	X531	Two layers of 1/2" (12.7 mm) Fire-Shield C Gypsum Board furred from 4 1/2" OD steel pipe column (Min. wall thickness 0.109) by 1 5/8" (43.3 mm) steel framing.
4	2 hr.		UL GA	X528 CM 2452	Base and second layer 1/2" (12.7 mm) Fire-Shield C Gypsum Board furred from TS 4x4x0.188 tube steel column by 1 5/8" (43.3 mm) steel stud each corner. Face layer 5/8" (15.9 mm) Fire-Shield Gypsum Board.
COLUMN (10WF-49)					
5	1 hr.		UL GA	X528 CM 1001	One layer of 1/2" (12.7 mm) Fire-Shield C Gypsum Board furred from column by 1 5/8" (41.3 mm) steel studs at each corner.
6	2 hr.		UL GA	X528 CM 2017	Base layer of 5/8" (15.9 mm) Fire-Shield Gypsum Board furred from column by 1 5/8" (41.3 mm) steel studs at each corner. Face layer 1/2" (12.7 mm) Fire-Shield C Gypsum Board.
7	3 hr.		UL GA	X510 CM 3120	Three layers of 5/8" (15.9 mm) Fire-Shield Gypsum Board furred from column by 1 5/8" (41.3 mm) steel studs at each corner.
8	4 hr.		UL	X501	Four layers of 5/8" (15.9 mm) Fire-Shield C Gypsum Board on each side of column. Inner two layers furred from column by 1 5/8" (41.3 mm) steel studs at column corners. Outer two layers attached to 2" x 2" (51 mm x 51 mm) sheet metal angles which are applied at corners over first two layers of board.
COLUMN (14WF-228)					
9	2 hr.		UL GA	X520 CM 2110	One layer of 1/2" (12.7 mm) Fire-Shield C Gypsum Board furred from column by 1 5/8" (41.3 mm) steel studs at each corner.
10	3 hr.		UL GA	X513 CM 3130	Two layers of 1/2" (12.7 mm) Fire-Shield C Gypsum Board furred from column by 1 5/8" (41.3 mm) steel studs at each corner.

QUICK SELECTOR FOR FIRE AND SOUND RATED SYSTEMS

Gypsum Board Beam Fireproofing (8WF24 or heavier) (CAD FILE NAME **GOLDN.DWG** OR **GOLDN.DXF**)

No.	Fire Rating	Ref.	Design No.	Description
1	2 hr.	UL GA	N501 BM 2120	Two layers of 5/8" (15.9 mm) Fire-Shield Gypsum Board applied to beam cage fabricated from 25 gauge steel channel brackets spaced 24" o.c.

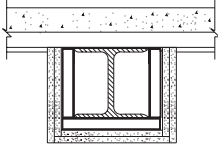



Gypsum Board Floor/Ceilings – Wood Framing (wood joists) (CAD FILE NAME **GOLDS.DWG** OR **GOLDS.DXF**)

No.	Fire Rating	Ref.	Design No.	Description	STC	Test No.	IIC	
							No Carpet	Carpet & Pad
1	1 hr.	UL GA	L522 FC 5410	1/2" (12.7 mm) Fire-Shield C Gypsum Board or 1/2" (12.7 mm) Fire-Shield C Kal-Kore plaster base nail attached to 2 x 10 (38 mm x 241 mm) wood joists spaced 16" o.c. (406 mm). UL design L522 permits option of floor topping over plywood.	37	NGC 4042 NGC 5032A NGC 5033	32	66
	1 hr.	UL GA	L501 FC 5420	5/8" (15.9 mm) Fire-Shield Gypsum Board, 5/8" (15.9 mm) Fire-Shield Kal-Kore plaster base or 5/8" (15.9 mm) F.S. Soffit Board nail attached to 2 x 10 (38 mm x 241 mm) wood joists spaced 16" o.c. (406 mm). UL design L501 permits option of Floor Topping Mixture over plywood.	37	Based on NGC 4024	32	66
2	1 hr.	UL	L515	1/2" (12.7 mm) Fire-Shield C Gypsum Board or 1/2" (12.7 mm) Fire-Shield C Kal-Kore plaster base screw attached to Resilient Furring Channels spaced 24" o.c. (610 mm) on 2 x 10 (38 mm x 241 mm) wood joists 16" o.c. (406 mm). Gypsum Board secured to channels with 1" self-drilling screws 12" o.c. (305 mm). Option in UL L515 allows Drywall Suspension System to be hung from joists. No insulation in plenum.	45	NGC 4010 NGC 4107 NGC 5161 NGC 5165	39	63
		FM	FC 181	With 3 1/2" (88.9 mm) glass fiber.	est. 50			
3	1 hr.	FM	FC 193	1/2" (12.7 mm) Fire-Shield C Gypsum Board attached to Resilient Furring Channels spaced 24" o.c. (610 mm) with screws spaced 12" (305 mm). Elastizell concrete floor 1 1/2" (38.1 mm) thick, 3 1/2" (88.9 mm) mineral wool or glass fiber insulation 2 x 10 (38 mm x 241 mm) wood joists 16" o.c. (406 mm).	58	OC-2MT		
4	1 hr.	FM GA GA GA	FC-172 FC 5406 RC 2601 RC 2602	Base layer 5/8" (15.9 mm) Fire-Shield Gypsum Board attached with screws 24" o.c. (610 mm) to wood joists or trusses 24" o.c. (610 mm). Second layer 5/8" (15.9 mm) Fire-Shield Gypsum Board or 5/8" (15.9 mm) F.S. Soffit Board screw attached 12" o.c. (305 mm). 1/2" (12.7 mm) plywood floor. Ceiling provides one hour fire resistance protection for wood framing, including trusses.				
5	2 hr.	UL GA	L505 FC 5724	5/8" (15.9 mm) Fire-Shield C Gypsum Board, base layer nailed at right angles to 2 x 10 (38 mm x 241 mm) wood joists spaced 16" o.c. (406 mm), resilient furring channels spaced 24" o.c. (610 mm) and nailed through base board into and at right angles to joists. Face layer of 5/8" (15.9 mm) Fire-Shield C Gypsum Board screwed to furring channel. Nominal 1" (25.4 mm) T & G sub and finish floor. Optional floor systems consist of Floor Topping Mixture over plywood. Rating also applies with 5/8" (15.9 mm) Fire-Shield C Kal-Kore plaster base.	est. 45			

QUICK SELECTOR FOR FIRE AND SOUND RATED SYSTEMS

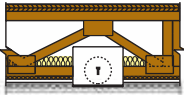
Gypsum Board Floor/Ceilings – Wood Framing (floor truss) (CAD FILE NAME **GOLDS.DWG** OR **GOLDS.DXF**)

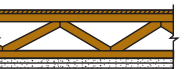
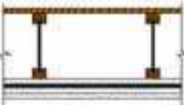
No.	Fire Rating		Ref.	Design No.	Description	STC	Test No.	IIC
6	1 hr.		UL GA	L558 FC 5514	One layer 5/8" (15.9 mm) Fire-Shield C Gypsum Board or 5/8" (15.9 mm) Fire-Shield C Kal-Kore plaster base screw attached to 1/2" (12.7 mm) resilient furring channel spaced 12" o.c. to lower chord of 18" (457.2 mm) deep wood trusses of 2 x 4 (38 mm x 89 mm) lbr. with steel truss plates spaced 24" o.c. (610 mm) 23/32" (18.2 mm) 23/32" (18.2 mm) plywood subfloor with 15/32" (11.9 mm) plywood finish floor. Optional - 3 1/2" thick glass fiber insulation draped over furring channels - Optional Ceiling damper.			
7	1 hr.		FM GA	FC-442 FC 5517	One layer 5/8" (15.9 mm) Fire-Shield C Gypsum Board applied perpendicular and screw attached directly to the lower chord of 14" (35.6 mm) deep wood-webbed trusses of 2 x 4 (38 mm x 89 mm) lbr. with Type I.L.S. plates spaced 24" o.c. (610 mm). Edge joints backed with 2 x 4 (38 mm x 89 mm) wood blocks fastened to lower chord with Z-clips. 19/32" (15.1 mm) plywood floor sheathing.			
8	1 hr.		UL FM GA	L528 FC-448 FC 5516	One layer 5/8" (15.9 mm) Fire-Shield C Gypsum Board screw attached to 7/8" (22.2 mm) furring channel wire tied perpendicular to lower chord of wood-webbed trusses of 2 x 4 (38 mm x 89 mm) lbr. with steel truss plates spaced 24" o.c. (610 mm). Floor 3/4" (19.1 mm) nominal plywood. Optional resilient furring channels.			
9	1 hr.		FM GA	FC 214 FC 5512	Two layers 1/2" (12.7 mm) Fire-Shield C Gypsum Board each screwed perpendicular, with all joints of face layer staggered 24" o.c. (610 mm) from base layers, to 24" o.c. (610 mm) trusses fabricated using connectors produced by members of the Truss Plate Institute. 5/8" (15.9 mm) T & G (long sides) plywood flooring nail applied across top chord of trusses.	est. 43		
10	2 hr.		UL	L538	5/8" (15.9 mm) Fire-Shield C Gypsum Board, base layer screw attached perpendicular to bottom chord of 9 1/2" (241.3 mm) deep "I" shaped wood spaced 19.2" (487.8 mm) o.c. Resilient furring channel or 7/8" (22.2 mm) deep furring channel spaced 16" o.c. screw attached through base layer into and at right angles to joist. 5/8" (15.9 mm) Fire-Shield C Gypsum Board, middle and face layers screw attached perpendicular to resilient furring channel or 7/8" (22.2 mm) deep furring channel. 5/8" (15.9 mm) T & G plywood floor sheathing. Rating also applies with 5/8" (15.9 mm) Fire-Shield C Kal-Kore plaster base.			

QUICK SELECTOR FOR FIRE AND SOUND RATED SYSTEMS

Gypsum Board Roof/Ceilings – Wood Framing (Pitched Roof Truss)

11 1 hr.

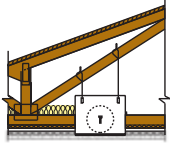

UL
GA

P533
RC 2603

Roof/ceiling, One layer 5/8" (15.9 mm) Fire-Shield C Gypsum Board attached to 1/2" (12.7 mm) resilient furring channel spaced 12" o.c. screw fastened perpendicular to lower chord of wood trusses of 2 x 4 (38 mm x 89 mm) lbr. with steel truss plates, spaced 24" o.c. (610 mm). Roofing system UL Class A, B or C.

Optional - 3 1/2" thick glass fiber insulation draped over furring channels - Optional Ceiling damper.

QUICK SELECTOR FOR FIRE AND SOUND RATED SYSTEMS

Gypsum Board Floor/Ceilings – Light Gauge Steel Framing

No.	Fire Rating	Ref.	Design No.	Description
1	1 hr.	UL GA	L524 FC 4502	Two layers 1/2" (12.7 mm) Fire-Shield C Gypsum Board screw attached perpendicular, face layer joints staggered from base layer joints, to 7" (178 mm) deep, 18 gauge steel "C" shaped joists spaced 24" o.c. (610 mm). 5/8" (15.9 mm) T & G plywood floor sheathing.

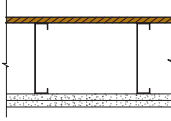

2 1 1/2 hr.

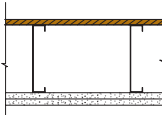

UL

L527

Two layers 5/8" (15.9 mm) Fire-Shield C Gypsum Board screw attached perpendicular, face layer joints staggered from base layer joints, to resilient furring channels spaced 16" (406 mm) o.c. on 9 3/8" deep, 16 gauge steel "C" shaped joists spaced 24" o.c. (610 mm). 3/4" (19.0 mm) T & G plywood floor sheathing.

QUICK SELECTOR FOR FIRE AND SOUND RATED SYSTEMS

Gypsum Board Floor/Ceilings – Light Gauge Steel Framing (floor truss) (CAD FILE NAME [GOLDS.DWG](#) OR [GOLDS.DXF](#))

1 1 hr.

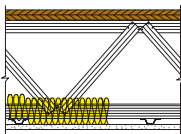

UL
GA

L565
FC 4515

One layer 5/8" (15.9 mm) Fire-Shield C Gypsum Board attached to 1/2" (12.7 mm) resilient furring channels screw fastened perpendicular to lower chord of light gauge steel trusses spaced a maximum 48" o.c. 23/32" (18.2 mm) plywood plywood subfloor with 15/32" (11.9 mm) plywood finish floor.

Optional, mineral wool or glass fiber insulation draped over furring channels.

Gypsum Board Floor/Ceilings – Steel Framing (steel joists with concrete floor) (CAD FILE NAME [GOLDP.DWG](#) OR [GOLDP.DXF](#) OR [GOLDR.DWG](#) OR [GOLDR.DXF](#))

No.	Fire Rating	Ref.	Design No.	Description	STC	Test No.	IIC	
							No Carpet	Carpet & Pad
1	1 hr.	OSU	T-1936	5/8" (15.9 mm) Fire-Shield Gypsum Board screw attached to furring channels spaced 24" o.c. (610 mm) attached to steel bar joists spaced 24" o.c. (610 mm). Concrete floor 2" (51 mm) thick.	53	Based on NGC 4075	21 Based on NGC 5121	67 Based on NGC 5122
	2 hr.	UL	G503	5/8" (15.9 mm) Fire-Shield Gypsum Board or 5/8" (15.9 mm) Fire-Shield Kal-Kore plaster base screw attached to furring channels spaced 12" o.c. (305 mm) attached to or suspended from steel bar joists spaced 24" o.c. (610 mm). Concrete floor 2 1/2" (63.5 mm) thick.	53	(Direct) Based on NGC 4075	21 Based on NGC 5121	67 Based on NGC 5122
					57	(Susp.) Based on NGC 4078	28 Based on NGC 5126	75 Based on NGC 5127

Gypsum Board Floor/Ceilings – Steel Framing (steel joists with concrete floor) (CAD FILE NAME **GOLDP.DWG** OR **GOLDP.DXF** OR **GOLDR.DWG** OR **GOLDR.DXF**)

No.	Fire Rating	Ref.	Design No.	Description	STC	Test No.		IIC	
								No Carpet	Carpet & Pad
2	2 hr.	UL GA	G514 FC 2030	1/2" (12.7 mm) Fire-Shield C Gypsum Board or 1/2" (12.7 mm) Fire-Shield C Kal-Kore plaster base screw attached to furring channels spaced 24" o.c. (610 mm) attached or suspended from steel bar joists spaced 24" o.c. (610 mm) with wire ties spaced 48" (1219 mm). Concrete floor 2 1/2" (63.5 mm) thick.	53	(Direct)	21	67	
	NGC 4075					NGC 5121	NGC 5122		
	3 hr.	UL GA	G512 FC 3012	5/8" (15.9 mm) Fire-Shield C Gypsum Board screw attached to furring channels spaced 24" o.c. (610 mm) attached to steel bar joists spaced 24" o.c. (610 mm) with wire ties. Concrete floor 2 1/2" (63.5 mm) thick.	53	(Susp.)	28	75	
						Based on NGC 4078	Based on NGC 5126	Based on NGC 5127	
3	1 hr.	FM GA	FC-134 FC 1105	1/2" (12.7 mm) Fire-Shield C Gypsum Board applied across 3 5/8" (92.1 mm) steel studs 24" o.c. (610 mm) with drywall screws 12" o.c. (305 mm). Studs wire-tied 8" o.c. (2440 mm) to steel bar joists spaced 24" o.c. (610 mm). 3/8" (9.5 mm) rib metal lath supporting 2 1/2" (63.5 mm) thick concrete slab.	52	Based on NGC 4075	21	67	
4	2 hr.	UL	G523	Single layer 1/2" (12.7 mm) Fire-Shield C Gypsum Board or 1/2" (12.7 mm) Fire-Shield C Kal-Kore plaster base screw applied perpendicular to cross tees of a drywall suspension system that is suspended from steel bar joists 24" o.c. (610 mm), 2 1/2" (63.5 mm) concrete floor over 3/8" (9.5 mm) rib lath.	est. 50				
5	2 hr.	UL	D502	Single layer of 5/8" (15.9 mm) Fire-Shield C Gypsum Board screw applied perpendicular to the cross tees of a drywall suspension system suspended from a steel deck. Concrete floor 2 1/2" (63.5 mm) thick.	est. 50				
6	2 hr.	UL FM GA	G222 FC-299 FC- 2190	Nominal 2' x 2' (610 mm x 610 mm) x 1/2" (12.7 mm) Fire-Shield G Gypsum Boards laid in fire-rated metal grid suspension system supported by hanger wire from steel joists supporting 2 1/2" (63.5 mm) concrete.					
	1 1/2 hr.	UL FM GA	G259 FC-300 FC-1290	Nominal 2' x 4' (610 mm x 1219 mm) x 1/2" (12.7 mm) Fire-Shield G Gypsum Boards laid in fire-rated metal grid suspension system supported by hanger wire from steel joists supporting 2 1/2" (63.5 mm) concrete.					

QUICK SELECTOR FOR FIRE AND SOUND RATED SYSTEMS

Gypsum Board Roof/Ceilings – Light Gauge Steel Framing (pitched roof truss) (CAD FILE NAME [GOLDP.DWG](#) OR [GOLDP.DXF](#) OR [GOLDR.DWG](#) OR [GOLDR.DXF](#))

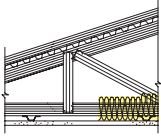
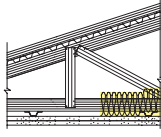
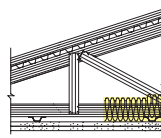
No.	Fire Rating	Ref.	Design No.	Description	STC	Test No.	IIC
1	1 hr.	UL GA	P540 RC-2501	 <p>One layer 5/8" (15.9 mm) Fire-Shield C Gypsum Board attached to 1/2" (12.7 mm) resilient furring channels screw fastened perpendicular to lower chord of light gauge steel trusses spaced a maximum 48" o.c. Roofing system UL Class A, B or C.</p> <p>Optional, mineral wool or glass fiber insulation draped over furring channels.</p>			
2	1 hr.	UL	P541	 <p>Two layers 5/8" (15.9 mm) Fire-Shield Gypsum Board attached to 1/2" (12.7 mm) resilient furring channels screw fastened perpendicular to lower chord of light gauge steel trusses spaced a maximum 48" o.c. Roofing system UL Class A, B or C.</p> <p>Optional, mineral wool or glass fiber insulation draped over furring channels.</p>			
3	2 hr.	UL GA	P543 RC 2752	 <p>Two layers 5/8" (15.9 mm) Fire-Shield C Gypsum Board attached to 1/2" (12.7 mm) resilient furring channels screw fastened perpendicular to lower chord of light gauge steel trusses spaced a maximum 48" o.c. Roofing system UL Class A, B or C.</p> <p>Optional, mineral wool or glass fiber insulation draped over furring channels.</p>			

Gypsum Board Roof/Ceilings – Steel Framing (steel joists) (CAD FILE NAME [GOLDP.DWG](#) OR [GOLDP.DXF](#))

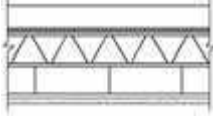
1	1 hr.	FM	RC-227	 <p>(12.7 mm) Fire-Shield C Gypsum Board secured to 22 gauge steel deck with Lexsuco clips and washers 24" o.c. (610 mm). Deck supported by 10" (254 mm) bar joists 68" o.c. (1727 mm). IRMA roof system with 1" (25.4 mm) to 4" (102 mm) Styrofoam and 3 plies of 15 lb. (6.8 kg) felt. Ceiling 1/2" (12.7 mm) Fire-Shield C Gypsum Board on screw furring channels 24" o.c. (610 mm).</p>	est. 53		
---	-------	----	--------	--	---------	--	--

Gypsum Board Horizontal Shaftwall Duct Protection (CAD FILE NAME [GOLDT.DWG](#) OR [GOLDT.DXF](#))

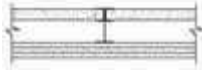
No.	Fire Rating	Ref.	Design No.	Description
1	2 hr.	WHI	694-0300.1	 <p>2 1/2" (63.5 mm), 4" (102 mm) or 6" (152 mm), I-Studs 24" o.c. (610 mm). 1" (25.4 mm) Fire-Shield Shaftliner. 3 layers 1/2" (12.7 mm) Fire-Shield C Gypsum Board. Base and middle layers parallel to studs. Face layer perpendicular.</p>



For additional information
Phone **1-800-NATIONAL**
(1-800-628-4662)

Gold Bond[®] BRAND **Gypsum Sheathing & e²XP[™]** **Extended Exposure Sheathing**

06 16 43



National 
Gypsum[®]

GOLD BOND® BRAND GYPSUM SHEATHING

DESCRIPTION

Gold Bond Brand Gypsum Sheathing is a water resistant board product designed for attachment to the outside of exterior wall framing as a water resistant underlayment for various exterior siding materials. The sheathing is manufactured with a treated water resistant core faced with water repellent paper on both face and back surfaces and on both long edges. Fire-Shield (type X) Jumbo Sheathing has special additives in the core to enhance its fire resistive properties.

USES

1. As a sheathing for wood framed residential construction to provide fire resistance, weather protection and to add to structural strength when used under exterior finishes such as vinyl siding, clapboard, paneling, masonry veneer, stucco and shingles.
2. As a sheathing for steel stud commercial construction

and as a component in curtainwall systems and exterior insulation systems and finishes.

3. As a sheathing for use in fire-rated exterior wall assemblies.

ADVANTAGES

1. **Economical:** Both material and application costs are low.
2. **Fire Resistance:** The non-combustible gypsum core of the sheathing helps protect framing elements even when the siding or finish material is combustible.
3. **Weather Protection:** Gypsum Sheathing's moisture resistant core and water repellent surfaces provide a barrier that resists passage of wind and water.**
4. **Little or No Sawing:** Gypsum Sheathing can be scored and snapped to exact size without cutting or sawing.

TECHNICAL DATA

SIZES AND TYPES

- 1/2" x 4' x 8', 9', 10' (Jumbo) square edge.
- 5/8" x 4' x 8', 9', 10' (Fire-Shield Jumbo) square edge.

VAPOR PERMEABLE

Gypsum Sheathing typically has an average vapor permeance of 20 perms (dry cup method) which allows the escape of normal interior created water vapor.

SURFACE BURNING CHARACTERISTICS: (FIRE HAZARD CLASSIFICATION)

Gypsum Sheathing has a flame spread of 20 when tested under ASTM E 84. Source: Factory Mutual Report No. 16738.102.

FIRE-RESISTANCE RATINGS

A one-hour fire rating can be achieved for a wood framed wall when constructed per UL Design U305 consisting of nominal 2 x 4 wood studs 16" o.c. faced on the outside with 5/8" Fire-Shield Gypsum Sheathing and on the inside with 5/8" Fire-Shield Gypsum Board.

A two-hour fire rating may be obtained per UL Design U371 with 2 x 4 wood studs 16" o.c. with two layers of 5/8" Fire-Shield Gypsum Board applied to the interior side and 5/8" Fire-Shield Gypsum Sheathing, faced with brick veneer on the exterior side.

One and two hour fire ratings may be obtained for a steel framed wall when constructed per UL Designs U 418 and U 425.

STRUCTURAL

Racking tests have been conducted for the Gypsum Association by an independent laboratory according to ASTM E 72. Average ultimate racking load values were as follows:

SHEAR LOAD IN LBS. PER LINEAR FT. (KILOGRAMS PER METER)

	Dry	Wet*
1/2" x 4' (12.7 mm x 1219 mm) wide sheathing	540 (803)	332 (494)
5/8" x 4' (15.9 mm x 1219 mm) wide type X	654 (973)	522 (777)

*Treated core only

Studs spaced 16" o.c., fasteners galvanized 11 gauge nails 7/16" head, 1 1/2" long for 1/2" sheathing and 1 3/4" long for 5/8", 7" o.c. in the field and 4" o.c. on edges and ends for 5/8" Gypsum Sheathing; 8" o.c. in field and 4" o.c. on edges and ends for 1/2" Gypsum Sheathing.

Corner Bracing – Where continuous diagonal bracing is required, many building codes allow the use of 4' wide boards of 1/2" Gypsum Sheathing applied vertically to be used in place of 1" by 4" wood let-in bracing.

Shear Walls – Where wind or seismic forces require shear walls to resist these lateral forces, most building codes provide allowable shear values for walls having gypsum sheathing applied vertically to wood framing. Specific values with construction requirements and limitations are contained in the major model building codes (International Building Code, National Building Code, Standard Building Code and Uniform Building Code).

Shear values for all gypsum board, including Gypsum Sheathing, are defined in GA-229 at www.gypsum.org/GA-229-08.pdf.

SPECIFICATION COMPLIANCE

Gold Bond Gypsum Sheathing is manufactured to comply with ASTM Specification C 1396.

SQUARE EDGES FOR VERTICAL APPLICATION

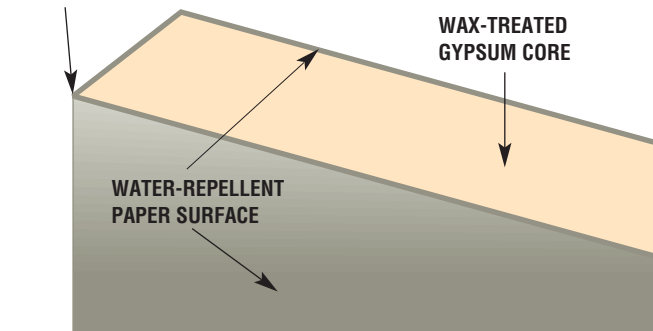

JUMBO GYPSUM SHEATHING

Illustration colors for visualization purposes only.

** Refer to Limitations, page 29, number 10.

LIMITATIONS

1. Gypsum Sheathing is not a finished surface nor is it a substrate for the direct application of stucco, paint or textures. Placement of vapor retarders is the responsibility of the design professional.
2. The sheathing shall not be used as a nailing base.
3. Exterior Insulation Finish Systems (EIFS): Exterior Insulation Finish Systems incorporating Gypsum Sheathing should be used with mechanical fasteners. The performance of these systems and recommendation of the proper method of attachment are the sole responsibility of the EIFS manufacturer.
4. Application of Gypsum Sheathing to framing by adhesive only is not recommended.
5. Stud spacing must not exceed 24" o.c.
6. Gypsum Sheathing is not recommended for application to exterior ceilings, soffits or sills.
7. Gypsum Sheathing should be spaced not less than 1/4" from abutting masonry to minimize wicking.
8. Neatly stack Gypsum Sheathing flat, taking care to prevent sagging or damage to the ends, edges and surfaces.
9. Gypsum Sheathing may be stored outside for up to one month if stacked off the ground under protective covering.
10. Gypsum Sheathing is designed for use as a substrate that is covered by an exterior cladding or other weather resistive barrier and is not intended for long term exposure. After it has been installed, it shall not be exposed to the elements for more than 30 days. The gypsum sheathing shall be covered with building felt or equivalent within 30 days after installation if exposure time will be more than 30 days.
11. Gypsum Sheathing applied perpendicular to framing shall be covered with building felt or equivalent or the horizontal joints shall be sealed at time of application.

DETAILS

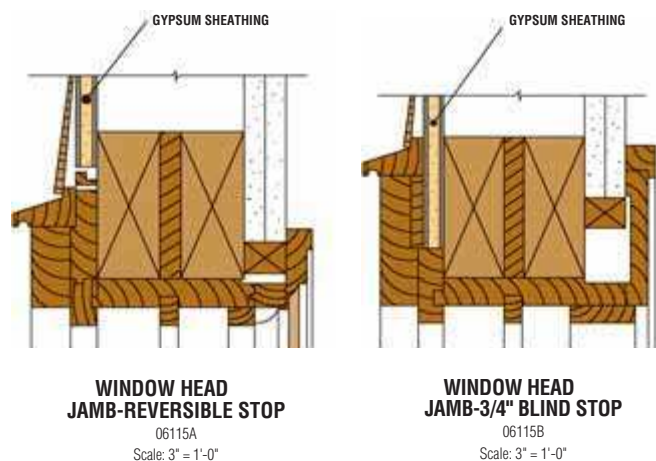

SPECIFICATIONS

SECTION 06 16 43 GYPSUM SHEATHING

THE FOLLOWING PARAGRAPHS ARE FOR INSERTION INTO SECTIONS OF GENERIC SPECIFICATIONS OR GENERIC/PROPRIETARY SPECIFICATIONS COVERING GYPSUM BOARD PRODUCTS. THE GOLD BOND PRODUCT NAME FOLLOWS THE GENERIC DESCRIPTION IN PARENTHESES.

PART 2 PRODUCTS

2.01 MATERIALS

- A. Gypsum Sheathing Board: A gypsum core sheathing boards with additives to enhance the water resistance of the core; surfaced with water repellent paper on front, back, and long edges; and complying with ASTM C 1396.
1. **Regular Board**, 1/2" x 4' x 8', 9', 10' with square edge (Gold Bond BRAND Jumbo Gypsum Sheathing).
 2. **Fire-Resistant Board** (type X), 5/8" x 4' x 8', 9', 10' with additives in the core to enhance fire resistance (Gold Bond BRAND Fire-Shield Jumbo Gypsum Sheathing).

PART 3 EXECUTION

3.01 INSTALLATION

- A. Gypsum Sheathing: In accordance with ASTM C 1280 and the manufacturer's recommendations, National Gypsum Company "Gypsum Construction Guide."

RECOMMENDATIONS

Fasteners (nail or screw heads or the crown of staples) shall bear tightly against the face of the sheathing but should not cut into the face paper. Staples shall be driven with the crown parallel to the framing. Fasteners shall be no less than 3/8" from the edges and ends of the sheathing. When shear values are not required, fasteners shall be spaced not more than 8" o.c. along the vertical ends or edges and intermediate supports.

JUMBO GYPSUM SHEATHING – 4' WIDE

Apply Jumbo Gypsum Sheathing vertically with vertical edges butting over the center of framing members. Fit sheathing snugly around all openings. Vertically attach sheathing with nails or screws spaced not over 4" o.c. around perimeter and 8" o.c. to intermediate studs (space staples not over 3" and 6" o.c. respectively). Jumbo Gypsum Sheathing is permitted to be applied horizontally. Secure horizontally applied sheathing to studs with nails or screws spaced not over 4" o.c. along ends and 8" o.c. to intermediate framing. Square edge gypsum sheathing applied perpendicular to framing shall be covered with building felt or equivalent or horizontal joints shall be sealed at time of application. Horizontal gypsum sheathing joints do not require back blocking.

TOTAL WALL THICKNESS

Door and window frames for outside wall openings should be ordered according to total wall thickness. For ease of installation it is recommended that window frames be selected with blind stops the same thickness as the sheathing.

REVERSIBLE STOPS

Window frames with reversible stops can accommodate 1/2" sheathing. Detail 06115 A.

3/4" BLIND STOPS

For use of fixed 3/4" blind stops with 1/2" sheathing, insert 1/4" shim between sheathing and trim. Detail 06115 B.

INSTALLATION

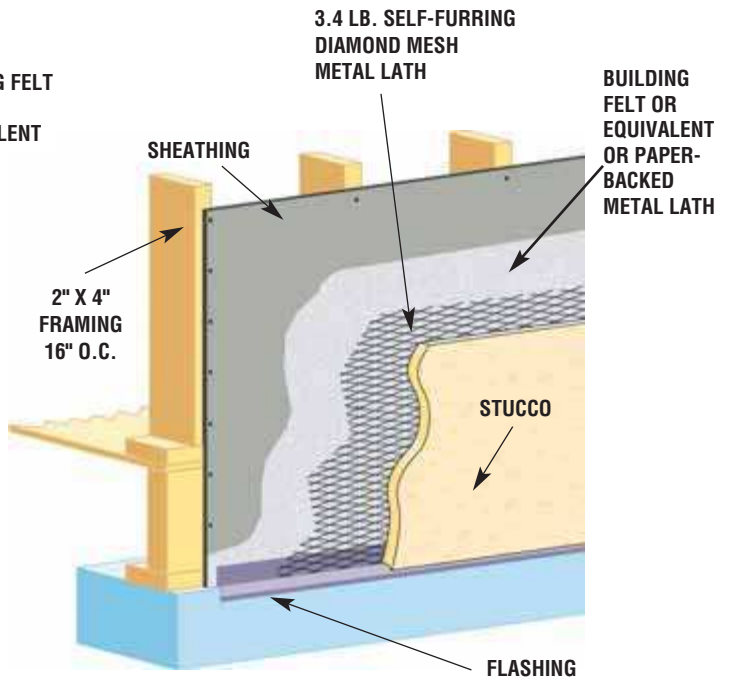
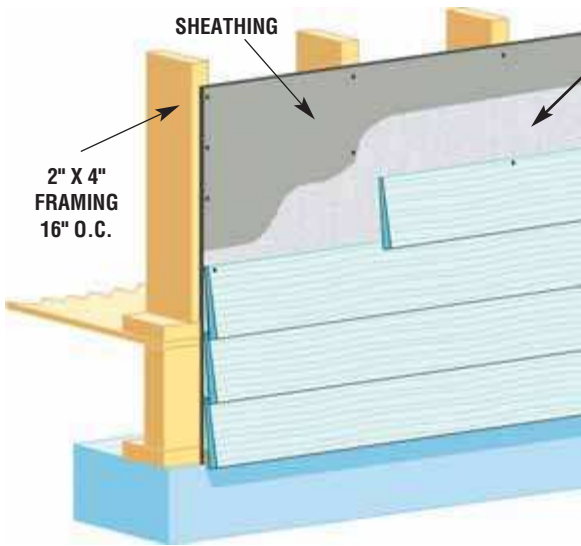

VINYL, WOOD, CLAPBOARD SIDING

Apply horizontal siding directly over the sheathing. Fasteners should have a 1" penetration into each framing member. Butt siding joints over framing members.

STUCCO

Nail 3.4 lb. Self-furring Galvanized Diamond Mesh metal lath through the sheathing into the framing.

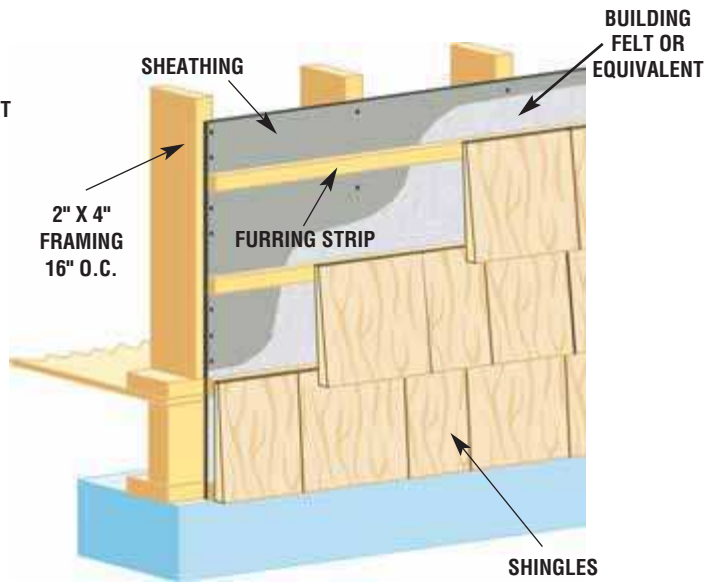
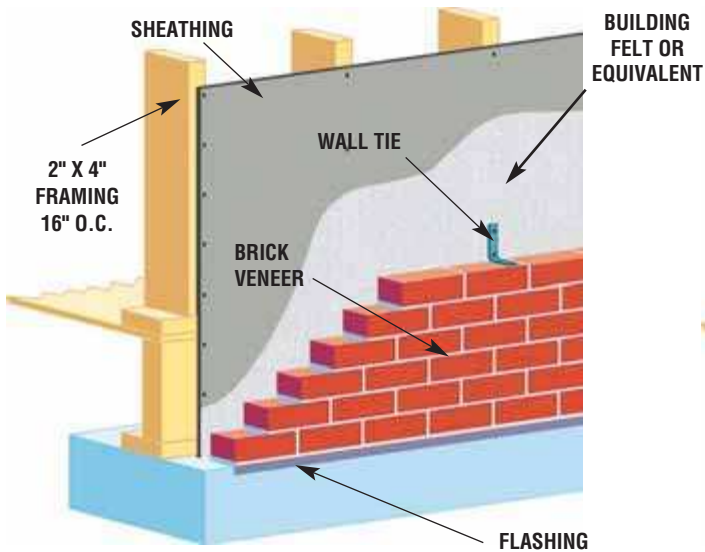

BRICK VENEER

Wall ties for masonry veneer should be nailed through the sheathing with nails that penetrate a minimum of 1" into the framing. Leave an air space of 2" between sheathing and veneer.*

SHINGLES OR SHAKES

Apply 1 x 2 wood furring strips horizontally over the Gypsum Sheathing, spaced to correspond to the shingle exposure, using nails of sufficient length to provide at least 1" penetration into the studs. Nail furring through the sheathing into the framing with a minimum of one nail at each intersection of stud and furring.

*Brick Institute of America

Note: Refer to exterior cladding manufacturer and local codes to determine if a weather resistive barrier is required over gypsum sheathing.

e²XP™ EXTENDED EXPOSURE SHEATHING

DESCRIPTION

e²XP Sheathing is a moisture and mold resistant sheathing panel designed for attachment to the outside of sidewall and soffit framing as a water resistant underlayment for various exterior materials. e²XP Sheathing is manufactured with an enhanced moisture and mold resistant core and facer. The facer is composed of a coated fiberglass mat which provides superior weather resistance capabilities. It is produced in 1/2" and 5/8" thicknesses, 4' wide in 8', 9' and 10' lengths. e²XP Sheathing is lightweight, scores and cuts easily and is specially coated on the front, back and sides for easy handling.

BASIC USES

e²XP Sheathing can be used in both wood and metal stud construction to provide fire resistance, weather protection and to add to structural strength. e²XP Sheathing can be used as a substrate for various air and water resistive barriers including building wraps, self-adhesive membranes and liquid applied coatings. It can be used as a component in curtainwall or Exterior Insulated Finish Systems (EIFS), and under various exterior finishes such as metal, vinyl, wood or fiber-cement siding; brick/stone veneer, or conventional stucco. The 5/8" e²XP Fire-Shield® Type X gypsum panel can be utilized for exterior fire-rated wall and soffit assemblies.

ADVANTAGES

- Manufactured to meet ASTM C 1177 (*Standard Specification for Glass Mat Gypsum Substrate for Use as Sheathing*).
- Will withstand up to 12 months of exposure to typical weather conditions, subject to terms, conditions and exclusions of National Gypsum's Limited Warranties.
- Treated fiberglass face, back and gypsum core provides extra protection against mold growth per ASTM D3273.
- Superior water resistance which does not impede vapor transmission.
- Dimensionally stable under changes in temperature and relative humidity and resists warping, rippling, buckling and sagging for a flat and even substrate.
- Noncombustible material.
- Approved for inclusion in specific UL fire-rated designs.
- Can be scored and snapped to exact size without cutting or sawing.
- Coated face and back for easy handling.
- Ideally suited for soffit applications.
- Suitable for radius applications.

MOLD AND MILDEW RESISTANCE

e²XP Sheathing was designed to provide extra protection against mold and mildew compared to standard gypsum board products. When tested by an independent lab per ASTM D 3273 (*Standard Test Method for Resistance to Growth of Mold on the Surface of Interior Coatings in an Environmental Chamber*), e²XP Sheathing achieved a score of 10, the best possible score for this test. No material can be considered "mold proof," nor is it certain that any material will resist mold or mildew indefinitely. When used in conjunction with good design, handling and construction practices, e²XP Sheathing can provide increased mold resistance versus standard gypsum board products. As with any building material, avoiding water exposure during handling, storage and installation, and after installation is complete, is the best way to avoid the formation of mold or mildew.

LIMITATIONS

- e²XP Sheathing is not a finished surface nor is it a substrate for the direct application of joint

compound, stucco, paint or textures in wall applications.

- All materials in conjunction with e²XP Sheathing should be installed per the manufacturer's recommendations.
- e²XP Sheathing should never be used as a nailing base. Mechanical fasteners should pass through the sheathing and engage the framing member behind the panel.
- e²XP Sheathing is resistant to weather, but it is not intended for immersion in water and should not be subjected to cascading water conditions.
- Do not apply e²XP Sheathing below grade. Always follow building code grade clearance requirements.
- e²XP Sheathing should be protected from the elements and maintained in reasonable condition prior to installation. Boards should be stacked flat with care taken to prevent sagging or damage to edges, ends or surfaces. Following installation, the structure must be

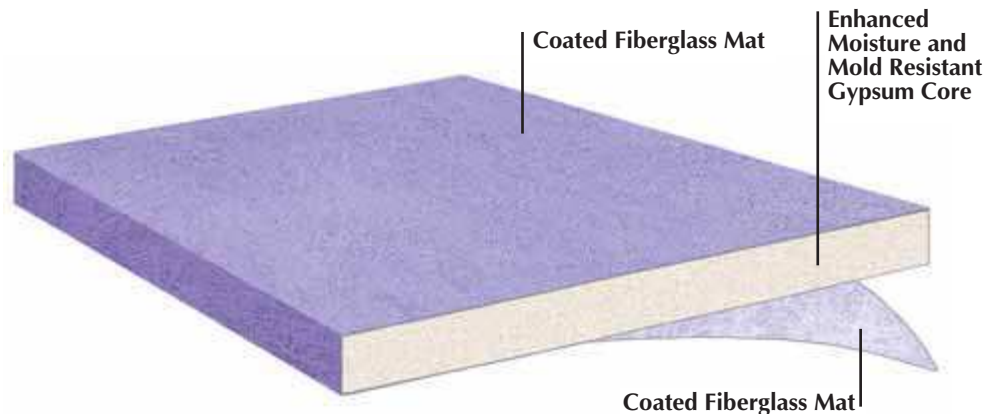

06 16 43

adequately maintained by the contractor and/or building owner.

- Do not laminate e²XP Sheathing to masonry surfaces, fasten to furring strips or framing.
- e²XP Sheathing is not intended for tile applications. For tile applications, PermaBase Cement Board is recommended.
- e²XP Sheathing is not a replacement for structurally engineered sheathings required for racking qualities, and should not be used in lieu of plywood when required.
- e²XP Sheathing application to framing by adhesive only is not recommended.
- Stud spacing must not exceed 24" o.c.
- All design details such as fasteners, sealants and control joints, per system specifications, must be properly installed. Openings and penetrations must be properly flashed and sealed according to code, building design and weather resistive barrier manufacturer's instructions. Failure to do so will void the warranty. (See e²XP Sheathing Warranty for terms, conditions and limitations.)

COMPOSITION & MATERIALS

e²XP Sheathing is manufactured with a moisture and mold resistant core and facer. The facer is composed of a coated fiberglass mat which provides superior weather resistant capabilities. e²XP Fire-Shield® Exterior Sheathing (Type X) has special additives in the core to enhance its fire-resistive properties.

e²XP Sheathing contains no asbestos.

SIZES AND TYPES

Fire-Shield:

1. Width: 4' (1219 mm)
2. Lengths: 8', 9' and 10' (2438 mm, 2743 mm, and 3048 mm)
3. Thickness: 1/2" Regular (12.7 mm)
5/8" Fire-Shield (15.9 mm)
4. Edges: Square

TECHNICAL DATA

PHYSICAL PROPERTIES	1/2" e ² XP	5/8" e ² XP
Nominal Width	4'	4'
Standard Lengths	8', 9', 10' ± 1/4"	8', 9', 10' ± 1/4"
Nominal Weight, lbs./msf	1,900	1,900
Bending Radius	6' ¹¹	6' ¹¹
Composition	Coated fiberglass mat/gypsum core	
Racking strength, ² lbs./f. (dry) (Ultimate - not design value)	>540	>654
Flexural Strength, ³ parallel, lbs. (4' weak direction)	80 ⁴	100 ⁴
Compressive Strength	Min. 500 psi	Min. 500 psi.
Humidified Deflection, ³ inches	1/8"	1/8" ¹⁵
Permeance ⁶ (perms) [ng/Pa•s•m ²]	22 [1260]	19 [1090]
"R" Value ⁷	.043	.050
Combustibility	Noncombustible	Noncombustible
Flame Spread, E84	5	5
Coefficient of Thermal Expansion ⁹ in/in/°F	9.26 x 10 ⁻⁶	9.26 x 10 ⁻⁶
Resists Growth of Mold ¹⁰	Yes	Yes
Handling Characteristic	Yes	Yes
Fasteners	Standard	Standard

1. Double fasteners on ends as needed.
2. Tested in accordance with ASTM E 72
3. Tested in accordance with ASTM C 473
4. Minimum requirements for ASTM C 1177
5. Maximum requirements for ASTM C 1396 and ASTM C 1177
6. Tested in accordance with ASTM E 96 (dry cup method)
7. Tested in accordance with ASTM C 518 (heat flow meter)
8. As defined and tested in accordance with ASTM E 136
9. Tested in accordance with ASTM E 228
10. Tested in accordance with ASTM D 3273

APPLICABLE STANDARDS

ASTM Specification C 1177 and application sections of C 1396.

FIRE RESISTANCE RATINGS

The 5/8" e²XP Fire-Shield Sheathing is tested in accordance with ASTM Standard E 119 and is classified as Type X for use in UL Listings.

INSTALLATION

APPLICABLE STANDARDS AND REFERENCES

ASTM C 1280
GYPSUM Association GA-253

RECOMMENDATIONS

- e²XP Sheathing must be installed in accordance with Gypsum Association with document GA-253, ASTM C 1280 or National Gypsum Co. *Gypsum Construction Guide*.
- e²XP Sheathing can be attached parallel or perpendicular to wood or metal framing. Use appropriate board orientation for specific fire assemblies and shear wall applications as required by the design.
- Framing members shall not vary more than 1/8" from the plane of the faces of adjacent framing.
- Fasteners should be driven flush with the panel surface (not countersunk) and into the framing. Locate fasteners at least 3/8" from the ends and edges of the sheathing. For wood studs: Nails should be galvanized, 11 gauge, 7/16" head, 1-3/4" long. Screws should be 1-1/4" bugle head, corrosion resistant Type W for wood and Type S for steel. Use appropriate fasteners for attaching e²XP Sheathing to framing.
- Install e²XP Sheathing with end joints staggered on horizontal applications. Ends and edges of the sheathing should fit snugly.
- The location of control joints shall be as required by either the building design or the manufacture of the specified exterior material.

JOINT TREATMENT

e²XP Sheathing is compatible with a variety of exterior systems. For applications requiring joint treatment, joint finishes must be compatible with the exterior system specified. Consult your weather/water resistant barrier manufacturer, cladding manufacturer or local building code authority to determine the appropriate joint treatments.

DECORATION

Soffit and Ceiling applications only

Embed 2" wide fiberglass mesh tape in ProForm® BRAND Sta-Smooth® Setting Compound or equivalent, over all joints. Once dry, apply a skim coat of Sta-Smooth Setting Compound or equivalent, over the panels to achieve a uniform, smooth finish over the entire area. Prime with exterior grade primer and finish with two coats of exterior grade paint.



e²XP Sheathing was introduced in March 2008 on a regional basis beginning in the Southeastern United States. For additional product and availability information go to:

WWW.PURPLECHOICE.INFO

National
Gypsum®

For additional information
Phone **1-800-NATIONAL**
(1-800-628-4662)

Conventional Plaster Systems



09 23 00

Kal-Kore BRAND Plaster Base

DESCRIPTION

Kal-Kore BRAND Plaster Base panels consist of a fire resistive gypsum core encased in blue absorptive face paper and liner paper on the back side. Although specifically designed as a base for veneer plaster, it also provides an excellent base for conventional basecoat plasters such as Gypsolite or Two-Way Hardwall.

TECHNICAL DATA

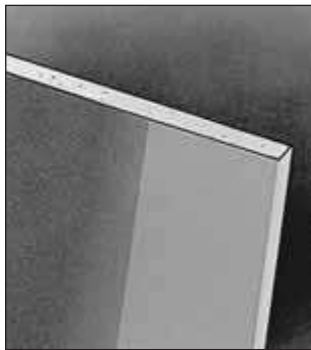

KAL-KORE PLASTER BASE

Kal-Kore is available in two basic types: Regular and Fire-Shield type X. Kal-Kore is 4' wide and is supplied in 8' through 16' lengths. Thicknesses are as follows:

Regular – 3/8" and 1/2".

Fire-Shield – 1/2" Fire-Shield C, 5/8" Fire-Shield, 5/8" Fire-Shield C, produced to meet ASTM C 1396.

Note: Installation of gypsum lath and metal lath shall be in accordance with ASTM C 841. Do not use 3/8" Kal-Kore plaster base with conventional basecoat plasters.

Conventional Plaster Accessories*

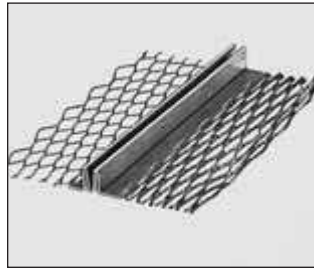

NO. 15 DOUBLE V EXPANSION JOINT

Minimizes cracking in large plaster areas. Also provides ground to ensure proper plaster thickness.

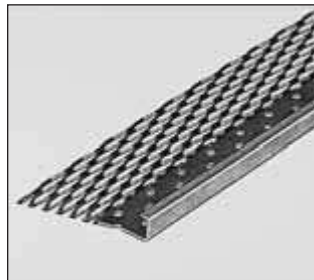

NO. 66 EXPANDED FLANGE SQUARE CASING

Has short, 90 degree return at plaster surface, serving as a plastering stop.

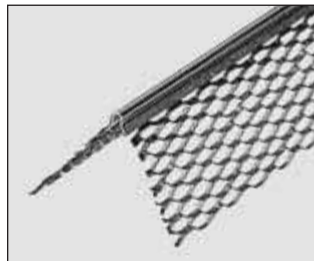

NO. 1 EXPANDED CORNERBEAD

The 2 1/2" expanded flange ends 1/4" from the nose of the bead providing reinforcement where needed most.

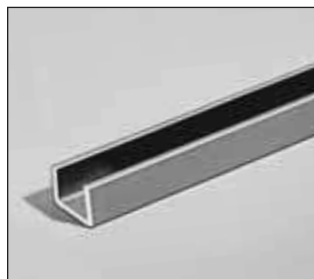

COLD ROLLED STEEL CHANNEL

Used as studs for attaching metal lath in 2" solid partitions. For furring or runners in suspended ceilings.

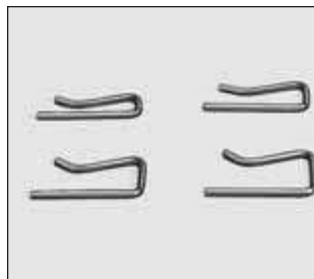

BEAM FURRING CLIP

Used to attach lath to flanges of steel beams, joists and columns. Tempered spring steel.



L RUNNER

Perforated – Ceiling or floor support for 2" solid lath and plaster partition.

Plain – Ceiling support for 2" solid board partition using 1" shaftliner.

Metal Lath*



DIAMOND MESH LATH

Used as a plaster base and reinforcement on almost all types of walls and ceilings, over wood or steel framing, flat or curved surfaces. Diamonds are 5/16" wide.



SELF-FURRING DIAMOND MESH LATH

Used extensively in stucco work, as a plaster reinforcement over interior masonry walls, and in steel column fireproofing. The self-furring dimples hold the metal lath 1/4" away from the surface to be plastered.

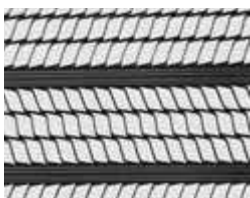

1/8" FLAT RIB LATH

Designed to meet the demand for rigid expanded metal lath used as a plaster base in all types of work. Widely used as reinforcement for basecoat in ceramic tile work. Sheets are reversible.

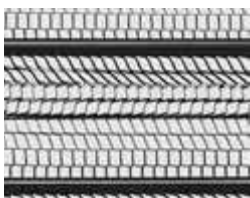

3/8" RIB LATH

The 3/8" rib lath is used for ceilings under steel joist construction and metal reinforced concrete floors. It is also recommended for concrete slab floors over steel joists.

DESCRIPTION

GOLD BOND BRAND TWO-WAY HARDWALL GYPSUM PLASTER

Gold Bond BRAND Two-Way Hardwall Plaster is a basecoat plaster which requires the job site addition of an aggregate and water to provide working qualities and is designed for interior use over all accepted plaster bases. It may be applied by hand or used through pump/spray plastering machines.

ADVANTAGES

Controlled Uniformity

Two-Way Hardwall Plaster is set-stabilized and adjusted for market requirements and seasonal changes. When mixed with sand or other aggregate it has uniform working qualities and excellent spread.

Strength

Two-Way Hardwall Plaster properly proportioned with aggregate forms a hard, durable base for the finish coat. Its high tensile and compressive strength results in increased resistance to minor structural movements, impacts and abrasions.

Fire Resistance

Two-Way Hardwall Plaster is essentially mineral in composition and will not support combustion.

Specification Reference

ASTM Designation C 28, "Gypsum Plasters".

Bag Weight

100 lbs. (45.4 kg)

TECHNICAL DATA

AGGREGATE PROPORTION AND ESTIMATED COVERAGE

Aggregate Pro- portions	Plaster Base (Sq. M./Metric Ton)	Coverage, Sq. Yds. per Ton (161-203)	Sq. Ft. (Sq. M.) per Bag (7-9)	Thick- ness In. (mm)
Sanded 1:2-1/2	Gypsum Lath	175-220 (161-203)	80-100 (7-9)	7/16" (11.1)
Sanded 1:2-1/2	Metal Lath	90-125 (83-115)	40-55 (4-5)	9/16"* (14.3)*
Sanded 1:3	Brick & Clay Tile Concrete Block	175-220 (161-203)	80-100 (7-9)	9/16" (14.3)

*Measured from face of lath.

NOTE: Sanded 1:2-1/2 means 1 part plaster to 2-1/2 parts sand by weight.

WEIGHT COMPARISON OF BASECOAT PLASTERS

Dry Set Mortar Weight	Sanded 1.3	Gypsolite Regular
Weight lbs. per cu. ft. (kg/m ³)	120 (1922)	50 (801)
Lbs./yd. ³ (kg/m ³) 3/8" (9.5 mm) thick	34 (18)	14 (8)
Lbs./yd. ³ (kg/m ³) 1/2" (12.7 mm) thick	45 (24)	19 (10)
Lbs./yd. ³ (kg/m ³) 5/8" (15.9 mm) thick	56 (30)	24 (13)
Lbs./yd. ³ (kg/m ³) 3/4" (19.0 mm) thick	67 (36)	29 (16)
Wet Mortar Weight		
Weight lbs. per cu. ft. (kg/m ³)	140 (2243)	69 (1105)

DESCRIPTION

GOLD BOND BRAND GYPSOLITE PLASTER

Gold Bond BRAND Gypsolite is a lightweight gypsum basecoat plaster mixed at the mill with correctly sized and proportioned perlite aggregate, requiring only the addition of water on the job. It is manufactured to be trowel-applied over gypsum or metal lath.

ADVANTAGES

Uniform Strength and Hardness

Uniformity is ensured through exact proportioning and thorough mixing of graded perlite and gypsum plaster at the mill. Gypsolite provides a uniform base for the finish coat.

Lightweight

Gypsolite weighs less than half as much as sanded gypsum plaster, thus reducing the dead-load on framing.

High Insulating Value

Gypsolite has a "k" factor of 1.5 which provides about 3 1/2 times the insulating value of sanded plaster.

TECHNICAL DATA

GYPSOLITE ESTIMATED COVERAGE

Plaster Base	Coverage, Sq. Yds. per Ton (Sq. M./Metric Ton)	Sq. Ft. (Sq. M.) per Bag (4-5)	Thickness In. (mm)
Gypsum Lath	140-155 (129-143)	50-55 (4-5)	7/16" (11.1)
Metal Lath	65-80 (60-74)	25-30 (2-3)	9/16"* (14.3)*

*Measured from face of lath.

LIMITATIONS

When used over metal lath, a sand float finish should be specified. A smooth-trowel finish is not recommended since the combination of a relatively soft (perlite aggregated) basecoat and a hard (smooth-trowel lime/gauging) finish has the potential for cracking and spalling of the finish coat.

Fire Resistance

Gypsolite has excellent fire-resistive qualities and generally provides fire ratings higher than sanded plaster.

Specification Reference

ASTM Designation C 28 for "Gypsum Plasters".

Bag Weight

80 lbs. (36.3 kg)

25 lbs. (11 kg)

Water Ratio

1.2 gallons of water per 25 lbs. of plaster.



PHYSICAL PROPERTIES OF BASECOAT PLASTERS (TYPICAL TEST RESULTS PER ASTM C 472)

Plaster Properties	Gypsolite Regular	Two-Way Hardwall						
		Gypsum Plaster to Sand by Weight			Gypsum Plaster and Vermiculite		Gypsum Plaster and Perlite	
		1:1	1:2	1:3	Regular	Masonry	Regular	Masonry
Mix	Mill Mix	1:1	1:2	1:3	100 lbs. (45.4 kg) 2 cu. ft. (.06 m ³)	100 lbs. (45.4 kg) 3 cu. ft. (.08 m ³)	100 lbs. (45.4 kg) 2 cu. ft. (.06 m ³)	100 lbs. (45.4 kg) 3 cu. ft. (.08 m ³)
Approximate Compressive Strength lbs. per sq. in. (kPa)	900 (6201)	1600 (11024)	1150 (7923)	750 (5168)	500 (3445)	300 (2067)	900 (6201)	650 (4479)
Approximate Tensile Strength lbs. per sq. in. (kPa)	160 (1102)	250 (1722)	190 (1309)	120 (827)	130 (896)	90 (620)	160 (1102)	100 (689)

Finish Plasters

DESCRIPTION

GOLD BOND BRAND GYPSUM GAUGING PLASTER (SUPER-WHITE)

Gold Bond BRAND Gauging Plaster, quick set or slow set type, is designed for use with finish lime. It is specially ground, calcined gypsum, which readily mixes with water and lime putty. Proper proportioning is essential, since gauging adds strength and hardness to the finish surface by reinforcing the plastic non-setting lime against shrinkage and cracking. A finish coat of gypsum gauging plaster and finish lime, job mixed 2 parts hydrated lime to 1 part plaster by weight, is designed primarily for interior smooth trowel application over a gypsum plaster basecoat. Smooth finish plasters should be applied at a thickness of not more than 1/16". Texture finishes should be applied at a thickness of not more than 1/8".

Complies with ASTM Designation C 28.

Bag Weight

Quick Set – 100 lbs. (45.4 kg) (50 lb. (22.7 kg) bags available in limited areas)

Slow Set – 100 lbs. (45.4 kg) (50 lb. (22.7 kg) bags available in limited areas)

TECHNICAL DATA

GYPSUM GAUGING PLASTER

Method of Application	Coverage*
Trowel Finish	1000-1400 sq. yds./Ton (921-1290 m ² /Metric Ton) 225-315 sq. ft./bag (21-29 m ² /Bag)

*With the addition of two tons of hydrated lime.

MILL-MIXED FINISH PLASTERS*

Product	Method of Application	Coverage*
Kal-Kote Smooth Finish	Trowel	650-750 sq. yds./Ton (598-645 m ² /Metric Ton)
Kal-Kote Texture Finish	Trowel	650-750 sq. yds./Ton (598-645 m ² /Metric Ton)
Uni-Kal and X-KALibur	Trowel	600-665 sq. yds./Ton (553-613 m ² /Metric Ton)

*See page 46 for additional information.

GOLD BOND BRAND GYPSUM MOULDING PLASTER (SUPER-WHITE)

Gold Bond BRAND Moulding Plaster is a very white, finely ground gypsum, primarily used for all kinds of ornamental plaster work. Because of its low expansion, excellent strength and hardness, it is specially adaptable for casting in rubber, gelatin and other types of moulds. For casting purposes, only water is added. For run-in-place ornamental work, such as cornices, the moulding plaster is used with lime putty, mixed 2 parts lime to 1 part moulding plaster by weight.

Complies with ASTM Designation C 59.

Bag Weight

100 lbs. (45.4 kg) (50 lbs. (22.7 kg) available in limited areas)

Note: Application of plaster shall be in accordance with ASTM C 842.

Water Ratio

6.5 gallons of water per 100 lb. bag.

MILL-MIXED FINISH PLASTERS

For a mill-mixed finish plaster, use Kal-Kote Smooth Finish, Kal-Kote Texture Finish Plaster, Uni-Kal or X-KALibur Extended Set Veneer Plaster. Requires the addition of water only. See page 46.

GYPSUM MOULDING PLASTER

Method of Application	Coverage*
Trowel Finish	1000-1400 sq. yds./Ton (921-1290 m ² /Metric Ton) 225-315 sq. ft./bag. (21-29 m ² /Bag)

*With the addition of two tons of hydrated lime.

PAINTING PLASTER

Various job conditions such as suction differences, wet or only partially dry walls, and reactions between paint and lime have caused unsatisfactory paint finishes, particularly on new construction.

Alkali-resistant primers specifically formulated for use over new plaster will permit decorating with oil or latex type paints.

Quality paint products should be used and manufacturers' recommendations followed. Finished plaster should be painted or covered to conceal possible discoloration. The paint system should be suitable for use over plaster surfaces that contain lime, which has a high pH of 10-13.

It is essential that plaster be sound and completely dry before painting. Conventional plaster may require 30 to 60 days to fully dry.



DESCRIPTION

ATTACHMENT OF GYPSUM PLASTER BASE TO HORIZONTAL AND VERTICAL WOOD SUPPORTS

Note: Application of Gypsum Plaster Base shall be in accordance with ASTM C 841.

Apply all Gypsum Plaster Base with long dimensions at right angles to the wood studs or supports. End joints shall occur on different supports in different courses and shall not be nearer than one full stud space from edges of openings in walls or partitions.

Gypsum Plaster Base shall be applied face side out and attached to wood framing with nails or staples.

Control joints should be installed in ceilings without perimeter relief with a maximum distance between such joints of 30' with a maximum undivided area of 900 sq. ft. With perimeter relief, maximum distance is 50' with maximum undivided area of 2500 sq. ft. On side walls control joints should be installed every 30'.

TECHNICAL DATA

MAXIMUM SPACING OF PLASTER BASE

Thickness of Plaster Base	Distance Between Supports	Number of Attachments per Bearing	Approximate Spacing c to c of Attachments
3/8" (9.5 mm)	16" (406 mm)	4	5" (127 mm)
1/2" (12.7 mm)	24" (609 mm)	4	5" (127 mm)

NAILS AND STAPLES* MINIMUM GAUGE REQUIREMENTS

Attachments	Thickness of Plaster Base	Length of Leg	Depth of Support Penetration	Diameter of Flat Head or Blued Nails or Crown Width of Staples*	Gauge of Shank of Nails or Staples*
Nails	3/8" (9.5 mm)	1 1/8" (28.6 mm)	3/4" (19.0 mm)	19/64" (7.5 mm)	13
Staples*		1" (25.4 mm)	5/8" (15.9 mm)	7/16" (11.1 mm)	16
Nails	1/2" (12.7 mm)	1 1/4" (31.8 mm)	3/4" (19.0 mm)	19/64" (7.5 mm)	13
Staples*		1 1/8" (28.6 mm)	5/8" (15.9 mm)	7/16" (11.1 mm)	16

*Galvanized staples.

2" SOLID-METAL LATH CHANNEL STUD SYSTEM

Gypsum Finish Plaster

Sanded Gypsum Plaster

Metal Lath

L Runner

CR Channel Stud

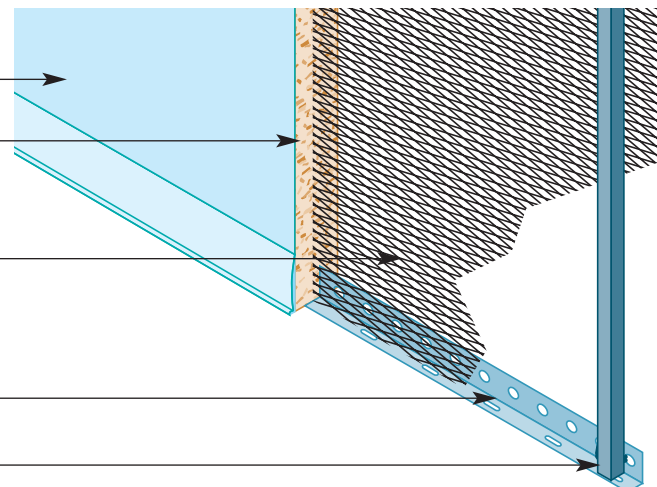

DESCRIPTION

This partition with C.R. channel as studs gives fire protection, stability and sound insulation while occupying a minimum amount of floor and building space. The system consists of three metal units (channel stud, metal lath, L runners) which are used together with Diamond Metal Lath and Gypsum Plaster. These components form a space-saving, strong, non-load-bearing partition for use in interior wall construction.

ADVANTAGES

Space Saving

Occupies less than half the space of conventional wood-stud or masonry constructed partitions.

Cost Saving

Simple erection cuts labor costs. One mechanic can quickly erect the channel studs and tie on Diamond Mesh Metal Lath.

Fire Protection

Composed of gypsum plaster and steel, it makes an excellent fire barrier. Official tests give the partition a one- to two-hour fire rating.

Sound Insulation

Partition is an effective sound barrier and has a Sound Transmission Class of 37 for 2" thick with sand, 33 for 2 1/2" thick with perlite aggregate.

Strength

The completed partition is a monolithic slab of gypsum plaster thoroughly reinforced with expanded metal lath and securely anchored to floor and ceiling. It is highly resistant to tension, impact, shear and vibration.

Adaptability

Partitions will accommodate door bucks of various types, casings, switch boxes and electrical outlets; also support lightweight fixtures such as kitchen cabinets.

LIMITATIONS

Refer to table of Permissible Partition Heights on page 38.

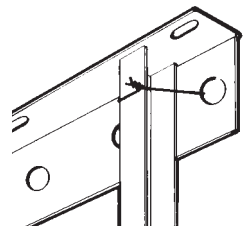

L RUNNER AT CEILING

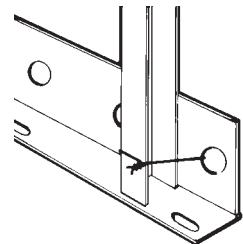

L RUNNER AT FLOOR

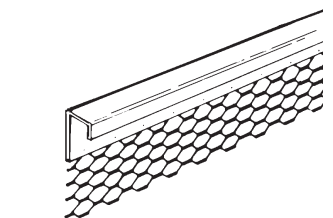

66 CASING BEAD

TECHNICAL DATA

SPACING OF VERTICAL SUPPORTS FOR ATTACHMENT

Type of Lath	Maximum Spacing of Supports	Weight Lbs. per Sq. Yd. (kg/m ²)
Diamond Mesh Lath	16" (406 mm)	2.5 (0.6 kg)
Flat Rib Lath	16" (406 mm)	3.4 (1.9 kg)
3/8" (9.5 mm) Rib Lath	16" (406 mm)	2.75 (1.5 kg)
	24"* (610 mm)	3.4 (1.9 kg)

*This spacing permissible for solid partitions not exceeding 16' (4877 mm) in height.

PERMISSIBLE PARTITION HEIGHTS (BASED ON L/240)

Maximum Unsupported Height	Face-to-Face Plaster Thickness	Size and Weight of Channels (per 1000') (305 m)
12' (3658 mm)	2" (51 mm)	3/4" (19.0 mm) 300 lbs. (136 kg)
14' (4267 mm)	2 1/4" (57.2 mm)	3/4" (19.0 mm) 300 lbs. (136 kg)
16' (4877 mm)	2 1/2" (63.5 mm)	3/4" (19.0 mm) 300 lbs. (136 kg)
18' (5486 mm)	2 3/4" (69.9 mm)	1 1/2" (38.1 mm) 475 lbs. (215 kg)

DETAILS

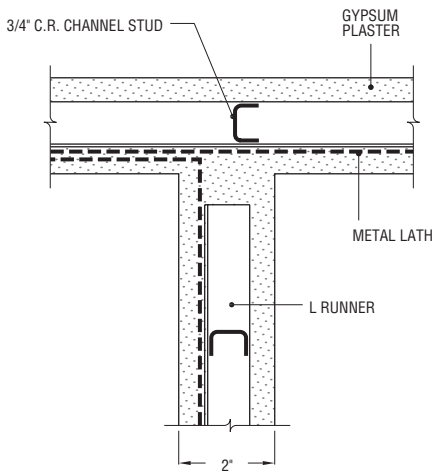

INTERSECTING PARTITION

09210A
Scale: 3" = 1'-0"

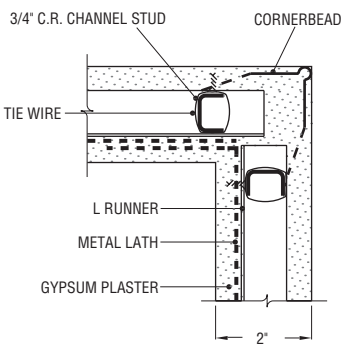

CORNER DETAIL

09210B
Scale: 3" = 1'-0"

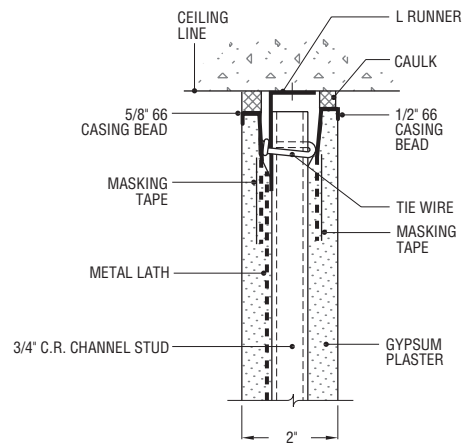

CEILING DETAIL

09210C
Scale: 3" = 1'-0"

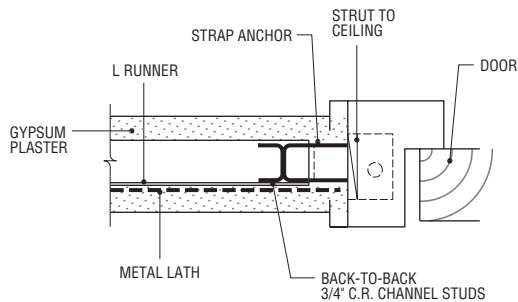

METAL DOOR FRAME

09210D
Scale: 3" = 1'-0"

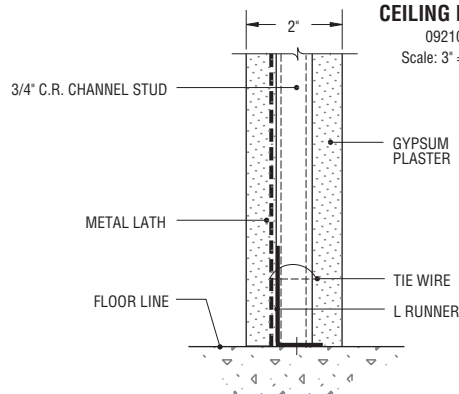

BASE DETAIL

09210E
Scale: 3" = 1'-0"

Fireproofing Columns and Beams with Metal Lath

DESCRIPTION

Gypsum plaster, mixed with sand or lightweight aggregate, is applied over a metal lath base providing an economical fire protective covering for structural steel columns.

ADVANTAGES

Lightweight

This system of fireproofing weighs only half as much as tile and one quarter as much as standard concrete for equivalent fire resistive ratings. This means a reduction of up to 1/3 in dead-load weight, reducing the size and cost of footings, foundations and structural framing.

Fire Resistance

Fire resistance ratings up to four hours can be obtained.

Economy

Lath is low in cost, quick and easy to apply, thereby effecting savings in material and labor costs.

LIMITATIONS

In warehouses or other occupancies where columns might be damaged, angle iron guards are recommended to protect column corners to the necessary height.

DETAILS

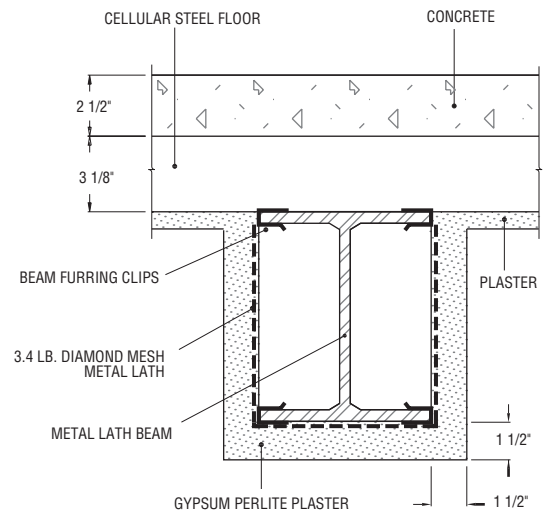

BEAM-3 HOUR

09210J

Scale: 1 1/2" = 1'-0"

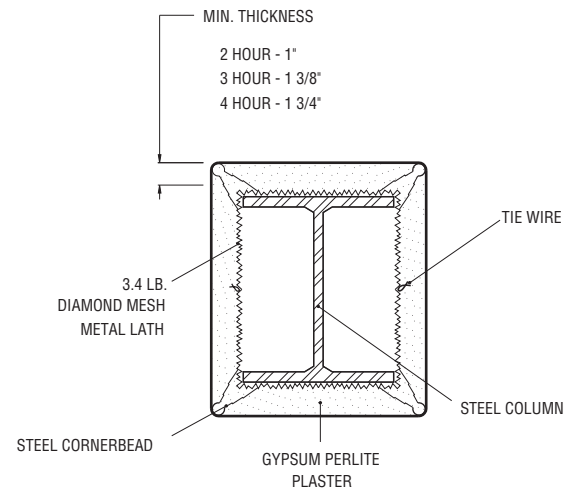
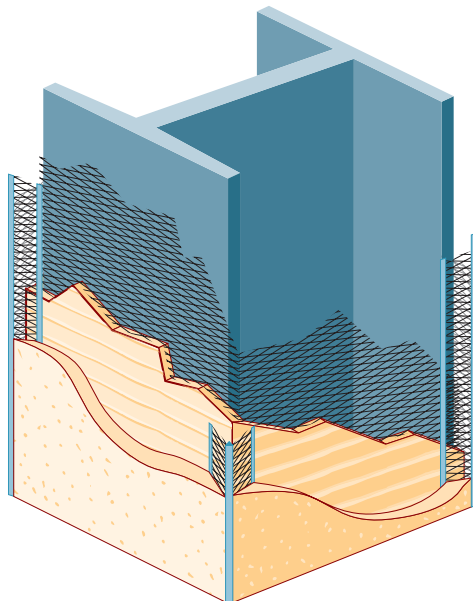

COLUMN - UL X402

09210J1

Scale: 1 1/2" = 1'-0"

09 23 00

Suspended Metal Lath Ceilings

DESCRIPTION

Metal lath suspensions are commonly made below virtually all types of construction for fire-rated and non fire-rated plaster ceilings. Framing of 1 1/2" C.R. channels are spaced up to 4' o.c. perpendicular to joists and are cross-furred with 3/4" C.R. channels spaced according to specifications for types and weight of metal lath. Lath is then properly lapped at sides and ends and tied every 6" to the 3/4" channel.

Where it is advisable to install unrestrained ceilings, having perimeters separated from adjacent walls or partitions, galvanized casing beads

should be installed around the periphery. Metal Lath is frequently used for furred as well as suspended ceilings. Metal lath is used for furring from wood, concrete and steel joists.

RECOMMENDATIONS

1. Control joints should be installed in ceilings without perimeter relief with a maximum distance between such joints of 30' with a maximum undivided area of 900 sq. ft. With perimeter relief, maximum distance is 50' with maximum undivided area of 2500 sq.ft.
2. Use three-coat plastering on metal lath.

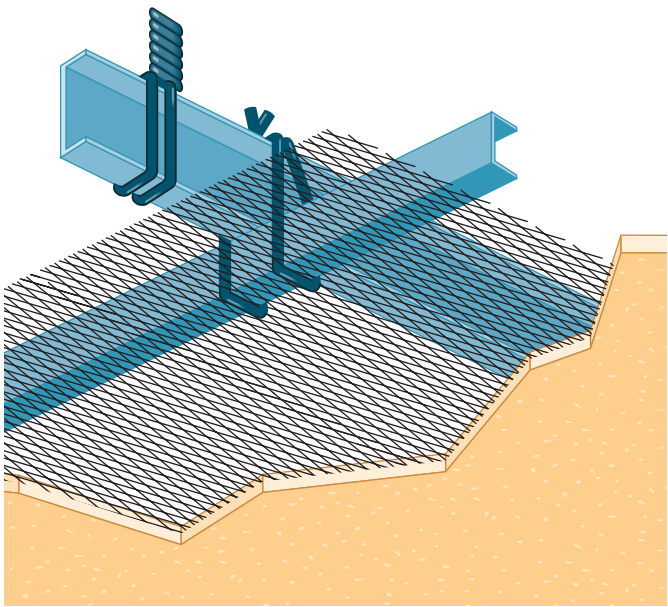

TECHNICAL DATA

SIZE AND SPACING OF CHANNEL FOR SUSPENDED CEILINGS

Center to Center Spacing of Hangers Along Channel	Size of Cold Rolled Channel	Main Channel (weight per 1000 ft.) (305 M)	Maximum Center to Center Spacing of Channel
up to 3' (914 mm)	1 1/2" (38.1 mm)	475 lbs. (216 kg)	4' (1219 mm)
up to 3'6" (1067 mm)	1 1/2" (38.1 mm)	475 lbs. (216 kg)	3'6" (1067 mm)
up to 4' (1219 mm)	1 1/2" (38.1 mm)	475 lbs. (216 kg)	3' (914 mm)

SIZE AND SPACING OF CHANNEL FOR FURRED AND SUSPENDED CEILINGS

Center to Center Spacing of Hangers	3/4" (19.0 mm) C.R. Channel Cross Furring 300 lbs. (136 kg)/1000 ft. (305 M)	Maximum Furring Spacing
up to 3' (914 mm)	3/8" (9.5 mm) rib lath	24" (610 mm)
up to 3' (914 mm)	3.4 lb. (1.5 kg) flat rib lath	19" (483 mm)
up to 3'6" (1067 mm)	3.4 lb. (1.5 kg) mesh lath	16" (406 mm)
up to 4' (1219 mm)	2.5 lb. (1.1 kg) mesh lath	12" (305 mm)

MAXIMUM SPACING OF SUPPORTS FOR METAL LATH

Type of Lath	Support Spacing	Weight of Lath lbs. per sq. yd. (kg/m ²)
Diamond Mesh (flat expanded)	16" (406 mm)	3.4 (1.9)
Flat Rib	16" (406 mm)	2.75 (1.5)
	19" (483 mm)	3.4 (1.9)
3/8" (9.5 mm) Rib	24" (610 mm)	3.4 (1.9)

DETAILS

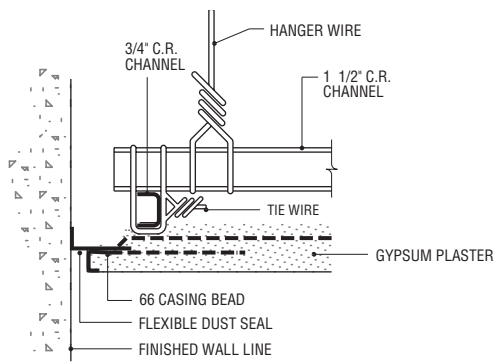

SUSPENDED METAL LATH AT WALL (UNRESTRAINED)
09210K
Scale: 3' = 1'-0"

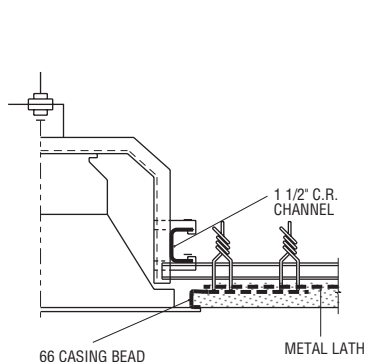

LIGHTING TROFFER
092100
Scale: 1 1/2' = 1'-0"

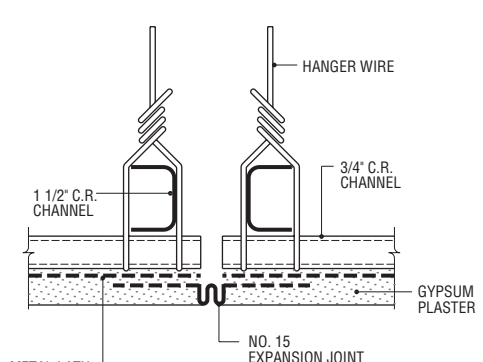

SUSPENDED METAL LATH CONTROL JOINT
09210M
Scale: 3' = 1'-0"

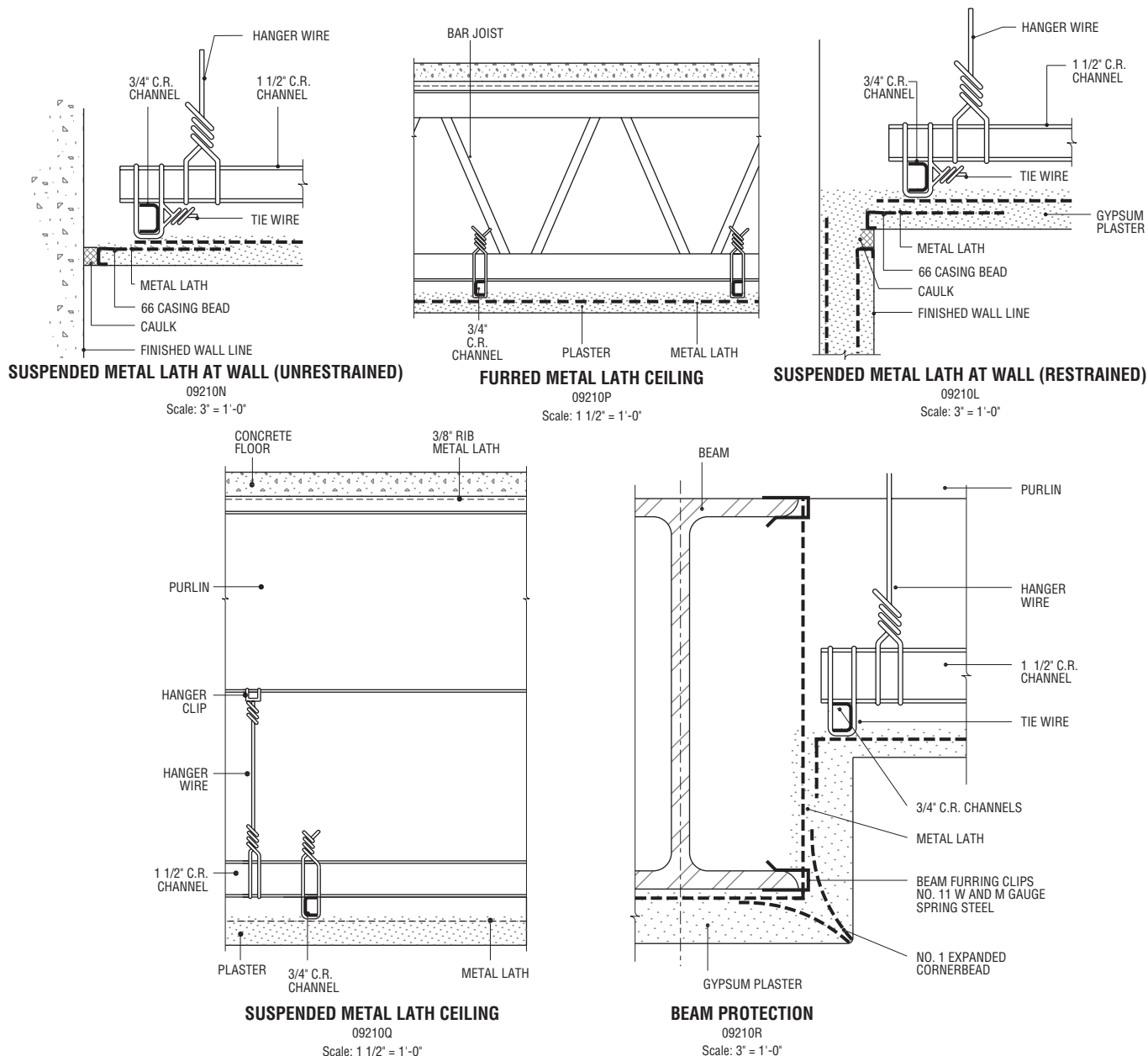

SPECIFICATIONS

SECTION 09 23 00

GYPSON PLASTERING

THE FOLLOWING PARAGRAPHS ARE FOR INSERTION INTO SECTIONS OF GENERIC SPECIFICATIONS OR GENERIC/PROPRIETARY SPECIFICATIONS COVERING GYPSUM PLASTER PRODUCTS. THE NATIONAL GYPSUM COMPANY PRODUCT NAME FOLLOWS THE GENERIC DESCRIPTION IN PARENTHESES.

PART 1 GENERAL

1.02 REFERENCES

- A. American Society for Testing and Materials (ASTM):
 1. C 28, Specification for Gypsum Plasters.
 2. C 59, Specification for Gypsum Casting and Molding Plaster.
 3. C 1396, Specification for Gypsum Board (Gypsum Base for Veneer Plaster).

4. C 841, Specification for Application of Interior Lathing and Furring.
5. C 842, Specification for Application of Interior Gypsum Plaster.

PART 2 PRODUCTS

2.02 MATERIALS

A. Gypsum Plaster Base:

1. Regular: A gypsum core lathing board surfaced with absorptive paper on front, and long edges and complying with ASTM C 1396 (Kal-Kore BRAND Plaster Base).
 - a. Thickness: 1/2"
 - b. Width: 4'
 - c. Length: 8' through 16'
 - d. Edges: Tapered

09 23 00

2. Fire-Resistant: A gypsum core lathing board with additives to enhance the fire resistance of the core and surfaced with absorptive paper on front, and long edges and complying with ASTM C 1396, Type X.
 - a. Thickness: 1/2" (Kal-Kore BRAND Fire-Shield C Plaster Base) or 5/8" (Kal-Kore BRAND Fire-Shield and Fire-Shield C Plaster Base).
 - b. Width: 4'
 - c. Length: 8' through 16'
 - d. Edges: Tapered
 3. Regular, Foil-Backed: A gypsum core lathing board surfaced with absorptive paper on front, and long edges; backed with aluminum foil; and complying with ASTM C 1396 (Kal-Kore BRAND Foil-Back Plaster Base).
 - a. Thickness: 1/2"
 - b. Width: 4'
 - c. Length: 8' through 16'
 - d. Edges: Tapered
- B. Gypsum Plaster:
1. Base Plaster: Gypsum neat plaster complying with ASTM C 28 (Gold Bond BRAND Two-Way Hardwall Gypsum Plaster).
 2. Base Plaster: Gypsum plaster with mill-mixed perlite aggregate complying with ASTM C 28 (Gold Bond BRAND Gypsolite Plaster).
 3. Finish Plaster: Gypsum gauging plaster complying with ASTM C 28 (Gold Bond BRAND Super-White Gauging Plaster Quick Set and Gold Bond BRAND Super-White Gauging Plaster Slow Set).
 4. Finish Plaster: Gypsum moulding plaster complying with ASTM C 59 (Gold Bond BRAND Super-White Moulding Plaster).
 5. Finish Plaster: Gypsum plaster for smooth finish complying with ASTM C 587 (Kal-Kote BRAND Smooth Finish Plaster).
 6. Finish Plaster: Gypsum plaster for textured finish complying with ASTM C 587 (Kal-Kote BRAND Texture Finish Plaster).
 7. Finish Plaster: Gypsum plaster for smooth finish complying with ASTM C 587 (Uni-Kal BRAND Veneer Plaster).
 8. Finish Plaster: Gypsum plaster for smooth finish with extended set time complying with ASTM C 587 (X-KALibur BRAND Veneer Plaster).

PART 3 EXECUTION

3.01 INSTALLATION

- A. Metal Lath, Gypsum Plaster Base, and Accessories: In accordance with ASTM C 841.
- B. Gypsum Plaster: In accordance with ASTM C 842 and the manufacturer's recommendations, National Gypsum Company "Gypsum Construction Guide."
- C. Tolerances: For flatness of surface, do not exceed 1/4" in 8' for bow or warp of surface and for plumb and level.

RECOMMENDATIONS

BASECOAT PLASTER PROCEDURES

Two-Coat Work

Apply first coat with firm pressure to form good bond on the Gypsum Plaster Base or masonry base; then immediately double back (without cross-raking first coat) using material of same proportion to build proper basecoat thickness. Straighten to a true surface (without applying water) to receive the second (finish) coat.

Surface should be left sufficiently rough and porous to provide suitable bond of the finish coat.

Three-Coat Work

"Scratch" – "brown" – finish is generally used for metal lath or masonry bases, and is performed in discrete steps.

- Scratch (first) coat: Should be applied with sufficient material and pressure to obtain good bond over solid bases or form full keys through metal lath. Provide suitable material thickness for scratching (raking) to obtain good mechanical keying of the "brown" coat.
- Brown (second) coat: Shall be applied after the scratch (first) coat has set hard and still damp. Apply to give mass and surface as for double-back in two-coat work.

Finish Coat Plaster Procedures

General Requirements (Basecoat Condition)

Application over a partially dry basecoat is preferred. If basecoat is thoroughly dry, wet with even application of water to a semi-dry condition. Avoid excess water. Do not apply finish to basecoats having free water on the surface.

Application – Gauged Lime Putty Trowel Finish

Smooth Finishes

- Scratch in tightly over the basecoat, covering the surface completely, then double back immediately with material from the same gauge, filling out to a true, even surface with total thickness of not more than 1/16".
- Allow finish to "draw" (lose moisture to basecoat and ambient air) and firm up – then trowel it well to compact and close the surface under the edge of the trowel. Dash water on the surface for lubrication and development of soft material along trowel's edge to fill surface depressions or other blemishes.
- When finish plaster setting action is under way, a second (final) water troweling can be done with strong pressure to obtain a polished surface if desired.

Texture Finishes

- Apply finish as above to a true, even surface with total thickness not more than 1/8".
- Allow finish to "draw" (lose moisture to basecoat and ambient air). Then begin floating, texturing, or skip troweling to achieve desired texture. Additions of clean graded silica may be required to achieve desired texture.

Drying

Conventional plaster systems should be allowed to dry 30 days minimum under ambient conditions prior to final decoration. Variances in humidity or poor drying conditions may affect the drying process.

Storage

Gypsum plaster must be kept dry before use. Storage conditions vary with location and seasonal changes, which may affect storage life. These conditions may affect product characteristics such as setting time, working qualities, component separation, or lumping, etc. Such aging is normally a function of exposure to humid air, temperature, and physical support in warehousing. Adverse storage conditions or prolonged storage may affect the working qualities of the product. Rotate inventory frequently for best results.



For additional information
Phone 1-800-NATIONAL
(1-800-628-4662)

Veneer Plaster Systems



09 26 13

VENEER PLASTER SYSTEMS



Veneer plaster expands architectural design limits as with this curved vaulted ceiling.



Kal-Kore boards are screwed to steel studs or nailed or screwed to wood studs to form a base.

DESCRIPTION

Veneer Plaster Systems consist of a 4' wide gypsum plastering base with a special, highly absorptive paper surface that is covered with thinly troweled, special purpose plasters. Two basic types of veneer plaster are available: Uni-Kal and X-KALibur, which are one-coat plaster system products; and Kal-Kote, a two-coat plaster system. The gypsum plaster base, Kal-Kore, is erected in the same manner for both systems. Both veneer plaster systems can be specified for virtually all types of partition and ceiling constructions including wood or steel framing or furring and masonry. For both residential and commercial buildings, either type of veneer plaster system produces a wall more nail-pop resistant than drywall and, when properly installed, more crack resistant than conventional lath and plaster.

ADVANTAGES - GENERAL

The advantages of veneer plaster over other commonly used partition and ceiling systems include:

1. Rapid installation which reduces overall construction time.
2. Appearance and surface of conventional plaster at lower cost than regular plastering.

3. High resistance to cracking, nail-popping, impact and abrasion failure.
4. Mill-mixed plaster components help ensure uniform installation performance and finished job quality.

ADVANTAGES - ONE-COAT SYSTEM (UNI-KAL/X-KALIBUR)

1. Requires only one plastering material on the job.
2. Slightly lower in-place cost than two-coat system.
3. Can be applied directly to concrete block.
4. X-KALibur is formulated to have extended set characteristics beyond traditional Uni-Kal setting times.

ADVANTAGES - TWO-COAT SYSTEM (KAL-KOTE)

1. Kal-Kote System may be used for plaster-embedded electric radiant heating cable systems.
2. Same application techniques as for conventional plaster.
3. Greater crack resistance than one-coat systems.
4. Can be applied directly to concrete block.

LIMITATIONS

1. Not recommended for exterior use or where subject to weathering, direct water contact or temperature exceeding 125°F (52°C) for extended periods of time.
2. Framing spacing is limited and partition heights are reduced in comparison with some standard constructions.

3. Provides less rigidity than similar standard plaster systems.
4. When Uni-Kal/X-KALibur will be applied, do not install Kal-Kore too far in advance of plastering since Uni-Kal/X-KALibur bond can be adversely affected if face of Kal-Kore has become faded from light. If Kal-Kore has been faded, apply Kal-Kote Base Plaster or a bonding agent to obtain good bond.
5. All are designed for trowel application. Gold Bond Veneer Plasters are not suitable for conveyance or application by conventional plastering machines.
6. Compared to conventional plasters, Veneer Plaster Systems are more subject to beading (ridging) and cracking at the joints under rapid drying conditions such as those caused by low humidity, high temperature and/or high draft exposure.
7. All provide a base over which paints or other finishes should be applied.
8. Do not use a polyethylene vapor retarder unless structure is ventilated adequately during application of veneer plasters.
9. A bonding agent must be applied to monolithic concrete prior to application of either system.
10. Mix only full bags of plaster for proper set.
11. Do not use self-adhesive mesh tape.



Joints are reinforced with Kal-Mesh fiberglass webbing. Steel corner and casing beads protect corners.



Kal-Kote is applied in 2 coats, a base and a finish, to form a hard-surfaced, 1/8" total thickness.

TECHNICAL DATA

GOLD BOND® BRAND KAL-KORE PLASTER BASE

Kal-Kore is a tapered edge gypsum plaster base having a blue absorptive face paper surface designed to permit rapid trowel application and strong bond of Kal-Kote, Uni-Kal and X-KALibur plasters. Also available foil backed or Fire-Shield (type X). Kal-Kore is manufactured to conform to ASTM Specification C 1396 and CSA A82.27.

GOLD BOND® BRAND HI-ABUSE KAL-KORE PLASTER BASE

Gold Bond BRAND Hi-Abuse Kal-Kore Fire-Shield Type X Plaster Base boards consist of a fire resistive Type X gypsum core encased in a heavy, blue absorptive face paper designed to permit rapid trowel application and strong bond of Uni-Kal veneer plaster and strong liner paper on the back side. Gold Bond BRAND Hi-Abuse Kal-Kore Fire-Shield Type X Plaster Base features a specially formulated core to provide fire resistance ratings when used in tested systems as well as greater resistance to surface indentation. Long edges of the boards are tapered to allow joints to be reinforced and concealed with Kal-Mesh Tape and Uni-Kal Plaster. Gold Bond BRAND Hi-Abuse Kal-Kore Fire-Shield Type X Plaster Base is manufactured to conform to ASTM Specification C 1396 and Federal Specification SS-L-30D Type VI Grade X (Fire-Shield).

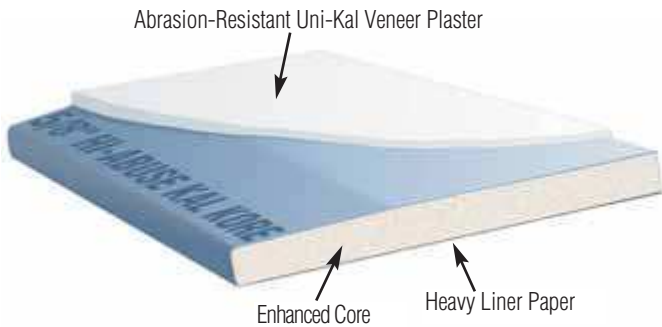

Size	Thickness	Edge	Pcs. per Bdl.
4'x8', 16' (1219 mm x 2438 mm, 4877 mm)	3/8" (9.5 mm)	Square or Tapered	2
4'x8', 16' (1219 mm x 2438 mm, 4877 mm)	1/2" (12.7 mm) 1/2" (12.7 mm) FSK-C	Square or Tapered	2
4'x8', 16' (1219 mm x 2438 mm, 4877 mm)	5/8" (15.9 mm) FSK	Square or Tapered	2
4'x8', 12' (1219 mm x 2438 mm, 3657 mm)	1/2" (12.7 mm) 5/8" (15.9 mm) FSK Hi-Abuse	Square or Tapered	2

09 26 13

KAL-KOTE BRAND BASE PLASTER

Kal-Kote Base Plaster is a specially designed high strength basecoat plaster for application 1/16" minimum thickness over Kal-Kore, masonry or monolithic concrete that has been treated with a bonding agent.

Strength of Kal-Kote Base is substantially greater than that exhibited by typical sanded basecoat plaster.

Fire Resistance

Fire ratings equivalent to those of drywall systems can be obtained by applying the corresponding Kal-Kore type and thickness over the same framing member size and spacing, with the same fasteners. The total plaster thickness should be a minimum of 1/8". The minimum 1/8" thickness is achieved by applying a finish not exceeding 1/16" over 3/32" of Kal-Kote Base Plaster.

Specification Reference

ASTM Designation C 587.

Bag Weight

80 lbs. (36.3 kg)

Water Ratio

10-12 quarts per bag

Coverage (est.)

1/16" on Kal-Kore Base, 425-475 sq. yds. per ton (150-170 sq. ft. per bag). One coat to level over masonry, 225-275 sq. yds. per ton (80-100 sq. ft. per bag).

KAL-KOTE BRAND SMOOTH FINISH PLASTER

Kal-Kote Smooth Finish is designed to provide a white smooth trowel finish using conventional plastering techniques. Apply not exceeding 1/16" over Kal-Kote Base.

Requires the addition of water only. It may also be used as a finish for conventional basecoat plasters. Small amounts of commercial retarder may be cautiously used to slow the setting time when used over conventional basecoat plasters.

Bag Weight

50 lbs. (22.7 kg)

Water Ratio

18-20 quarts per bag

Coverage (est.)*

1/16" coat troweled on Kal-Kote Base Plaster, 650-700 sq. yds. per ton (145-160 sq. ft. per bag).

KAL-KOTE BRAND TEXTURE FINISH PLASTER

Kal-Kote Texture Finish is designed to provide a variety of decorative surfaces using common plastering techniques. Applied as a 1/16" finish coat over Kal-Kote Base. It requires the addition of water only.

Bag Weight

50 lbs. (22.7 kg)

Water Ratio

11-12 quarts per bag

Coverage (est.)*

1/16" coat troweled on Kal-Kote Base Plaster, 650-700 sq. yds. per ton (145-160 sq. ft. per bag).

UNI-KAL AND X-KALIBUR BRAND VENEER PLASTER

Uni-Kal and X-KALibur are single component veneer plasters for application over tapered edge 1/2" Regular or 5/8" Fire-Shield Kal-Kore, 5/8" Kal-Kore Hi-Impact or as a finish coat over Kal-Kote base. When applied in a thin coat 3/32" thick and troweled to a smooth finish, they provide a durable, abrasion-resistant surface for further decoration. X-KALibur has a longer extended working time.

Uni-Kal and X-KALibur may be worked to a variety of textured finishes.

Uni-Kal and X-KALibur applied not exceeding 1/16" may be used as a finish coat over a 3/32" coat of Kal-Kote Base Plaster for a total minimum thickness of 1/8".

Strength of Uni-Kal and X-KALibur provides a surface resistant to abrasion, cracking and nail-pops.

Fire Resistance

Fire ratings equivalent to those of drywall systems can be obtained by applying the corresponding Kal-Kore type and

thickness over the same framing member size and spacing with the same fasteners and 3/32" of Uni-Kal or X-KALibur.

Specification Reference

ASTM Designation C 587.

Bag Weight

50 lbs. (22.7 kg)

Water Ratio

13-15 quarts per bag

Coverage (est.)*

3/32" on Kal-Kore Base, 600-665 sq. yds. per ton (135-150 sq. ft. per bag). One coat to level over masonry, 300-350 sq. yds. per ton (70-80 sq. ft. per bag).

*Coverage estimates are approximately the same as over Kal-Kore Base Board for conventional plasters.

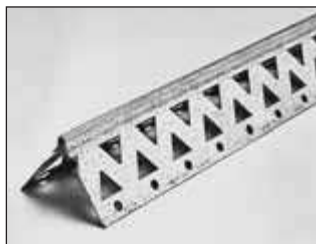

KAL-KORNER BEAD
Formed of galvanized steel to protect exterior corners with veneer plastering. Flange length 1 1/4" .



E-Z STRIP® CONTROL JOINT
Designed for drywall or veneer plaster systems. A vinyl extrusion used as an expansion or control joint for ceilings or partitions.



EXPANDED VENEER CORNERBEAD
Used as an alternate to the Kal-Korner Bead for exterior corners. 1 1/4" flanges.



KAL-MESH TAPE
A coated non-adhesive fiberglass tape which is stapled to Kal-Kore to reinforce all joints and interior angles.

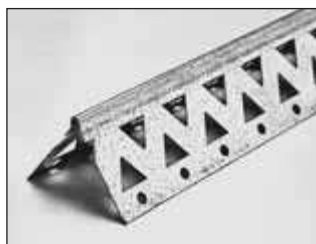

ARCH CORNERBEAD
Can be used straight for exterior corners or flanges, or may be snipped and bent to form arches.



.093 ZINC CONTROL JOINT
Designed as an expansion or control joint for ceiling and partition areas for both drywall or veneer plaster systems.



VENEER J TRIM CASING BEAD
Used as a finished edge at door and window jambs by slipping over edge of plaster base.



1 1/2" DRYWALL FURRING CHANNEL CLIP
Attaches Screw Furring Channel to 1 1/2" cold rolled steel channel.

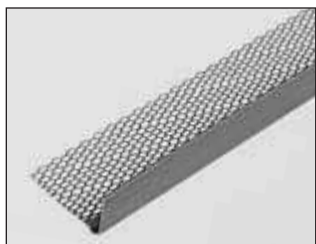

VENEER L TRIM CASING BEAD
Used as a finished edge at door and window jambs.

*Metal products are not manufactured by National Gypsum Company.

09 26 13

FASTENERS FOR ATTACHING KAL-KORE

Framing	Kal-Kore	Fastener	Fastener Spacing
Steel Studs & Furring	1/2" (12.7 mm)	Type S Screws 1" (25.4 mm) for single layer	12" o.c. Max. (305 mm)
	5/8" (15.9 mm)	1 5/8" (41.3 mm) for two-ply	
	3/8" (9.5 mm)	1 1/4" (31.8 mm) annular or 4d box nails**	Ceiling 7" o.c. (178 mm) Max.
Wood Framing	1/2" (12.7 mm)	1 1/4" (31.8 mm) annular or 5d box nails**	Sidewall 8" o.c. (203 mm) Max.
	5/8" (15.9 mm)	1 3/8" (34.9 mm) annular or 6d box nails**	

** Alternate: On walls, 1 1/4" (31.8 mm) Type W screws are spaced 12" (305 mm) when framing is 24" o.c. (610 mm) or 16" o.c. (406 mm).

TABLE 1—SPACING OF FRAMING OR FURRING

Type of Framing or Furring	Kal-Kore Thickness	Maximum Spacing on center
Wood	3/8" (9.5 mm)	*16" (406 mm)
	1/2" (12.7 mm)	**24" (610 mm)
	5/8" (15.9 mm)	24" (610 mm)
***Metal	3/8" (9.5 mm)	N.A.
	1/2" (12.7 mm)	16" (406 mm)
	5/8" (15.9 mm)	24" (610 mm)

N.A.—Not Approved.

* Bound edge of Kal-Kore must be at right angles to framing for ceiling or walls.

** Bound edge of Kal-Kore must be at right angles to joists. 16" (406 mm) maximum spacing for bound edge of Kal-Kore parallel to joists.

*** On ceilings, furring channel [7/8" (22.2 mm) depth] shall span 48" (1219 mm) maximum. Resilient furring channel [1/2" (12.7 mm) depth] shall span 24" (610 mm) maximum. For greater spans, 1 5/8" (41.3 mm) Steel Studs may be used as Ceiling Furring Channels provided they are secured with flanges up (open side up) at spans not to exceed: 6' (1829 mm) at 12" o.c. (305 mm) spacing, 5'6" (1676 mm) at 16" o.c. (406 mm) spacing and 5' (1524 mm) at 24" o.c. (610 mm) spacing.

Note: Veneer Plaster Systems are to be installed with maximum deflection criteria of L/240.



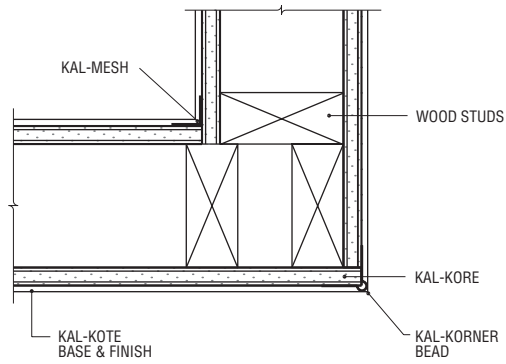

CORNER-WOOD STUDS

09215A
Scale: 2 1/4" = 1'-0"

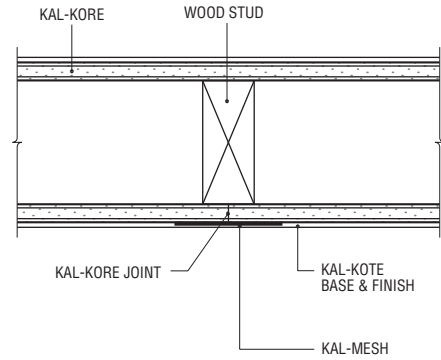

JOINT DETAIL

09215C
Scale: 2 1/4" = 1'-0"

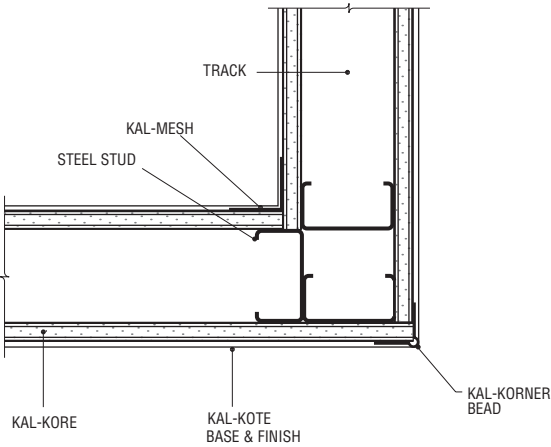

CORNER-STEEL STUDS

09215B
Scale: 2 1/4" = 1'-0"

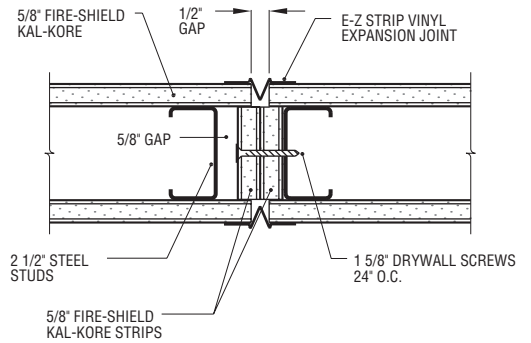

ONE HOUR FIRE RATED CONTROL JOINT DETAIL
Based on Warnock-Hersey Report No. WH-651-0318.1
and Factory Mutual Design No. W1B-1 hr.

09215D
Scale: 2 1/4" = 1'-0"

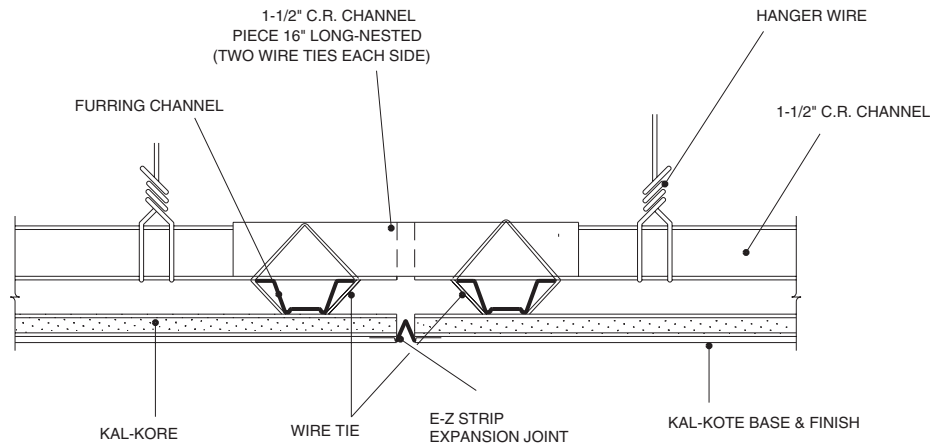

SUSPENDED VENEER PLASTER CONTROL JOINT

09215E

09 26 13

VENEER PLASTER FOR METAL AND WOOD FRAMING

1. Wood Studs or Joists.

Wood members shall meet the minimum requirements of local building codes. Framing shall not exceed spacing shown in Table 1 on page 46. Most partition fire ratings require that Kal-Kore be applied vertically. When such ratings are not required, horizontal application may be used to minimize joints. For ceilings, application at right angles to framing is preferred.

2. Metal Studs. Align floor and ceiling tracks to ensure plumb partition. Secure track with appropriate fasteners at a maximum of 24" o.c. Position studs in track on specified centers by rotating into place for a friction fit. Secure studs located adjacent to door and window frames, partition intersections and corners by self-drilling sheet metal screws through both flanges of studs and tracks or by use of steel stud clinching tool. Apply Kal-Kore vertically for most fire ratings. When ratings are not required, horizontal application may be used to minimize joints.

3. Masonry Wall Furring with Screw Furring Channel. Attach furring channel vertically spaced not to exceed spacing shown in Table 1 on page 44. Fasten

each channel with concrete stub nails or appropriate fasteners through channel flanges into the masonry or concrete. Fasteners shall be spaced on alternate flanges not over 24" o.c. Apply Kal-Kore vertically or horizontally in maximum lengths to minimize end joints.

4. Furred Ceilings with Bar Joists. Attach regular furring channel 16" o.c. to bar joists spaced up to 4' o.c. Resilient Furring Channel (wire-tied only) shall span a maximum of 24". Wire tie Furring Channel to joists or use 1 1/2" Drywall Furring Channel Clip for 1 1/2" carrying channel. Apply Kal-Kore with paper bound edges at right angles to the furring channel.

KAL-KORE AND HI-ABUSE® KAL-KORE APPLICATION

Note: Application shall conform to ASTM C 844.

1. Cut and position Kal-Kore accurately. Bring all joint edges together but do not force into place. Position all end joints over framing members. To avoid ridging, minimize gaps between adjacent boards.
2. Minimize the number of end joints by using maximum practical lengths with proper positioning.
3. Stagger joints so that they occur on different framing members and will not be directly opposite one another on partitions.

Avoid joining Kal-Kore at corners of doors, window frames, and other openings, unless control joints are created using E-Z Strip Control Joints.

4. Fasten Kal-Kore to framing members with face out, using the proper type and spacing of fasteners shown under types of fasteners.
5. Draw Kal-Kore tight to framing. Drive fasteners straight and dimple the surface without breaking the paper face.

KAL-KORNER BEAD APPLICATION

Install Kal-Korner Bead using appropriate fasteners spaced 12" apart.

E-Z STRIP CONTROL JOINT APPLICATION

Install E-Z Strip Control Joint at 30' max. spacing on walls and 50' max. spacing in either direction on ceilings. Apply the control joint with staples spaced 6" along each side of the flanges.

TREATMENT OF KAL-KORE JOINTS

Pre-treat all joints and fasteners in Kal-Kote and Uni-Kal Plaster Systems with Kal-Kote Base Plaster, Uni-Kal, X-KALibur or Sta-Smooth Joint Compound.

Low humidity, high temperatures and rapidly circulating air can cause cracking of plaster and joint beading when Kal-Kore is

applied to metal framing. To minimize this during these conditions, joints may be pre-treated using paper tape.

Three acceptable methods of treating Kal-Kore joints are:

DRYWALL PAPER TAPE TREATMENT METHOD

1. Trowel Kal-Kote Base Plaster, Uni-Kal or X-KALibur over joint line filling the channel formed by the tapered edges of the Kal-Kore board in an even fashion.
2. Center drywall paper tape over the joint line and embed the tape into the soft plaster using a trowel and level the joint. Tape the full length of the joint.
3. Allow the treated joints to set *prior* to general plaster application.



STA-SMOOTH PAPER TAPE TREATMENT METHOD

1. Mix Sta-Smooth Compound per instructions on package. Do not contaminate the compound with other materials, dirty water or previous mixes. Do not retemper.
2. Apply the Sta-Smooth Compound to the joint by hand or machine tool. The drywall paper tape must be centered over the joint line and embedded into the soft compound. Do not over-trowel to a slick surface. Leave the surface rough to provide mechanical keying of the plaster.
3. Allow the treated joints to set and dry *prior* to general plastering.

KAL-MESH TREATMENT METHOD

Do not use self-adhering mesh.

1. Center and secure Kal-Mesh over all joints and interior angles with 1/4" or 5/16" staples.
2. Position staples a maximum of 24" apart as follows:
 - A. Joints: at alternate edges for the run from end to end and directly opposite one another at either end.
 - B. Angles: along ceiling edge only for wall-to-ceiling angles. Along one edge for wall-to-wall angles.
3. After the first staples are placed at the end of a joint or angle, pull unstapled Kal-Mesh as stapling proceeds to ensure that it will lie flat against the Kal-Kore.
4. Pre-treat all joints and Kal-Beads with Kal-Kote, Uni-Kal or X-KALibur Plaster. Tightly trowel over joint line in both directions to prevent voids, feathering to a maximum width of about 6".
5. Allow the treated joints to set *prior* to general plaster application.

PLASTERING

Note: Application shall conform to ASTM C 843.

The same general job conditions used in good conventional plastering practice should be maintained. However, because Veneer Plaster coats are thin, particular action must be taken to

guard against dryouts (primarily avoiding direct exposure to concentrated sources of heat and drafts.)

Special attention should also be given to temperature conditions under which the system is installed. Both "in-place" and application performance of individual Veneer System components will be greatly enhanced if all construction areas and materials are at a suitable temperature equilibrium before, during and after installations. During cold weather, maintain a temperature 55°F (13°C) to 70°F (21°C) before, during and after installation of all system components until veneer plaster has dried.

MIXING

Equipment: Mixing should be done with a high-speed mechanical mixer. A paddle-type agitator fitted to a 500-600 RPM heavy duty, 1/2" electric drill and a clean, smooth-sided drum of convenient size are recommended for rapid, efficient mixing of all Kal-Kote Plaster types.

Water Ratios: Use only clean, fresh water suitable for human consumption.
 Basecoat: 10-12 qts. per 80 lb. bag. Smooth Finish: 18-20 qts. per 50 lb. bag.
 Texture Finish: 11-12 qts. per 50 lb. bag. Uni-Kal and X-KALibur: 13-15 qts. per 50 lb. bag.

PROCEDURE

1. Put all but 1 to 2 qts. of the proper water volume in a suitable mixing drum.

Note: Starting with an insufficient amount of mixing water will seriously degrade mixing and application performance.

2. Add plaster and allow to soak for about 1 minute or add plaster as mixer is turning, then mix until uniformly wetted.
3. Add remaining water and mix sufficiently to obtain desired lump-free material fluidity.

Note:

- A. Mixing periods greater than 5 minutes will not be required if proper equipment and procedure are used.
- B. Mix no more than two bags per batch to avoid mixing too far in advance of application.



- C. Caution is advised against mixing more than two successive batches without thorough equipment clean-up to avoid undue set acceleration.
- D. Avoid the practice of mixing partial bags since this leads to difficulty in maintaining uniform material qualities.

JOB SETTING ADJUSTMENT

1. Basecoat and Finish Plasters: Small amounts of commercial retarder or commercial gypsum type accelerator may be cautiously used to adjust setting time when extreme conditions demand. When commercial retarder or accelerator is used, add to mixing water directly, or in previously prepared water solution form to obtain the most uniform effect.
2. Never use gauging or moulding plasters in place of commercial accelerator since they can adversely affect working qualities.

KAL-KOTE APPLICATION OVER KAL-KORE

Basecoat Over Kal-Kore

1. Tightly scratch material into previously treated joints and cornerbeads, then immediately scratch-in tightly over the wall and/or ceiling area.
2. Double back over the area just troweled with material from the same batch, bringing total thickness up to 1/16" minimum.
3. When plaster has "taken up," eliminate excessive trowel marks and fill all surface voids and imperfections to obtain a reasonably uniform surface. Do not over-trowel to a slick surface. Roughen the unset basecoat plaster surface with a serrated darby or lightly wire rake to provide mechanical keying

for the finish plaster when necessary.

Smooth Finish Over Basecoat

1. Apply only over properly prepared Kal-Kote basecoat plaster. Scratch-in tightly, then double back with material from the same batch immediately to create a uniform coat not exceeding 1/16" in average thickness.

2. Remove trowel marks, "cat faces," and other major surface imperfections by "drawing-up" or "laying down" the surface with light trowel pressure when plaster has stiffened.

Use water sparingly if needed, but do not over-trowel or over-water because this aggravates any normal tendency for blistering when working over low suction bases. Such blistering will be eliminated by the final water-troweling operations.

3. Water-trowel to densify and polish the surface to the desired degree when plaster has set, eliminating any blistering if present. Never use a felt "blister brush" as a substitute for water troweling!
4. Uni-Kal and X-KALibur Plaster may be substituted for Kal-Kote Smooth Finish.

Texture Finish Over Basecoat

1. Apply per (1) under Smooth Finish.
2. When plaster has stiffened, float its surface to any desired finish.

Do not float the soft surface of plaster which has already set.

Up to equal parts by weight of clean, graded silica sand may be added to Uni-Kal and X-KALibur to aid texturing.



UNI-KAL OR X-KALIBUR APPLICATION OVER KAL-KOTE

1. Tightly scratch material into previously treated joints and cornerbeads, then immediately scratch-in tightly over the wall and/or ceiling area.
2. Double back over the area just troweled with material from the same batch bringing total thickness up to 3/32" minimum.
3. Begin finish troweling at time of initial set, using water sparingly. Final troweling must be accomplished before complete set takes place, as evidenced by darkening of the surface.

Note: Uni-Kal or X-KALibur may be applied to produce a textured finish.

- A. When Uni-Kal or X-KALibur is mixed, add up to but not exceeding 50 lbs. of silica sand, texturing grade, per 50 lb. bag of plaster.
- B. The sanded Uni-Kal or X-KALibur mix should be scratched-in tightly over the plastering base. Immediately double back over the area just troweled with material from the same batch.
- C. When plaster is well taken up, float to the desired texture finish.

VENEER PLASTERS DIRECT TO BOND-COATED MONOLITHIC CONCRETE

DESCRIPTION

The Kal-Kote System, consisting of a basecoat plaster and a finish coat plaster, Uni-Kal or X-KALibur may be applied directly to monolithic concrete treated with a bonding agent.

LIMITATIONS

1. Surface to be plastered shall be treated with a bonding agent applied according to manufacturer's directions. The performance of this system is the sole responsibility of the bonding agent manufacturer.
2. Concrete should be aged at least one month prior to plastering.
3. Kal-Kote Smooth or Texture Finishes are not designed for direct application to concrete, but must first have Kal-Kote Base Plaster applied to fill and level surface.
4. Do not apply system to the interior side of exterior walls below grade. To use above grade these walls shall be kept dry and shall have been properly waterproofed on the exterior side to prevent water penetration.

APPLICATION PROCEDURES

Note: Application shall conform to ASTM C 843.

Kal-Kote Base Application Over Bonding Agent

1. First straighten any major surface irregularities, such as holes, ridges, wavy sections, etc. Scratch plaster in tightly by trowel and fill out to any adjacent level area.
2. After the straightening material has set, trowel in a tight scratch coat over the entire area to be plastered; then immediately double back with material from the same batch to minimum thickness of 1/16" or as required to achieve a level surface. Use a rod or feather edge if needed.
3. When plaster has "taken up," eliminate excessive trowel marks and fill all surface voids and imperfections to obtain a reasonably uniform surface. Do not trowel to a slick surface. Roughen the unset basecoat plaster surface with a serrated darby or lightly wire rake to provide mechanical keying for the finish plaster when necessary.

Smooth or Textured Finishes

Apply finishes to the Kal-Kote Plaster as outlined under the regular Kal-Kote System as described on page 49.

Uni-Kal or X-KALibur Application Over Bonding Agent

1. First straighten any major surface irregularities such as holes, ridges, wavy sections, etc. Scratch plaster in tightly by trowel and fill out to any adjacent level area.
2. Allow the straightening material to set.
3. Tightly scratch material in over the wall and/or ceiling area. This application should be about 1/16" thick. Double back over the area just troweled with material from the same batch, bringing total thickness up to 3/32" minimum.
4. Begin finish troweling at time of initial set, using water sparingly. Final troweling must be accomplished before complete set takes place, as evidenced by darkening of the surface.



Veneer plaster performs well in high traffic areas such as stairways and halls.



Veneer plaster walls are particularly suited to accommodate wall situations where light conditions require smooth, even expanses of wall.



The Veneer plaster wall system is particularly suited to residential and commercial construction in areas which need strength for special architectural details, and unusual design elements.

VENEER PLASTERS DIRECT TO UNIT MASONRY

DESCRIPTION

The Kal-Kote System, consisting of a basecoat plaster and a finish coat plaster, Uni-Kal or X-KALibur, the one-coat system, may be applied directly to masonry surfaces providing the following recommendations are followed.

RECOMMENDATIONS

1. Surface must be free from dirt, grease, oil, mold, parting agents, or any material which will prevent plaster adhesion.
2. When erecting masonry, strike joints flush. If masonry has recessed joints, fill joints flush to masonry surface with basecoat plaster, Uni-Kal or X-KALibur and allow to set.

EXTERIOR CORNERS

Install cornerbead with adhesive at least 4 and preferably 16 hours before plastering. Apply a continuous bead of adhesive approximately 1/4" x 1/4" along the inside of both cornerbead flanges. Press the bead firmly over the corner so that adhesive is in continuous contact with masonry surface. Align bead and allow to stand undisturbed at least 4 hours.

KAL-KOTE APPLICATION

Note: Application shall conform to ASTM C 843.

Proceed with the full field of the wall by scratching-in tightly, then double back immediately with material from the same batch to a minimum thickness of 1/16" over the block surface, or as required to level.

Kal-Kote Finishes should be kept as thin as possible and applied as described on page 44 and 51.

UNI-KAL OR X-KALIBUR APPLICATION

Proceed with full field of the wall by scratching-in tightly, then double back immediately with same batch of material to a minimum thickness of 3/32" over the block surface.

Caution: Since Uni-Kal or X-KALibur is a one-coat material system, exercise care in leveling the wall to compensate for the uneven suction.

VENEER SYSTEMS APPLIED TO MASONRY WITH Z FURRING CHANNEL SYSTEM

DESCRIPTION

This system consists of a Z Furring Channel, rigid insulation and the components of the Kal-Kote

and Uni-Kal or X-KALibur Veneer Plaster Systems. The Z Furring Channel is manufactured from galvanized steel (.0179" min. base steel) and is produced with web depths of 1", 1 1/2" and 2". The furring channel which is applied to a masonry wall holds the insulation in place and the wide flange serves as framing for the application of the Kal-Kote plastering base.

LIMITATIONS

1. Since the interior wall surface will take the general configuration of the masonry wall, it may be necessary when applying the system to unit masonry to use portland cement plaster to bring the wall to a plane surface.
2. This system is mainly for new masonry construction. On well-cured concrete or masonry, it may be difficult to properly drive fasteners.
3. Power-driven fasteners shall be used only for attachment to monolithic concrete surfaces.
4. Kal-Kote should be applied within 24 hours of foam application.



Design flexibility is achieved with veneer plaster systems.

APPLICATION PROCEDURES

1. Begin application of Z Furring members by positioning first channel vertically at a corner, locating it on the wall adjacent to the wall being insulated first.

The insulation thickness determines the distance of Z Furring web from wall being insulated. At the appropriate distance, with wide flange pointing toward applicator, secure Z Channel with appropriate fasteners, spaced 24" o.c. driven through short flange. (Note: Power-driven fasteners are not recommended for use with masonry block.)

Install 24" wide floor-to-ceiling insulation board, pressed snugly against web of first Z. Install next Z with the wide flange overlapping the edge of the first insulation board. Fasten Z to wall through narrow flange. Continue in this manner with Z Furring member 24" o.c. to end of wall. Locate last Z so that web is located a distance equal to insulation thickness from adjoining wall. Cut last insulation board to fit remaining space.

At exterior corner, attach the Z through its wide flange with narrow flange extending beyond the corner. Begin with a narrow strip of floor-

to-ceiling insulation, wider than insulation thickness, but not exceeding 3". Continue application of furring and insulation progressively as described above.

At windows, doors and trim areas, use wood nailers, nominal 2" wide x insulation thickness plus 1/32". Use the nailers also at wall-floor angles to support trim and provide backing for base.

2. Apply Kal-Kore to the flanges of Z Channel with 1" Type S screws spaced 12" o.c. Normally, vertical application of Kal-Kore is recommended; however, for installations 8' or less in height, horizontal application may be preferred since the number of joints would be reduced.
3. Apply Kal-Mesh and Kal-Korner Bead according to procedures described on page 50 and 51.
4. Mix and trowel on Kal-Kote Base and Finish Plaster or Uni-Kal Plaster as described on pages 46, 51 and 52.

PAINTING PLASTER

Various job conditions such as suction differences, wet or only partially dry walls, and reactions between paint and lime may cause unsatisfactory paint finishes, particularly on new construction.

Alkali-resistant primers specifically formulated for use over new plaster will permit decorating with oil or latex type paints. Quality paint products should be used and manufacturers' recommendations followed. Finished plaster should be painted or covered to conceal possible discoloration. The paint system should be suitable for use over plaster surfaces that contain lime, which has a high pH of 10-13.

It is essential that plaster be sound and completely dry before painting. Under good drying conditions, veneer plaster may be painted 48 hours after application.

High build, heavy duty and special purpose coatings such as Epoxy are not recommended over veneer or job gauged lime putty finishes.

In all cases, the paint manufacturer should be consulted and approve paint system suitability for use with gypsum/lime finish plaster.

STORAGE

Gypsum plaster must be kept dry before use. Storage conditions vary with location and seasonal changes, which may affect storage life. These conditions may affect product characteristics such as setting time, working qualities, component separation, or lumping, etc. Such aging is normally a function of exposure to humid air, temperature, and physical support in warehousing. Adverse storage conditions or prolonged storage may affect the working qualities of the product. Rotate inventory frequently for best results.

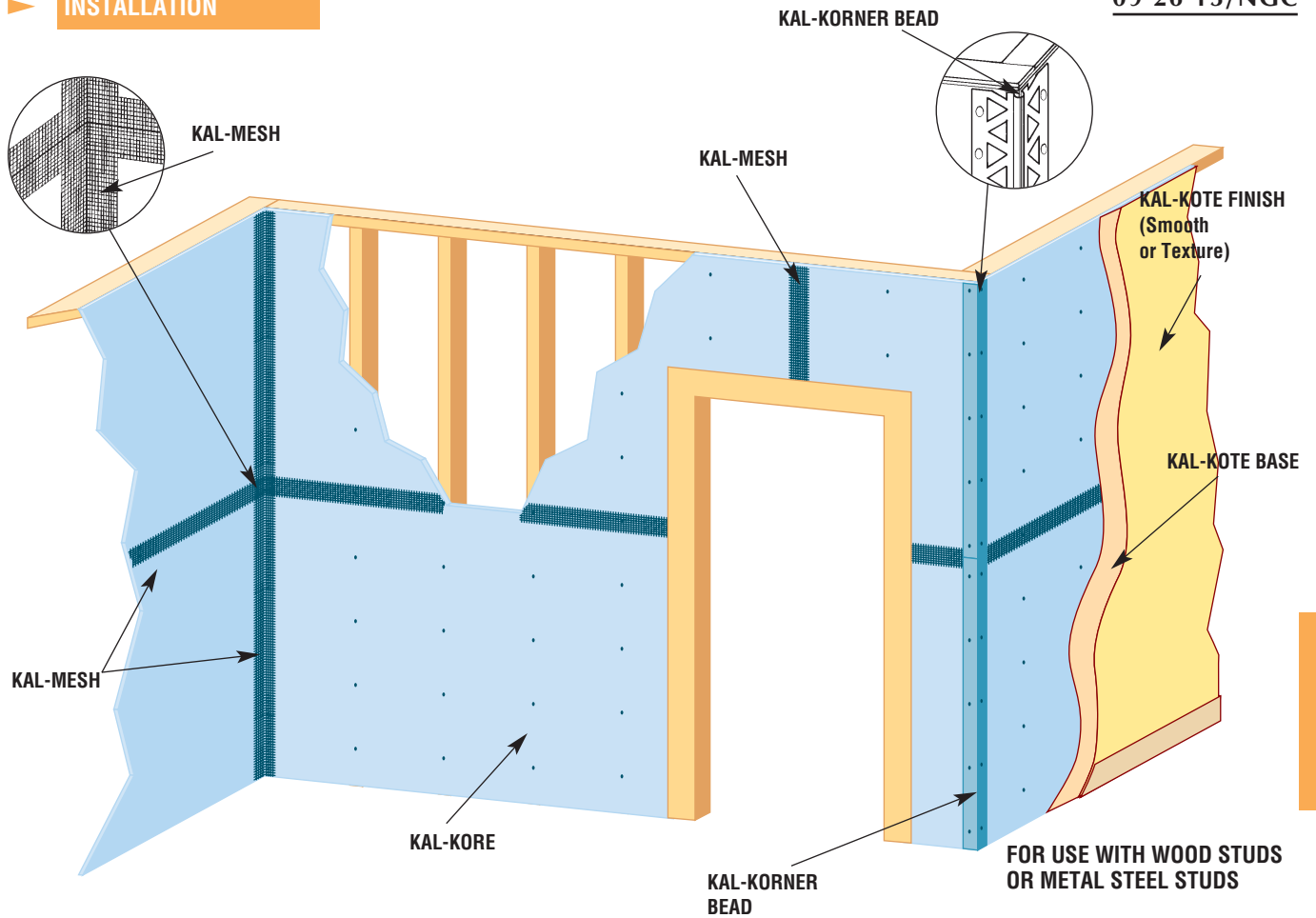

09 26 13

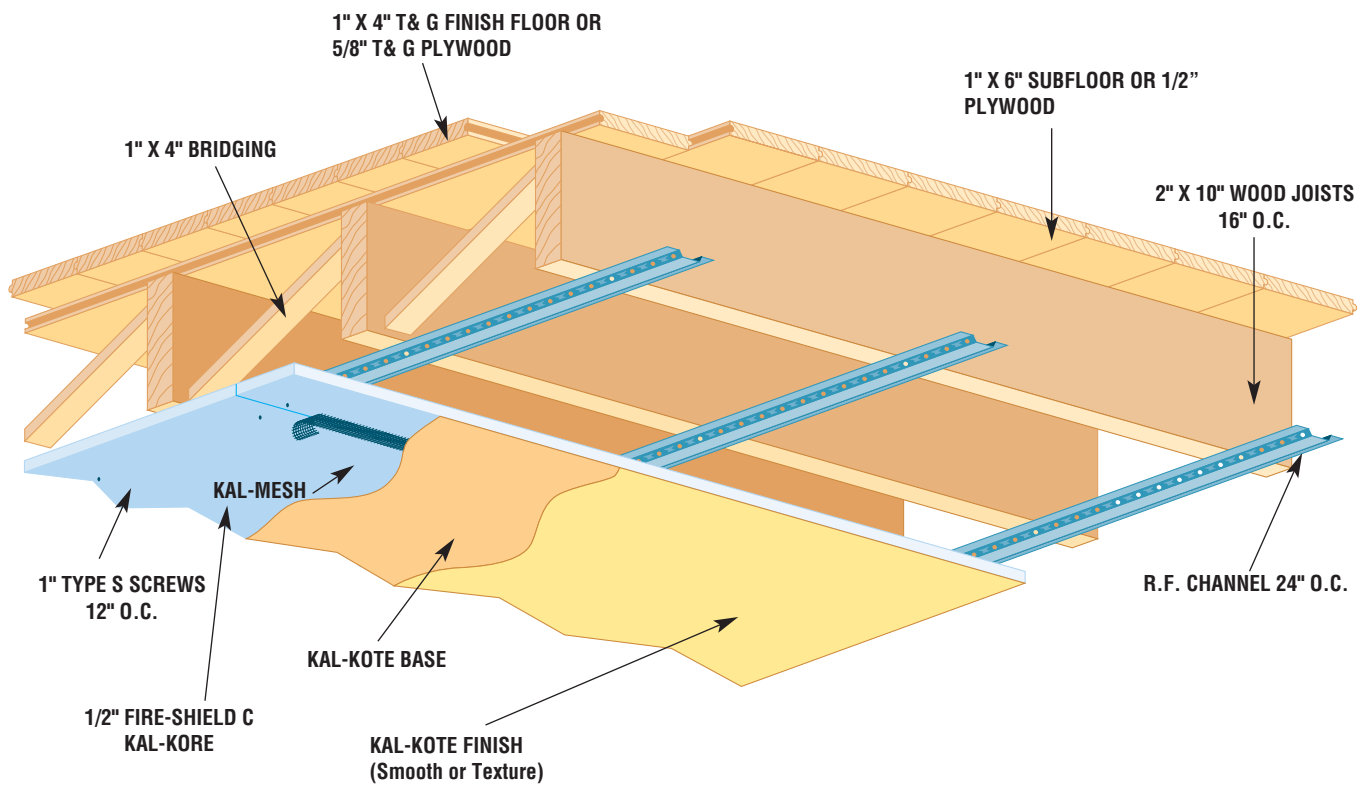

U.L. DESIGN L515

SECTION 09 26 13

VENEER PLASTER

THE FOLLOWING PARAGRAPHS ARE FOR INSERTION INTO SECTIONS OF GENERIC SPECIFICATIONS OR GENERIC/PROPRIETARY SPECIFICATIONS COVERING VENEER PLASTER PRODUCTS. THE NATIONAL GYPSUM COMPANY PRODUCT NAME FOLLOWS THE GENERIC DESCRIPTION IN PARENTHESES.

PART 1 GENERAL

1.02 REFERENCES

- A. American Society for Testing and Materials (ASTM):
 1. C 587, Specification for Gypsum Veneer Plaster.
 2. C 1396, Specification for Gypsum Board (Gypsum Base for Veneer Plaster).
 3. C 843, Specification for Application of Gypsum Veneer Plaster.
 4. C 844, Specification for Application of Gypsum Base to Receive Gypsum Veneer Plaster.

PART 2 PRODUCTS

2.01 MANUFACTURER

- A. National Gypsum Company

2.02 MATERIALS

A. Veneer Plaster Base:

1. Regular: A gypsum core lathing board surfaced with absorptive paper on front, and long edges and complying with ASTM C 1396 (Gold Bond BRAND Kal-Kore Plaster Base).
 - a. Thickness: 3/8" or 1/2"
 - b. Width: 4'
 - c. Length: 8' through 16'
 - d. Edges: Tapered
2. Fire-Resistant: A gypsum core lathing board with additives to enhance the fire resistance of the core and surfaced with absorptive paper on front, and long edges and complying with ASTM C 1396, Type X.
 - a. Thickness: 1/2" (Gold Bond BRAND Kal-Kore Fire-Shield C Plaster Base) or 5/8" (Gold Bond BRAND Kal-Kore Fire-Shield and Fire Shield C Plaster Base).
 - b. Width: 4'
 - c. Length: 8' through 16'
 - d. Edges: Tapered
3. Regular, Foil-Backed: A gypsum core lathing board surfaced with absorptive paper on front, and long edges; backed with aluminum foil; and complying with ASTM C 1396 (Gold Bond BRAND Kal-Kore Foil-Back Plaster Base).
 - a. Thickness: 1/2"
 - b. Width: 4'
 - c. Length: 8' through 16'
 - d. Edges: Tapered
4. Regular, Abuse-Resistance: A gypsum core lathing board with additives to enhance impact resistance and surfaced with absorptive paper on front and long edges with heavy liner paper bonded to the back side; and complying with ASTM C 1396 (Gold Bond BRAND Hi-Abuse Kal-Kore Plaster Base).
 - a. Thickness: 1/2"
 - b. Width: 4'
 - c. Length: 8' through 12'
 - d. Edges: Tapered

5. Fire Resistant, Abuse Resistant: A gypsum core lathing board with additives to enhance fire and impact resistance and surfaced with absorptive paper on front and long edges with heavy liner paper bonded to the back side; and complying with ASTM C 1396, Type X (Hi-Abuse BRAND Kal-Kore Fire-Shield Plaster Base).

- a. Thickness: 5/8"
- b. Width: 4'
- c. Length: 8' through 12'
- d. Edges: Tapered

B. Gypsum Plaster:

1. Base Plaster: High strength gypsum plaster complying with ASTM C 587 (Kal-Kote BRAND Base Coat Plaster).
2. Finish Plaster: Gypsum plaster for smooth finish complying with ASTM C 587 (Kal-Kote BRAND Smooth Finish Plaster).
3. Finish Plaster: Gypsum plaster for textured finish complying with ASTM C 587 (Kal-Kote BRAND Texture Finish Plaster).

IF TEXTURED FINISH IS SPECIFIED FOR BELOW, SAND MAY BE REQUIRED.

4. One Coat Plaster: Gypsum plaster for single component application complying with ASTM C 587 (Uni-Kal BRAND Veneer Plaster).
5. One Coat Plaster: Extended set gypsum plaster for single component application complying with ASTM C 587 (X-KALibur BRAND Veneer Plaster).

PART 3 EXECUTION

3.01 INSTALLATION

- A. In accordance with the manufacturer's recommendations, National Gypsum Company "Gypsum Construction Guide," and the following standards:
 1. Gypsum plaster base and accessories in accordance with ASTM C 844.
 2. Gypsum veneer plaster in accordance with ASTM C 843.
- B. Tolerances: For flatness of surface, do not exceed 1/4" in 8' for bow or warp of surface and for plumb and level.

Gypsum Board Systems



09 29 00

National 
Gypsum®

Gold Bond® BRAND Gypsum Board Products

National Gypsum Company features a wide variety of gypsum board products and accessories including regular gypsum board, Fire-Shield fire resistant board, 1/4" High Flex Gypsum Board, 1/2" High Strength Ceiling Gypsum Board, Hi-Impact Gypsum Board, Gridstone Ceiling Boards, Gypsum Sheathing, Fire-Shield Shaftliner, Durasan Prefinished Gypsum Board, Exterior Soffit Board, and Joint Treatment products.

Our concentration isn't on building products alone, however. At the National Gypsum Research and Testing Center, we develop complete construction systems. In such systems, products are evaluated together as complete building assemblies—walls, partitions, floors and ceilings.

We have included in this section details and application instructions for many of those assemblies: Steel Frame Partitions, Steel Frame Ceilings/Furring Channels or Studs, Wood

Frame Wall and Ceilings, Gypsum Board Over Foam Insulated Masonry and Solid Laminated Partitions.

Before a National Gypsum System is released to the building industry, it is thoroughly tested, and results are correlated and charted to make it easier for the builder or specifier to match a system to their needs or to the building codes.

The drywall construction systems referred to in this catalog are designed primarily with materials manufactured by National Gypsum

Company. Substitution of any product or other brands in a tested system is not recommended.

Field installation of tested systems must be identical to laboratory installation to produce optimum performance of these systems. Performance tests are conducted in accordance with accepted national standards under controlled laboratory conditions to minimize variances and to permit comparison of test results with all types of systems, similar and dissimilar.

DESCRIPTION

Description

Core Thickness/Type Width/Edge Lengths

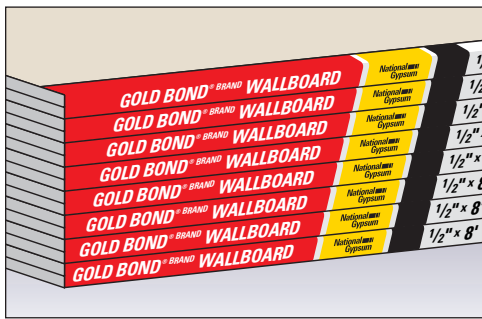

Gold Bond BRAND Gypsum Board with tapered edge permits smooth joint treatment; surface takes any decoration. Basic recommendations: 1/2" board for single layer; 3/8" board for 2-layer; 1/4" board is regular gypsum board used in remodeling and for sound control in double layer applications. Refer to page 65.

Regular	1/4" (6.3 mm)	4' (1219 mm)	6' (1828 mm) thru 16' (4876 mm)
	3/8" (9.5 mm)		
	1/2" (12.7 mm)*		
		Square or Tapered	

Note: 1/2" gypsum board available in 54" widths.

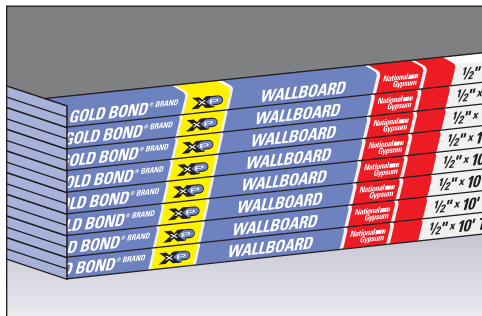

Gold Bond BRAND XP Gypsum Board is designed to provide extra protection against mold and mildew compared to standard gypsum board products. Tapered edge permits smooth joint treatment. Refer to page 70.

Regular	1/2" (12.7 mm)	4' (1219 mm)	8' (2438 mm)
			10' (3048 mm)
			12' (3657 mm)
		Square or Tapered	



Gold Bond BRAND Fire-Shield Gypsum Board is manufactured with a type X core to achieve fire resistance ratings when used in recommended systems. Refer to page 66.

Gold Bond BRAND Fire-Shield C Gypsum Board has a specially formulated type X core to achieve superior performance when used in specific fire rated assemblies. May be used in designs requiring Fire-Shield Gypsum Board (type X core). Refer to page 66.

Type X	5/8" (15.9 mm) FSW*	4' (1219 mm)	6' (1828 mm) thru 16' (4876 mm)
		Square or Tapered	

Type X	1/2" (12.7 mm) FSW-C	4' (1219 mm)	6' (1828 mm) thru 16' (4876 mm)
		Square or Tapered	

Type X	5/8" (15.9 mm) FSW-C	4' (1219 mm)	8' (2438 mm) thru 14' (4267 mm)
		Square or Tapered	

Note: 5/8" Fire-Shield gypsum board available in 54" widths.

* Available with Foil Backing. Refer to page 86.

Reference www.nationalgypsum.com for fire safety information.

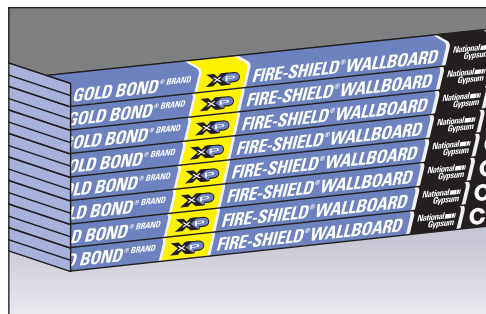

Description

Core Thickness/Type Width/Edge Lengths

Gold Bond BRAND XP Fire-Shield Gypsum Board is manufactured with a fire resistive type X gypsum core and is designed to provide extra protection against mold and mildew. Refer to page 70.

Gold Bond BRAND XP Fire-Shield C Gypsum Board has a specially formulated type X gypsum core to achieve superior fire resistance performance and is designed to provide extra protection against mold and mildew. Refer to page 70.

Type X 5/8" (15.9 mm) FSW-3	4' (1219 mm)	8' (2438 mm) thru 12' (3657 mm)
	Square or Tapered	
Type X 1/2" (12.7 mm) FSMR-C	4' (1219 mm)	8' (2438 mm) thru 12' (3657 mm)
	Square or Tapered	
Type X 5/8" (15.9 mm) FSMR-C	4' (1219 mm)	4' (1219 mm) thru 12' (3657 mm)
	Square or Tapered	

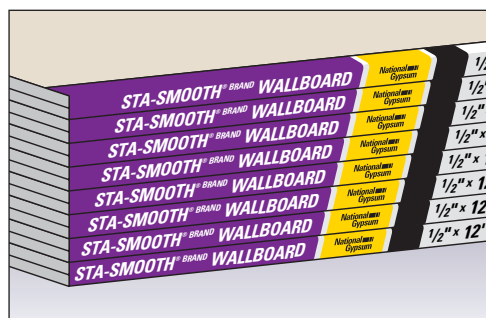

Gold Bold BRAND Sta-Smooth Gypsum Board, used with ProForm BRAND Sta-Smooth Joint Compound, forms a drywall system offering maximum joint strength. Two edge configurations provide relief on joint deformities. The round edge configuration solves joint deformity problems caused by twisted framing, damaged board edges, poor alignment and extremes in humidity and temperature. Refer to page 67.

Regular 1/2" (12.7 mm)	4' (1219 mm)	6' (1828 mm) thru 16' (4876 mm)
	Sta-Smooth	
Type X 5/8" (15.9 mm) FSW	4' (1219 mm)	8' (2438 mm) thru 16' (4876 mm)
	Sta-Smooth	
Type X 1/2" (12.7 mm) FSW-C	4' (1219 mm)	6' (1828 mm) thru 16' (4876 mm)
	Sta-Smooth	

Note: 1/2" regular Sta-Smooth gypsum board available in 54" widths.



Gold Bond BRAND Kal-Kore Plaster Base is a tapered edge gypsum board plastering base having a blue absorptive face paper surface designed to permit rapid trowel application and strong bond of veneer or conventional gypsum plaster. Refer to page 45.

Regular 3/8" (9.5 mm) or 1/2" (12.7 mm)	4' (1219 mm)	8' (2438 mm) thru 16' (4876 mm)
	Square or Tapered	
Type X 1/2" (12.7 mm) FSK-C or 5/8" (15.9 mm) FSK	4' (1219 mm)	8' (2438 mm) thru 16' (4876 mm)
	Square or Tapered	

Note: 1/2" regular Kal-Kore plaster base available in 54" widths.

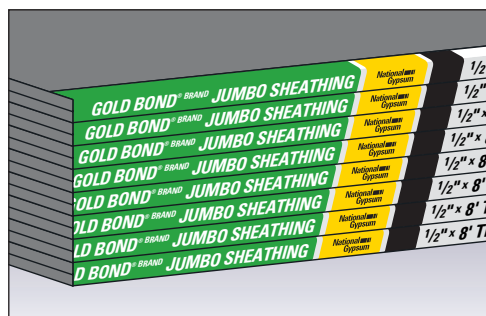

Gold Bond BRAND Gypsum Sheathing is used as an underlayment on exterior walls. Finish materials are applied with fasteners through sheathing into studs or furring strips. Refer to page 28.

Regular 1/2" (12.7 mm)	4' (1219 mm)	8' (2438 mm) thru 10' (3048 mm)
	Square	
Type X 5/8" (15.9 mm) FSW-3	4' (1219 mm)	8' (2438 mm) thru 10' (3048 mm)
	Square	

09 29 00

Description

Core Thickness/Type Width/Edge Lengths

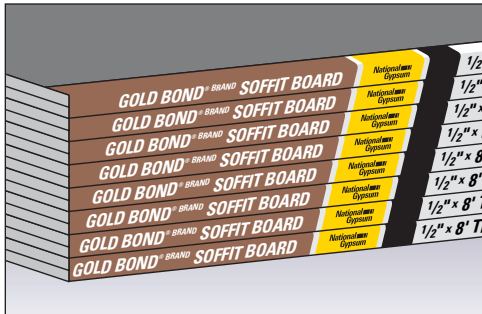

Gold Bond BRAND Exterior Soffit Board is designed to provide, in a fire resistive gypsum ceiling board, the extra resistance to moisture and sagging required to meet protected outdoor conditions. Refer to page 71.

Regular	1/2" (12.7 mm)	4' (1219 mm) Sta-Smooth	8' (2438 mm) thru 12' (3658 mm)
Type X	5/8" (15.9 mm) FSW	4' (1219 mm) Sta-Smooth	8' (2438 mm) thru 12' (3658 mm)

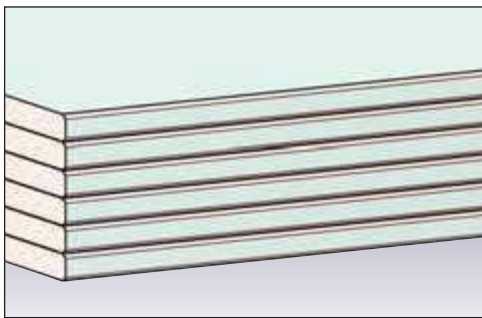

Gold Bond BRAND Fire-Shield Shaftliner is used as a component in shaftwall systems, in area separation walls and in solid gypsum partitions. The product has moisture resistant green paper on both faces. Refer to pages 73, 110, 124 and 140.

Type X	1" (25.4 mm) FSW	2' (610 mm) Beveled Edges	Custom Cut thru 7' (2134 mm) thru 14' (4267 mm)
--------	------------------	---------------------------	---

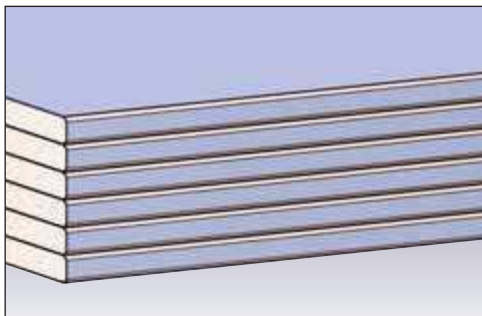

Gold Bond BRAND Fire-Shield Shaftliner XP is used as a component in shaftwall systems, area separation walls and solid laminated gypsum partitions. The product has moisture/mold/mildew resistant purple paper on both faces. Refer to page 74, 110, 124, and 140.

Type X	1" (25.4 mm) FSW	2' (610 mm) Beveled Edges	Custom Cut thru 7' (2134 mm) thru 14' (4267 mm)
--------	------------------	---------------------------	---

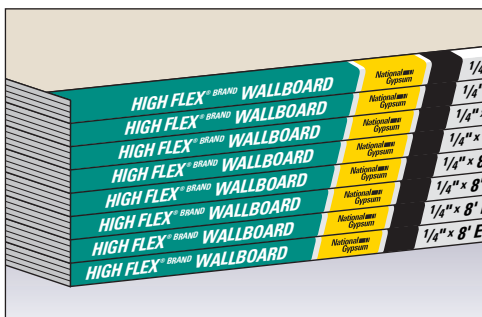

Gold Bond BRAND High Flex Gypsum Board is specifically designed for radius construction such as curved walls, archways and stairways. It can be used for both concave and convex surfaces. 1/4" High Flex is typically applied in double layers. Refer to page 75.

Regular	1/4" (6.3 mm)	4' (1219 mm) Eased	8' (2438 mm) thru 10' (3048 mm)
---------	---------------	--------------------	---------------------------------

Description	Core	Thickness/Type	Width/Edge	Lengths
 <p>Gold Bond BRAND High Strength Ceiling Gypsum Board is designed to resist sagging equal to 5/8" gypsum board. Installed perpendicular to framing, span can be up to 24" o.c. Can be decorated with spray textures and will support insulation. Refer to page 77.</p>	Regular	1/2" (12.7 mm)	4' (1219 mm) Tapered	6' (1828 mm)
				thru
				16' (4876 mm)
				1/2" x 12'
				1/2" x 12'
				1/2" x 12'

 <p>Gold Bond BRAND Hi-Abuse XP Fire-Shield Gypsum Board is designed for use in areas where surface durability and indentation resistance are major concerns. The product is manufactured with a mold and fire resistive Type X gypsum core encased in heavy smooth abrasion resistant, mold/mildew resistant purple paper on the face side and heavy mold/mildew resistant liner paper on the back side. Refer to page 78.</p>	Regular	5/8" (15.9 mm) FSW	4' (1219 mm) Square or Tapered	8' (2438 mm)
				thru
				12' (3657 mm)
				5/8" x 12'
				5/8" x 12'
				5/8" x 12'

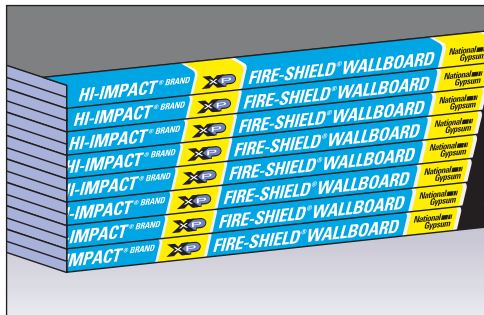
 <p>Gold Bond BRAND Hi-Impact XP Fire-Shield Gypsum Board is designed for use in areas where impact/penetration resistance is a major concern. The product is manufactured with a mold, moisture and fire resistant Type X gypsum core encased in heavy smooth abrasion resistant, moisture, mold/mildew resistant purple paper on the face side and heavy mold/mildew resistant liner paper on the back side. A fiberglass mesh is embedded in the board to provide additional impact/penetration resistance. Refer to page 81.</p>	Type X	5/8" (15.9 mm) FSW-5	4' (1219 mm) Tapered	8' (2438 mm)
				thru
				12' (3657 mm)
				5/8" x 12'
				5/8" x 12'
				5/8" x 12'

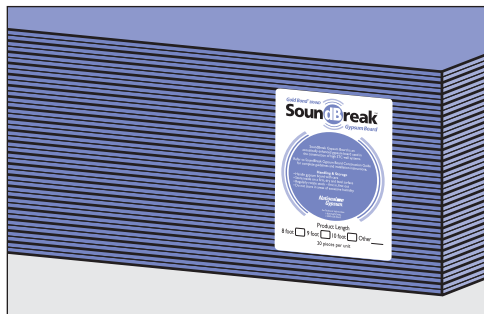
 <p>Gold Bond BRAND Soundbreak Gypsum Board is an acoustically enhanced gypsum board used in the construction of high rated STC wall assemblies. This 5/8" thick gypsum board consists of a layer of viscoelastic damping polymer sandwiched between two pieces of enhanced high density mold resistant gypsum board, providing constrained layer damping. Refer to page 84.</p>	Regular	5/8" (15.9 mm)	4' (1219 mm) Tapered	8' (2438 mm)
				thru
				12' (3658 mm)
				5/8" x 12'
				5/8" x 12'
				5/8" x 12'

09 29 00

Description

Core Thickness/Type Width/Edge Lengths

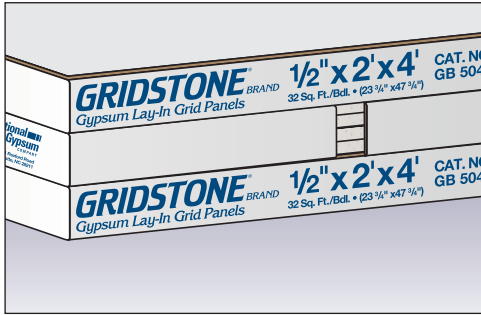

Gridstone BRAND Ceiling Panels have a fire resistant Fire-Shield G, type X core with a 2-mil textured vinyl laminate surface suited for interior or exterior application in exposed grid systems. Refer to page 86.

Type X 1/2" (12.7 mm) FSW-G 2' (610 mm) 2' (610 mm)
2' (610 mm) 4' (1219 mm)
Square

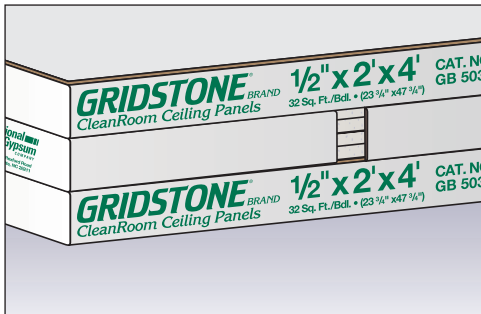

Gridstone BRAND CleanRoom Panels are designed for areas requiring high levels of air cleanliness for airborne particulate. Boards are sealed on face, back and long edges with a 2-mil rigid vinyl film and exposed edges are factory sealed with durable coating providing a completely sealed panel. Refer to page 87.

Type X 1/2" (12.7 mm) FSW-G 2' (610 mm) 2' (610 mm)
2' (610 mm) 4' (1219 mm)
Square

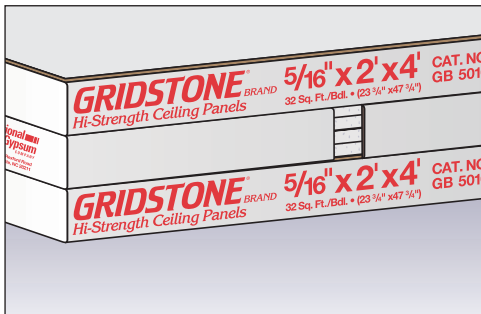

Gridstone BRAND Hi-Strength Ceiling Panels have a non-combustible high strength sag resistant gypsum core with a 2-mil textured vinyl laminate surface suited for interior or exterior application in exposed grid systems. Refer to page 88.

Regular 5/16" (7.9 mm) 2' (610 mm) 2' (610 mm)
2' (610 mm) 4' (1219 mm)
Square

METRIC CAPABILITIES

The Federal Government has mandated that each federal agency make a transition to the use of metric units in all federal procurement, grants and business-related activities. National Gypsum Company, in complying with this order, provides a full line of gypsum board products in "hard" metric dimensions with regard to width and length. Standard board offerings are made in the width of 1200 mm and a length of 3600 mm. Job size lengths are available on a special order basis requiring minimum orders and extended lead times. Contact your local National Gypsum Company representative for further information. Thickness of gypsum board will be "soft" converted to the metric equivalent.

ENVIRONMENTAL CONDITIONS

Maintain a room temperature of not less than 40°F (4°C) during application of gypsum board except when adhesive is used for the attachment of gypsum board. For the bonding of adhesive, joint treatment, texturing, and decoration, the room temperature shall be maintained at least at 50°F (10°C) for 48 hours prior to application and continuously thereafter until completely dry.

Note 1: Precaution—When a temporary heat source is used, the temperature shall not exceed 95°F (35°C) in any given room or area.

Note 2: Precaution—Maintain adequate ventilation in the working area during installation and curing period.

Protect gypsum board products from direct exposure to rain, snow, sunlight, or other excessive weather conditions.

GUIDELINES FOR PREVENTION OF MOLD GROWTH ON GYPSUM BOARD

Gypsum board does not generate or support the growth of mold when it is properly transported, stored, handled, installed, and maintained. However, mold spores are present everywhere and when conditions are favorable, mold can grow on practically any surface. Observing these guidelines will help minimize the potential for mold growth on gypsum board. Gypsum board must be kept dry to prevent the growth of mold.

Transportation and Receiving

Gypsum board must be protected during transit with a weather-tight cover in good condition.

Plastic shipping bags are intended to provide protection during transit only and must be promptly removed upon arrival of the load. Failure to remove the shipping bag can increase the likelihood of developing conditions favorable to the growth of mold.

Storage and Handling

Gypsum board must be stored in an area that protects it from adverse weather conditions, condensation, and other forms of moisture.

Job site conditions that can expose gypsum board to water or moisture must be avoided.

Gypsum board must be delivered to the job site as near to the time it will be used as possible.

Application

Provisions must be made to keep gypsum board dry throughout application.

Gypsum board that has visible mold growth must not be used.

Gypsum board on walls must be applied with a minimum 1/4" (6.35 mm) gap between the gypsum board and the floor.

Gypsum board must not be applied over building materials where conditions exist that are favorable to mold growth.

Maintenance Following Application

Essential elements of sound weather tight building envelope must be properly maintained, such as the roof, sealants, windows, etc.

Immediate and appropriate remediation measures must be taken as soon as water leaks or condensation sources are identified.

Routine cleaning and maintenance operations must be performed so as to prevent saturation of the gypsum board.

Additional Sources of Information

The following Web sites provide information and recommendations for treating mold growth; other sites also provide similar suggestions.

California Indoor Air Quality Program at <http://www.cal-iaq.org/iaqsheet.html>

Federal Emergency Management Agency at <http://www.fema.gov/pdf/hazards/fststpbbr.html>

New York City Department of Health at <http://www.ci.nyc.ny.us/html/doh/html/epi/moldrpt1.html>

U. S. Environmental Protection Agency at <http://www.epa.gov/iedweb00/pubs/moldresources.html>

GA-238, Copyright Gypsum Association

LIMITATIONS

1. Maximum stud spacing for single layer application of 1/2" and 5/8" gypsum board is 24" o.c. If 3/8" gypsum board is used, it must be applied in two layers, with the second layer adhesively applied; 24" o.c. stud spacing may be used.
2. Where long, continuous runs of this wall system are employed, control joints must be provided every 30' or less.
3. Where structural movement may impose direct loads on these systems, isolation details are required.
4. Partitions should not be used where frequently exposed to excessive moisture unless all surfaces are waterproofed.
5. To prevent weakening due to calcining, gypsum board should not be exposed to temperatures over 125°F (52°C) for extended periods of time.
6. Gypsum board joints on single layer, or the face layer on two layer applications, shall not occur within 12" of the corners of door frames unless control joints are installed at the corners.
7. When gypsum board abuts concrete floors, cut board to allow for 1/8" to 1/4" clearance between board and floor to prevent potential wicking.

GOLD BOND® BRAND GRIDMARX®

DESCRIPTION

Gold Bond® BRAND Gypsum Board comes standard with GridMarX™ guide marks, printed on the paper surface. These guide marks align with standard building dimensions and help to quickly identify fastener lines for stud and joist framing. Using GridMarX, accurate cuts can be made without having to draw lines. GridMarX also assist with quick identification of nail/screw pattern.

GridMarX guide marks run the machine direction of the board at five points in 4" increments. Marks run along the edge in both tapers and at 16", 24" and 32" in the field of the board. The marks cover

easily with no bleed-through using standard paint products.

Vertical Application - In a vertical application, GridMarX serve as a **guide mark** to help identify the exact location of framing members behind the gypsum board, eliminating the need for field applied vertical lines.

Horizontal Application - In a horizontal application, GridMarX serve as a **reference mark** to help identify the location of framing members behind the gypsum board. (If framing member is located 2" to the right of the GridMarX at the top edge of the board, it will be located 2" to the right down the face of the board.)



DETAILS

GRIDMARX — VERTICAL WALL APPLICATION

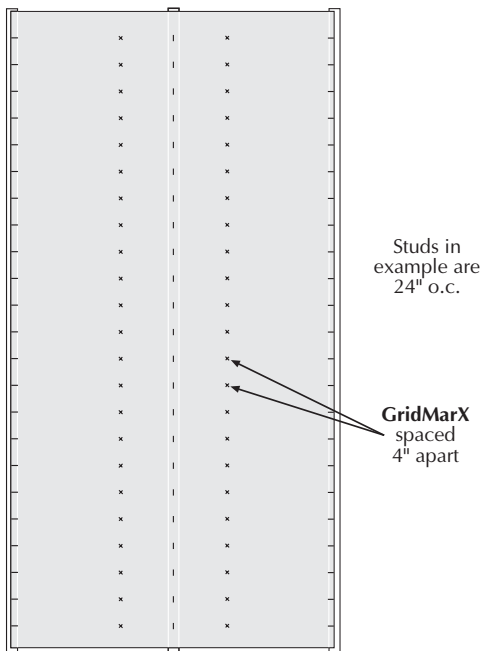

GRIDMARX — HORIZONTAL WALL AND CEILING APPLICATION

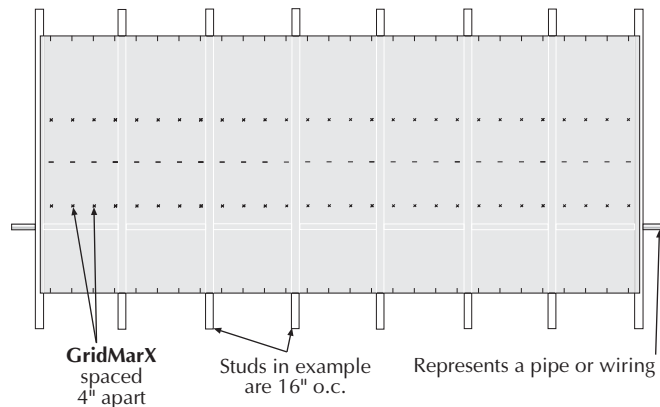

DESCRIPTION

Gypsum Board is the name for a family of board products consisting of a noncombustible core, primarily of gypsum, with a paper surfacing on the face, back and long edges.*

The popularity of gypsum board results from a number of factors. First, it takes virtually any decoration – from paint or textures to vinyl and paper laminates. It also lends itself to creative shaping of interior surfaces, allowing the maximum in design flexibility. Gypsum board is an economical alternative to other products. Because it is lightweight, it is easy to handle for speedy installation. With its natural properties, it is durable yet easy to repair. In addition, gypsum board's fire resistance and sound control capabilities further demonstrate its desirability in building systems.

Ever conscious of the environmental challenges we face in today's world, National Gypsum produces its gypsum board with 100 percent recycled paper on both the face and back.

Gold Bond gypsum board is available with a variety of edge configurations. For easy joint finishing, the tapered edge is preferred to provide a monolithic surface. Where joints will be exposed, square or beveled edges should be considered. National Gypsum also manufactures gypsum board with proprietary edge configurations made to accommodate a variety of wall systems and finishing techniques.

*GA-216

Fire and sound ratings for building systems utilizing gypsum board are dependent on the core type and thickness of the gypsum

TECHNICAL DATA

Fire and sound ratings for building systems utilizing gypsum board are dependent on the core type and thickness of the gypsum board, its application in conjunction with the component parts, and the manner in which it is applied.

Tests for fire resistance and sound transmission, performed by independent laboratories, have resulted in specific ratings for walls/partitions; floor/ceiling assemblies; shaftwalls, stairwells and area separation walls; and columns. For maximum fire resistance and sound control, double layer construction is generally recommended since the additional mass further retards heat and noise penetration.

Gypsum board can be installed to both metal and wood framing using nails, screws or adhesives in combination with nails or screws. In many instances, the application will dictate which fastening method is appropriate.

Control joints may be necessary to prevent cracking in the gypsum board facing of drywall systems, especially in areas where structural elements such as slabs, columns or exterior walls can bear directly on non-load-bearing partitions. To relieve the stresses which occur as a result of movement induced by changes in moisture, temperature or both, control joints are required in both partitions and ceilings.

GYPSUM BOARD INSULATING PROPERTIES

For purposes of calculating "U" values, the "C" factor for 1" gypsum board is 1.2; Resistance "R" for 3/8" board is .32; for 1/2" board .45; for 5/8" board .56 and for 1" board .83.

WEIGHTS

- 1/4" Regular - 1.2 lbs/SF
- 3/8" Regular - 1.2 lbs/SF
- 1/2" Regular - 1.6 lbs/SF

SPECIFICATIONS

THE FOLLOWING PARAGRAPHS ARE FOR INSERTION INTO SECTIONS OF GENERIC SPECIFICATIONS OR GENERIC/PROPRIETARY SPECIFICATIONS COVERING GYPSUM BOARD PRODUCTS. THE NATIONAL GYPSUM PRODUCT NAME FOLLOWS THE GENERIC DESCRIPTION IN PARENTHESES.

PART 2 PRODUCTS 2.01 MATERIALS

A. Regular Gypsum Board: A gypsum core board that is fire resistant and surfaced with paper on front/back and long edges and complies with ASTM C 1396.

1. Thickness: 1/4", 3/8", 1/2" (Gold Bond BRAND Gypsum Board)
2. Width: 4'
3. Length: 6' through 16'.
4. Edges: Square, Tapered, or Beveled Tapered (Sta-Smooth Edge).

PART 3 EXECUTION 3.01 INSTALLATION

A. General: In accordance with the manufacturer's recommendations, National Gypsum Company "Gypsum Construction Guide."

RECOMMENDATIONS

Examine and inspect materials to which gypsum board is to be applied. Remedy all defects prior to installation of drywall. Any defects in the finished installation due to misaligned framing or other cause will be the responsibility of the work performed under that section of the specification and such defects shall be remedied under that section of the specification.

Gypsum board shall be applied first to ceiling at right angles to framing members, then to walls. Boards of maximum practical length shall be used so that an absolute minimum number of end joints occur. Board edges shall be brought into contact with each other but shall not be forced into place.

Gypsum board joints at openings shall be located so that no end joint will align

with edges of opening unless control joints will be installed at these points. End joints shall be staggered, and joints on opposite sides of a partition shall not occur on the same stud.

Gypsum board shall be held in firm contact with the framing member while fasteners are being driven. Fastening shall proceed from center portion of the board toward the edges and ends. Fasteners shall be set with the heads slightly below the surface of the board in a dimple formed by the hammer or power screwdriver. Care shall be taken to avoid breaking the face paper of the gypsum board. Improperly driven nails or screws shall be removed.

See page 63, *Environmental Conditions and Limitations.*

CURVED SURFACES

To apply gypsum board over a curved surface, place a stop at one end of the board and then gently and gradually push on the other end, forcing the center against the framing until the curve is complete. Shorter radii than shown in the table may be obtained by moistening the face and back papers of the board with water, stacking on a flat surface, and allowing the water to soak into the core for at least one hour. When the board is dry it will regain its original hardness.

Gypsum board may be applied to curved surfaces in accordance with the following:

GYPSUM BOARD BENDING RADII

Thickness	Bending Lengthwise	Bending Widthwise
1/4" (6.4 mm)	5'-0" (1524 mm)	15'-0" (4572 mm)
3/8" (9.4 mm)	7'-6" (2286 mm)	25'-0" (7620 mm)
1/2" (12.7 mm)	*10'-0" (3048 mm)	
5/8" (15.9 mm)	15'-0" (4572 mm)	

*Bending two layers of 1/4" (6.4 mm) board successively will permit a bending radius shown for 1/4" (6.4 mm) board.

Note: To achieve tighter bending radii, use Gold Bond 1/4" High Flex Gypsum Board. See page 75 for additional information and 1/4" High Flex minimum bending radii chart.

SURFACE BURNING CHARACTERISTICS (Fire Hazard Classification) Tested in accordance with ASTM E 84

	Gypsum Board	Gypsum Sheathing	Durasan All Standard Patterns
Flame Spread Index	15	20	25 or less
Smoke Developed	0	0	50 or less

Gold Bond® BRAND Fire-Shield® Gypsum Board

DESCRIPTION

Gold Bond® BRAND Fire-Shield® Gypsum Board was developed to work in combination with other products in an assembly to retard heat transfer through the assembly. Fire-Shield gypsum boards are made with cores formulated to offer greater fire resistance than regular gypsum board. Generically, these fire resistant boards that are used to delay heat transfer to structural members are designated as "type X" products.

The Gypsum core of Fire-Shield Gypsum Board works as a natural "sprinkler system." Gypsum naturally contains about 21 percent water. When the board is heated, the water in the core begins to evaporate and is released as steam, retarding heat transfer. Fire-Shield gypsum board remains noncombustible. However, as shrinkage occurs because of the loss of water volume, cracks occur which permit passage of fire and heat. To lessen this process, Fire-Shield gypsum board is formulated by adding noncombustible fibers to the gypsum to help maintain the integrity of the core as water volume is lost while providing greater resistance to heat transfer.

TECHNICAL DATA

SYSTEM BURNING CHARACTERISTICS

ASTM E84
Flame Spread: 15
Smoke Developed: 0

According to ASTM C 1396, the standard for gypsum board, type X gypsum board must provide at least: a one-hour fire resistance rating for 5/8" board, or a 3/4-hour fire resistance rating for 1/2" board applied in a single layer nailed on each face of load-bearing wood framing members when tested in accordance with the requirements of Methods of Fire Test of Building Constructions and Materials (ASTM designation E 119).

For additional fire protection, Gold Bond Fire-Shield C products are formulated with a mineral core additive which expands when subjected to heat which aids in holding the gypsum board together.

Fire-Shield gypsum boards also can be used as column protection, delaying the rapid transfer of heat to reduce the likelihood that structural members will lose strength and fail to carry the intended load.

FIRE RESISTANCE RATINGS

Fire resistance ratings represent the results of tests on assemblies made up of specific materials in a specific configuration. When selecting construction designs to meet certain fire resistance requirements, caution must be used to insure that each component of the assembly is the one specified in the test. Further, precaution should be taken that assembly procedures are in accordance with those of the tested assembly. (For copies of specific tests, call 1-800-NATIONAL.)

WEIGHTS

1/2" Type C - 1.9 lbs/SF
5/8" Type X - 2.2 lbs/SF
5/8" Type C - 2.2 lbs/SF

For fire safety information, go to www.nationalgypsum.com.

RECOMMENDATIONS

Examine and inspect materials to which gypsum board is to be applied. Remedy all defects prior to installation of drywall. Any defects in the finished installation due to misaligned framing or other cause will be the responsibility of the work performed under that section of the specification and such defects shall be remedied under that section of the specification.

Gypsum board shall be applied first to ceiling at right angles to framing members, then to walls. Boards of maximum practical length shall be used so that an absolute minimum number of end joints occur. Board edges shall be brought into contact with each other but shall not be forced into place.

SPECIFICATIONS

THE FOLLOWING PARAGRAPHS ARE FOR INSERTION INTO SECTIONS OF GENERIC SPECIFICATIONS OR GENERIC/PROPRIETARY SPECIFICATIONS COVERING GYPSUM BOARD PRODUCTS. THE NATIONAL GYPSUM PRODUCT NAME FOLLOWS THE GENERIC DESCRIPTION IN PARENTHESES.

PART 2 PRODUCTS

2.01 MATERIALS

- A. Fire-Resistant Gypsum Board: A gypsum core gypsum board with additives to enhance fire resistance of the core and surfaced with paper on front, back, and long edges and complying with ASTM C 1396, type X.
1. Thickness: 1/2" (Gold Bond BRAND Fire-Shield C Gypsum Board), 5/8" (Gold Bond BRAND Fire-Shield Gypsum Board), or 5/8" (Gold Bond BRAND Fire-Shield C Gypsum Board)
 2. Width: 4'
 3. Length: 6' through 16'
(1/2" Fire-Shield C Gypsum Board,
5/8" Fire-Shield Gypsum Board)
Length: 8' through 14'
(5/8" Fire-Shield C Gypsum Board)
 4. Edges: Square, Tapered, or Beveled Tapered (Sta-Smooth Edge)

PART 3 EXECUTION

3.01 INSTALLATION

- A. General: In accordance with the manufacturer's recommendations, National Gypsum Company "Gypsum Construction Guide."

Gypsum board joints at openings shall be located so that no end joint will align with edges of opening unless control joints will be installed at these points. End joints shall be staggered, and joints on opposite sides of a partition shall not occur on the same stud.

Gypsum board shall be held in firm contact with the framing member while fasteners are being driven. Fastening shall proceed from center portion of the board toward the edges and ends. Fasteners shall be set with the heads slightly below the surface of the gypsum board in a dimple formed by the hammer or power screwdriver. Care shall be taken to avoid breaking the face paper of the gypsum board. Improperly driven nails or screws shall be removed.

See page 63, Environmental Conditions and Limitations.

DESCRIPTION

Sta-Smooth is a drywall system offering maximum joint strength and easy application. It can be used in any gypsum drywall system where conventional types of gypsum board are recommended. This system features Sta-Smooth Brand gypsum board with a unique edge. The two edge configurations relieve joint deformity problems caused by twisted framing, damaged gypsum board edges, poor alignment and extremes in humidity and temperature. Regular Sta-Smooth Boards are available in 1/2" thicknesses, 4' wide and in customary gypsum board lengths. The Sta-Smooth System is also composed of ProForm BRAND Sta-Smooth Joint Compounds, a hardening-type taping compound and regular Gold Bond tape and finishing compounds.

ADVANTAGES

Improved Durability – The Sta-Smooth System produces a smooth, flat, durable surface that relieves beading, ridging and other joint deformity problems.

Greater Speed – All flat joints in the Sta-Smooth System are filled and taped with any Sta-Smooth Compounds all in one easy operation, the same as conventional gypsum board application methods. Sta-Smooth Compounds or regular compounds can be used to tape inside corners, cornerbeads, and spot fasteners. Regular ProForm finishing compounds or Sta-Smooth compounds are used for the remaining finishing coats.

Easier Handling – The improved edge designs on Sta-Smooth Boards makes handling easier with greater comfort to the hands.

No Special Equipment – All conventional fasteners, adhesives, and gypsum board application tools (T-squares, knives, etc.) can be used to apply Sta-Smooth Boards. Nothing new to buy.

Alignment – Sta-Smooth board with its unique edge (either configuration) allows for easy alignment of the boards in the same way as conventional tapered edge board. The taper is scientifically designed to reduce crowned joints.

Stronger Bond – The bonding area of the Sta-Smooth Joint Compounds are increased with the "V" edge boards. The Sta-Smooth Joint Compound used to bond the joint tape and fill the joints is a hardening-type, high density material with low shrinkage characteristics.

Strength – The Sta-Smooth joint shape and the joint compound are developed to provide greater mass and integral bond for increased strength. Sta-Smooth Joint Compounds add considerable strength which is unaffected by the amount of moisture normally introduced into a structure that could cause ridging or beading with conventional joint compounds.

Cost – If application techniques are followed as recommended, the Sta-Smooth System should cost no more and can cost considerably less than conventional gypsum board drywall joint finishing. The initial savings are immediately demonstrated with reduced travel time that results from this perfected 2-trip, 3-step joint finishing system. Future cost savings will be realized with reduced callbacks.

Better Butt Joints – Recommended with the Sta-Smooth System is an improved technique for providing a smoother, flatter, stronger butt joint. Although this technique could be used in conventional drywall work and produce better butt joints, it is further improved by the use of the high strength Sta-Smooth Compound.

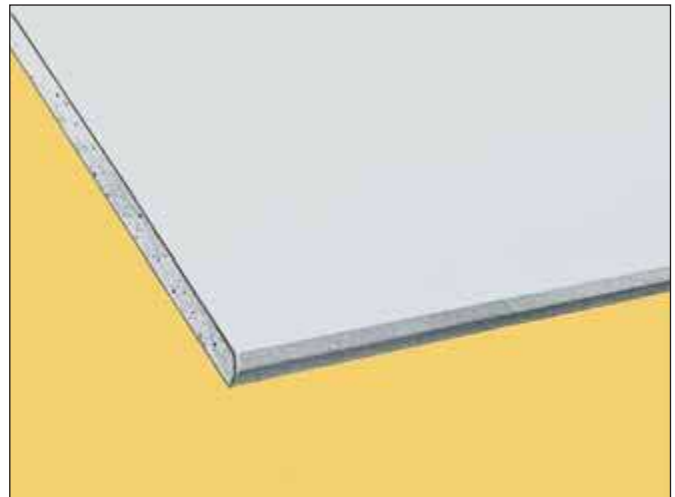

Easier Scheduling – Taping with Sta-Smooth Compounds and applying the first finishing coat, even before the Sta-Smooth used for taping has dried, allows easier job scheduling for the drywall contractor and finisher. This is particularly advantageous under slow drying conditions.

TECHNICAL DATA

SURFACE BURNING CHARACTERISTICS

ASTM E-84
Flame Spread: 15
Smoke Developed: 0

WEIGHTS

1/2" Regular - 1.6 lbs/SF
5/8" Type X - 2.2 lbs/SF
5/8" Type C - 2.2 lbs/SF

DETAILS

THE SECRET IS IN THE SHAPE OF THE JOINT AND THE STRENGTH OF THE COMPOUND



Standard tapered-beveled edge configuration.



Round edge configuration.

The Sta-Smooth System produces a superior joint because the Sta-Smooth Compounds are a hardening-type compound that is not affected by humidity once it has hardened and dried. It also maintains its hard core even with moisture added by the use of the regular joint compounds for the finishing work. Sta-Smooth Compound firmly bonds the tape to the board and the board "V" edges to each other making a strong, rigidized joint.

Consult your local National Gypsum sales representative for edge configuration available in your market.

09 29 00

RECOMMENDATIONS

Note: Sta-Smooth Gypsum Board may be used with any of the Gypsum Drywall Systems described in this Gypsum Construction Guide.

All specifications for the application of gypsum board as described in this literature may also serve for the application of Sta-Smooth Boards. Any deviation from these specifications is as indicated below.

- A. BOARD APPLICATION:** Position each Sta-Smooth Board so that the long edges are in light contact with the edges of the previous boards. All boards positioned to form butt joints should have a gap approximately 1/16" between the board ends. This spacing can be assured by driving 2 extra fasteners at the end of the board to act as temporary spacers before abutting the next board. When the boards are fastened in place, drive the temporary spacers flush with surface. When gypsum board is applied horizontally, recess all butt joints on the job by shimming the face of the studs (or joists), on both sides of the studs (or joists), on which the joint will fall. The shim can be pressed paper, thickness of building felt or other suitable materials not to exceed 1/16" thickness and as wide as the stud or joist. It should be 6" longer than the butt joint and applied to the face of the stud or joist with staples or nails allowing the shim to extend under the edge of the abutting boards of gypsum board to assure that the board facings remain on the same plane.
- B. CORNERS AND OPENINGS:** All exterior corners and all openings that require joint treatment should receive protective reinforcement of ProForm Multi-Flex Tape Bead or Steel Cornerbead or Steel Casing Bead as required.
- C. TREATMENT OF JOINTS*:** All flat Sta-Smooth gypsum board joints are taped with ProForm BRAND Sta-Smooth Compounds, making sure that a sufficient amount of compound is forced into the "V" joint and spread under the tape to form a solid foundation for the finishing coats.**
1. As soon as the Sta-Smooth Joint Compound used for taping has hardened, the first finishing coat can be applied even when the Sta-Smooth Compound is still wet.
 2. When the first finishing coat is completely dry the second finishing coat can be applied. Any of the ProForm Joint Compounds may be used for the finishing coats.
 3. Sta-Smooth Joint Compounds are recommended for the first coat on nail or screw heads. Regular finishing compounds may be used for subsequent spotting of the fasteners. Sta-Smooth Compounds are also recommended for the first coat on cornerbead and followed by one or more finishing coats as required of regular ProForm Joint or Topping Compounds.
 4. The inside corners may be treated with any of the ProForm Joint Treatment Compounds recommended for taping. If a two-trip joint treatment operation is planned, the inside corners are taped with Sta-Smooth Joint Compounds. This will permit finishing one side of the inside corners the first day. Cornerbead is treated with Sta-Smooth Compounds if a two-trip operation is employed.

*Alternate Method: When mechanical tools are to be used for taping joints, Sta-Smooth Compounds are used to fill the "V" joint only. Other ProForm Joint Compounds are then used to bed the tape and finish the joints. (See page 69.)

**Sta-Smooth, Sta-Smooth HS and Sta-Smooth Lite Joint Compounds are recommended for pre-fill or tape/bed coat operations in the Sta-Smooth system.

See page 63, *Environmental Conditions and Limitations*.

SPECIFICATIONS

THE FOLLOWING PARAGRAPHS ARE FOR INSERTION INTO SECTIONS OF GENERIC SPECIFICATIONS OR GENERIC/PROPRIETARY SPECIFICATIONS COVERING GYPSUM BOARD PRODUCTS. THE NATIONAL GYPSUM PRODUCT NAME FOLLOWS THE GENERIC DESCRIPTION IN PARENTHESES.

PART 2 PRODUCTS

2.01 MATERIALS

- A. Gypsum Board: A gypsum core wall board surfaced with paper on front, back, and long edges and complying with ASTM C 1396 (Gold Bond BRAND Gypsum Board).
1. Thickness: 1/2"
 2. Width: 4'
 3. Length: 6' through 16'
 4. Edge: Beveled Tapered (Sta-Smooth Edge)
- B. Fire-Resistant Gypsum Board: A gypsum core wall board with additives to enhance fire resistance of the core and surfaced with paper on front, back, and long edges and complying with ASTM C 1396, type X.
1. Thickness: 1/2" (Gold Bond BRAND Fire-Shield C Gypsum Board), 5/8" (Gold Bond BRAND Fire-Shield Gypsum Board), or 5/8" (Gold Bond BRAND Fire-Shield C Gypsum Board)
 2. Width: 4'
 3. Length: 6' through 16'
(1/2" Fire-Shield C Gypsum Board,
5/8" Fire-Shield C Gypsum Board)
 - Length: 8' through 14'
(5/8" Fire-Shield C Gypsum Board)
 4. Edge: Beveled Tapered (Sta-Smooth Edge)
 5. Edge: Rounded (Sta-Smooth Edge)
- C. Exterior Gypsum Soffit Board: A gypsum core soffit board with additives to enhance the sag resistance of the core; surfaced with water repellent paper on front, back, and long edges; and complying with ASTM C 1396 (Gold Bond BRAND Exterior Soffit Board).
1. Thickness: 1/2"
 2. Width: 4'
 3. Length: 8' through 12'
 4. Edge: Beveled Tapered (Sta-Smooth Edge)
- D. Fire-Resistant Exterior Gypsum Soffit Board: A gypsum core soffit board with additives to enhance the fire-resistance and the sag resistance of the core; surfaced with water repellent paper on front, back, and long edges; and complying with ASTM C 1396, type X (Gold Bond BRAND Fire-Shield Exterior Soffit Board).
1. Thickness: 5/8"
 2. Width: 4'
 3. Length: 8' through 12'
 4. Edge: Beveled Tapered (Sta-Smooth Edge)

PART 3 EXECUTION

3.01 INSTALLATION

- A. General: In accordance with the manufacturer's recommendations, National Gypsum Company "Gypsum Construction Guide."

INSTALLATION



Application And Fastening



1. Fill Joint And Bed Tape Simultaneously



2. First Finishing Coat



3. Second Finishing Coat

APPLICATION AND FASTENING

Sta-Smooth Boards may be nailed, screwed or adhesively applied to wood studs or furring, or screwed or adhesively applied to steel studs or furring, using conventional type and length of fastener. All fasteners shall be applied a minimum of 3/8" (maximum 1/2") from the edges and ends of each board. Then treat the joints in three simple steps.

CONVENTIONAL TAPING AND FINISHING

1. Fill Joint And Bed Tape Simultaneously

All flat gypsum board joints are to be filled and taped in one operation with ProForm BRAND Sta-Smooth Compounds, using ProForm Paper Tape in the conventional manner. When Sta-Smooth HS tape is used, the self-adhering fiberglass mesh tape is firmly pressed to the gypsum board, spanning the joints. Sta-Smooth Compounds can then immediately be applied to the joints. The compound must be forced through the tape to fill the channel formed by the "V" edges of the Sta-Smooth gypsum board. All inside corners may be taped using regular ProForm compounds. Sta-Smooth Compounds are used for the first coat on nail or screw heads and will decrease problems with fastener imperfections. Inside angles, first and second finishing coats may be done using regular ProForm joint compounds.

2. First Finishing Coat

As soon as the Sta-Smooth Compound used for taping has hardened, the first finishing coat may be applied on the flat joints even before it is dry. Any ProForm joint compound may be used for this operation. A second coat may be applied at this time to nail or screw heads, one coat on cornerbead if Sta-Smooth Compound was used for the first coat.

3. Second Finishing Coat

As soon as the compounds used for the previous steps have thoroughly dried, a second finishing coat is applied to all flat joints using ProForm Joint Compound or Topping Compound. A third coat is applied over nail or screw heads and on cornerbead as required. The unfinished side of the inside corners is also finished at this time.

STA-SMOOTH ROUND EDGE REQUIRES PRE-FILLING PRIOR TO BED & TAPING

Application Instructions For Round Edge Sta-Smooth Gypsum Board

- 1) Mix Sta-Smooth Joint Compound, Sta-Smooth Lite Joint Compound or Sta-Smooth HS Joint Compound as per bag instructions. Care should be taken to mix no more compound than can be applied in the designated set time.
- 2) Pre-fill all joints formed by the abutting round edge Sta-Smooth Gypsum Boards with Sta-Smooth Compound, Sta-Smooth Lite Joint Compound or Sta-Smooth HS Joint Compounds using a conventional joint finishing knife. Fill joints, level and wipe off excess compound to the lowest level of the taper, allowing enough room for embedding the tape. Allow prefill material to harden prior to application of tape and bed coat.
- 3) Finish joints in the normal manner.

TAPING AND FINISHING WITH MECHANICAL TOOLS

Taping – Taping tools such as the "banjo" and "hopper" types are recommended for taping the flat joints with Sta-Smooth Compounds and the inside corners with ProForm regular joint compounds or with Sta-Smooth Compounds. **Automatic taping tools are not recommended for use with hardening-type compounds.** Mechanical tools can be used for taping the inside corners when a ProForm regular joint compound is used. When automatic taping tools are used for taping the flat joints, the "V" formed by the edges of Sta-Smooth board on the flat joints and all spaces between the gypsum board edges on butt joints are pre-filled with Sta-Smooth Compounds and allowed to harden (30 minutes longer than the set time designated on the bag) prior to taping with a regular ProForm joint compound.

Finishing – Mechanical type finishing tools can be used in the normal manner for the finishing operations of the Sta-Smooth System since conventional ProForm finishing compounds are used.

MIXING INSTRUCTIONS

ProForm BRAND Sta-Smooth Compounds are available in 20, 45, 90 and 210 minute set times. MIX NO MORE COMPOUND THAN CAN BE APPLIED IN THE DESIGNATED SET TIME. Contact your National Gypsum Company Representative for availability. A plastic container is recommended because of its ease in cleaning between batches. Do not use a wood or aluminum bucket. Add the compound gradually to clean water while stirring. Note: Use only fresh, clean water suitable for human consumption. Mix at the ratio of 13-14 pints of water to the 25 lb. bag. Mix the compound free of lumps with a mechanical mixer or by hand. Mechanical mixing is recommended. Allow to stand 5 minutes as a "wetting" period and remix to further improve the working qualities. If a slightly thinner compound is desired, add an additional pint of water, or less, after the compound is thoroughly mixed.

Gold Bond® BRAND XP® Gypsum Board

DESCRIPTION

Gold Bond® BRAND XP® Gypsum Board panels consist of a fire-resistant, mold and moisture-resistant gypsum core encased in heavy moisture/mold/mildew resistant, 100% recycled purple paper on the face and backsides. XP Gypsum Board was designed to provide extra protection against mold and mildew compared to standard gypsum board products. The face paper is folded around the long edges to reinforce and protect the core, and the ends are square-cut and finished smooth. Long edges of panels are tapered. Tapered edges allow joints to be treated in the normal manner. For optimum mold and mildew resistance, National Gypsum recommends ProForm BRAND XP Ready Mix or ProForm BRAND Sta-Smooth/Sta-Smooth Lite setting compounds.

Gold Bond BRAND XP Fire-Shield® Gypsum Board features a type X core to provide additional fire resistance ratings when used in tested systems.

Gold Bond BRAND XP Fire-Shield C Gypsum Board Panels have a specially formulated type X core to achieve superior performance when used in specific fire-rated assemblies where the weight and number of gypsum board layers are a concern.

TECHNICAL DATA

SURFACE BURNING CHARACTERISTICS

ASTM E 84
Flame spread: 15
Smoke developed: 0

FIRE RESISTANCE RATINGS

Fire resistance ratings represent the results of tests on assemblies made up of specific materials in a specific configuration. When selecting construction designs to meet certain fire resistance requirements, caution must be used to insure that each component of the assembly is the one specified in the test. Further, precaution should be taken that assembly procedures are in accordance with those of the tested assembly. (For copies of specific tests,

call 1-800-NATIONAL. For fire safety information, see www.nationalgypsum.com.)

MOLD AND MILDEW RESISTANCE

XP Gypsum Board was designed to provide extra protection against mold and mildew compared to standard gypsum board products. When tested by an independent lab per ASTM D3273 ("Standard Test Method for Resistance to Growth of Mold on the Surface of Interior Coatings in an Environmental Chamber"), XP Gypsum Board achieved a score of 10, the best possible score for this test.

The use of XP Gypsum Board in actual installations may not produce the same results as were achieved in controlled, laboratory conditions. No material can be considered "mold-proof," nor is it certain that any material will resist mold or mildew indefinitely. When used in conjunction with good design, handling and construction practices, XP Gypsum Board can provide increased mold resistance versus standard gypsum board products. As with any building material, exposure during handling, storage, and installation, and after installation is complete, is the best way to avoid the formation of mold or mildew.

WEIGHTS

1/2" Regular - 1.75 lbs/SF
1/2" Type C - 1.95 lbs/SF
5/8" Type X - 2.4 lbs/SF

RECOMMENDATIONS

Exposure to excessive or continuous moisture and extreme temperatures should be avoided. XP Gypsum Board is not recommended where it will be exposed to temperatures exceeding 125°F (52°C) for extended periods of time.

MAXIMUM FRAMING SPACING - For Single Layer XP Gypsum Board			
	Gypsum Board Thickness	Gypsum Board Orientation to Framing	Maximum Framing Spacing
Ceilings:	1/2" (12.7mm)	Parallel	16" (406mm) o.c.
	1/2" (12.7mm)	Perpendicular	24" (610mm) o.c.
	5/8" (15.9mm)	Parallel	16" (406mm) o.c.
Walls:	5/8" (15.9mm)	Perpendicular	24" (610mm) o.c.
	1/2" (12.7mm)	Perpendicular or Parallel	24" (610mm) o.c.
	5/8" (15.9mm)	Perpendicular or Parallel	24" (610mm) o.c.

NOTE: On ceilings to receive hand or spray applied, water based texture material, XP Gypsum Board products shall be applied perpendicular to framing.

XP Gypsum Board can be used as a tile backer board in dry areas or areas with limited water exposure such as directly behind tile in tub and shower areas.

XP Gypsum Board can be installed on the interior south face of exterior walls.

XP Gypsum Board should not be used as a backer board directly behind tile in tub and shower areas.

XP Gypsum Board should not be used in areas subject to constant and/or excessive moisture and high humidity such as gang showers, saunas, steam rooms and swimming pool enclosures. PermaBase BRAND cement board is recommended for these areas.

XP Gypsum Board must be stored off the ground and under cover. Sufficient risers must be used to ensure support for the entire length of the gypsum board to prevent sagging.

XP Gypsum Board must be kept dry to minimize the potential for mold growth. Adequate care should be taken while transporting, storing, applying and maintaining gypsum board. For additional information, refer to the Gypsum Association publication, "Guidelines for the Prevention of Mold Growth on Gypsum Board" (GA-238-03), which is available at www.gypsum.org under the "Download Free Gypsum Association Publications" section.

DECORATION

For best painting results, all surfaces, including joint compound, should be clean, dust-free and not glossy. To improve fastener and joint concealment, a coat of a quality drywall primer is recommended to equalize the porosities between the paper and joint compound.

The selection of a paint to give the specified or desired finished characteristics is the responsibility of the architect or contractor.

XP Gypsum Board that is to have a wallcovering applied to it should be prepared and primed as described for painting.

SPECIFICATIONS

PART 2 PRODUCTS

THE FOLLOWING PARAGRAPHS ARE FOR INSERTION INTO SECTIONS OF GENERIC SPECIFICATIONS OR GENERIC/PROPRIETARY SPECIFICATIONS COVERING GYPSUM BOARD PRODUCTS. THE NATIONAL GYPSUM PRODUCT NAME FOLLOWS THE GENERIC DESCRIPTION IN PARENTHESES.

2.01 MATERIALS

A. Mold-Resistant Gypsum Board: A gypsum core wall panel with additives to enhance the water resistance of the core; surfaced with moisture/mold/mildew resistant paper on front, back and long edges and complying with ASTM C 1396 (Gold Bond BRAND XP Gypsum Board).

1. Thickness: 1/2"
2. Width: 4'
3. Length: 8', 10' or 12'
4. Edges: Square or Tapered
5. Mold and Mildew Resistance: Panel score of 10 when tested in accordance with ASTM D 3273

B. Fire-Resistant Mold and Mildew-Resistant Gypsum Board: A gypsum core wall panel with additives to enhance the fire resistance and water resistance of the core; surfaced with moisture/mold/mildew resistant paper on front, back and long edges and complying with ASTM C 1396, type X.

1. Thickness: 1/2" (Gold Bond BRAND XP Fire-Shield C Gypsum Board), 5/8" (Gold Bond BRAND XP Fire-Shield Gypsum Board), 5/8" (Gold Bond Brand XP Fire-Shield C Gypsum Board.)
2. Width: 4'
3. Length: 8', 10', or 12'
4. Edges: Square or Tapered
5. Mold and Mildew Resistance: Panel score of 10 when tested in accordance with ASTM D 3273

PART 3 EXECUTION

3.01 INSTALLATION

A. General: In accordance with the manufacturer's recommendations, National Gypsum Company "Gypsum Construction Guide."

DESCRIPTION

Gold Bond® BRAND Exterior Soffit Board is designed to provide, in a fire-resistive gypsum board, the extra resistance to moisture and sagging required to meet outdoor conditions. The specially treated gypsum core is covered on both sides with water-repellent paper formed to the Sta-Smooth edge. Boards are 1/2" (regular) and 5/8" (Fire-Shield) x 4' x 8' through 12' lengths.

Typical uses for sheltered exterior ceiling and soffit areas are covered parking areas, walkways and marquees in commercial construction and, in residential construction, carports, breezeways and open porches.



TECHNICAL DATA

1. WEIGHTS

- 1/2" Regular - 1.8 lbs/SF
- 5/8" Type X - 2.2 lbs/SF

2. GENERAL

Use longest practical board lengths to minimize the number of butt joints. Position end joints at supports, allowing 1/16" to 1/8" between butted ends. When board is applied with long edges parallel to framing, framing spacing is 16" o.c. max. When board is applied with long edges perpendicular to framing, framing spacing may be up to 24" o.c. max. Drive fasteners to provide uniform dimples not over 1/32" deep.

3. WOOD FRAMING AND FURRING

Apply Soffit Board with the long edges at right angles to framing. Use Type "W" 1 1/4" Drywall Screws spaced 12" o.c. max. Electric screw gun should be equipped with adjustable depth control and a #2 Phillips bit. 1 1/2" galvanized box nails or 1 1/2" aluminum nails spaced 7" o.c. max., may be used if desired.

Wood furring 1" x 4" nom. may be used for screw application of board where support member spacing does not exceed 24" o.c. Furring 2" x 2" nom. must be used for nail application of board or when support member spacing exceeds 24" o.c. but is not greater than 48" o.c.

4. METAL FRAMING AND FURRING

A suspended framework for support of the ceiling board is composed of 1 1/2" cold-rolled steel channels for main runners and either the Furring Channel or the Steel Stud for cross-furring.

Space main runners as follows: 4' o.c. max. if Furring Channels are to be used, 6' o.c. max. for 2 1/2" Steel Studs, and 8' o.c. max. for 3 5/8" Steel Studs. Main runners are suspended with 8 gauge (min.) galvanized wire spaced 4' o.c. max.

Secure Furring Channels to main runners with 1 1/2" Furring Channel Clips, alternating sides at each intersection, or saddle tie with double strands of 16 gauge galvanized tie wire.

Secure Steel Stud furring to main runners with double strand 16 gauge tie wire 16" o.c. max. For added rigidity, nest an 8" length of track at each tie wire location.

Main runners and furring must have a minimum clearance between their ends and any abutting structural element. A main runner must be located within 6" of parallel walls. The ends of these runners must be supported by hangers not more than 6" from the ends. The closest edge of the furring member must be no more than 2" from the parallel wall. At any openings for vents, light fixtures, etc., that interrupt runners or furring, reinforcement must be provided to maintain

support equal to that of the interrupted members.

Apply Soffit Board with 1" Type "S" Screws, 12" o.c. max.

5. CONTROL JOINTS

To compensate for the effect of structural movement on large ceiling areas, control joints in the Ceiling/Soffit Board are recommended. These should be E-Z Strip Expansion Joints.

Install E-Z Strip with 1/2" min. staples 6" o.c. Use additional staples if necessary for snug contact with board. Install joints no more than 30' apart and, if possible, to coincide with expansion joints in the roof above. Control joints may be installed to intersect light fixture or other openings where stresses are usually concentrated. Wings of "L", "U", and "I" shaped areas should always be separated.

6. INTERSECTION WITH OTHER BUILDING ELEMENTS

Allow a minimum 1/4" space between ceiling board and any intersecting structure. Do not caulk this space. Install suitable trim moulding to conceal the gap or use J Casing Bead and flexible sealant.

7. BOARD EDGE PROTECTION

Install fascia so that its drip line is at least 1/4" below the Ceiling Soffit Board molding.

8. VENTILATION

Provide at least 1 sq. ft. of venting to exterior for each 150 sq. ft. of Ceiling/Soffit Board. Vent each enclosed bay. If the space above the ceiling board is not open to areas above or below habitable rooms, provide ventilating area of not less than 1/300 of the ceiling area. Otherwise, vent in accordance with HUD Minimum Property Standard No. 4900.1 or in accordance with local codes.

9. JOINT TREATMENT

ProForm BRAND Sta-Smooth Joint Compound is required for filling, taping and finishing. Since Sta-Smooth is a setting material, cut any high points while still wet and wet sand as necessary.

10. PAINTING

The surface of the Soffit Board should be painted with two coats of exterior paint as soon as joint compound is dry, about one week after joints are completed.

09 29 00

DETAILS

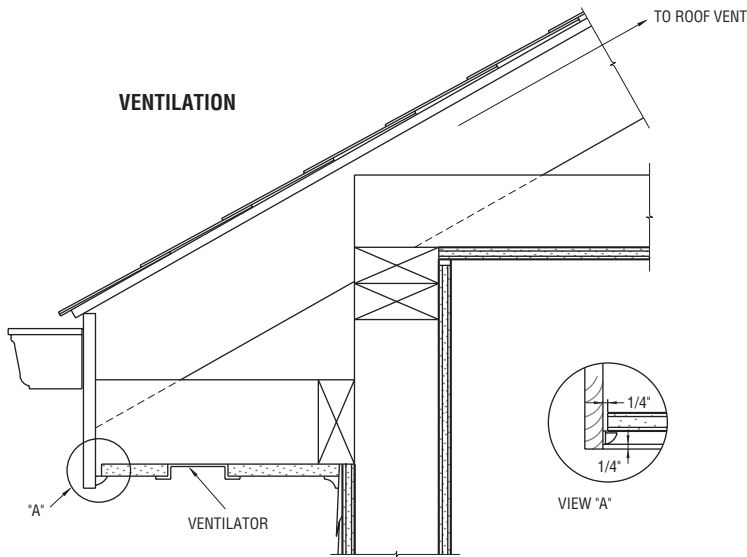

EXTERIOR SOFFIT BOARD VENTILATION

09250A
Scale: 1 1/2" = 1'-0"

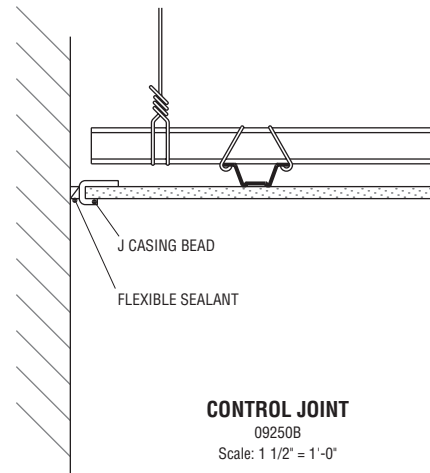

CONTROL JOINT

09250B
Scale: 1 1/2" = 1'-0"

INSTALLATION

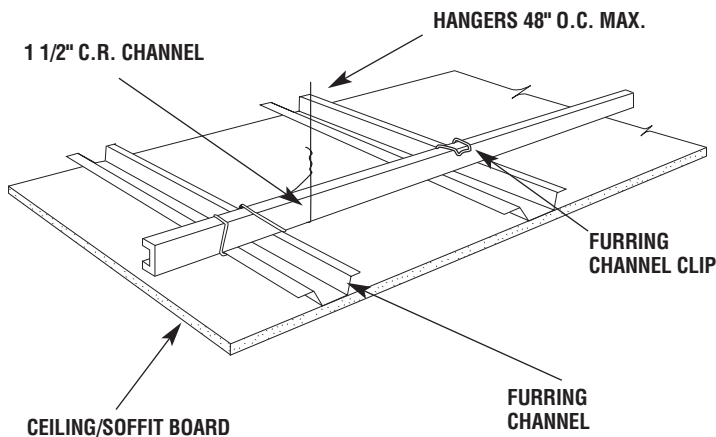

RECOMMENDATIONS

Installation of Gold Bond Exterior Soffit Board should be in accordance with page 70 of the National Gypsum Company "Gypsum Construction Guide."

A qualified structural engineer should evaluate design, including uplift bracing.

See page 63, *Environmental Conditions and Limitations*.

SPECIFICATIONS

THE FOLLOWING PARAGRAPHS ARE FOR INSERTION INTO SECTIONS OF GENERIC SPECIFICATIONS OR GENERIC/PROPRIETARY SPECIFICATIONS COVERING GYPSUM BOARD PRODUCTS. THE NATIONAL GYPSUM PRODUCT NAME FOLLOWS THE GENERIC DESCRIPTION IN PARENTHESES.

PART 2 PRODUCTS

2.01 MATERIALS

- A. Exterior Gypsum Soffit Board: A gypsum core soffit board with additives to enhance the sag resistance of the core; surfaced with water repellent paper on front, back, and long edges; and complying with ASTM C 1396 (Gold Bond BRAND Exterior Soffit Board).

1. Thickness: 1/2"
2. Width: 4'
3. Length: 8' through 12'
4. Edges: Beveled Tapered (Sta-Smooth Edge)

- B. Fire-Resistant Exterior Gypsum Soffit Board: A gypsum core soffit board with additives to enhance the fire resistance of the core; surfaced with water repellent paper on front, back, and long edges; and complying with ASTM C 1396, type X (Gold Bond BRAND Fire-Shield Exterior Soffit Board).

1. Thickness: 5/8"
2. Width: 4'
3. Length: 8' through 12'
4. Edges: Beveled Tapered (Sta-Smooth Edge)

PART 3 EXECUTION

3.01 INSTALLATION

- A. General: In accordance with the manufacturer's recommendations, National Gypsum Company "Gypsum Construction Guide."

DESCRIPTION

Gold Bond® BRAND 1" Fire-Shield Shaftliner panels consist of a fire-resistant type X gypsum core encased in a heavy moisture-resistant green, 100% recycled paper on the face and back sides. The face paper is folded around the long edges to reinforce and protect the core, and the ends are square-cut and finished smooth. Long edges of panels are beveled for ease of installation.

1" Shaftliner panels are designed to be used to construct lightweight fire barriers for cavity shafts and area separation walls in multifamily housing. The panels are key components in the Cavity Shaftwall Systems and the I-Stud and H-Stud Area Separation Wall Systems.

TECHNICAL DATA

SURFACE BURNING CHARACTERISTICS

ASTM E84
 Flame Spread: 15
 Smoke Developed: 0

WEIGHTS

1" Shaftliner - 3.75 lbs/SF

FIRE RESISTANCE RATINGS

Fire resistance ratings represent the results of tests on assemblies made up of materials authorized by National Gypsum in specific configurations. When selecting construction designs to meet certain fire requirements, caution must be used to ensure that each component of the assembly is the one specified in the test.

Further, precaution should be taken that assembly procedures are in accordance with those of the tested assembly. (For copies of specific tests, call 1-800-NATIONAL.)

RECOMMENDATIONS

Installation of 1" Fire-Shield Shaftliner should be consistent with methods described in specific application details for Cavity Shaftwall Systems or H-Stud Area Separation Wall Systems or other fire-rated designs shown in National Gypsum Company "Gypsum Construction Guide."

Exposure to excessive or continuous moisture or standing water and extreme temperatures should be avoided.

To prevent weakening due to calcining, 1" Fire-Shield Shaftliner panels, like any gypsum board, should not be exposed to temperatures over 125°F (52°C) for extended periods of time.

Not to be used in an unlined air supply duct.

Always store Shaftliner Gypsum Panels flat on a level surface and support with properly placed risers. Care should be taken to avoid impact, unwarranted flexing and subsequent damage to board edges, ends and corners.

SPECIFICATIONS

THE FOLLOWING PARAGRAPHS ARE FOR INSERTION INTO SECTIONS OF GENERIC SPECIFICATIONS OR GENERIC/PROPRIETARY SPECIFICATIONS COVERING GYPSUM BOARD PRODUCTS. THE NATIONAL GYPSUM PRODUCT NAME FOLLOWS THE GENERIC DESCRIPTION IN PARENTHESES.

PART 2 PRODUCTS

2.01 MATERIALS

- A. Fire-Resistant Gypsum Shaftliner Board: A gypsum core shaftwall board with additives to enhance fire resistance of the core and surfaced with water resistant paper on front, back and long edges; and complying with ASTM C 1396, type X (Gold Bond BRAND Fire-Shield Shaftliner).
 1. Thickness: 1"
 2. Width: 2'
 3. Length: 7' through 14'
 4. Edges: Beveled

PART 3 EXECUTION

3.01 INSTALLATION

- A. General: In accordance with the manufacturer's recommendations, National Gypsum Company "Gypsum Construction Guide."

Gold Bond® BRAND 1" Fire-Shield® Shaftliner XP®

DESCRIPTION

Shaftliner XP™ Gypsum Panels consist of a mold and fire-resistant type X gypsum core encased in a heavy moisture/mold/mildew-resistant, 100% recycled purple paper on the face and back sides. Shaftliner XP was designed to provide extra protection against mold and mildew. The face paper is folded around the long edges to reinforce and protect the core, and the ends are square-cut and finished smooth. Long edges of panels are beveled for ease of installation.

1" Shaftliner XP Panels are designed to be used to construct lightweight fire barriers for cavity shaft walls and area separation walls in multifamily housing. The panels are key components in Cavity Shaftwall Systems and H-Stud Area Separation Wall Systems.

TECHNICAL DATA

SURFACE BURNING CHARACTERISTICS

ASTM E84
Flame Spread: 15
Smoke Developed: 0

WEIGHT

1" XP - 3.75 lbs/SF

FIRE RESISTANCE RATINGS

Fire resistance ratings represent the results of tests on assemblies made up of materials authorized by National Gypsum in specific configurations. When selecting construction designs to meet certain fire requirements, caution must be used to ensure that each component of the assembly is the one specified in the test. Further, precaution should be taken that assembly procedures are in accordance with those of the tested assembly. (For copies of specific tests, call 1-800-NATIONAL)

MOLD AND MILDEW RESISTANCE

Shaftliner XP was designed to provide extra protection against mold and mildew.

When tested by an independent lab per ASTM D3273 (Standard Test Method for Resistance to Growth of Mold on the Surface of Interior Coatings in an Environmental Chamber), Shaftliner XP achieved a score of 10, the best possible score for this test.

The use of Shaftliner XP in actual installations may not produce the same results as were achieved in controlled, laboratory conditions. No material can be considered "mold proof," nor is it certain that any material will resist mold indefinitely. When used in conjunction with good design, handling and construction practices, Shaftliner XP can provide increased mold resistance versus standard shaftliner products. As with any building material, avoiding water exposure during handling, storage and installation, and after installation is complete, is the best way to avoid the formation of mold or mildew.

RECOMMENDATIONS

Installation of 1" Shaftliner XP Gypsum Panels should be consistent with methods described in specific application details for Cavity Shaftwall Systems, or H-Stud Area Separation Wall Systems, or other fire-rated designs shown in National Gypsum Company "Gypsum Construction Guide."

Exposure to excessive or continuous moisture or standing water and extreme temperatures should be avoided.

To prevent weakening due to calcining, 1" Fire-Shield Shaftliner panels, like any gypsum board, should not be exposed to temperatures over 125°F (52°C) for extended periods of time.

Not to be used in an unlined air supply duct.

Always store Shaftliner XP Gypsum Panels flat on a level surface, and support with properly placed risers. to Growth of Mold on the Surface of Interior Coatings.

Care should be taken to avoid impact, unwarranted flexing and subsequent damage to board edges, ends and corners.

Shaftliner XP may be substituted for National Gypsum's Gold Bold BRAND Fire-Shield Shaftliner in Cavity Shaftwall, Area Separation Wall Systems and solid laminated partitions.

SPECIFICATIONS

THE FOLLOWING PARAGRAPHS ARE FOR INSERTION INTO SECTIONS OF GENERIC SPECIFICATIONS OR GENERIC/PROPRIETARY SPECIFICATIONS COVERING GYPSUM BOARD PRODUCTS. THE NATIONAL GYPSUM PRODUCT NAME FOLLOWS THE GENERIC DESCRIPTION IN PARENTHESES.

PART 2 PRODUCTS

2.01 MATERIALS

A. Fire and Mold-Resistant Gypsum Shaftliner Board: A gypsum core shaftwall board with additives to enhance fire resistance of the core and surfaced with a moisture/mold/mildew resistant paper on front, back and long edges; and complying with ASTM C1396, Type X (Gold Bond BRAND Fire-Shield Shaftliner XP).

1. Thickness: 1"
2. Width: 2'
3. Length: 7' through 14'
4. Edges: Beveled
5. Mold and Mildew Resistance: Panel score of 10 when tested in accordance with ASTM D3273.

PART 3 EXECUTION

3.01 INSTALLATION

A. General: In accordance with the manufacturer's recommendations, National Gypsum Company "Gypsum Construction Guide."

DESCRIPTION

Gold Bond BRAND High Flex Gypsum Board consists of a fire-resistive gypsum core encased in heavy natural-finish paper on the face side and strong liner paper on the back side. The face paper is folded around the long edges to reinforce and protect the core and the ends are square-cut and finished smooth. Long edges of boards are slightly tapered, allowing joints to be reinforced and concealed with ProForm Joint Tape and Joint Treatment Compounds.

1/4" High Flex Gypsum Board is specifically designed for radius construction such as curved walls, archways and stairways. It can be used for both concave and convex surfaces. 1/4" High Flex is typically applied in double layers.

1/4" High Flex Gypsum Board is a lightweight, cost-efficient material that readily accepts a wide range of decorative finishes.

1/4" High Flex Gypsum Board is easily cut for quick installation, permitting painting or other decoration and the installation of metal or wood trim almost immediately.

The gypsum core is non-combustible.

With joints reinforced by ProForm BRAND Joint Compounds, Gold Bond Gypsum Board forms walls and ceilings exceptionally resistant to cracks caused by structural and thermal changes.

Expansion and contraction under normal atmospheric changes is negligible.

TECHNICAL DATA

SURFACE BURNING CHARACTERISTICS

ASTM E 84
Flame spread: 15
Smoke developed: 0

WEIGHT

1/4" High Flex - .95 lbs/SF

RECOMMENDATIONS

Installation of Gold Bond BRAND gypsum board should be consistent with methods described in GA216

"Recommended Specifications for the Application of Gypsum Board," ASTM C 840, "Standard Specifications for Application and Finishing of Gypsum Board," and GA214, "Recommended Levels of Gypsum Board Finish."

Exposure to extreme temperatures should be avoided. 1/4" High Flex Gypsum Board is not recommended where it will be exposed to temperatures exceeding 125°F.

Installing 1/4" High Flex Gypsum Board over an insulating blanket, installed continuously across the face of the framing members, is not recommended. Blankets should be recessed and flanges attached to the sides of the studs or joists.

For best painting results, all surfaces, including joint compound, should be clean, dust-free and not glossy. To improve fastener and joint concealment, a coat of a quality latex primer is recommended to equalize the absorption between surface paper and joint compound.

1/4" High Flex Gypsum Board should be applied first to ceiling at right angles to framing members, then to walls. Boards of maximum practical length should be used so that an absolute minimum number of end joints occur. Board edges should be brought into contact with each other but should not be forced into place.

1/4" High Flex Gypsum Board is significantly more flexible in the vertical direction (long edges parallel to the framing) than in the horizontal direction. (See Table 1.)

Gypsum board joints at openings should be located so that no end joint will align with edges of openings unless control joints will be installed at these points. End joints should be staggered, and joints on opposite sides of a partition should not occur on the same stud.

1/4" High Flex Gypsum Board is typically installed in double layer construction. To prevent flat spots, framing members should be

spaced closer together than required for typical flat wall and ceiling surfaces (see Table 1). 1/4" High Flex Gypsum Board should be held in firm contact with the framing member while fasteners are being driven.

For concave surfaces, a stop shall be applied to one end of the curve to restrain one end or edge of the board during installation. Pressure shall be applied to the unrestrained end or edge of the gypsum board forcing the field of the gypsum board into firm contact with the framing. Gypsum board shall be fastened by working from the "stopped" end or edge. The gypsum board shall be held tightly against the framing while fasteners are being driven.

For convex surfaces, one end of the gypsum board shall be attached to the framing with nails or screws. The gypsum board shall be progressively pushed into contact with the framing members, working from the fixed end to the free end. The gypsum board shall be held tightly against each framing member while fasteners are being driven.

Fasteners should be set with the heads slightly below the surface of the gypsum board in a dimple formed by the hammer or power screwdriver. Care should be taken to avoid breaking the face paper of the gypsum board. Improperly driven nails or screws should be removed.

Table 1

MINIMUM BENDING RADII FOR 1/4" HIGH FLEX GYPSUM BOARD

Application	Lengthwise		Widthwise	
	Bend Radii	Max. Stud Spacing	Bend Radii	Max. Stud Spacing
Inside (Concave) Dry	32"	9" o.c.	20"	9" o.c.
Outside (Convex) Dry	30"	9" o.c.	15"	8" o.c.
Inside (Concave) Wet	20"	9" o.c.	10"	6" o.c.
Outside (Convex) Wet	14"	6" o.c.	7"	5" o.c.

Lengthwise denotes long edges perpendicular to the framing members. Widthwise denotes long edges parallel to the framing members. The values listed in Table 1 were achieved at 65° F and 45% relative humidity. Lower temperatures and lower humidity will decrease the flexibility.

Wetting the board is only required on extremely tight radii, or when temperature and humidity conditions are lower than 65° F and 45% relative humidity. When wetting the board, apply 10-15 ounces of clean water per side with a paint roller or sprayer. Allow to soak 10-15 minutes before bending.



SPECIFICATIONS

THE FOLLOWING PARAGRAPHS ARE FOR INSERTION INTO SECTIONS OF GENERIC SPECIFICATIONS OR GENERIC/PROPRIETARY SPECIFICATIONS COVERING GYPSUM BOARD PRODUCTS. THE NATIONAL GYPSUM PRODUCT NAME FOLLOWS THE GENERIC DESCRIPTION IN PARENTHESES.

PART 2 PRODUCTS

2.01 MATERIALS

- A. Flexible Gypsum Board:
A gypsum core wall board with additives to enhance flexibility surfaced with paper on front, back and long edges and complying with ASTM C 1396. (High Flex BRAND Gypsum Board).
1. Thickness: 1/4"
 2. Width: 4'
 3. Length: 8' through 12'
 4. Edges: Slightly tapered

PART 3 EXECUTION

3.01 INSTALLATION

- A. General: In accordance with the manufacturer's recommendations, National Gypsum Company "*Gypsum Construction Guide.*"



DESCRIPTION

Gold Bond BRAND High Strength Ceiling Board is a specialty gypsum board with increased uniformity and integrity of its gypsum core, making its sag resistance equivalent to 5/8" type X gypsum board.

1/2" High Strength Ceiling Board is specifically designed for ceilings where framing members are spaced up to 24" o.c. and a water-based texture will be used.

1/2" High Strength Ceiling Board is available nationwide as a stocked item at all National Gypsum plants.

Excellent working characteristics, improved score and snap properties reduce the need for rasping.

Excellent sag resistance. Witnessed test results show overall sag on tested assembly to be equivalent to 5/8" type X gypsum board. Test report available upon request.

Eliminates need for two board sizes on the job. Scrap from ceiling is reduced since this material also can be used on the walls.

TECHNICAL DATA

In independent tests, High Strength Ceiling Board exhibited an average sag of only .033 (approx. 1/32") on joists spaced 24" on center with a spray texture applied. This test was conducted over one month at temperatures between 66°-79°F (19°C-26°C) and relative humidities between 30%-60%. (Reference: PSI report #722600-R71 March 25, 1991)

Under the strict ASTM C-473 Physical Testing for Humidified Deflection, Gold Bond BRAND 1/2" High Strength Ceiling Board exhibited sag-resistant properties equal to 5/8" type X gypsum board.

SURFACE BURNING CHARACTERISTICS

ASTM E 84

Flame spread index: 15

Smoke developed: 0

WEIGHT

1/2" Hi Strength - 1.8 lbs/SF

RECOMMENDATIONS

Installation of Gold Bond BRAND Gypsum Board should be consistent with methods described in, GA216, "Recommended Specifications for the Application of Gypsum Board," ASTM C 840, "Standard Specification for Application and Finishing of Gypsum Board."

Not recommended in areas of continuous high humidity such as saunas, steam rooms, gang shower rooms, and indoor pool enclosures. Prime with sealing latex primer and allow to dry thoroughly. Apply insulation and polyethylene vapor barrier (if used) before installing ceiling board. Insulation not to exceed 2.2 lbs./square foot (10.7 kg/m²). Adequate ventilation required.

1/2" High Strength Ceiling Board must be stored off the ground and under cover. Sufficient risers must be used to ensure support for the entire length of the gypsum board to prevent sagging.

Not to be exposed to temperatures exceeding 125°F (52°C) for extended periods of time.

Installing gypsum board over an insulating blanket, installed continuously across the face of the framing members, is not recommended. Blankets should be recessed and flanges attached to the sides of the studs or joists.

DECORATION

For best painting results, all surfaces, including joint compound, should be clean, dust-free and not glossy. To improve fastener and joint concealment, a coat of a quality primer is recommended to equalize the porosities between surface paper and joint compound. Drywall primer is a product specially formulated for this purpose.

The selection of a paint to give the specified or desired finished characteristics is the responsibility of the architect or contractor.

Gypsum board that is to have a wallcovering applied to it should be prepared and primed as described for painting.



Gypsum Association GA-214, Recommended Specification for Levels of Gypsum Board Finish, should be referred to in order to determine the level of finishing needed to ensure a surface properly prepared to accept the desired decoration.

SS-L-30D type III, Grade R, Class 1. (Gold Bond BRAND High Strength Ceiling Board).

1. Thickness: 1/2"

2. Width: 4'

3. Length: 6' through 16'

4. Edge: Tapered

SPECIFICATIONS

THE FOLLOWING PARAGRAPHS ARE FOR INSERTION INTO SECTIONS OF GENERIC SPECIFICATIONS OR GENERIC/PROPRIETARY SPECIFICATIONS COVERING GYPSUM BOARD PRODUCTS. THE NATIONAL GYPSUM PRODUCT NAME FOLLOWS THE GENERIC DESCRIPTION IN PARENTHESES.

PART 2 PRODUCTS

2.01 MATERIALS

- A. Gypsum Ceiling Board: A gypsum core ceiling board with additives to enhance the sag resistance of the core and surfaced with paper on front, back, and long edges, complying with ASTM C 1396 and Federal specification

PART 3 EXECUTION

3.01 INSTALLATION

- A. General: In accordance with the manufacturer's recommendations, National Gypsum Company "Gypsum Construction Guide."

Gold Bond® BRAND Hi-Abuse XP® Gypsum Board

DESCRIPTION

Gold Bond® BRAND Hi-Abuse XP® Gypsum Board panels consist of a mold and fire resistant type x gypsum core encased in heavy mooth abrasion resistant, moisture, mold/mildew-resistant, 100% recycled purple paper on the face side and heavy mold/mildew-resistant liner paper on the back side. Hi-Abuse XP Gypsum Board is designed to provide extra protection against mold and mildew compared to standard gypsum board products. The panels feature a specifically formulated core to provide greater resistance to surface indentation and impact than fiber-reinforced gypsum panels. Long edges of the panels are tapered. Tapered edges allow joints to be treated in the normal manner. For optimum mold and mildew resistance, National Gypsum recommends ProForm BRAND XP Ready Mix, or Sta-Smooth/Sta-Smooth Lite setting compounds.

TECHNICAL DATA

Surface Abrasion Test ASTM – D 4977 (Modified)		
	5/8" Hi-Abuse XP	5/8" Gypsum Board Type X
Mean Depth Abrasion	0.009 in.	0.576 in.
Performance Classification	Level 3	Does Not Qualify

Procedure Summary – A sample is laid flat and subjected to 50 abrasion cycles of a wire brush with additional 25 lbs. weight. The depth of abrasion in three consecutive samples is measured and reported as a mean depth of abrasion in inches. This test measures the ability of a panel to withstand surface scuffs and abrasions.

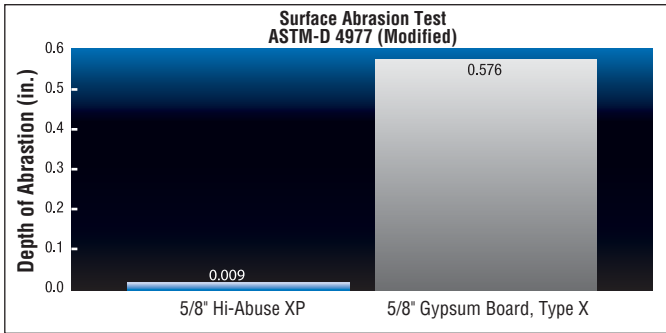

Walls and ceilings in school corridors and cafeterias are ideal applications for Gold Bond® BRAND Hi-Abuse XP® Gypsum Board.

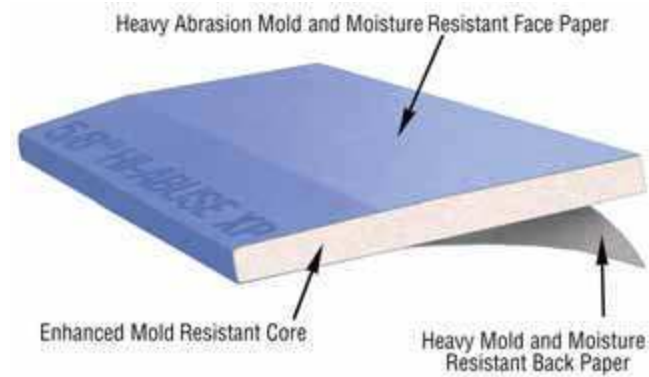

Single Drop Soft Body Impact Test Modified ASTM – E 695 (Modified)		
	5/8" Hi-Abuse XP	5/8" Gypsum Board Type X
Ft.-Lbs. required to penetrate	210	120
Performance Classification	Level 2	Level 1

Procedure Summary – This test is conducted with a leather bag loaded with steel pellets to a weight of 60 lbs. The bag is suspended by a rope and dropped at an angular distance until specimen is impacted.

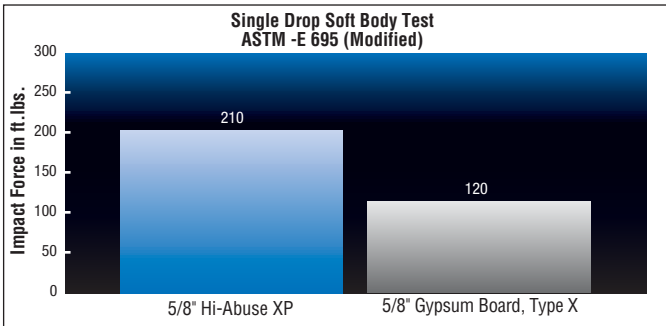

Surface Indentation Resistance Modified ASTM – D 5420 (Gardner Impact)		
	5/8" Hi-Abuse XP	5/8" Gypsum Board Type X
Mean Depth of indentation	0.132 in.	0.230 in.
Performance Classification	Level 1	Does Not Qualify

Procedure Summary – A sample is laid flat and impacted by a 5/8" hemispherical rod raised to height that provides 72 in.-lbs. of impact energy. The depth of the indentation is measured from three board samples and reported as a mean depth of indentation in inches. This test measures the ability for a panel to resist dents.

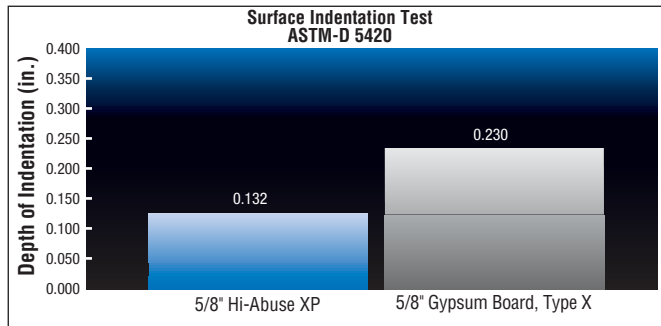

SURFACE BURNING CHARACTERISTICS

ASTM E 84
Flame spread (Face): 15
Smoke developed: 0

WEIGHT

1/2" Hi-Abuse XP - 2.4 lbs/SF
5/8" Type X Hi-Abuse - 2.8 lbs/SF

FIRE RESISTANCE RATINGS

Fire resistance ratings represent the results of tests on assemblies made up of specific materials in a specific configuration. When selecting construction designs to meet certain fire resistance requirements, caution must be used to ensure that each component of the assembly is the one specified in the test. Further, precaution should be taken that assembly procedures are in accordance with those of the tested assembly. (For copies of specific tests, call 1-800-NATIONAL.)

MOLD AND MILDEW RESISTANCE

Hi-Abuse® BRAND XP Gypsum Board has been designed to provide extra protection against mold and mildew compared to standard gypsum board products. When tested by an independent lab per ASTM D3273 ("Standard Test Method for Resistance to Growth of Mold On the Surface of Interior Coatings in an Environmental Chamber"), Hi-Abuse XP Gypsum Board achieved a score of 10, the best possible score for this test.

The use of Hi-Abuse XP Gypsum Board in actual installations may not produce the same results as were achieved in controlled, laboratory conditions. No material can be considered "mold proof," nor is it certain any material will resist mold or mildew indefinitely. When used in conjunction with good design, handling and construction practices, Hi-Abuse XP Gypsum Board can provide increased mold resistance versus standard gypsum board products. As with any building material, avoiding water exposure during handling, storage and installation, and after installation is complete, is the best way to avoid the formation of mold or mildew.

RECOMMENDATIONS

Installation of Hi-Abuse XP Gypsum Board should be consistent with methods described in the standards references noted. For best performance, use vertical application.

GridMarX®

Hi-Abuse® BRAND XP Gypsum Board comes standard with GridMarX® guide marks printed on the paper surface. These guide marks align with standard building dimensions and help to quickly identify fastener lines for stud and joist framing. Using GridMarX, accurate cuts can be made without having to draw lines. The use of GridMarX also provides quick identification and uniform nail/screw patterns.

GridMarX guide marks run the machine direction of the board at five points in 4" increments. Marks run along the edge in both tapers and at 16", 24" and 32" in the field of the board. The marks cover easily with no bleed-through using standard products.

Vertical Application - In a vertical application, GridMarX serves as a **guide mark** to help identify the exact location of framing members behind the gypsum board, eliminating the need for field-applied vertical lines.

Horizontal Application - In a horizontal application, GridMarX serves as a **reference mark** to help identify the location of framing members behind the gypsum board. (If framing member is located 2" to the right of the GridMarX at the top edge of the board, it will be located 2" to the right down the face of the board.)

Provides greater resistance to surface abuse, indentation and impact than fiber-reinforced gypsum panels.

Hi-Abuse XP smooth face paper is highly resistant to scuffing when sanding gypsum board joints and fasteners providing a superior surface for decoration.

Hi-Abuse XP Gypsum Board is easily scored and snapped for quick installation. Openings and outlet boxes are cut out in same manner as regular gypsum board.

Minimum bending radii for 5/8" Hi-Abuse XP Gypsum Board is 20'-0" applied lengthwise perpendicular to framing spaced not greater than 12" on center.

Lightweight, cost-efficient material that readily accepts a wide range of decorative finishes.

The gypsum core will not support combustion or transmit temperatures greatly in excess of 212°F (100°C) until completely calcined, a slow process.

Expansion and contraction under normal atmospheric changes are negligible.

Hi-Abuse XP 5/8" Fire-Shield panels may be used where Type X gypsum panels are specified in fire-rated wall and floor-ceiling assemblies (i.e. UL, U300, U400, V400 and L500 series.)

Exposure to excessive or continuous moisture and extreme temperatures should be avoided. Hi-Abuse XP Gypsum Board is not recommended where it will be exposed to temperatures exceeding 125°F (52°C) for extended periods of time.

Hi-Abuse XP Gypsum Board shall not be used where there will be direct exposure to water or continuous high humidity conditions, such as found in tub and shower enclosures, saunas, steam rooms and gang showers. If the area is to be exposed to water or continuous high humidity, National Gypsum's PermaBase® BRAND Cement Board should be used.

Hi-Abuse XP Gypsum Board must be stored off the ground and under cover. Sufficient risers must be used to ensure support for the entire length of the gypsum board to prevent sagging.

Hi-Abuse XP Gypsum Board must be kept dry to minimize the potential for mold growth. Adequate care should be taken while transporting, storing, applying and maintaining gypsum board. For additional information, refer to the Gypsum Association publication, "Guidelines for the Prevention of Mold Growth on Gypsum Board" (GA-238-03), which is available at www.gypsum.org under the "Download Free Gypsum Association Publications" section.

DECORATION

For best painting results, all surfaces, including joint compound, should be clean, dust-free and not glossy. To improve fastener and joint concealment, a coat of a quality drywall primer is recommended to equalize the porosities between surface and joint compound.

The selection of a paint to give the specified or desired finished characteristics is the responsibility of the architect or contractor.

Hi-Abuse XP Gypsum Board that is to have a wall covering applied to it should be prepared and primed as described for painting.

Gypsum Association GA-214, "Recommended Specifications for Levels of Gypsum Board Finish," should be referred to in order to determine the level of finishing needed to ensure a surface properly prepared to accept the desired decoration.

SPECIFICATIONS

THE FOLLOWING PARAGRAPHS ARE FOR INSERTIONS INTO SECTIONS OF GENERIC SPECIFICATIONS OR GENERIC/PROPRIETARY SPECIFICATIONS COVERING GYPSUM BOARD PRODUCTS. THE NATIONAL GYPSUM PRODUCT NAME FOLLOWS THE GENERIC DESCRIPTION IN PARENTHESES.

PART 2 PRODUCTS

2.01 MATERIALS

A. Fire, Abuse and Mold Resistant Gypsum Board: A gypsum core wall panel with additives to enhance fire resistance, surface indentation resistance and impact resistance of the core and surfaced with abrasion, moisture/mold/mildew resistant paper on front, back and long edges; and complying with ASTM C 1396 Type X (Hi-Abuse BRAND XP Fire-Shield Gypsum Board).

1. Thickness: 5/8"
2. Width: 4'
3. Length: 8' through 12'
4. Edges: Tapered
5. Surface Abrasion Resistance: Not greater than 0.009 depth when tested at 50 cycles in accordance with ASTM D 4977, modified.
6. Indentation Resistance: Not greater than 0.132" depth when tested at an impact load of 72 in.-lbs. In accordance with ASTM D 5420.
7. Impact/Penetration Resistance: Not less than 210 ft.-lbs. required to penetrate when tested in accordance with ASTM E 695, modified.
8. Mold/Mildew Resistance: Panel score of 10 when tested in accordance with ASTM D 3273.

PART 3 EXECUTION

3.01 INSTALLATION

A. General: In accordance with the manufacturer's recommendations, National Gypsum Company "Gypsum Construction Guide."

DESCRIPTION

Gold Bond® BRAND Hi-Impact XP® Gypsum Board panels consist of a mold, moisture and fire resistant type X gypsum core encased in heavy, smooth, abrasion-resistant, mold/mildew-resistant, 100% recycled purple paper on the face side and heavy mold/mildew resistant liner paper on the back side. A fiberglass mesh is embedded in the core, close to the back of the board to provide additional impact/penetration resistance. Hi-Impact XP Gypsum Board features a specially formulated core to provide fire resistance ratings when used in tested systems in addition to providing extra protection against mold and mildew compared to standard gypsum board products. Long edges of panels are tapered. Tapered edges allow joints to be treated in the normal manner. For optimum mold and mildew resistance, National Gypsum recommends ProForm BRAND XP Ready Mix, or Sta-Smooth/Sta-Smooth Lite compounds.

TECHNICAL DATA

Surface Abrasion ASTM – D 4977 (Modified)		
	5/8" Hi-Impact XP with Fiberglass Scrim	5/8" Gypsum Board Type X
Mean Depth Abrasion	0.009 in.	0.576 in.
Performance Classification	Level 3	Does Not Qualify
Procedure Summary – A sample is laid flat and subjected to 50 abrasion cycles of a wire brush with additional 25 lbs. weight. The depth of abrasion in three consecutive samples is measured and reported as a mean depth of abrasion in inches. This test measures the ability of a panel to withstand surface scuffs and abrasions.		

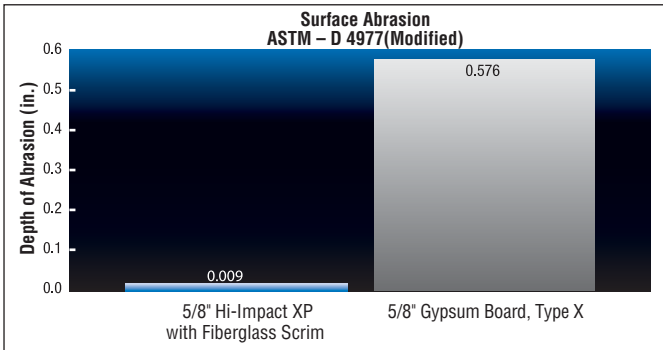

Single Drop Soft Body Impact Test ASTM – E 695 (Modified)		
	5/8" Hi-Impact XP with Fiberglass Scrim	5/8" Gypsum Board Type X
Ft.-lbs. required to penetrate	>540*	120
Performance Classification	Level 3	Level 1
Procedure Summary – This test is conducted with a leather bag loaded with steel pellets to a weight of 120 lbs. The bag is suspended by a rope and dropped at an angular distance until specimen is impacted.* In the test the framing collapsed without failure to the Hi-Impact panels.		

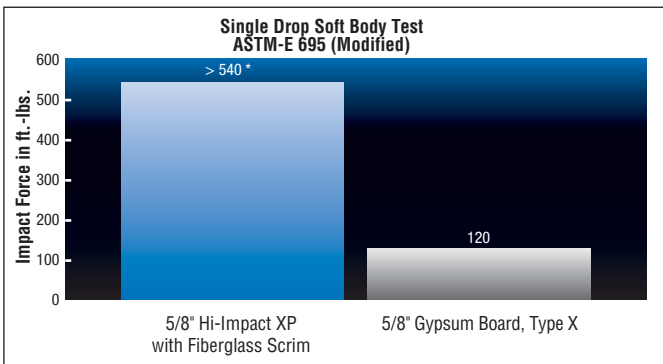

Prison walls have to be strong. And, with GOLD BOND® BRAND Hi-Impact XP® Gypsum Board, strong walls can be installed as easily as regular gypsum board.

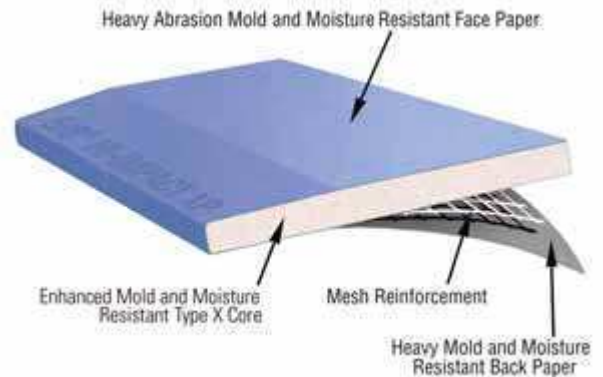

Surface Indentation Test ASTM – D 5420 (Gardner Impact)		
	5/8" Hi-Impact XP with Fiberglass Scrim	5/8" Gypsum Board Type X
Mean Depth of indentation	0.114 in.	0.230 in.
Performance Classification	Level 1	Does Not Qualify
Procedure Summary – A sample is laid flat and impacted by a 5/8" hemispherical rod raised to height that provides 72 in.-lbs. of impact energy. The depth of the indentation is measured from three board samples and reported as a mean depth of indentation in inches. This test measures the ability for a panel to resist dents.		

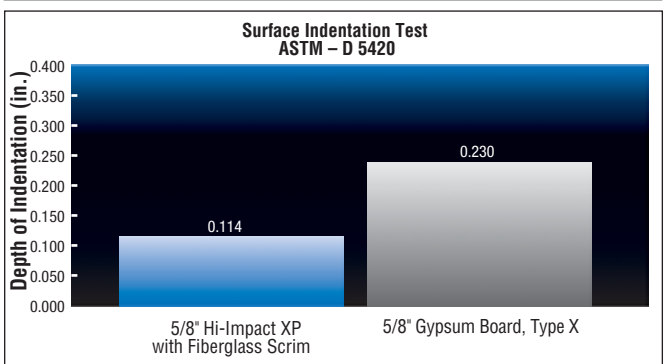

09 29 00

Hard Body Impact - ASTM C 1629		
	5/8" Hi-Impact XP with Fiberglass S scrim	5/8" Gypsum Board Type X
Ft.-lbs. to penetrate into cavity	>160	35
Performance Classification	Level 3	Does Not Qualify
Procedure Summary – A 2' x 2' board sample is mounted to a 3-5/8", 20 gauge steel frame and runners using drywall screws. The sample is impacted with a ram mounted on a pendulum which is faced with a 2-3/4" steel cylinder dropped from a fixed height. Weights are added to increase the impacting energy. The maximum impact force that the sample can withstand without penetration through the sample and into the stud cavity is reported in foot-pounds. This test measures the ability to withstand the impact of a hard object such as a hammer or heel of a boot.		

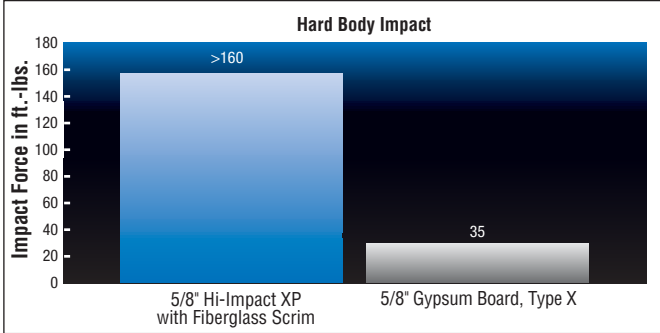

Water Absorption ASTM C 473		
	5/8" High-Impact XP with Fiberglass S scrim	5/8" Gypsum Board Type X
Percentage of Weight Gained	4%	47%
Procedure Summary – Three dry board samples were cut and weighed. Each sample was then submerged in a 3-inch water bath for two hours. The samples were removed, wiped and weighed again. The weight gained is calculated and reported as a percentage. The higher the percentage the more water the panel absorbed.		

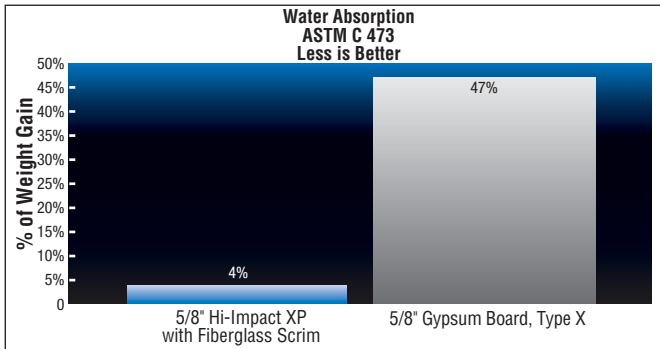

SURFACE BURNING CHARACTERISTICS

ASTM E 84 (Face)
 Flame spread: 15
 Smoke developed: 0

WEIGHT

5/8" Hi-Impact XP - 2.8 lbs/5F

MOLD AND MILDEW RESISTANCE

Hi-Impact® XP Gypsum Board has been designed to provide extra protection against mold and mildew compared to standard gypsum board products. When tested by an independent lab per ASTM D3273 ("Standard Test Method for Resistance to Growth of Mold On the Surface of Interior Coatings in an Environmental Chamber"), Hi-Impact XP Gypsum Board achieved a score of 10, the best possible score for this test.

The use of Hi-Impact XP Gypsum Board in actual installations may not produce the same results as were achieved in controlled,

laboratory conditions. No material can be considered "mold proof," nor is it certain any material will resist mold or mildew indefinitely. When used in conjunction with good design, handling and construction practices, Hi-Impact XP Gypsum Board can provide increased mold resistance versus standard gypsum board products. As with any building material, avoiding water exposure during handling, storage and installation, and after installation is complete, is the best way to avoid the formation of mold or mildew.

FIRE RESISTANCE RATINGS

Fire resistance ratings represent the results of tests on assemblies made up of specific configuration. When selecting construction designs to meet certain fire resistance requirements, caution must be used to ensure that each component of the assembly is the one

specified in the test. Further precaution should be taken specified in the test. Further precaution should be taken that assembly procedures are in accordance with those of the tested assembly. (For copies of specific tests, call 1-800-NATIONAL.)

FIRE ENDURANCE

- 1-Hour Rating: Hi-Impact XP Gypsum Board screw attached vertically to both sides of 20 gauge 3-5/8" studs spaced 16" o.c. with 1-1/4" long, type S screws spaced 8" o.c. along edges and 12" o.c. in the field of the board. Gypsum board joints staggered. UL U465
- 2-Hour Rating: Constructed with a base layer of Hi-Impact XP Gypsum Board with an additional layer of 5/8" Fire-Shield Gypsum Board Type X screw attached vertically to both sides of 20 gauge 3-5/8" studs spaced 16" o.c. with joints staggered between face and base layer. Base layer attached with 1-1/4" long type S screws spaced 8" o.c. along edges and 12" o.c. in the field of the board. Outer layer attached with 2-1/2" long type S screws spaced 8" o.c. in the field and along vertical edges and to the floor and ceiling runners. UL U411

For additional UL Design Listings, please reference the UL Directory.

RECOMMENDATIONS

Installation of 5/8" Hi-Impact XP Fire-Shield Type X Gypsum Board should be consistent with methods described in Applicable Standards with one exception - for best results, cutting and scoring of Hi-Impact XP should be from the back side of the board.

GridMarX®

Hi-Impact XP Gypsum Board comes standard with GridMarX® guide marks printed on the paper surface. These guide marks align with standard building dimensions and help to quickly identify fastener lines for stud and joist framing. Using GridMarX, accurate cuts can be made without having to draw lines. The use of GridMarX also provides quick identification and uniform nail/screw patterns.

GridMarX guide marks run the machine direction of the board at five points in 4" increments. Marks run along the edge in both tapers and at 16", 24" and 32" in the field of the board. The marks

at 16", 24" and 32" in the field of the board. The marks cover easily with no bleed-through using standard products.

Vertical Application - In a vertical application, GridMarX serves as a **guide mark** to help identify the exact location of framing members behind the gypsum board, eliminating the need for field-applied vertical lines.

Horizontal Application - In a horizontal application, GridMarX serves as a **reference mark** to help identify the location of framing members behind the gypsum board. (If framing member is located 2" to the right of the GridMarX at the top edge of the board, it will be located 2" to the right down the face of the board.)

Hi-Impact XP Gypsum Board can be used as a tile backer board in dry areas and areas with limited water exposures such as toilet/sink areas and areas above tile in tubs and showers

Hi-Impact XP Gypsum Board should not be used as a backer board directly behind tile in tub and shower areas.

Hi-Impact XP should not be used in areas subject to constant and/or excessive moisture and high humidity such as gang showers, saunas, steam rooms and swimming pool enclosures. PermaBase BRAND cement board is recommended for these areas.

Hi-Impact XP Gypsum Board can be used on the interior side of exterior walls in hot, humid climates such as the Southern Atlantic and Gulf Coast areas.

Hi-Impact XP Gypsum Board features a type X core to provide additional fire resistance when used in tested systems.

Hi-Impact XP Gypsum Board is easily cut for quick installation, permitting painting or other decoration and the installation of most metal or wood trim almost immediately.

Minimum bending radii for 5/8" Hi-Impact XP Gypsum Board is 20'-0" applied lengthwise perpendicular to framing spaced not greater than 12" on center.

The gypsum core will not support combustion or transmit temperatures greatly in excess of 212°F (100°C) until completely calcined, a slow process.

Exposure to excessive or continuous moisture and extreme temperatures should be avoided.

Listed impact/penetration ratings apply to walls constructed with Hi-Impact XP Gypsum Board applied with long edges parallel to and centered over minimum 20 gauge framing members spaced a maximum of 16" o.c.

Hi-Impact XP Gypsum Board must be stored off the ground and under cover. Sufficient risers must be used to ensure support for the entire length of the gypsum board to prevent sagging.

Hi-Impact XP Gypsum Board must be kept dry to minimize the potential for mold growth. Adequate care should be taken while transporting, storing, applying and maintaining gypsum board. For additional information, refer to the Gypsum Association publication, "Guidelines for the Prevention of Mold Growth on Gypsum Board" (GA-238-03), which is available at www.gypsum.org under the "Download Free Gypsum Association Publications" section.

DECORATION

For best painting results, all surfaces, including joint compound, should be clean, dust-free and not glossy. To improve fastener and joint concealment, a coat of high quality latex primer is recommended to equalize the absorption between surface paper and joint compound. Drywall primer is specially formulated for this purpose.

The selection of a paint to give the specified or desired finished characteristics is the responsibility of the architect or contractor.

Hi-Impact XP Gypsum Board that is to have a wall covering applied to it should be prepared and primed as described for painting.

Gypsum Association GA-214, "Recommended Specification for Levels of Gypsum Board Finish," should be referred to in order to determine the level of finishing needed to ensure a surface properly prepared to accept the desired decoration.

SPECIFICATIONS

THE FOLLOWING PARAGRAPHS ARE FOR INSERTION INTO SECTIONS OF GENERIC SPECIFICATIONS FOR GENERIC/PROPRIETARY SPECIFICATIONS COVERING GYPSUM BOARD PRODUCTS. THE NATIONAL GYPSUM PRODUCT NAME FOLLOWS THE GENERIC DESCRIPTION IN PARENTHESES.

PART 2 PRODUCTS

2.01 MATERIALS

A. Fire, Impact/Penetration and Mold-Resistant Gypsum Board: A gypsum core wall panel with additives to enhance the fire and resistance, and mold/mildew resistance of the core; surfaced with abrasion/moisture/mold/mildew resistant paper on the front, back and long edges with a fiberglass mesh embedded in the board to enhance impact/penetration resistance and complying with ASTM C 1396, Type X. (Gold Bond BRAND Hi-Impact XP Fire-Shield Gypsum Board).

1. Thickness: 5/8"
2. Width: 4'
3. Length: 8' through 12'
4. Edges: Tapered

5. Surface Abrasion Resistance: Not greater than 0.009" depth when tested at 50 cycles in accordance with ASTM D 4977, Modified.
6. Indentation Resistance: Not greater than 0.114" depth when tested at an impact load of 72 in.-lbs. in accordance with ASTM D 5420.
7. Impact/Penetration Resistance: Not less than 720 ft.-lbs. required to penetrate when tested in accordance with ASTM E 695, Modified.
8. Mold/Mildew Resistance: Panel score of 10 when tested in accordance with ASTM D 3273.

PART 3 EXECUTION

3.01 INSTALLATION

- A. General: In accordance with the manufacturer's recommendations, National Gypsum Company "Gypsum Construction Guide."

GOLD BOND® BRAND SoundBreak™ Gypsum Board

DESCRIPTION

Gold Bond® BRAND SoundBreak™ Gypsum Board is an acoustically enhanced gypsum board used in the construction of high rated STC wall assemblies. This 5/8" thick gypsum board consists of a layer of viscoelastic damping polymer sandwiched between two pieces of enhanced high density mold resistant gypsum board, providing constrained layer damping.

For speed of installations, GridMarX® guide marks are printed on the paper surface.

Long edges of the panels are tapered. Tapered edges allow joints to be reinforced with ProForm® BRAND Joint Tape and concealed with ProForm® BRAND Ready Mix, Easy Finish® BRAND Ready Mix or ProForm® BRAND Sta-Smooth® Joint Compounds. For optimum mold and mildew performance, National Gypsum recommends ProForm® BRAND XP® Ready Mix.

Use of SoundBreak Gypsum Board results in wall partitions with high rated STC values that are thinner than traditionally built high rated STC wall partitions, providing increased usable floor space.

Superior sound damping, cost-efficient material that is easily finished and decorated in the same manner as regular gypsum board.

All SoundBreak Gypsum Board designs were tested by an independent third-party acoustical laboratory using the full scale ASTM E90 test procedure.

SoundBreak Gypsum Board is installed like traditional gypsum board offering a more reliable and less complicated solution than alternative methods requiring clips and/or channels.

SoundBreak Gypsum Board can be cut by scoring deeply from both sides of the board before snapping, or with the use of a hand or reciprocating saw.

TECHNICAL DATA

SURFACE BURNING CHARACTERISTICS

ASTM E 84
Flame spread: 15
Smoke developed: 0

WEIGHT

SoundBreak - 2.7 lbs/SF

FIRE RESISTANCE RATINGS

As an option, SoundBreak Gypsum Board may be used as an additional layer on one or both sides of fire-rated wall assemblies (i.e., U300, W300, U400, W400 and V400 series designs). SoundBreak Gypsum Board cannot be used as a substitute for 5/8" Type X gypsum board in a fire-related assembly.

SoundBreak Gypsum Board shall be attached in accordance with manufacturer's recommendations. When SoundBreak Gypsum Board is installed between the framing and the UL/ULC Classified gypsum board, the UL/ULC Classified gypsum board layer(s) required for the design is/are to be installed as indicated in the design as to fastener type and spacing, except that the required fastener length shall be increased by a minimum of 5/8" (16 mm).

For U300, W300, U400, W400 and V400 series designs, outer layer treated with joint compound and paper tape as specified in the design.

For additional information go to *UL/ULC Online Certifications Directories, Product Category Code CLB.V.R25426 – Wall and Partition Facings and Accessories.*

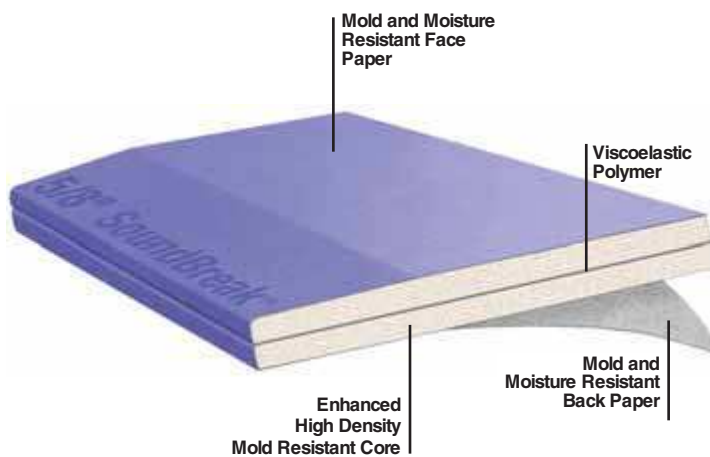

For additional information go to www.SoundBreak.info.

**MOLD AND MILDEW RESISTANCE

SoundBreak Gypsum Board was designed to provide extra protection against mold and mildew compared to standard gypsum board products.

When tested by an independent lab per ASTM D3273 ("Standard Test Method for Resistance to Growth of Mold on the Surface of Interior Coatings in an Environmental Chamber"), SoundBreak Gypsum Board achieved a score of 10, the best possible score for this test.

RECOMMENDATIONS

- Installation of SoundBreak Gypsum Board should be consistent with methods described in the standards and references noted.
- Stagger SoundBreak Gypsum Board joints from one side of the wall to another.
- Allow a 1/4" gap along all perimeter edges and completely seal 1/4" gap with acoustical sealant or caulk.
- Refrain from wall penetrations when possible.
- Limit necessary wall penetrations to one per stud cavity.
- Seal all penetrations with acoustical sealant and/or putty pads.
- The use of SoundBreak Gypsum Board in actual installations may not produce the same results as were achieved in controlled, laboratory conditions.
- Use an acoustical sealant that is applied per ASTM C919, such as Grabber Acoustical Sealant GSC, STI SpecSeal Smoke N Sound Caulk, BOSS 824 Acoustical Sound Sealant or equivalent.
- Use a putty pad that has been tested per ASTM E90, such as STI SpecSeal SSP Putty Pads or BOSS 818 Fire-Rated Putty Pads or equivalent.
- Exposure to excessive or continuous moisture and extreme temperatures should be avoided. SoundBreak Gypsum Board is not recommended where it will be exposed to temperatures exceeding 125° (52°C) for extended periods of time.
- SoundBreak Gypsum Board is for use in wall assemblies.
- Installing SoundBreak Gypsum Board panels over an insulating blanket, installed continuously across the face of the framing members, is not recommended. Blankets should be recessed and flanges attached to the sides of the studs.

SoundBreak Gypsum Board must be stored off the ground and under cover. Sufficient risers must be used to ensure support for the entire length of the gypsum board to prevent sagging.

SoundBreak Gypsum Board must be kept dry to minimize the potential for mold growth. Adequate care should be taken while transporting, storing, applying and maintaining SoundBreak Gypsum Board. For additional information, refer to the Gypsum Association publication, "Guidelines for the Prevention of Mold Growth on Gypsum Board" (GA-238-03), which is available at www.gypsum.org under the "Download Free Gypsum Association Publications" section.

DECORATION

For best painting results, all surfaces, including joint compound, should be clean, dust-free and not glossy. To improve fastener and joint concealment, a coat of quality drywall primer is recommended to equalize the porosities between surface paper and joint compound.

The selection of a paint to give the specified or desired finished characteristics is the responsibility of the architect or contractor.

SoundBreak Gypsum Board that is to have a wall covering applied should be prepared and primed as described for painting.

Gypsum Association GA-214, *Recommended Specification for Levels of Gypsum Board Finish*, should be referred to in order to determine the level of finishing required to ensure a properly prepared surface that accepts the desired decoration.

SPECIFICATIONS

PART 2 PRODUCTS

THE FOLLOWING PARAGRAPHS ARE FOR INSERTION INTO SECTIONS OF GENERIC SPECIFICATIONS OR GENERIC/PROPRIETARY SPECIFICATIONS COVERING GYPSUM BOARD PRODUCTS. THE NATIONAL GYPSUM PRODUCT NAME FOLLOWS THE GENERIC DESCRIPTION IN PARENTHESES.

2.01 MATERIALS

- A. Acoustically Enhanced Mold and Mildew Resistant Gypsum Board: A gypsum core wall panel with a constrained viscoelastic polymer center layer; surfaced with moisture/mold/mildew resistant paper on front, back and long edges and complying with ASTM C 1396 (Gold Bond® BRAND SoundBreak Gypsum Board)

1. Thickness: 5/8"
2. Width: 4'
3. Length: 8', 9', 10' or 12'
4. Edges: Tapered
5. Mold and Mildew Resistance: Panel Score of 10 when tested in Accordance with ASTM D 3273

PART 3 EXECUTION

3.01 INSTALLATION

- A. General: In accordance with the manufacturer's recommendations, National Gypsum Company "Gypsum Construction Guide."

Gridstone® BRAND Ceiling Panels

DESCRIPTION

Gridstone® BRAND prefinished ceiling panels have a non-combustible, Fire-Shield G gypsum core. The 2-mil white, stipple-textured vinyl laminate combines high light reflectance with easy cleanability.

Gridstone panels can be used for interior and exterior ceiling applications.

Gridstone Ceiling Panels install easily in standard 2' x 2' and 2' x 4' exposed grid systems. Ceiling panels have a rigid gypsum core which provides extra resistance to sagging and warping.

A noncombustible gypsum core ensures fire safety with 1 1/2- and 2-hour fire rating achievable depending on installation.

The sturdy white vinyl laminate eliminates additional finishing.

As little as 1" of material can be cut from Gridstone panels with practically none of the crumbling common with mineral fiber panels.

For exterior application, protect grid panels from direct exposure to weather, water and continuous high humidity. Under no circumstances should water be in contact with the back of the panels.

Overlaid insulation may cause excessive panel deflection and is not recommended where high humidity is likely to occur.

Extreme lighting conditions may distort texture appearance.

The use of strong organic solvents (such as ketones), harsh abrasive cleansers or steel wool are not recommended. These materials may cause dulling, discoloration, softening and other permanent damage to the vinyl surface.

USDA Acceptance: Gridstone panels are accepted by the USDA for use in food service and food processing areas.

TECHNICAL DATA

A. Specification Compliance

Gridstone panels conform to ASTM C 1396 Type X Class I.

B. Light Reflectance

LRI (75% or greater)

C. Sound Attenuation

(Per ASTM E1414)

Type	Thickness	Construction	CAC	NGC Report #
Gridstone	1/2" FSW-G (12.7 mm)	Continuous	46dB	6098001

D. Abrasion

Wet: (Gardner Scrub Tester) 2000 oscillations with no film break-through and only minor erosions.

Dry: (Taber Abrasion Test with CS-17 Wheel) 500 cycles with no break-through to the substrate.

E. Surface Burning Characteristics

(Per ASTM E 84)

Type	Flame Spread	Smoke Developed	Class	Test
Gridstone	5	0	A	WHI 694-0700.7

F. Weight

1/2" FSW-G - 2.18 lbs/SF

G. Fire Rating

(Per ASTM E 119)

Type	Thickness	Nominal Size	Design*	Rating
Gridstone	1/2" FSW-G (12.7 mm)	2' x 2' (610 mm x 610 mm)	UL G222 FM FC-299	2 hr.
		2' x 4' (610 mm x 1219 mm)	UL G259 FM FC-300	1 1/2 hr.

*See Quick Selector, page 25, for fire rated assembly details.



RECOMMENDATIONS

Gridstone ceiling panels are designed to be mounted in standard 15/16" exposed tee grid systems or environmental type grids for severe conditions, with grids either 2' x 2' or 2' x 4'. Grid installation should be conducted according to manufacturer's specification.

Each panel must be supported on all four (4) edges.

Cross ventilation must be provided in unheated or enclosed space above ceiling panels.

General: Install panels in lay-in suspension systems with edges concealed by flanges of suspension members. Cut boards to fit tightly at borders and penetrations so that cut edges are concealed by trim pieces and escutcheons.

Cleaning: Common dirt and stains on the vinyl surface can be removed with mild soap or detergent in lukewarm water. Use a light, scrubbing action with a cloth, sponge or soft brush.

If the suitability of any cleaning agent is unknown, check its effect on the Gridstone panel surface in a hidden area or on a scrap piece before attempting to remove a field stain.

Gridstone Ceiling Panels are not recommended for use in areas exposed to extreme or continuous moisture such as found in saunas, steam rooms, gang shower rooms or indoor pool enclosures, per ASTM C840 17.3.1.1.

DECORATION

Gridstone Brand Ceiling Panels are factory-finished decorative products which do not require painting. However, if desired, Gridstone can be painted with the following two products:

1. Two coats of an alkyd or latex enamel.
2. Oil primer with finish coat of oil or latex paint.
3. Two coats of latex paint.

Vinyl laminate on face of 2' x 2' Gridstone panel is directional. Install with all factory edges parallel (same direction).



GRIDSTONE® BRAND CLEANROOM CEILING PANELS

DESCRIPTION

Gridstone BRAND CleanRoom Ceiling Panels are sealed on the face, back and long edges with a 2 mil rigid vinyl film. The exposed edges are factory sealed with a durable coating providing a completely sealed panel.

Gridstone CleanRoom panels are for use in systems designed for areas requiring high levels of air cleanliness for airborne particulate levels such as clean rooms and clean zones.

Designed for clean room use. Approved for use in systems, Class 100,000, Class 10,000, Class 1,000, Class 100 per Federal Standard 209E "Airborne Particulate Cleanliness Classes in Clean Rooms and Clean Zones."

Fire-resistant. A non-combustible gypsum core ensures fire safety with 1 1/2 and 2-hour fire rating achievable depending on installation.

Sag-resistant. Gridstone CleanRoom panels' rigid gypsum core prevents sagging and warping problems and is backed by a 15-year limited warranty.

Do not install panels in areas exposed to continuous high humidity such as saunas, steam rooms, gang showers, and indoor pools per ASTM C840, 17.3.1.1.

Overlaid insulation may cause excessive panels deflection and is not recommended where high humidity is likely to occur.

Extreme lighting conditions may distort texture appearance.

The use of strong organic solvents (such as ketones), harsh abrasive cleansers or steel wool are not recommended.

These materials may cause dulling, discoloration, softening and other permanent damage to the vinyl surface.

Gridstone CleanRoom panels are USDA accepted for use in food service and food processing areas.

TECHNICAL DATA

Reference Gridstone technical data on page 86.

RECOMMENDATIONS

Gridstone CleanRoom Ceiling Panels are designed to be used in a gasket seal suspended grid system using hold down clips.

Recommended use of Gordon DS-20 gasket Seal System or equivalent gasket sealed grid systems designed for clean room applications. Grid installation should be conducted according to manufacturer's specification.

Each panel must be supported on all four (4) edges.

Cross ventilation must be provided in unheated or enclosed space above ceiling panels.

General: Install panels in lay-in suspension systems with edges concealed by flanges of suspension members. Cut panels to fit tightly at borders and penetrations so that cut edges are concealed by trim pieces and escutcheons.

If panel cuts are required, exposed core should be sealed to maintain performance of the system.

Cleaning: Common dirt and stains on the vinyl surface can be removed with mild soap or detergent in lukewarm water. Use a light scrubbing action with a cloth, sponge or soft brush.

If the suitability of any cleaning agent is unknown, check its effect on the Gridstone CleanRoom panel surface in a hidden area or on a scrap piece before attempting to remove a field stain.

Vinyl laminate on face of 2' x 2' Gridstone CleanRoom panel is directional. Install with all factory edges parallel (same direction).

PACKAGING

2' x 2' – 4 pcs./bundle, 16 sq. ft., 80 bundles/Unit
Catalog Code – GB5040
2' x 4' – 4 pcs./bundle, 32 sq. ft., 40 bundles/Unit
Catalog Code – GB5030

All bundles are double-wrapped with long corner protectors.

SPECIFICATIONS

THE FOLLOWING PARAGRAPHS ARE FOR INSERTION INTO SECTIONS OF GENERIC SPECIFICATIONS OR GENERIC/PROPRIETARY SPECIFICATIONS COVERING GYPSUM BOARD PRODUCTS. THE NATIONAL GYPSUM PRODUCTS NAME FOLLOWS THE GENERIC DESCRIPTION IN PARENTHESES.

PART 2

2.02 MATERIALS

A. Fire-Resistant Sealed Vinyl Laminated Gypsum Grid Board: A gypsum core lay-in ceiling panel with additives to enhance sag and fire resistance of the core. Panels are sealed on face, back and long edges with a 2-mil rigid vinyl film and exposed edges are factory sealed with a durable coating providing a completely sealed panel; and complying with ASTM C 1396, type X; Class 1; E 1264, type XX, Patterns E, G.

Federal Standard 209E "Airborne Particulate Cleanliness Classes in Clean Rooms and Clean Zones." (Gridstone BRAND CleanRoom Ceiling Panels).

1. Thickness: 1/2"

2. Width and length:
2' x 2'
2' x 4'

PART 3

3.03 INSTALLATION

A. Install panels in lay-in suspension systems with edges concealed by flanges of suspension members. Cut panels to fit tightly at borders and penetrations so that cut edges are concealed by trim pieces and escutcheons.

PACKAGING

2' x 2' – 4 pcs./bundle, 16 sq. ft., 80 bundles/Unit
Catalog Code – GB5044
2' x 4' – 4 pcs./bundle, 32 sq. ft., 40 bundles/Unit
Catalog Code – GB5045

All bundles are double-wrapped with long corner protectors.

SPECIFICATIONS

THE FOLLOWING PARAGRAPHS ARE FOR INSERTION INTO SECTIONS OF GENERIC SPECIFICATIONS OR GENERIC/PROPRIETARY SPECIFICATIONS COVERING GYPSUM BOARD PRODUCTS. THE NATIONAL GYPSUM PRODUCT NAME FOLLOWS THE GENERIC DESCRIPTION IN PARENTHESES.

PART 2

2.02 MATERIALS

A. Fire Resistant Vinyl Laminated Gypsum Grid Board: A gypsum core lay-in ceiling board with additives to enhance sag and fire resistance of the core; surfaced with paper on the front and back and finished on the front with a 2 mil, white, stipple textured vinyl laminate; and complying with ASTM C 1396, type X; Class 1; E 1264, type XX, patterns E, G. (Gridstone Brand Ceiling Panel).

1. Thickness: 1/2"

2. Width and Length:
2' x 2'
2' x 4'

PART 3

3.03 INSTALLATION

A. Install boards in lay-in suspension systems with edges concealed by flanges of suspension members. Cut panels to fit tightly at borders and penetrations so that cut edges are concealed by trim pieces and escutcheons.

Gridstone® BRAND Hi-Strength Ceiling Panels

DESCRIPTION

Gridstone® BRAND Hi-Strength prefinished ceiling panels have a non-combustible high strength gypsum core formulated with increased uniformity and integrity which increases its sag resistance.

Gridstone Hi-Strength panels can be used for interior and exterior ceiling applications in protected, well-ventilated spaces that receive intermittent exposure to moisture.

Lightweight. Gridstone Hi-Strength 5/16" panels are 40% lighter in weight than standard gypsum ceiling panels.

Quick, dry installation. Gridstone Hi-Strength Ceiling panels score and snap clean and install easily in standard exposed grid systems.

Pre-decorated. The sturdy white vinyl laminate eliminates additional finishing.

Do not install panels in areas exposed to continuous high humidity such as saunas, steam rooms, gang showers, and indoor pools per ASTM C840, 17.3.1.1.

For exterior application, protect grid panels from direct exposure to weather, water and continuous high humidity. Under no circumstances should water be in contact with the back of the panels.

Overlaid insulation may cause excessive panel deflection and is not recommended. These materials may cause dulling, discoloration, softening and other permanent damage to the vinyl surface.

Gridstone Hi-Strength panels are not listed in fire-rated assemblies.

USDA Acceptance: Gridstone Hi-Strength panels are accepted by the USDA for use in food service and food processing areas.

TECHNICAL DATA

SURFACE BURNING CHARACTERISTICS

ASTM E 84
Flame Spread: 5
Smoke Developed: 0

WEIGHT

5/16" Hi-Strength - 1.24 lbs/SF

SOUND ATTENUATION

ASTM E 1414 Test Method
Ceiling Attenuation Class
(CAC)-41 dB

LIGHT REFLECTANCE

LR 1 (75% or greater)

RECOMMENDATIONS

Gridstone Hi-Strength ceiling panels are designed to be mounted in standard 15/16" exposed tee grid systems or environmental type grids for severe conditions, with grids either 2' x 2' or 2' x 4'. Grid installation should be conducted according to manufacturer's specification.

Each panel must be supported on all four (4) edges.

Cross ventilation must be provided in unheated or enclosed space above ceiling panels.

General: Install panels in lay-in suspension systems with edges concealed by flanges of suspension members. Cut panels to fit tightly at borders and penetrations so that cut edges are concealed by trim pieces and escutcheons.

Cleaning: Common dirt and stains on the vinyl surface can be removed with mild soap or detergent in lukewarm water. Use a light scrubbing action with a cloth, sponge or soft brush.

If the suitability of any cleaning agent is unknown, check its effect on the Gridstone Hi-Strength panel surface in a hidden area before attempting to remove a field stain.

NOTE: Vinyl laminate on face of 2' x 2' Gridstone Hi-Strength panel is directional. Install with all factory edges parallel (same direction).

DECORATION

Gridstone Hi-Strength Ceiling panels are factory-finished decorative products which do not require painting. However, if desired, Gridstone can be painted with the following products:

1. Two coats of alkyd or latex enamel.
2. Oil primer with finish coat of oil or latex paint.
3. Two coats of latex paint.

PACKAGING

2' x 2' – 6 pcs./bundle, 24 sq. ft., 80 bundles/Unit
Catalog Code – GB5020
2' x 4' – 6 pcs./bundle, 48 sq. ft., 40 bundles/Unit
Catalog Code – GB5010

All bundles are double-wrapped with long corner protectors.

SPECIFICATIONS

THE FOLLOWING PARAGRAPHS ARE FOR INSERTION INTO SECTIONS OF GENERIC SPECIFICATIONS OR GENERIC/PROPRIETARY SPECIFICATIONS COVERING GYPSUM BOARD PRODUCTS. THE NATIONAL GYPSUM PRODUCT NAME FOLLOWS THE GENERIC DESCRIPTION IN PARENTHESES.

PART 2

2.02 MATERIALS

A. Vinyl laminated Gypsum Grid board: A gypsum core lay-in ceiling panel with additives to enhance sag resistance of the core; surfaced with paper on the front and back and finished on the front with a 2 mil, white, stipple textured vinyl laminate; and complying with ASTM C 1396, Class 1, E 1264 Type XX, Patterns E, G (Gridstone BRAND Hi-Strength Ceiling Panels)

1. Thickness: 5/16"
2. Width and length:
2' x 2'
2' x 4'

PART 3

3.03 INSTALLATION

A. Install panels in lay-in suspension systems with edges concealed by flanges of suspension members. Cut panels to fit tightly at borders and penetrations so that cut edges are concealed by trim pieces and escutcheons.

DESCRIPTION

Gold Bond® Foil Back Gypsum Board consist of a fire-resistant gypsum core encased in heavy natural-finish paper on the face side and strong liner paper on the backside to which aluminum foil is laminated. The ends are square cut and finished smooth.

BASIC USES

Foil Back Gypsum Board can be used for exterior walls and ceilings in new construction and remodeling. The aluminum foil, laminated to the back surface, is a vapor retarder to keep interior moisture within the building at a suitable comfort level. For use with furred masonry, wood or steel framing, Gold Bond Foil Back Gypsum Board is effective for single-layer applications and as a base layer in double-layer applications where a vapor retarder of 1.0 perm or less is required.

ADVANTAGES

1. In tests conducted according to ASTM Test Procedure E 96 (desiccant method), 1/2" Foil Back Gypsum Board showed a performance of 0.06 perm compared to 34 perm for 1/2" regular gypsum board and 28 perm for 1/2" gypsum board with two coats of flat latex paint.
2. In-place cost of Foil Back Gypsum Board installation is lower per thousand sq. ft. than a similar installation for regular gypsum board and polyethylene-film retarder installed separately.
3. Easy-to-handle Foil Back Gypsum Board is adaptable to virtually all exterior wall and ceiling construction: wood frame, furred masonry.

LIMITATIONS

1. Not recommended for use where exposure to moisture and high outside temperature is extreme and continuous. Under these conditions, a qualified mechanical engineer should determine location of the vapor retarder.
2. Not to be used as a base for ceramic or other tile or as a base layer for prefinished vinyl wall boards in double-layer assemblies. Also, not to be used as a base for adhesively applied vinyl or other highly water-vapor-resistant wall coverings.
3. To prevent objectionable sag in ceilings, weight of overlaid unsupported insulation should not exceed: 1.3 lb./sq. ft. for 1/2" thick boards with frame spacing 24" o.c.; 2.2 lb./sq. ft. for boards with frame spacing 16" o.c. Boards 3/8" thick must not be overlaid with unsupported insulation. Unheated attic spaces should be properly ventilated.
4. Foil Back Gypsum Board is not recommended for use in hot, humid, climates such as the Southern Atlantic and Gulf Coast areas.

MATERIALS

Manufactured boards with gypsum core, paper-encased with aluminum foil laminated backing.

SIZES AND TYPES

Thickness	Width	Length
1/2"	4'	6' to 16'
5/8"	4'	6' to 16'

Edges: Square, tapered or Sta-Smooth.

APPLICABLE STANDARDS

ASTM C 1396

TECHNICAL DATA

SURFACE BURNING CHARACTERISTICS

(ASTM E 84)

Flame spread: 15

Smoke developed: 0

WEIGHT

1/2" Regular - 1.6 lbs/SF

5/8" Type X - 2.2 lbs/SF

FIRE RESISTANCE RATINGS

Foil Back Gypsum Board has not been used in fire resistance tests. Fire resistance ratings represent the results of tests on assemblies made up of specific materials in a specific configuration. When selecting construction designs to meet certain fire resistance requirements, caution must be used to ensure that each component of the assembly is the one specified in the test. Further, precaution should be taken that assembly procedures are in accordance with that of the tested assembly. (For copies of specific tests, call 1-800-NATIONAL or 1-800-628-4662.)

RECOMMENDATIONS

Examine and inspect materials to which gypsum board is to be applied. Remedy all defects prior to installation of gypsum board. Any defects in the finished installation due to misaligned framing or other cause will be the responsibility of the work performed under that section of the specification and such defects shall be remedied under that section of the specification

Gypsum board should be applied first to ceiling at right angles to framing members, then to walls.

Boards of maximum practical length should be used so that an absolute minimum number of end joints occur. Board edges should be brought into contact with each other but should not be forced into place.

Gypsum board joints at openings should be located so that no end joint will align with edges of openings unless control joints will be installed at these points. End joints should be staggered, and joints on opposite sides of a partition should not occur on the same stud.

Gypsum board should be held in firm contact with the framing member while fasteners are being driven. Fastening should proceed from center portion of the gypsum board toward the edges and ends. Fasteners should be set with the heads slightly below the surface of the gypsum board in a dimple formed by the hammer or power screwdriver. Care should be taken to avoid breaking the face paper of the gypsum board. Improperly driven nails or screws shall be removed.

For best painting results, all interior surfaces, including joint compound, should be clean, dust-free and not glossy. To improve fastener and joint concealment, a prime coat of drywall primer is recommended to equalize the porosities between surface paper and joint compound.

See page 63, *Environmental Conditions and Limitations*.

GYPSUM SYSTEMS

Nonload-Bearing Steel Frame Partitions

DESCRIPTION

Steel framed drywall partitions are comprised of steel floor and ceiling tracks, steel studs and Gold Bond Gypsum Board which is attached with self-drilling drywall screws. Metal products are to meet or exceed all applicable ASTM standards.

Gypsum board may be applied horizontally or vertically in single or double layers. In double layer construction, the face, or finish layer, may be Durasan panels adhesively applied to the base layer. For specific fire and sound ratings for this system, see test data on pages 11 through 26.

ADVANTAGES

1. Openings provided throughout the length of the steel studs permit the easy horizontal routing of water, gas and electrical conduit. These openings may also be used to install C.R. Channel stiffeners where increased rigidity is required. Interruption of the floor or ceiling track allows the vertical installation of larger utilities.
2. Fire resistance: 1-, 2-, 3- and 4-hour fire ratings have been assigned to these systems (see pages 11-26).
3. Sound resistance: where a superior Sound Transmission Class is required, it can be achieved through the use of several variations with this system.

TECHNICAL DATA

PARTITION HEIGHTS

Light Gauge Steel Studs are designed to frame nonload-bearing partitions which are limited in height by deflection resulting from extraneous horizontal forces. For any given horizontal load, the amount of deflection increases as the height of the partition increases.

Tables 1 and 2 on the next page show maximum partition heights based on specific design criteria. The height limits shown are based on the gypsum board

and the steel studs acting as a composite section to provide a maximum deflection of $L/120$, $L/240$, $L/360$

(L = partition height in inches) with a horizontal load of 5 psf, 7.5 psf, and 10 psf of partition surface.

Increased rigidity may be obtained by placing stiffener channels through the steel stud cut-outs, by using two layer application of gypsum board or by decreasing stud spacing.

Standard 25 and 20 gauge studs, recommended for interior partitions, have height limits as shown in Tables 1 and 2. Gypsum board must be attached to full height on both sides of studs with Type S Bugle Head Drywall Screws (Type S-12 for 20 gauge studs) spaced not more than 12" o.c. on all studs when framing is 24" o.c. and 16" o.c. if framing is 16" o.c. or less. Screw lengths must be not less than $3/8$ " greater than the total thickness of the gypsum board being fastened.

Light steel 20 gauge studs are designed for exterior, nonload-bearing curtain wall systems, but are also used for interior partitions to provide more rigidity or greater heights than can be obtained with Standard 25 gauge studs.

LIMITATIONS

1. Maximum stud spacing for single layer application of $1/2$ " and $5/8$ " gypsum board is 24" o.c. If $3/8$ " gypsum board is used, it must be applied in two layers, with the second layer adhesively applied; 24" o.c. stud spacing may be used.
2. Where long, continuous runs of this wall system are employed, control joints must be provided every 30' or less.
3. Where structural movement may impose direct loads on these systems, isolation details are required.
4. Partitions should not be used where frequently exposed to excessive moisture unless all surfaces

are waterproofed.

5. To prevent weakening due to calcining, gypsum board should not be exposed to temperatures over 125°F for extended periods of time.
6. Gypsum board joints on single layer, or the face layer on two layer applications, shall not occur within 12" of the corners of door frames unless control joints are installed at the corners.
7. For limitations regarding selection of doors and doorframes, refer to table on page 92.
8. Where reference is made to nominal gauges, 25 gauge relates to a minimum base steel of .0179", and 20 gauge to .0329".

Table 1

25 GAUGE STUDS/PARTITION LIMITING HEIGHTS					
Stud Depth	Stud Spacing	Deflection Limit	Lateral Pressure		
			5 psf (240 Pa)	7.5 psf (360 Pa)	10 psf (480 Pa)
1-5/8 in. (41.3mm)	12 in. (305mm)	L/120 L/240 L/360	11-2 (3400) 8-10 (2690)	9-9 (2970)	8-10 (2690)
	16 in. (406mm)	L/120 L/240 L/360	10-7 (3230) 8-4 (2540)	8-10 (2690)	8-4 (2540)
	24 in. (610mm)	L/120 L/240 L/360	9-9 (2970) 7-11 (2410)	8-0 (2440)	
2-1/2 in. (63.5mm)	12 in. (305mm)	L/120 L/240 L/360	15-1 (4600) 11-11 (3630) 10-5 (3180)	12-4 (3760) 10-5 (3180) 9-1 (2770)	10-9 (3280) 9-6 (2900)
	16 in. (406mm)	L/120 L/240 L/360	13-3 (4040) 11-3 (3430) 9-10 (3000)	10-10 (3300) 9-10 (3000) 8-7 (2620)	9-5 (2570) 8-11 (2720)
	24 in. (610mm)	L/120 L/240 L/360	11-10 (3610) 10-7 (3230) 9-3 (2820)	9-8 (2950) 9-3 (2820) 8-1 (2460)	8-5 (2570) 8-5 (2570)
3-1/2 in. (88.9mm)	12 in. (305mm)	L/120 L/240 L/360	17-8 (5380) 15-4 (4670) 13-3 (4040)	14-3 (4340) 13-3 (4040) 11-7 (3530)	12-5 (3780) 12-0 (3660) 10-5 (3180)
	* 16 in. (406mm)	L/120 L/240 L/360	15-4 (4670) 14-4 (4370) 12-4 (3760)	12-5 (3780) 12-5 (3780) 10-10 (3300)	10-9 (3280) 10-9 (3280) 9-9 (2970)
	24 in. (610mm)	L/120 L/240 L/360	13-9 (4190) 13-5 (4090) 11-7 (3530)	11-0 (3350) 11-0 (3350) 10-1 (3070)	9-5 (2870) 9-5 (2870) 9-1 (2770)
4 in. (101.6mm)	12 in. (305mm)	L/120 L/240 L/360	19-6 (5940) 16-5 (5000) 14-4 (4370)	15-9 (4800) 14-4 (4370) 12-6 (3810)	13-8 (4170) 13-0 (3960) 11-4 (3450)
	16 in. (406mm)	L/120 L/240 L/360	17-2 (5230) 15-4 (4670) 13-4 (4060)	13-10 (4220) 13-4 (4060) 11-8 (3560)	11-11 (3630) 11-11 (3630) 10-6 (3200)
	24 in. (610mm)	L/120 L/240 L/360	15-1 (4600) 14-2 (4320) 12-4 (3760)	12-1 (3680) 12-1 (3680) 10-9 (3280)	10-5 (3180) 10-5 (3180) 9-9 (2970)
6 in. (152.4mm)	12 in. (305mm)	L/120 L/240 L/360	22-10 (6960) 22-1 (6730) 19-4 (5890)	18-7 (5660) 18-7 (5660) 16-9 (5110)	16-2 (4930) 16-2 (4930) 15-0 (4570)
	16 in. (406mm)	L/120 L/240 L/360	19-9 (6020) 19-9 (6020) 17-11 (5460)	16-2 (4930) 16-2 (4930) 15-7 (4750)	14-0 (4270) 14-0 (4270) 3-10 (4220)
	24 in. (610mm)	L/120 L/240 L/360	16-9 (5110) 16-9 (5110) 16-9 (5110)	13-5 (4090) 13-5 (4090) 13-5 (4090)	11-5 (3480) 11-5 (3480) 11-5 (3480)

Note: Limiting height tables adapted with permission from ASTM C 754. Copyright ASTM.
Tables based on tests conducted with gypsum board attached with screws
12" o.c. to framing.

*Applicable for 3/5/8" stud depth.

Table 2

20 GAUGE STUDS/PARTITION LIMITING HEIGHTS					
Stud Depth	Stud Spacing	Deflection Limit	Lateral Pressure		
			5 psf (240 Pa)	7.5 psf (360 Pa)	10 psf (480 Pa)
1-5/8 in. (41.3mm)	12 in. (305mm)	L/120 L/240 L/360	13-0 (3960) 10-4 (3150) 9-0 (2740)	11-4 (3450) 9-0 (2740)	10-4 (3150)
	16 in. (406mm)	L/120 L/240 L/360	12-1 (3680) 9-8 (2950) 8-5 (2570)	10-7 (3230) 8-5 (2570)	9-8 (2950)
	24 in. (610mm)	L/120 L/240 L/360	11-0 (3350) 8-9 (2670) 7-8 (2340)	9-7 (2920) 7-8 (2340)	8-9 (2670)
2-1/2 in. (63.5mm)	12 in. (305mm)	L/120 L/240 L/360	17-9 (5410) 13-11 (4240) 12-1 (3680)	15-6 (4720) 12-1 (3680) 10-6 (3200)	13-11 (4240) 10-11 (3300) 9-5 (2870)
	16 in. (406mm)	L/120 L/240 L/360	16-5 (5000) 12-10 (3910) 11-2 (3400)	14-4 (4370) 11-2 (3400) 9-8 (2950)	12-10 (3910) 10-0 (3050) 8-8 (2640)
	24 in. (610mm)	L/120 L/240 L/360	14-10 (4520) 11-7 (3530) 10-0 (3050)	13-0 (3960) 10-0 (3050) 8-7 (2620)	11-7 (3530) 8-11 (2720) 7-8 (2340)
3-1/2 in. (88.9mm)	12 in. (305mm)	L/120 L/240 L/360	22-6 (6860) 17-10 (5440) 15-6 (4720)	19-8 (5990) 15-6 (4720) 13-7 (4140)	17-10 (5440) 14-1 (4290) 12-4 (3760)
	* 16 in. (406mm)	L/120 L/240 L/360	20-8 (6300) 16-5 (5000) 14-3 (4340)	18-1 (5510) 14-3 (4340) 12-6 (3810)	16-5 (5000) 12-11 (3940) 11-4 (3450)
	24 in. (610mm)	L/120 L/240 L/360	18-6 (5640) 14-9 (4500) 12-9 (3890)	16-2 (5840) 12-9 (3890) 11-2 (3400)	14-9 (4500) 11-7 (3530) 10-1 (3070)
4 in. (101.6mm)	12 in. (305mm)	L/120 L/240 L/360	25-1 (7650) 19-11 (6070) 17-4 (5280)	21-11 (6680) 17-4 (5280) 15-0 (4570)	19-11 (6070) 15-8 (4780) 13-7 (4140)
	16 in. (406mm)	L/120 L/240 L/360	23-1 (7040) 18-4 (5590) 15-11 (4850)	20-2 (6150) 15-11 (4850) 13-9 (4190)	18-4 (5590) 14-5 (4390) 12-6 (3810)
	24 in. (610mm)	L/120 L/240 L/360	20-9 (6320) 16-5 (5000) 14-3 (4340)	18-1 (5510) 14-3 (4340) 12-4 (3760)	16-5 (5000) 12-10 (3910) 11-2 (3400)
6 in. (152.4mm)	12 in. (305mm)	L/120 L/240 L/360	33-9 (10290) 26-9 (8150) 23-5 (7140)	29-6 (8990) 23-5 (7140) 20-6 (6250)	26-9 (8150) 21-3 (6480) 18-7 (5660)
	16 in. (406mm)	L/120 L/240 L/360	30-10 (9400) 24-6 (7470) 21-4 (6500)	27-0 (8230) 21-4 (6500) 18-9 (5720)	24-6 (7470) 19-5 (5920) 17-0 (5180)
	24 in. (610mm)	L/120 L/240 L/360	27-2 (8280) 21-7 (6580) 18-10 (5740)	23-10 (7260) 18-10 (5740) 16-7 (5050)	19-1 (5820) 17-3 (5260) 15-0 (4570)

09 29 00

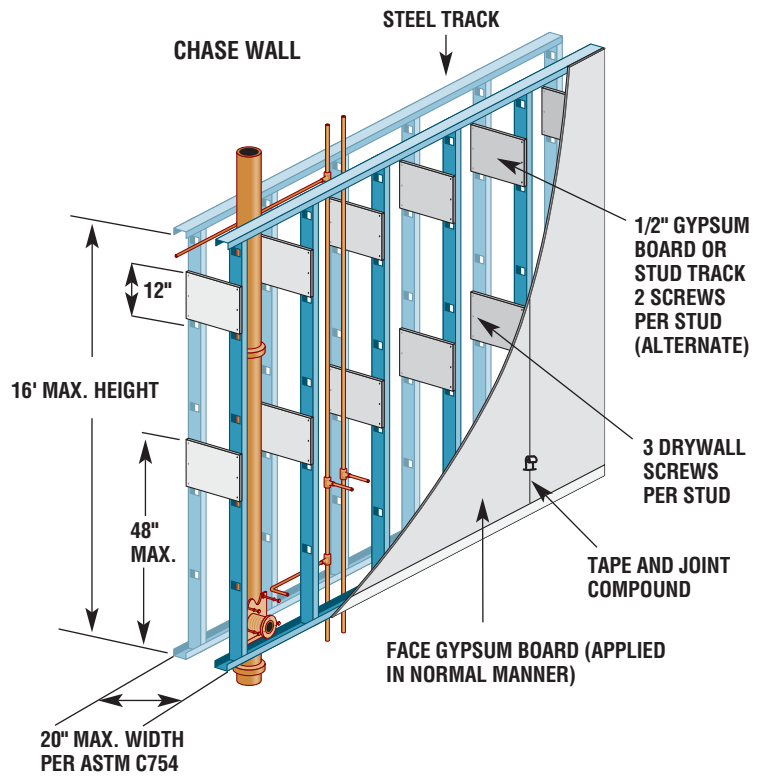
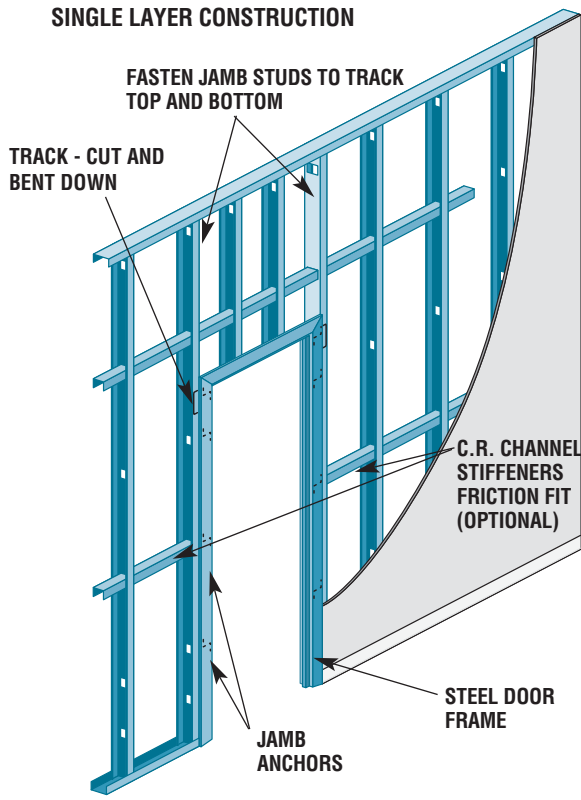

FRAMING REQUIREMENTS AT DOORS

Door Weight	Jamb Steel Studs Min. Base Steel, In.	(Type of Door Frame)			(Special Details) Bracing Over Headers	(Requires Mechanical Closure)	Partition Height Limits* Stud Size				
		Knock Down Alum.	Knock Down Steel	Fixed Steel			1 5/8" (41.3mm)	2 1/2" (63.5mm)	3 5/8" (92.1mm)	4" (102mm)	6" (152mm)
Up to 50 lbs. (23 kg)	0.0179	X	X	X		NA**	10'(3048mm)	14'(4267mm)	15'(4572mm)	14'(4267mm)	
	0.0179	X	X	X	X	10'(3048mm)	12'(3657mm)	16'(4876mm)	17'(5181mm)	16'(4876mm)	
	0.0329	X	X	X	X	—	16'(4876mm)	21'(6400mm)	22'(6705mm)	22'(6705mm)	
50 lbs. (23 kg) to 80 lbs. (36 kg)	0.0179		X	X	X	—	10'(3048mm)	14'(4267mm)	15'(4572mm)	14'(4267mm)	
	0.0179	X			X	X	10'(3048mm)	12'(3657mm)	14'(4267mm)	15'(4572mm)	
	0.0179			X	X	X	12'(3657mm)	14'(4267mm)	16'(4876mm)	17'(5181mm)	
	0.0329			X			10'(3048mm)	14'(4267mm)	15'(4572mm)	15'(4572mm)	
	0.0329		X	X	X	X	12'(3657mm)	16'(4876mm)	17'(5181mm)	17'(5181mm)	
80 lbs. (36 kg) to 120 lbs. (54 kg)	0.0329 dbl. web to web			X			16'(4876mm)	21'(6400mm)	22'(6705mm)	22'(6705mm)	
	0.0329 dbl. web to web	X			X		16'(4876mm)	21'(6400mm)	22'(6705mm)	22'(6705mm)	
80 lbs. (36 kg) to 120 lbs. (54 kg)	0.0179			X	X	X	12'(3657mm)	14'(4267mm)	15'(4572mm)	14'(4267mm)	
	0.0329	X	X		X	X	12'(3657mm)	16'(4876mm)	17'(5181mm)	17'(5181mm)	
	0.0329 dbl. web to web			X	X		16'(4876mm)	21'(6400mm)	22'(6705mm)	22'(6705mm)	

* For a specific partition having a door opening compare above partition height limits with height tables on page 88. The lower height table governs.

** NA – Not Allowed.



25 & 20 GAUGE STUDS

"C" shaped metal studs fabricated from galvanized steel. 20 gauge studs are for curtainwall construction or more rigid partitions.

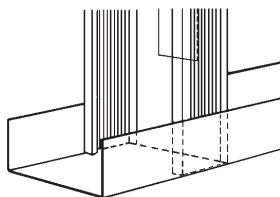

FURRING CHANNEL

Used as cross furring members for attachment of gypsum board or lath on ceiling or furred masonry walls.

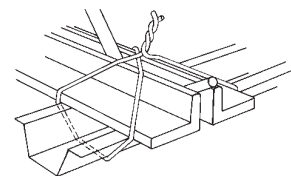

25 & 20 GAUGE TRACK

Fastened at floor and ceiling to support the steel studs. Track is channel-shaped and fabricated from galvanized steel.

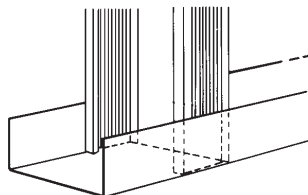

RESILIENT FURRING CHANNEL

Used as cross furring members for attachment of gypsum board and improves sound isolation on ceilings and partitions.

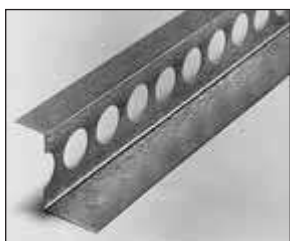
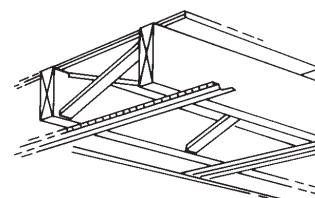

Z FURRING CHANNEL

Generally used on the inside of exterior masonry walls to support rigid foam insulation and to provide a fastening surface for gypsum board.

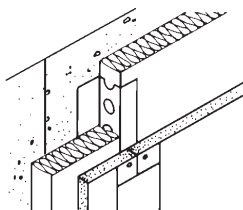

FLOOR & CEILING RUNNER 2" x 2" 20 GAUGE

Used as a utility floor and ceiling runner. Also used in vertical shaftwall inside corner application.

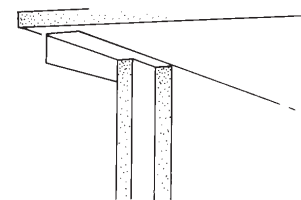

COLD ROLLED CHANNEL

Used in suspended ceilings and as stiffeners in stud partitions.

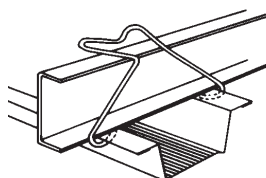

L RUNNER

Perforated – Ceiling or floor support for 2" solid lath and plaster partition.

Plain – Ceiling support for 2" solid gypsum board partition using 1" shaftliner.

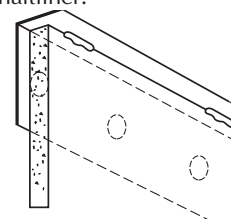

*Metal products are not manufactured by National Gypsum Company

09 29 00

Accessories*



GYPSUM BOARD CORNERBEAD

Used to reinforce exterior gypsum board corners. For use with all gypsum board thicknesses, single or double layer application.

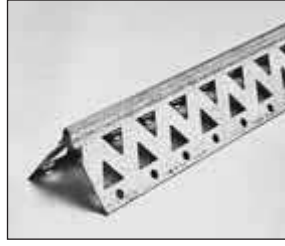
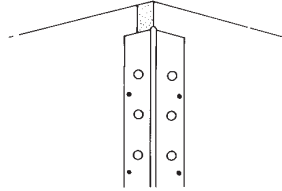

ARCH CORNERBEAD

Can be used straight for exterior corners or flanges, or may be snipped and bent to form arches.

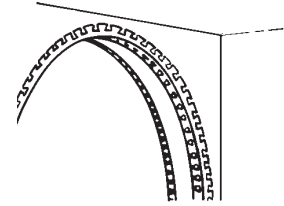

J GYPSUM BOARD CASING

Provides a finished edge at door and window jambs by slipping over edge. Is face nailed and exposed surface finished with joint treatment.

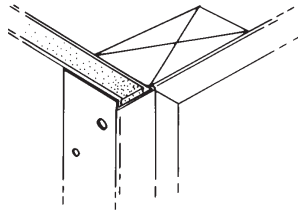

E-Z STRIP® EXPANSION JOINT

Designed for drywall or veneer plaster systems. A vinyl extrusion used as an expansion or control joint for ceilings or partitions.

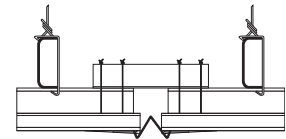

J GYPSUM BOARD CASING

(Reveal Trim)
Used at door, window, inside corners when facing must be isolated from abutting elements. Requires no joint treatment finish.

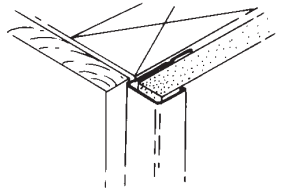

.093 ZINC CONTROL JOINT

Designed as an expansion or control joint for ceiling and partition areas for both drywall or veneer plaster systems.

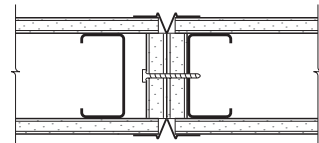

L GYPSUM BOARD CASING

Used as a finished edge at door and window jambs. Is face nailed and exposed surface finished with joint treatment.

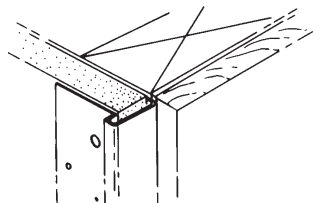

*Accessories are not manufactured by National Gypsum Company

DETAILS

STUD SPLICE

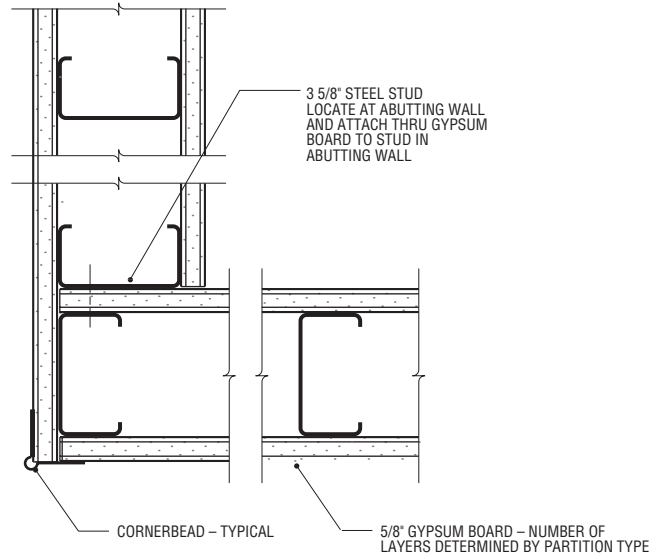
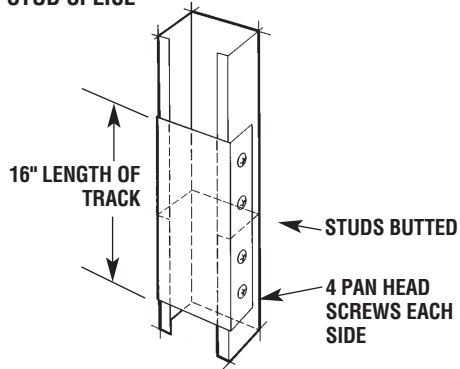

CORNER DETAIL

09250E
Scale 3" = 1'-0"

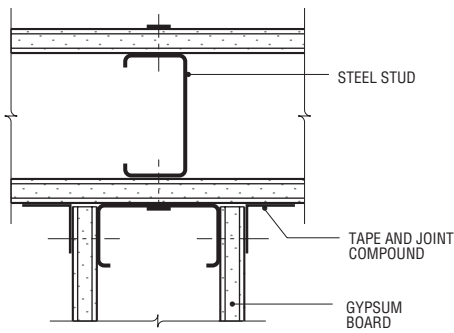

PARTITION INTERSECTION

09250F
Scale: 3" = 1'-0"

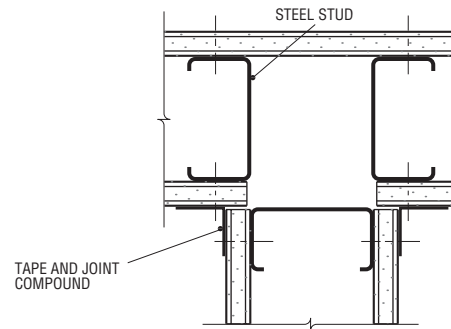

ALTERNATE PARTITION INTERSECTION

09250G
Scale: 3" = 1'-0"

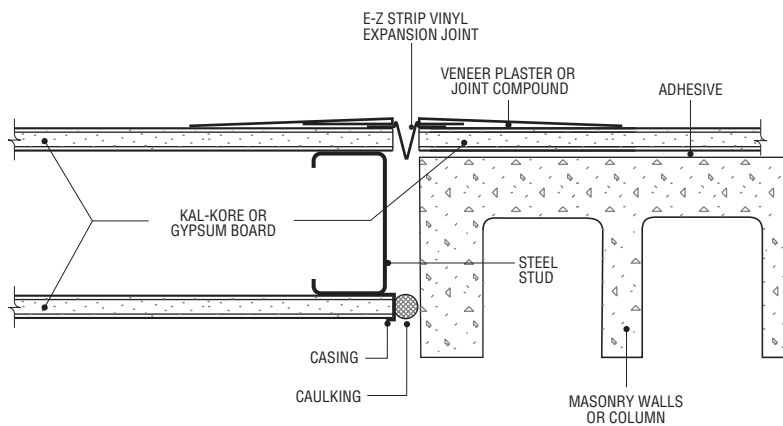

JOINT WHERE WALL FRAMING CHANGES

09250CC
Scale: 3" = 1'-0"

09 29 00

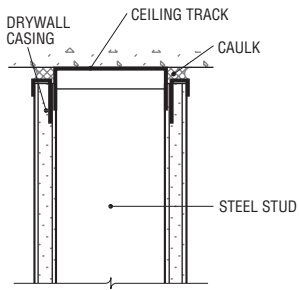

ATTACHMENT TO CONCRETE SLAB

09250H
Scale: 3" = 1'-0"

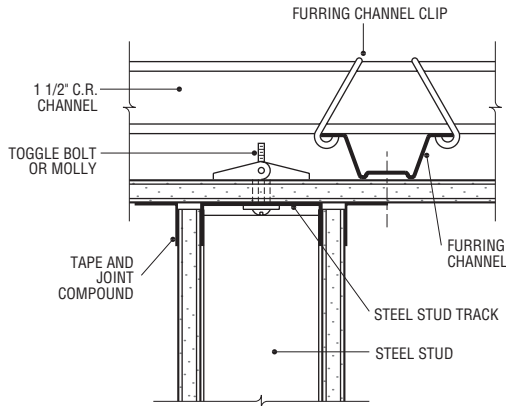

ATTACHMENT TO SUSPENDED CEILING

09250I
Scale: 3" = 1'-0"

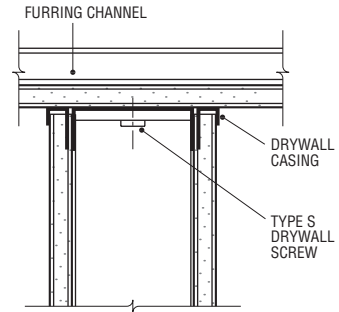

ATTACHMENT TO FURRED CEILING

09250J
Scale: 3" = 1'-0"

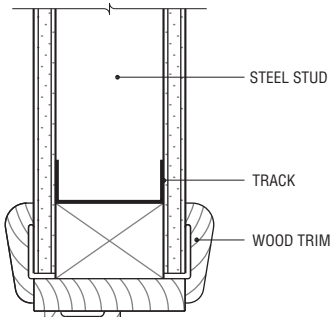

DOOR HEAD DETAIL - WOOD

09250K
Scale: 3" = 1'-0"

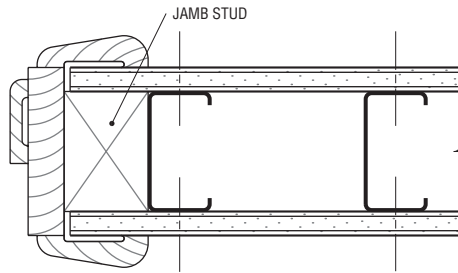

DOOR JAMB DETAIL - WOOD

09250N
Scale: 3" = 1'-0"

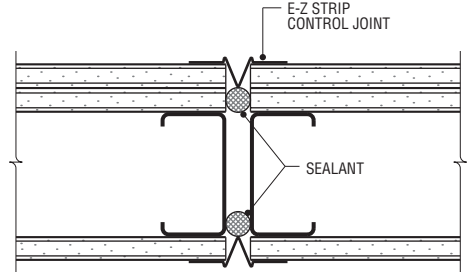

WALL CONTROL JOINT

09250M
Scale: 3" = 1'-0"

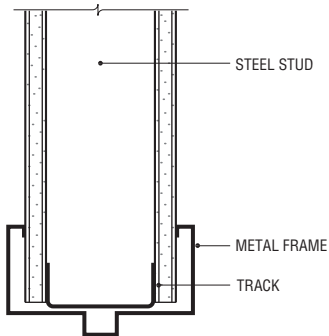

DOOR HEAD DETAIL - METAL

09250L
Scale: 3" = 1'-0"

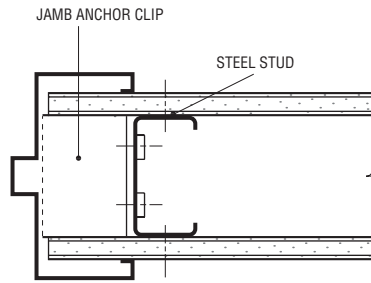

DOOR JAMB DETAIL - METAL

09250O
Scale: 3" = 1'-0"

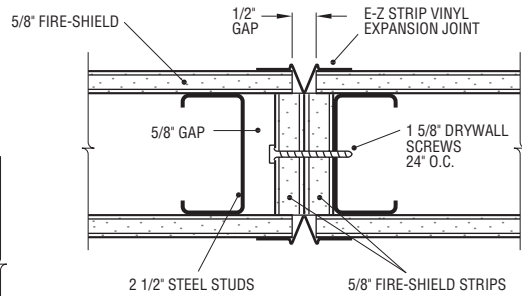

ONE HOUR FIRE RATED CONTROL JOINT DETAIL
Based on Warnock Hersey Report No. WHI-651-0318.1
and Factory Mutual Design No. W 1B-1 hr.

09250P
Scale: 3" = 1'-0"

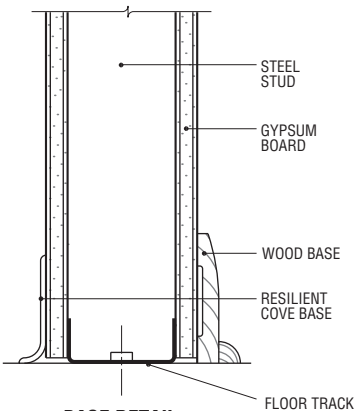

BASE DETAIL

09250Q
Scale: 3" = 1'-0"

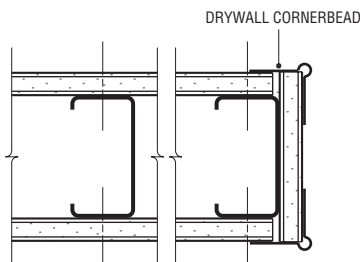

PARTITION END DETAIL

09250R
Scale: 3" = 1'-0"

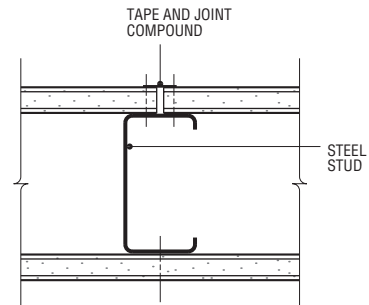

BUTT JOINT DETAIL

09250S
Scale: 3" = 1'-0"

RECOMMENDATIONS

1. FRAMING

Align floor and ceiling tracks to ensure plumb partition. Secure track with suitable fasteners at a maximum of 24" o.c. Position studs in track on 16" or 24" centers by rotating into place for a friction fit. Steel studs shall be installed with all flanges pointed in the same direction. Secure studs located adjacent to door and window frames, partition intersections and corners with 3/8" Pan Head Type S Screws driven through both flanges of studs and tracks or by using a stud clincher.

2. SINGLE LAYER OR FIRST PLY

Cut gypsum board to allow for a 1/8" to 1/4" gap between gypsum board and floor to prevent potential wicking.

Apply gypsum board with the length parallel or at right angles to the studs. Center abutting ends or edges over the stud flanges.

For metal framing, screws shall be Type S, of a length to provide not less than 3/8" penetration into framing and shall be spaced 24" o.c. max. If no adhesive is used, standard fastener spacings shall prevail.

For non-fire-rated construction, locate all attaching screws 12" o.c. when framing is 24" o.c. and 16" o.c. when framing is 16" o.c. or less. For fire-rated construction, vertical application, space screws 12" o.c. in the field and 8" o.c. along the vertical abutting edges unless otherwise specified. Attach the gypsum board to Steel Studs with Type S Drywall Screws using an electric, drywall screwdriver with a #2 Phillips bit. For vertical gypsum board application with studs 24" o.c., erect the gypsum board on one side of the partition, screw attaching to open end of stud flange first at vertical gypsum board joints. Complete the gypsum board application to the entire side of the partition in this manner. For the opposite side, cut the first gypsum board 2' wide so that joints will be staggered. Fasten this and succeeding gypsum boards to all studs on this side. When partition face is complete, return to the first side and complete screw attachment of gypsum board to all intermediate studs.

Make door and window framing openings of such size that when the gypsum board is secured to the studs, it will fit snugly into the steel frames.

3. FACE LAYER

Mechanical attachment of face layer for fire or sound rated constructions shall be made in accordance with the specifications for the system selected. When the face ply is attached with mechanical fasteners and with no adhesive between plies, the maximum spacing and minimum penetration recommended for screws should be the same as for single ply application.

SPECIFICATIONS

THE FOLLOWING PARAGRAPHS ARE FOR INSERTION INTO SECTIONS OF GENERIC SPECIFICATIONS COVERING METAL FRAMING PRODUCTS.

VERIFY DESCRIPTIONS OF METAL FRAMING PRODUCTS WITH MANUFACTURER.

PART 2 PRODUCTS

2.02 MATERIALS

A. METAL FRAMING

1. Studs: 1 5/8", 1 1/2", 3 5/8", 4" and 6" C shaped studs, weighing 312 lbs., 370 lbs., 448 lbs., 472 lbs., and 607 lbs. per 1000 lin. ft. with min. base steel of 0.0179", galvanized, and complying with ASTM C 645.
2. Track: 1 5/8", 2 1/2", 3 5/8", 4" and 6" U shaped track with 1" legs, weighing 244 lbs., 303 lbs., 378 lbs., 404 lbs. and 539 lbs. per 1000 lin. ft. with min. base metal of 0.0179", galvanized and complying with ASTM C 645.
3. 1 5/8", 2 1/2", 3 5/8", 4" and 6" U shaped track with 1 1/4" legs, weighing 278 lbs., 337 lbs., 412 lbs., 438 lbs. and 572 lbs. per 1000 lin. ft. with min. base metal of 0.0179", galvanized and complying with ASTM C 645.
4. Studs: 2 1/2", 3 5/8", 4" and 6" C shaped studs. Studs weighing 679 lbs., 817 lbs., 867 lbs. and 1105 lbs. per 1000 lin. ft. with min. base metal of 0.0329", galvanized and complying with ASTM C 645.
5. Track: 2 1/2", 3 5/8", 4" and 6" U shaped track with 1.177" legs, weighing 604 lbs., 740 lbs., 785 lbs. and 1027 lbs. per 1000 lin. ft. with min. base metal of 0.0329", galvanized and complying with ASTM C 645.
6. Z Furring Channels: 1", 1 1/2" and 2" Z shaped channels, weighing 201 lbs., 236 lbs. and 268 lbs. per 1000 lin. ft. with min. base steel of 0.0179", galvanized and complying with ASTM C 645.
7. Floor & Ceiling Runner: L shaped runner weighing 545 lbs. per 1000 lin. ft. with min. base steel of 0.0329", galvanized.

PART 3 EXECUTION

3.01 INSTALLATION

- A. General: In accordance with ASTM C 754, the manufacturer's recommendations and National Gypsum Company "Gypsum Construction Guide."

INSTALLATION

SHELF BRACKET

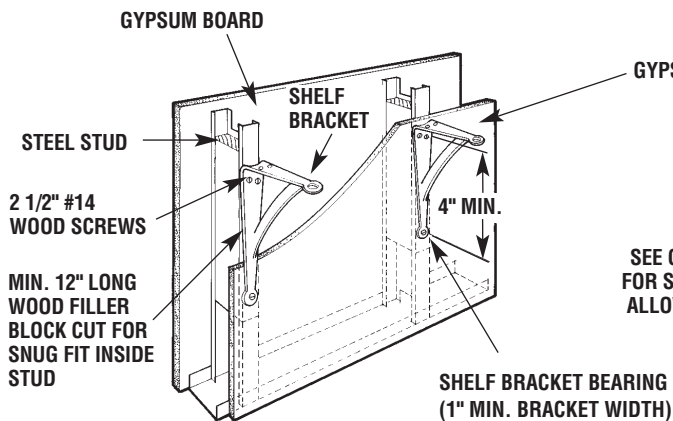

SHELF BRACKET BETWEEN STUDS

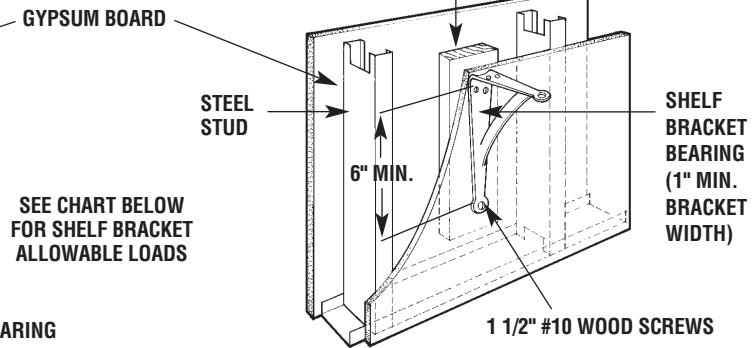

SHELF BRACKET BETWEEN STUDS

Allowable Load With Wood Blocks

Wood Block with 1/2" (12.7 mm) gypsum board	40 ft. lbs. per bracket (54 N-M)
Wood Block with 5/8" (15.9 mm) gypsum board	70 ft. lbs. per bracket (95 N-M)

Allowable Load With Sheet Metal (.0239)

.0239 sheet metal substituted for wood with 1/2" (12.7 mm) gypsum board	40 ft. lbs. per bracket (54 N-M)
.0239 sheet metal substituted for wood with 5/8" (15.9 mm) gypsum board	50 ft. lbs. per bracket (68 N-M)

SHELF BRACKET

Allowable Load

Wood Block	80 ft. lbs. per bracket (108 N-M) – 2' o.c. (610 mm)	40 ft. lbs. per bracket (54 N-M) – 4' o.c. (1219 mm)
Without filler blocks using min. #10 sheet metal screws into screw stud	50 ft. lbs. per bracket (68 N-M) – 2' o.c. (610 mm)	25 ft. lbs. per bracket (34 N-M) – 4' o.c. (1219 mm)

EXTRA HEAVY LOADS

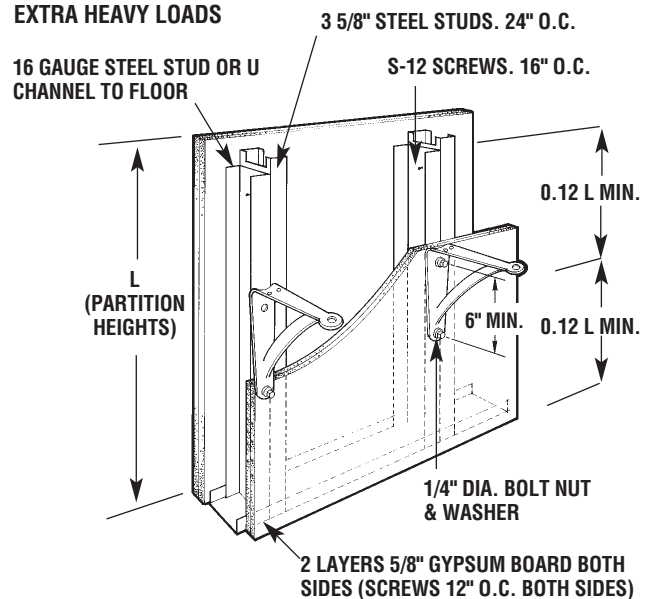

FLUSH-TO-WALL ATTACHMENTS

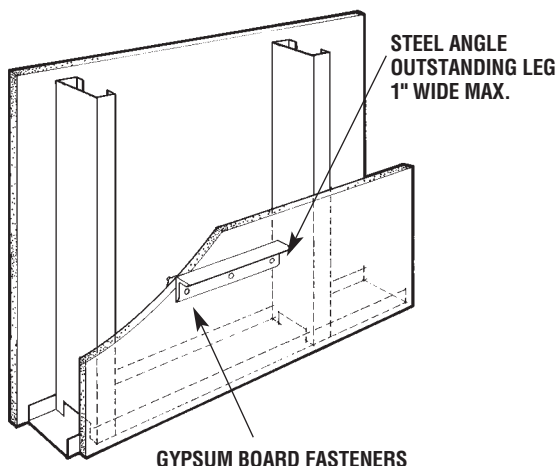

GYPSUM BOARD FASTENERS

Type Fastener	Size	Allowable Load	
		1/2" (12.7 mm) Gypsum Board	5/8" (15.9 mm) Gypsum Board
Hollow	1/8" (3.2 mm) dia. SHORT	50 lbs.(23 kg)	—
Wall	3/16" (4.8 mm) dia. SHORT	65 lbs.(29 kg)	—
Screw	1/4" (6.4 mm), 5/16" (7.9 mm)	65 lbs.(29 kg)	—
Anchors	3/8" (9.4 mm) dia. SHORT	—	90 lbs.(41 kg)
	3/16" (4.8 mm) dia. LONG	—	95 lbs.(43 kg)
	1/4" (6.4 mm), 5/16" (7.9 mm), 3/8" (9.4 mm) dia. LONG	—	—
Common	1/8" (3.2 mm) dia.	30 lbs.(14 kg)	90 lbs.(41 kg)
Toggle	3/16" (4.76 mm) dia.	60 lbs.(27 kg)	120 lbs.(54 kg)
Bolts	1/4" (6.4 mm), 5/16" (7.9 mm), 3/8" (9.4 mm) dia.	80 lbs.(36 kg)	120 lbs.(54 kg)

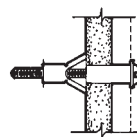

HOLLOW WALL SCREW ANCHOR

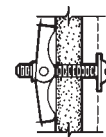

COMMON TOGGLE BOLT

DESCRIPTION

There are three types of steel furring members for the screw attachment of gypsum board ceilings.

1. Furring Channels
2. Resilient Furring Channels
3. Steel Studs

All three are suitable for fastening to the lower chord of steel joists or to carrying channels in suspended ceiling constructions. Furring Channels are secured with clips or tie wires. Resilient Furring Channels shall be secured with wire ties. Steel Studs shall be attached with tie wires as shown on page 99. Gold Bond Gypsum Board shall be applied using gypsum drywall screws spaced not greater than 12" o.c.

RECOMMENDATIONS

These furring systems, when employed with normal steel joist construction and gypsum board, constitute non-combustible construction and, in addition, fire resistance ratings are achieved as indicated on page 25.

LIMITATIONS

Lighting and other fixtures shall be supported by framing; do not use gypsum board to support them.

For large expanses of these ceiling systems with perimeter relief, control joints must be located a maximum of 50' o.c. in either direction; without perimeter relief, 30' o.c. maximum in either direction.

RECOMMENDATIONS

DIRECT ATTACHMENT

1. Space and position furring channels in accordance with manufacturer recommendation. Wire tie Resilient Furring Channels, Steel Studs or Furring Channels as shown on page 100.
2. Apply gypsum board with its long dimension at right angles to the channels. Locate gypsum board butt joints over the center of the furring channels. Attach gypsum board with 1" self-drilling drywall screws 12" o.c. located not less than 3/8" nor more than 1/2" from edges.

SUSPENDED

1. Install 1 1/2" channels 4' o.c. with No. 8 ga. hanger wire spaced a maximum of 4' o.c. along carrying channels. Attach Furring Channels spaced not more than 24" o.c. perpendicular to 1 1/2" C.R. Channels with double strand of saddle tied No. 16 ga. galvanized tie wire, or 1 1/2" Furring Channel Clips.
2. Apply gypsum board with its long dimension at right angles to the Furring Channels. Locate gypsum board butt joints over the center of Furring Channels. Attach gypsum board with 1" self-drilling drywall screws 12" o.c. in the field of the board 8" or 12" o.c. at butt joints, located not less than 3/8" or more than 1/2" from edges.

DETAILS

SPLICE JOINT FOR STUDS

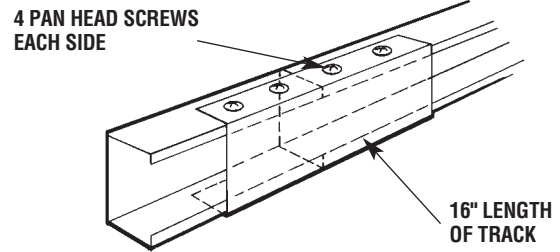

FURRING CHANNEL SPLICE JOINT

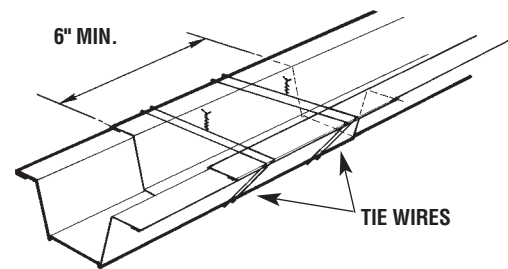

SPECIFICATIONS

See CSI Metal Framing Specifications on page 97.

INSTALLATION

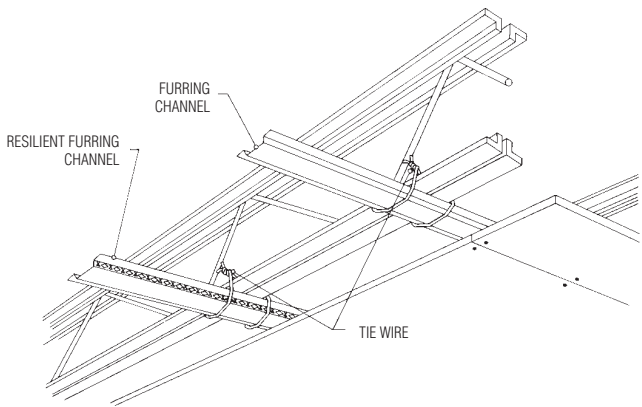

FURRING CHANNELS

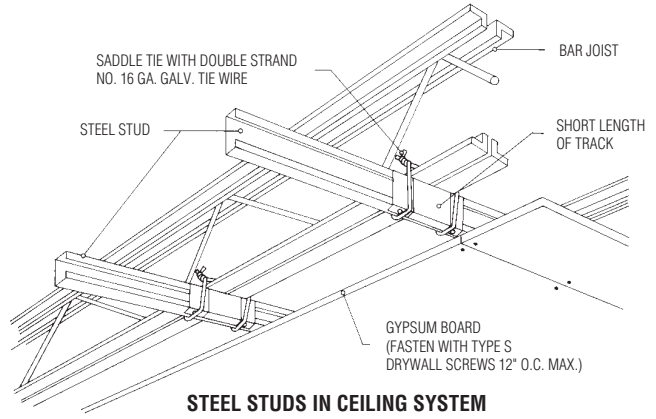

STEEL STUDS IN CEILING SYSTEM

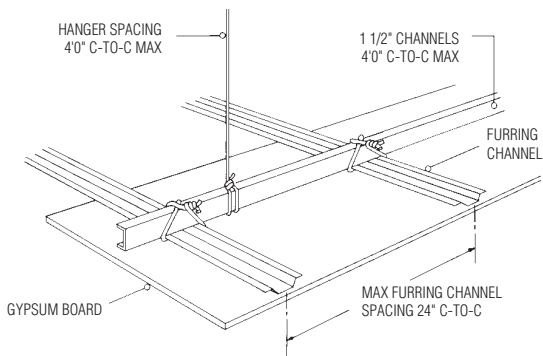

FURRING CHANNEL DETAILS

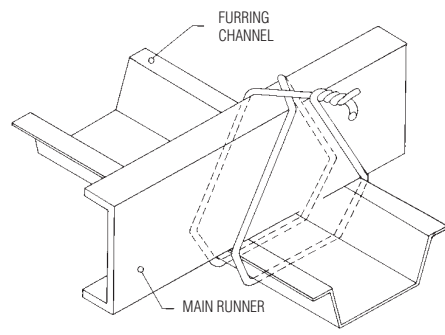

SADDLE TIE

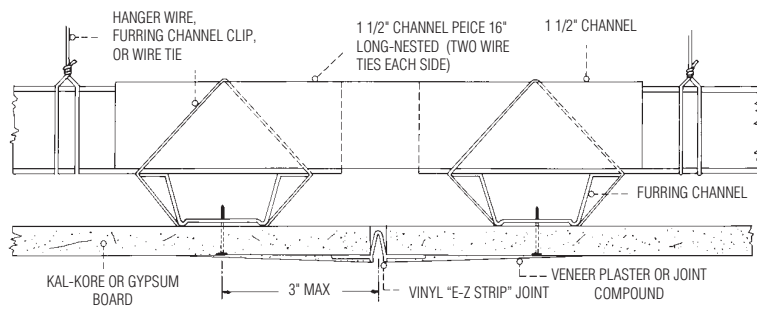

CONTROL JOINT PARALLEL TO FURRING CHANNELS

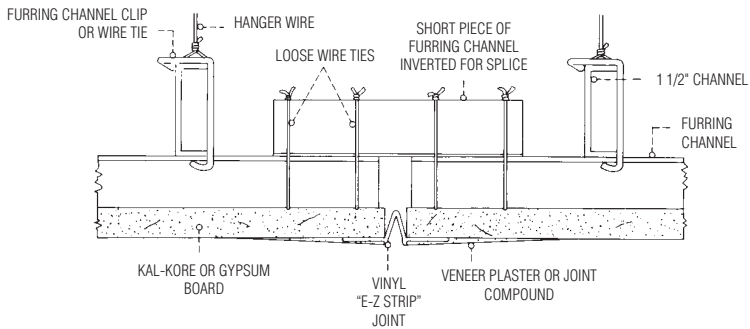

CONTROL JOINT PERPENDICULAR TO FURRING CHANNELS

DESCRIPTION



STANDARD APPLICATION

Standard application (single nailing) Regular Gold Bond Gypsum Board is usually applied directly to wood framing members. Ceilings are applied first, then sidewalls. Boards should be accurately cut and joints abutted but not forced together. Horizontal application, long edges at right angles to nailing members, is preferred for it minimizes joints and strengthens the wall or ceiling. Nails shall be spaced not to exceed 7" on ceilings, or 8" on sidewalls, a minimum of 3/8" and a maximum of 1/2" from edges and ends of gypsum board. Gypsum board nails or annular ring nails, such as the GWB-54 illustrated above, are recommended. For a description of the various types of Gold Bond Gypsum Boards, refer to pages 58 through 89.

DOUBLE NAILING

Double nailing is an alternate method of attachment devised to minimize nail-pops. This system requires doubling up on the field nails. The total quantity of nails used does not double, however, since maximum nail spacing is increased to 12" o.c. and conventional nailing is used on the perimeter. Application is accomplished by first single nailing the field of the board, starting at the center and working toward ends and edges. Another nail is then driven in close proximity (2" to 2 1/2") to each of the first nails. The first series of nails are then struck again to ensure the board is drawn tightly to the nailing member.

FLOATING ANGLE METHOD

Floating angle method of gypsum board application eliminates the use of the perimeter nails at interior corners and where ceilings and walls meet. This method reduces the stress and strain on the board if framing settles. Reference ASTM C 840, Section 9.

ADHESIVE NAIL-ON METHOD

Apply drywall adhesive to face of studs or joists in continuous beads. Reference ASTM C 840 Section 10.

FIRE RESISTANCE RATINGS

Where fire ratings are required, refer to pages 12, 13, 22, and 23. For complete construction details consult the specific test report.



SCREW APPLICATION

Screw application is often preferred as the screw holds the gypsum board tight against the framing when applied as recommended. Type W 1 1/4" Drywall Screws are driven with an electric screw gun equipped with adjustable screw depth control and a #2 Phillips bit. If framing is spaced up to 16" o.c., screws are spaced 12" o.c. max on ceilings and 16" o.c. max on walls. If framing is spaced 24" o.c., screw spacing must not exceed 12" o.c. Minimum screw penetration shall be 5/8" for wood studs.

RECOMMENDATIONS

Cut gypsum board to allow for a 1/8" to 1/4" gap between gypsum board and floor to prevent potential wicking.

1/2" or 5/8" gypsum board single layer application is recommended for interior finishing of all buildings with wood frame construction. The use of

5/8" gypsum board or 1/2" High Strength Ceiling Board on ceilings will minimize sagging. During cold weather the use of polyethylene film as a ceiling vapor retarder is not recommended unless ceiling insulation is installed *prior* to application of gypsum board.

LIMITATIONS

1. 1/4" Gold Bond Gypsum Board should be applied only to existing surfaces and should not be applied directly to framing members, except when used with other thicknesses in double layer systems tested for specific purposes. Existing walls and ceilings should be sound, flat, level and without void spaces. 1/4" thick gypsum board should be applied with a combination of mechanical fasteners, nails or screws, and adhesive that will bond to the substrate surface covering. Nails or screws should penetrate framing spaced not over 24" o.c. Adhesive should be applied between framing members to bond the gypsum board to the substrate.
2. 3/8" Gold Bond Gypsum Board should not be used on nailing members over 16" o.c. When applied to ceilings, the gypsum board must be applied with the paper bound edges at right angles to the nailing members and shall not be used to support insulation. 1/2" or 5/8" Gypsum Board should not be used on nailing members over 24" o.c. When applied to ceilings with the nailing members exceeding 16" o.c., the gypsum board must be applied with the paper bound edges at right angles to the nailing members.
3. If gypsum board ceiling boards are nailed to cross furring, these members shall have a minimum cross section of 2" x 2" (nominal) with same

spacing limitations as above. With screws, nominal 1" x 2" furring may be used. Spacing of the framing members to receive furring must not exceed 24" o.c.

4. In single ply installation, all ends and edges of gypsum board should occur over framing members or other solid backing except where treated joints occur at right angles to framing or furring members.
5. Hold the gypsum board firmly against the framing while fastening with nails or screws. Start at the center and work toward each end and edge, spacing the fasteners as recommended for each type of application.
6. Lighting and other fixtures shall be supported by framing; do not use gypsum board to support them.
7. Gypsum board ceilings to be decorated with water-thinned spray texture shall be 1/2" or 5/8" thick and applied perpendicular to the framing. Framing shall not exceed 16" o.c. for 1/2" regular gypsum board and 24" o.c. for 1/2" High Strength Ceiling Board and 5/8" gypsum board.
8. Gypsum board ceilings to receive a spray texture finish must be primed with a sealing latex primer and allowed to dry before spraying. This is to minimize sagging of the gypsum board and discoloration problems.

The use of water-based spray textures may cause unprimed gypsum board to sag when any one or more of the following conditions exist:

1. Unventilated buildings.
2. Use of vapor retarders under certain conditions.
3. Periods of prolonged high humidity due to either weather conditions or closed building units (poor drying conditions).
4. Inadequate framing support (can occur where framing changes direction).
5. Improper type or thickness of gypsum board.

RECOMMENDATIONS

SINGLE LAYER GYPSUM BOARD APPLICATION (also Base Layer of Double Layer)

1. NAILS

Nails shall be GWB-54 or cooler type located 3/8" min. to 1/2" max. from edges and ends of board. Nails shall be a max. of 7" o.c. on ceilings and a max. of 8" o.c. on walls, except for "Double Nailing" Procedure.

2. SCREWS

Drywall screws for attaching gypsum board to wood framing shall be 1 1/4",

Type W spaced not to exceed 12" o.c. on ceilings, 16" o.c. on sidewalls where studs are 16" o.c. and 12" o.c. on sidewalls where studs are spaced 24" o.c. Screws for attaching gypsum board to gypsum board shall be Type G spaced as required.

3. STAPLES

Base layer gypsum board may be applied with power-driven staples spaced 7" o.c. on ceilings; 8" o.c. on sidewalls. Staples shall be U.S. Standard 16 gauge galvanized wire staples

with 7/16" wide crown with legs having divergent points. Legs shall be not less than 1" long for 3/8" base board, 1 1/8" long for 1/2" base board or 1 1/4" long for 5/8" base board.

4. CORNERBEADS

Cornerbead shall be nailed with gypsum board nails spaced no greater than 9" apart on each flange of the bead with the nails opposite. In lieu of nailing, cornerbead may be crimp applied 6" o.c. with a special tool.

5. ADHESIVE APPLICATION TO FRAMING

- A. Apply gypsum board adhesive to the wood framing with a caulking gun.

INSTALLATION

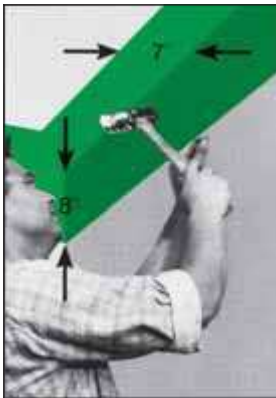

FLOATING ANGLES
No nails in shaded area.



SCREW APPLICATION
Fast, positive, fewer heads to treat.



DOUBLE NAILING
Minimizes nail-pop.



ADHESIVE/NAIL-ON
Ideal for prefinished boards.

FLOATING INTERIOR ANGLES

To minimize fastener popping in areas adjacent to wall and ceiling intersections, the floating angle method should be used for either single or double layer application of gypsum board to wood framing. This method is applicable where single nailing, double nailing or screw attachment is used. Gypsum board should be applied to ceiling first.

REPAIRING NAIL-POPS

Nail-pops are caused by lumber shrinkage after board application; loose gypsum board; improperly aligned, twisted or bowed framing; or improper nailing. Pops appearing before/during decoration should be repaired immediately. Those which occur after one or more month's heating are usually caused by lumber shrinkage and should not be repaired until after heating season. To repair, re-nail about 1 1/2" from the popped nail along the framing while applying sufficient pressure adjacent to the nail to bring board in firm contact with the framing. If the popped nail

was improperly driven, remove it. If properly driven, reseal just below the board face. Remove any loose material over resealed nail before treating nail heads with joint compound and redecorating.

ADHESIVE NAIL-ON APPLICATION

The adhesive nail-on system for application of gypsum board to wood framing strengthens the wall and minimizes the possibility of nail-popping. It reduces the number of nails in the field, provides for intimate contact and a continuous bond between the gypsum board and wood framing. All surfaces that come in contact with the adhesive should be dry, free of dirt, grease, oil or other foreign materials.

SCREW APPLICATION

Drywall screws attach gypsum board to wood or steel framing or to other gypsum boards. They pull the board tightly to the supports, minimizing surface defects due to loose boards. When properly driven, they make a uniform depression free of ragged edges and fuzz.

TECHNICAL DATA

FASTENER SELECTOR FOR WOOD FRAMING

Nail Type	Length	Gypsum Board Type	Thickness
GWB-54 [Annular Ring 1/4" (6.4 mm) head, 098 Dia. shank]	1 1/4" (31.8 mm) 1 3/8" (34.9 mm)	Regular or Foil-back gypsum board.	3/8" (9.4 mm), 1/2" (12.7 mm)
Gypsum Board Nail (Coated cooler, flat head, diamond point)	Nail length should be sufficient for 7/8" (22.2 mm) penetration into the framing member.	Regular, Foil-back or Fire-Shield (type X) gypsum board.	1/4" (6.4), 3/8" (9.4 mm) 1/2" (12.7 mm), 5/8" (15.9 mm), 1" (25.4 mm)
Where a certain degree of fire resistance is required for gypsum board assemblies and construction, nails of same or larger length, shank diameter, and head bearing area as those described in the fire test report must be used.			
Screws Type W	1 1/4" (31.8 mm)	Regular or Foil-back.	3/8" (9.4 mm), 1/2" (12.7 mm), 5/8" (15.9 mm)
Staples US Std. 16 gauge 7/16" (11.1) crown with divergent points	1" long (25.4 mm) 1 1/8" (28.6 mm) 1 1/4" (31.8 mm)	Only in first layer of multi-layer application.	3/8" (9.4 mm) 1/2" (12.7 mm) 5/8" (15.9 mm)

Maximum Framing Spacing For Single-Layer Gypsum Board

Gypsum Board Thickness	Gypsum Board Orientation to Framing	Maximum Framing Spacing
Ceilings:		
3/8" (9.5 mm) ^A	Perpendicular ^B	16" (406 mm) o.c.
1/2" (12.7 mm)	Parallel ^B	16" (406 mm) o.c.
1/2" (12.7 mm)	Perpendicular ^B	24" (610 mm) o.c.
5/8" (15.9 mm)	Parallel	16" (406 mm) o.c.
5/8" (15.9 mm)	Perpendicular	24" (610 mm) o.c.
Walls:		
3/8" (9.5 mm)	Perpendicular or Parallel	16" (406 mm) o.c.
1/2" (12.7 mm)	Perpendicular or Parallel	24" (610 mm) o.c.
5/8" (15.9 mm)	Perpendicular or Parallel	24" (610 mm) o.c.

^A Shall not support thermal insulation
^B On ceilings to receive hand or spray-applied water-based texture material either 1/2" (12.7 mm) gypsum ceiling board (ASTM C 1396/C 1396M) shall be applied perpendicular to framing; other gypsum board products shall be applied perpendicular to framing and board thickness shall be increased from 3/8" (9.5 mm) to 1/2" (12.7 mm) for 16" (406 mm) o.c. framing and from 1/2" (12.7 mm) to 5/8" (15.9 mm) for 24" (610 mm) o.c. framing.

DETAILS

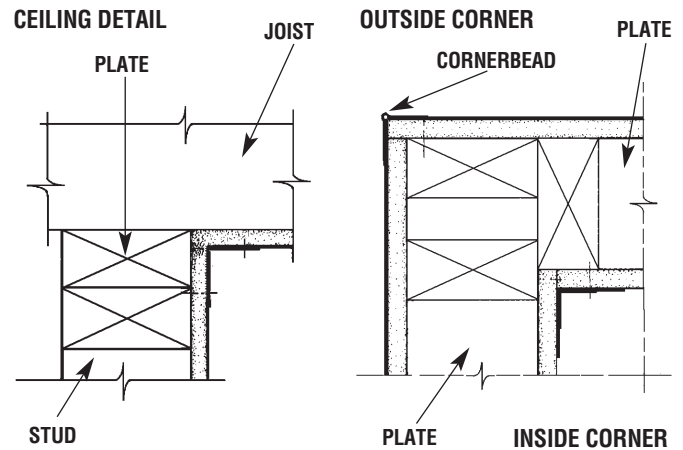

SPECIFICATIONS

See CSI 3-Part format Generic/Proprietary Specifications on page 120.

09 29 00

Wood Frame Walls and Ceilings/Double Layer Construction

DESCRIPTION

The Gold Bond double layer system consists of a face layer of gypsum board job-laminated to a base layer of gypsum board, or gypsum sound deadening board applied with power driven screws or staples, or nailed to the framing in the conventional manner.

DETAILS

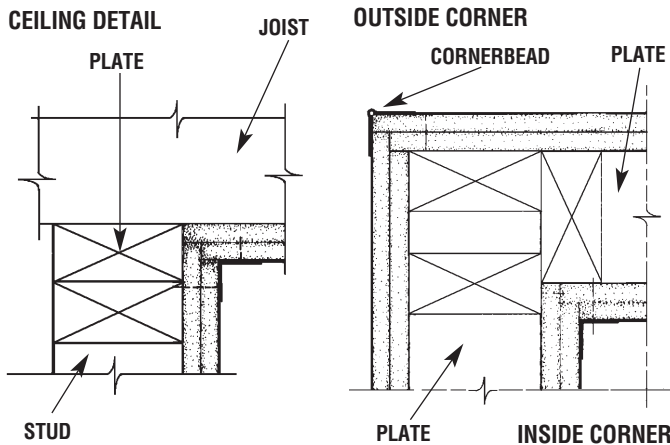

RECOMMENDATIONS

DOUBLE LAYER GYPSUM BOARD

1. Base layer

The first layer may be specified the same as single layer application except that fasteners shall be driven flush with the board surface and joints will not be treated. Base layer must not be secured to framing with clips.

2. Adhesive Application of Face Layer, General

- All joints shall fall at least 10" from parallel joints in the base layer. Adhesive shall be: (select one)
- ProForm all-purpose ready mix joint compound or Sta-Smooth setting type compound applied with a notched spreader to the back side of the finish layer.
- Adhesive is applied with a caulking gun. Align board edges. Reference ASTM C 840, section 9.

3. Adhesive Application, Regular Gypsum Board

The finish layer shall be positioned on the wall or ceiling within 10 minutes (unless otherwise specified above) and held in place with sufficient temporary (nails) (Type G Drywall Screws) (bracing) to ensure adequate contact and alignment of the gypsum boards. When the bond has developed (usually 24 hours) the temporary (fasteners) (bracing) shall be removed. Resulting holes shall be filled flush to the surface with Joint Compound and the joints shall be finished. Cornerbead shall be applied at all exterior angles.

4. Adhesive Application, Prefinished Gypsum Board

- Pre-bow board by storing overnight in such a position that the ends of each board curve away from the base layer when put in vertical mounting position.
- Apply ready-mix or Sta-Smooth joint compound in nominal 5" ribbons of four 1/4" x 1/4" beads located around the perimeter and center of the boards (approximate coverage for ready-mix is 9-10 gal./1000 sq.ft and Sta-Smooth is 50-60 lbs./1000 sq.ft.). An alternative is 2" diameter daubs 1/2" thick, 16" o.c. (approximate coverage for ready-mix is 5 1/2"-6 gal./1000 sq.ft. and Sta-Smooth is 30 - 35 lbs./1000 sq.ft.).
- Temporarily brace, as required, to ensure proper contact and edge alignment of boards.

5. Mechanical Application of Face Layer

Mechanical attachment of face layer for fire or sound rated constructions shall be made in accordance with the specifications for the system selected.

For non-rated construction, nails used in wood framing to supplement adhesive shall be type GWB, of a length to provide 7/8" minimum penetration into framing and shall be spaced 16" o.c. max. Screws used in wood framing shall be Type W, of a length to provide minimum 5/8" penetration into the framing and shall be spaced 24" o.c. max. If no adhesive is used, standard fastener spacings shall prevail.

SPECIFICATIONS

See CSI 3-Part format Generic/Proprietary Specifications on page 120.

INSTALLATION

Cut gypsum board to allow for a 1/8" to 1/4" gap between gypsum board and floor to prevent potential wicking.

In double layer construction use any of the following appropriate laminating adhesives: (1) Sta-Smooth Compound or Sta-Smooth Lite for fast hardening; (2) All-Purpose Joint Compound for spreading on the back surface of the finish layer boards; (3) drywall adhesive meeting ASTM C 557.

Base layer is applied on ceilings, then sidewalls, secured with 1 1/4" Type W Screws 12" o.c. on ceilings, 16" o.c. on walls; nails located 7" o.c. on ceilings; 8" o.c. on sidewalls; staples 5" o.c. on ceilings and 6" o.c. on sidewalls.

Finish layer is temporarily nailed or braced until adhesive dries. On walls, prefinished boards, applied vertically, can be pre-bowed, nailed just top and bottom.

RECOMMENDATIONS

- Double layer gypsum board application over wood framing is recommended for the ultimate in wall surfacing and in areas where increased fire protection and better sound insulation are desired between rooms. (For test results see pages 13-14 of this guide.) Custom built homes, commercial buildings and party walls between apartments would be considered appropriate areas for double layer application.

- 2. Laminating is an excellent way to apply Durasan, the vinyl-surfaced gypsum board. This method eliminates any visible attachment.
- 3. Sta-Smooth Compound or Sta-Smooth Lite is recommended for laminating as well as for joint treatment where fast hardening is required.

LIMITATIONS

- 1. Joints of succeeding layers must not fall at the same location. For greatest strength, it is recommended that the boards of each layer be staggered so that joints of each layer are at least 10" apart.
- 2. During cold weather, maintain a room temperature of not less than 40°F during mechanical attachment of gypsum board, and between 50°F and 70°F for 48 hours before lamination, joint treatment, texturing and decoration, and continuously thereafter until completely dry.

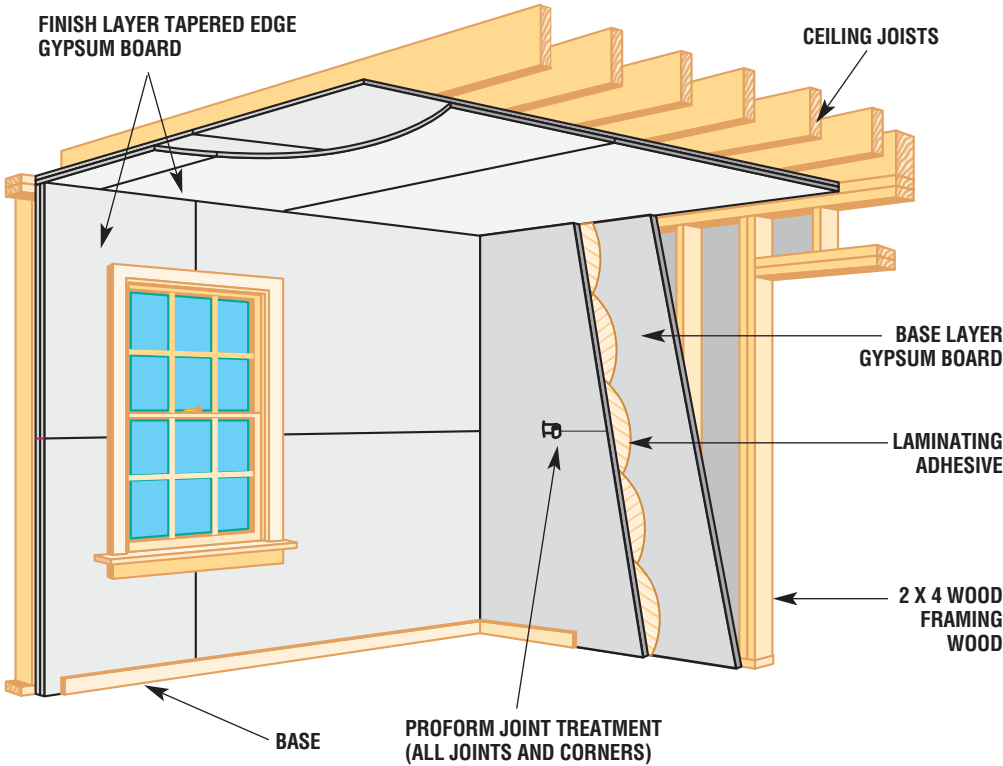

09 29 00

**SOUND TRANSMISSION CLASS 45
FIRE RESISTANCE RATING 1 HR.**

**SOUND TRANSMISSION CLASS 58
FIRE RESISTANCE RATING 2 HRS.**

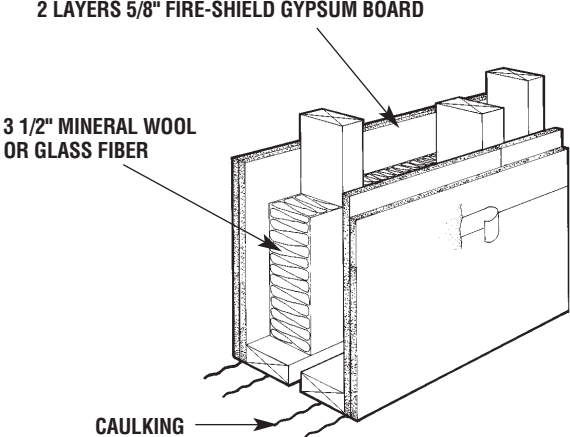
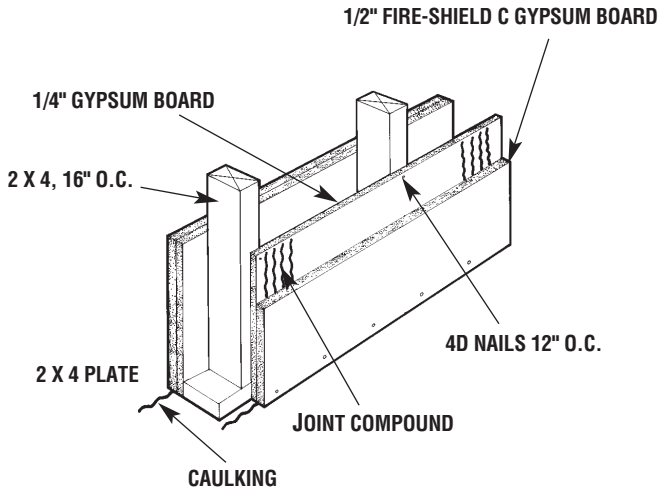

Resilient Furring Channel Construction

DESCRIPTION

Resilient Furring Channels are fabricated of galvanized steel with expanded metal legs that provide resiliency to reduce sound transmission through wood framed wall and ceiling assemblies.

STANDARD APPLICATION

Resilient Channels have punched holes spaced 1" o.c. in the leg flanges to facilitate fastening to framing members spaced either 16" or 24" o.c. The 12' long channels are applied perpendicular to the framing members and spaced not more than 24" o.c. Gypsum board is then attached to the Resilient Channels with power driven, Type S Drywall Screws spaced 12" o.c.

RECOMMENDATIONS

1. Construction, as shown in the detail below, is recommended to achieve sound and fire-rating as shown on pages 11-26.
2. A 3" wide strip of 1/2" thick gypsum board should be used at the floor line to assure a solid base for attaching the gypsum board and the base. An additional strip of gypsum board or a Resilient Furring Channel should be used at the ceiling line.

3. The point of intersection between the wall and floor shall be caulked prior to application of baseboard to obtain the best sound isolation.
4. On wood studs fasten channel through alternate flanges at each stud using 1 1/4" GWB-54 Nails or Type W Drywall Screws. Fasten both flanges at channel ends.
5. Resilient Furring Channels should be fastened to wood joists with one Type W Drywall Screw at each joist in alternate flanges. Channel ends may fall on or between joists but must be fastened to prevent any sliding movement which could create squeaking noises. When channel ends fall between joists, overlap approximately 1 1/2" and screw-attach through both legs into a wood block held above the channels, or overlap approximately 6" and fasten both channels near ends with 3/8" Type S Pan Head Screws.

LIMITATIONS

1. Spacing of Resilient Furring Channels should not exceed 24" o.c. nor span more than 24".
2. Use only 1/2" or 5/8" gypsum board with this system.

RECOMMENDATIONS

INSTALLATION (RESILIENT FURRING CHANNELS ON ONE SIDE OF PARTITION)

Wood framing shall be erected in accordance with conventional procedure, studs (16" o.c.) (24" o.c.). A 1/2" x 3" shim strip of gypsum board shall be nailed to the base plate continuously on the resilient side of the partition. An additional strip of gypsum board or a Resilient Furring Channel should be used at the ceiling line. Resilient Furring Channels shall be located horizontally, 24" o.c. max., and be secured through alternating flanges at each stud with 1 1/4" GWB-54 Nails or Type W Drywall Screws. Abutting channel ends shall be located over studs, shall be gapped and shall be fastened through both flanges.

INSTALLATION (RESILIENT FURRING CHANNELS ON CEILINGS)

Wood framing shall be erected in accordance with conventional procedure, joists (16" o.c.) (24" o.c.) Resilient Furring Channels shall be installed perpendicular to joists, spaced 24" o.c. and a maximum of 6" from the ceiling-wall line with Type W Screws through alternate flanges at each joist.

Where channel ends overlap at a joist, Type W Drywall Screws must be driven through both channels through both flanges into joist.

Where channel ends overlap between joists, wood blocking may be used to take Type W Drywall Screws driven through both channels through both flanges, or Type S Pan Head Screws may be used to fasten channel ends together.

APPLICATION OF GYPSUM BOARD

Attach gypsum board to Resilient Furring Channels with 1" Type S Drywall Screws 12" o.c. and to framing through filler strips with drywall screws 12" o.c. that penetrate framing 5/8" minimum.

Note: Screws used to attach gypsum board to resilient furring channels shall not contact wood framing.

DETAIL

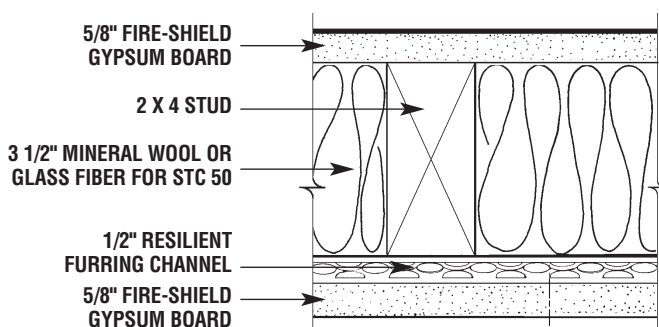

TYPICAL SECTION

SPECIFICATIONS

See CSI 3-Part format Generic/Proprietary Specifications on page 120.

INSTALLATION

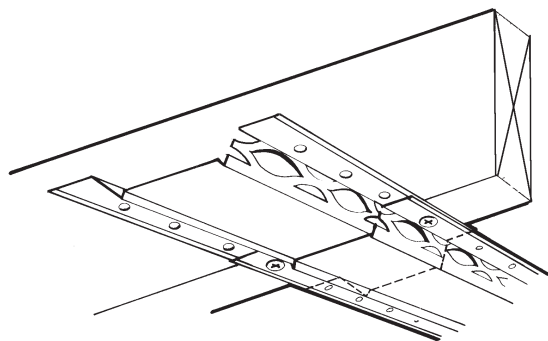

SPLICE ON JOIST
1 1/4" Type W Screws

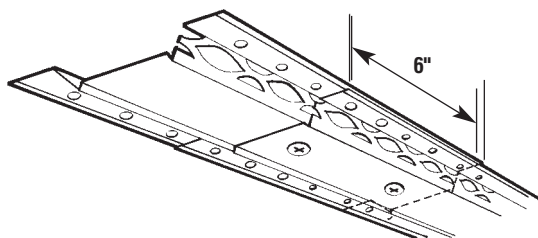

SPLICE BETWEEN JOISTS
3/8" Type S Pan Head Screws

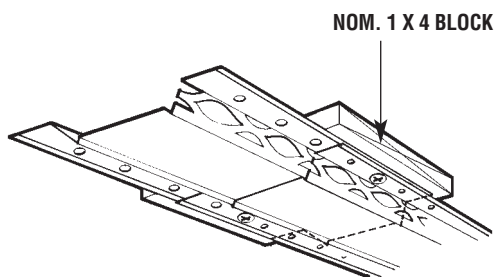

SPLICE BETWEEN JOISTS, ALT.
1 1/4" Type W Screws

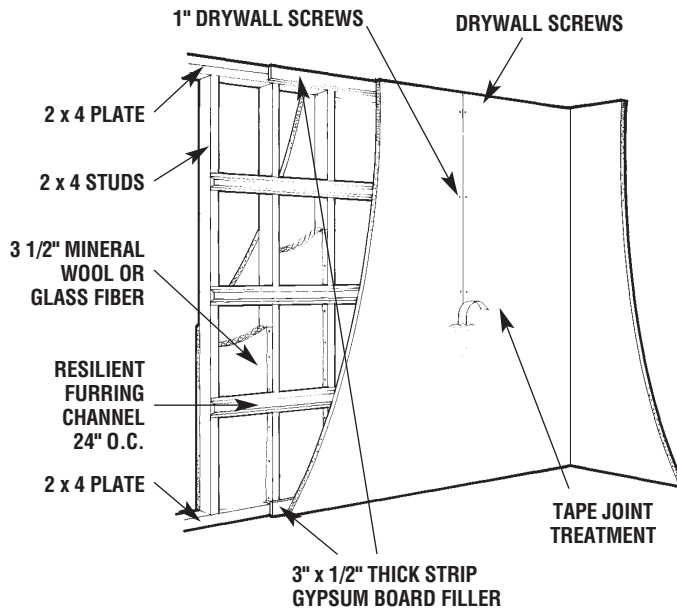

09 29 00

Gypsum Board Over Masonry

DESCRIPTION

A. Z FURRING CHANNEL

1. Application of Foam.

Z Furring Channel is used to secure rigid insulation and gypsum board to masonry walls. Insulation thickness (1", 1 1/2", 2") determines depth of Z furring web. The channel is applied vertically and fastened to the masonry wall through the short (3/4") flange with suitable masonry fasteners 24" o.c. maximum. Application is progressive. After fastening each Z Furring Channel, a 24" wide floor-to-ceiling-high insulation board is fit between the wall and the wide (1 1/4") flange.

2. Application of Gypsum Board.

Erect Gold Bond Gypsum Board either vertically or horizontally to the Z Furring Channels. Gypsum board edges or ends that run parallel to the channels shall be centered and abutted over channels. Fasten gypsum board with 1" Type S Drywall Screws spaced 12" o.c. When gypsum board erection is complete, finish all joints and screw heads in accordance with ProForm Joint Finishing System. Prefinished gypsum board may be laminated vertically to the channels with screws at top and bottom.

Limitations

Power driven fasteners should be used to secure furring only when wall is monolithic concrete. Regular concrete nails can be used for fastening to unit masonry. If block is old, test nailing should be done in advance to determine optimum size and type of nail.

B. LAMINATION

1. Application of Foam.

Insulation may be urethane foam or extruded polystyrene. Expanded bead polystyrene is not recommended. For horizontal gypsum board

application, install wood furring strips (nominal 2" wide x 1/32" greater than the foam thickness) horizontally along the wall-ceiling and wall-floor angles, where horizontal gypsum board joints will fall, and around door and window openings. For vertical gypsum board application, furring strips are required at the horizontal wall-ceiling and wall-floor lines and around door and window openings.

Masonry surface must be dry, clean and free of dust, dirt, form release agents, oil, grease or water soluble materials. Treat painted masonry as recommended for laminating to painted surfaces. Apply adhesive to the foam insulation in 3/8" dia. beads continuously around the perimeter and through the field in the long direction with the beads spaced 16" o.c. **Contact adhesive manufacturer for compatibility with foam.**

Apply the foam boards horizontally to the wall with a sliding motion and hand press entire board to ensure full contact of adhesive and wall surface.

2. Application of Gypsum Board.

ProForm All-Purpose Joint Compounds may be used. (Do not use water base compounds for laminating prefinished boards to foam.)

Permanent nails or screws 12" o.c. are required to fasten gypsum board to wood furring. Gypsum board must be installed a minimum of 1/8" from the floor. Use temporary nails or bracing as necessary to hold gypsum board boards in firm contact to the foam until adhesive has dried or set.

Limitations

1. Nails or screws used for attachment of gypsum board to furring strips must not penetrate through the furring.

- Power driven fasteners should be used to secure furring to monolithic concrete. Regular concrete nails can be used for fastening to unit masonry. If block is old, test nailing should be done in advance to determine optimum size and type of nail.
- During cold weather, room temperature between 50°F and 70°F must be maintained uniformly during application and until adhesive is thoroughly dry or premises are occupied. Provide adequate ventilation.
- Gypsum board is not recommended in areas where it will be exposed to excessive moisture or continued high humidity.

- Since the use of foam plastic insulation is regulated by many building codes, consultation with local building authorities is recommended before installation.

Since unprotected foam insulation may represent a fire hazard, it should be covered promptly and completely with gypsum board.

DETAILS

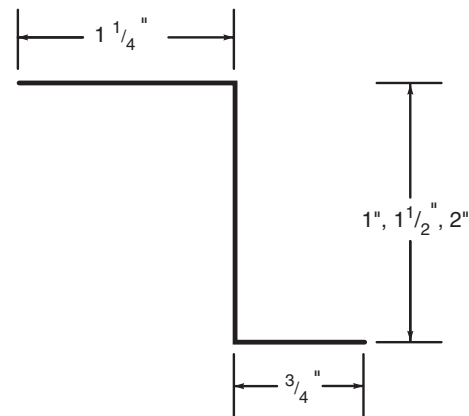

Z FURRING

SPECIFICATIONS

See CSI 3-Part format Generic/Proprietary Specifications on page 120.

RECOMMENDATIONS

Z FURRING

1. Begin application of Z furring members by positioning first piece vertically at a corner. Locate the piece on the wall adjacent to the wall being insulated first.
2. Insulation thickness determines distance of Z furring web from wall being insulated. At the appropriate distance, and with wide flange pointing toward applicator, secure Z furring with appropriate fasteners through short flange. (Note to Specifier: Power driven fasteners are not recommended for use with masonry block.)
3. Install 24" wide floor-to-ceiling insulation board, pressed snugly against web of first Z. Install next Z with wide flange overlapping edge of first insulation board. Fasten to wall through narrow flange.
4. Continue in this manner, with Z furring 24" o.c. to end of wall. Locate last Z so that web is located a distance equal to insulation thickness from adjoining wall. Cut last insulation board to fit remaining space.
5. At exterior corner, attach the Z through its wide flange, with narrow flange extending beyond the corner. Begin with a narrow strip of floor-to-ceiling insulation, wider than insulation thickness but not exceeding 3". Continue application of furring and insulation progressively as described above.
6. At windows, doors and trim areas, use wood nailers (nom. 2" wide x insulation thickness plus 1/32"). Use the nailers also at wall-floor angles to support trim and provide backing for base.
7. Apply gypsum board with 1" Type S Screws through flanges of Z furring, 12" o.c.

LAMINATION

1. Masonry or monolithic concrete shall be above grade, dry, free of dust, loose particles, oil, grease or other foreign material.
2. Joint compound used as adhesive shall be mixed to a consistency thick enough to allow a 2" daub to stick to the underside of a broad knife held parallel to the floor.
3. Apply 2" to 2 1/2" diameter daubs of adhesive 1/2" thick, 16" o.c. in both directions to the masonry wall. The adhesive layout must provide for a row of daubs located a maximum of 2" from board ends, and care must be exercised to center daubs on vertical joints. No more adhesive shall be applied to the wall than will be covered with board in 15 minutes. Approximate coverage for joint compound (powder) used as an adhesive is 30-35 lbs./1000 sq. ft.
4. Cut gypsum board to allow for 1/8" to 1/4" clearance between board and floor to prevent potential wicking.
5. Install gypsum board by hand pressing each board tight to the wall making certain that all daubs are in positive contact with the board.
6. Support boards at each corner to keep them from slipping to the floor by use of a concrete nail driven through a small block of nominal 1" lumber.
7. Butt boards to each previously positioned board to ensure flush joints.
8. If necessary to hold boards straight, plumb and in proper alignment, drive masonry nails through small wood blocks and into masonry at high points only. After adhesive is dry (24 - 48 hours) remove temporary nails.
9. Fill all holes and treat joints with tape and joint compound.

INSTALLATION

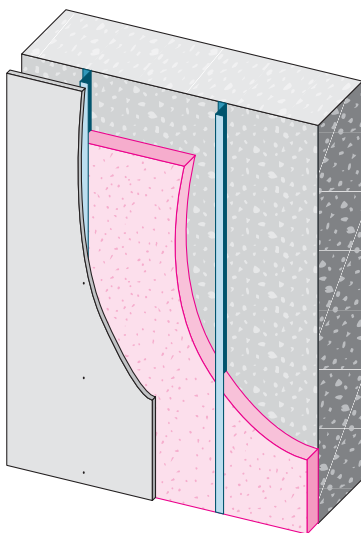

Z FURRING CHANNEL

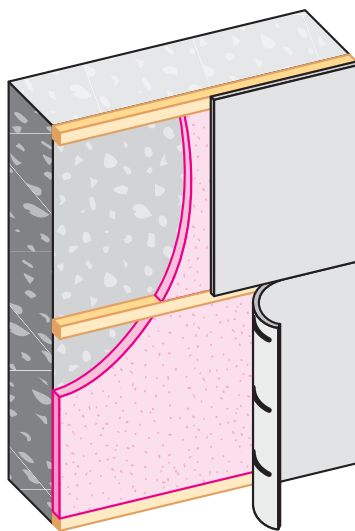

HORIZONTAL INSTALLATION WITH DRYWALL ADHESIVE

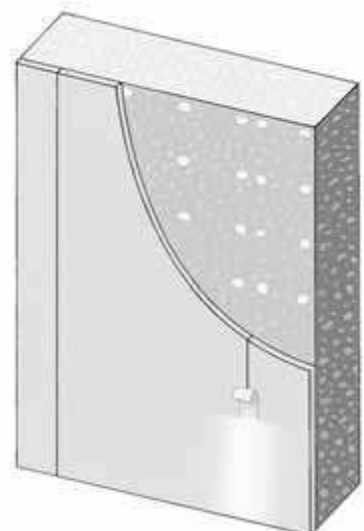

DAUB METHOD USING JOINT COMPOUND

Solid Laminated Partitions

DESCRIPTION

Laminated Partitions have been developed for use where sturdy, nonload-bearing walls are desired. The total thickness is nominal 2". 1" Fire-Shield Shaftliner is used between face layers of gypsum board.

PHYSICAL PROPERTIES

A. Fire Resistance. Fire endurance ratings have been established by the following tests:

FM WP 671 - 1 HOUR:
1/2" Regular Gypsum face boards and ProForm Brand Sta-Smooth joint compound* as laminating compound.

UL U505 - 2 HOUR:
5/8" Type X Fire-Shield face boards and ProForm Brand Sta-Smooth joint compound* as laminating compound.

UL U525 - 2 HOUR:
1/2" Fire-Shield Type C face board and ProForm Brand Sta-Smooth joint compound* as laminating compound.

UL U529 - 2 HOUR:
1/2" Fire-Shield Type C face boards and ProForm Brand Sta-Smooth joint compound* as laminating compound.

B. Sound Isolation. An STC rating of 34 has been achieved in tests conducted in accordance with ASTM E 90.

C. Economical. The laminated partition offers a substantial saving in installation time and subsequently in labor costs over other types of solid partitions. The 1" gypsum core is quickly and easily installed and the large sheets of gypsum board provide a dry finish surface in minimum time.

LIMITATIONS

The laminated partition is adapted to any type of building for nonload-bearing partitions not exceeding 12' in height. Further limitations to height are based on the partition length in the table below.

*Required for fire rating.

DETAILS

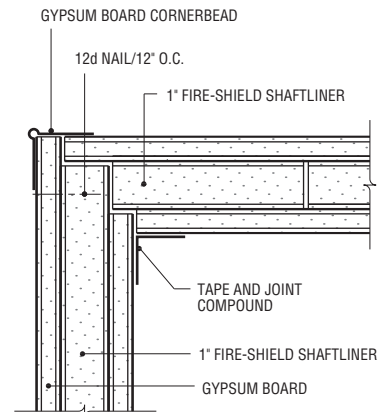

CORNER WALL DETAIL

09250U
Scale: 3" = 1'-0"

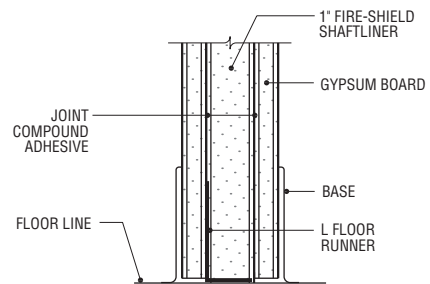

VERTICAL SECTION USING METAL FLOOR RUNNER

09250T
Scale: 3" = 1'-0"

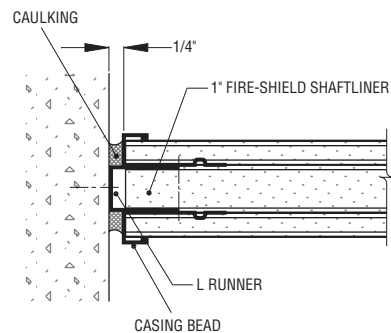

ANCHORAGE TO CONCRETE CEILINGS, WALLS OR COLUMNS

09250V
Scale: 3" = 1'-0"

TECHNICAL DATA

Maximum Ceiling Height	Partition Length Between Restraints
12' (3658 mm)	14' (4267 mm)
11' (3353 mm)	20' (6096 mm)
10' (3048 mm)	Over 20' (6096 mm)

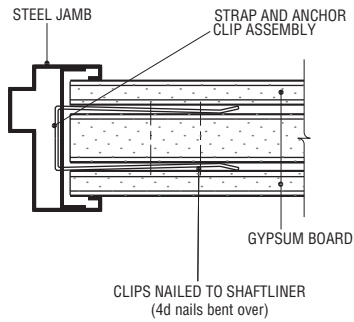

JAMB DETAIL
09250X
Scale: 3" = 1'-0"

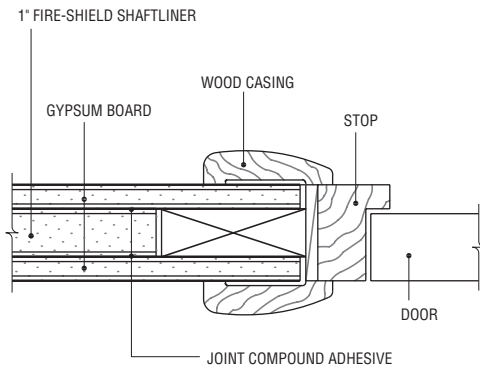

WOOD JAMB DETAIL
09250W
Scale: 3" = 1'-0"

RECOMMENDATIONS

1. Secure floor runner to floor with approved fasteners 24" o.c. Ceiling runner shall be secured in an appropriate manner to the ceiling construction. The L runner shall be used as both floor and ceiling runners in Fire-Rated construction.
2. The 1" Fire-Shield Shaftliner, cut 1/4" shorter than wall height, shall be installed vertically and shall be fastened to the floor and ceiling runners with two 1 5/8" Type S Drywall Screws, each located 2" from each edge of the Shaftliner boards.
3. Sta-Smooth Compound shall be applied evenly with a notched spreader (with 1/4" x 1/4" notches, 1 1/2" o.c.) to the back side of the 4' wide, ceiling height gypsum board face boards. Install the boards vertically to both sides of the Shaftliner. Stagger

board joints 12" from the Shaftliner joints and 24" from joints on each side of the wall.

Face boards are then screwed, 12" o.c. to the top and bottom runners with 1 7/8" Type S screws and are secured to the Shaftliner with 1 5/8" Type S Drywall Screws spaced 24" o.c. horizontally and vertically to include screws along the vertical edges of each board.

Gypsum board joints shall be reinforced with paper tape and finished with joint compound.

4. Door frames shall be vertical, plumb and true, and shall be securely anchored to floor and ceilings as shown on the plans.
5. Completed partition shall be straight and plumb.

SPECIFICATIONS

See CSI 3-Part format Generic/Proprietary Specifications on page 120.

ProForm® BRAND Joint Treatment



DESCRIPTION

National Gypsum Company produces Joint Treatment Compounds and a complete line of reinforcing tapes for the proper finishing of gypsum board joints. To ensure best results, only National Gypsum products should be used together in construction systems. Mixing with other brands is not recommended.

All National Gypsum Joint Compounds are formulated without asbestos and therefore comply with Consumer Product Safety Standards.

JOINT COMPOUNDS

Joint treatment compounds have three basic uses:

1. To embed the joint tape and to finish over the tape, the cornerbead and nail or screw heads.
2. To texture gypsum board surfaces.

3. To laminate gypsum board to an existing surface such as old plaster, masonry, or a gypsum board or backer board base.

ProForm BRAND All Purpose Joint Compound – A pre-mixed compound that may be used directly from the container. It is designed for tape application, fastener spotting, and the complete joint finishing of gypsum board. It contains sufficient binder to secure the reinforcing tape and develops its strength and hardness by drying. There are two types: regular is for use with hand tools, and machine grade, a thinner version, used in mechanical tool application. It can also be used to repair cracks in plaster walls and for skimming and texturing. Available in 61.7 lb. pails or 50 lb. and 61.7 lb. cartons. West Coast only: 47 lb. cartons. Southwest only: 48 lb. cartons.

ProForm BRAND XP Joint Compound – A pre-mixed all-purpose joint compound formulated for additional mold resistance. Can be used with XP Gypsum Board to construct wall or ceiling systems with enhanced resistance to mold. Available in 61.7 lb. pails and 50 lb. cartons.

ProForm BRAND Multi-Use Joint Compound – A multi-use ready-mix joint compound designed for all phases of drywall finishing: taping, fasteners, finishing, texturing, trims and cornerbead. Available in 3.5 gal. or 4.5 gal. cartons or 4.5 gal. pails. West Coast only: 46 lb. cartons.

ProForm BRAND Lite Joint Compound – A lightweight joint compound designed to be used for finishing gypsum board joints, spotting fasteners, finishing cornerbead and texturing. ProForm Lite is designed to make your job easier. Approximately 30% lighter

than conventional compounds, Lite pulls and sands easier and reduces shrinkage by up to 20%. Available in 4.5 gal. pails or 3.5 gal. and 4.5 gal. cartons. West Coast only: 3.59 gal. cartons.

ProForm BRAND Ultra Joint Compound – A lightweight joint compound designed to be used for finishing gypsum board, spotting fasteners and finishing cornerbead. ProForm Ultra is approximately 50% lighter than conventional ready mix and approximately 30% lighter than other lightweight products. Ultra provides a superior finish with less pocking and excellent sanding characteristics and is the lowest shrinkage ready mix on the market (10-14%). Available in 4.5 gal. pails or 3.5 gal. and 4.5 gal. cartons.

ProForm BRAND Taping Joint Compound - A ready-mix joint compound designed to enhance bond when embedding joint tape or when applying tape-on corner bead and accessories. Taping compound is also an excellent product to enhance bond when laminating gypsum board. Available in 46 lb. cartons.

ProForm BRAND Topping Joint Compound - Designed specially as a finish used over joint compound. It is not recommended for embedding paper tape or the first coat over cornerbeads. It exhibits easy working and spreading characteristics and is suitable for floating or finishing taped joints, spotting nail or screw heads and the finish coats over cornerbead. Its excellent sanding qualities make it preferred as a finishing compound. Topping Compound can also be used for texturing. Available in 61.7 lb. pails or 50 lb. and 61.7 lb. cartons. West Coast only: 49 lb. cartons.

ProForm BRAND Triple-T Compound (Taping, Topping, Texturing) - An all-purpose, powder compound used for embedding tape, for finishing and for texturing. Available in 25 lb. bags.

ProForm BRAND Texture Grade Joint Compound - An all-purpose ready-mixed material specially formulated for texturing walls and ceilings. Use to create a variety of textures, the most typical are Spray Spatter, Spatter Knockdown, Orange Peel and Skip Trowel. Bonds well with many surfaces including gypsum board, gypsum plaster and above grade interior concrete/masonry. Available in 61.7 lb. pails or 50 lb. cartons.

Storage, Ready-Mix

Storage life varies with climactic conditions, up to 6 months under good conditions. Store compound away from extreme cold or heat to avoid accelerated aging. Regularly check production dates and rotate inventory on a first-in, first-out plan.

If Ready-Mix freezes, allow material to thaw at room temperature for at least 24 hours. When thawed, turn the container upside-down for at least 15 minutes. Turn pail right side up, remove lid, and immediately remix with an electric drill. Ready-Mix should be lump free and ready to use within 1 minute. Discard all Ready-Mix that does not remix to a lump free consistency.

Stacking

Ready-Mix pails or cartons should not be stacked more than two pallets in height.

ProForm BRAND Sta-Smooth

Joint Compound - A special setting (hardening) type compound that is not affected by humidity once it has set and dried. It was developed for use in the Sta-Smooth System to reduce joint deformities such as ridging and beading. Sta-Smooth compound firmly bonds the tape to the board and the Sta-Smooth board edges to each other. Sta-Smooth compound is suitable for filling voids left in above-grade interior concrete. Required for finishing joints on exterior soffit board.

Sta-Smooth compounds are recommended for use in poor drying conditions. Recoating characteristics save trips to jobs. Product exhibits low shrinkage making it excellent for pre-filling and quick patches.

LIMITATIONS

Sta-Smooth should not be applied over moist surfaces or surfaces subject to moisture. Remove all grease, dirt and form oils from the concrete prior to application of the Sta-Smooth. Grind all projections from the concrete. Available in following types: 20, 45, 90, 210. (Numbers designate setting or hardening times in minutes.) Available in 25 lb. bags.

ProForm BRAND Sta-Smooth Lite Joint Compound - A lightweight setting compound offering the advantages of a hardening compound, but also sandable. Available in set times of 5, 20, 45, 90, 210 minutes in 18 lb. bags.

ProForm BRAND Sta-Smooth HS Joint Compound (High Strength) - Developed for use in the manufactured housing industry. A hardening or setting compound which develops high early strength. Available in set times of 20, 30, 45, 60 and 90 minutes. Available in 25 lb. bags.

Storage, Setting Compound - Storage life varies with climactic conditions. With good indoor storage - up to 12 months, high humidity - 6 months maximum.

JOINT TAPES

ProForm BRAND Joint Tape - Joint tape conceals and reinforces gypsum board joints. The tape is buffed on both sides to ensure the best working qualities and bond. A center creasing process allows easy folding for use at corners. Available in 75', 250' and 500' rolls.

ProForm BRAND Multi-Flex Tape Bead

- A combination of joint tape and metal strips laminated to form an outside or inside corner for gypsum board. It is particularly recommended for inside corners on cathedral ceilings, kneewalls, stairways, or any outside or inside corner less or greater than 90°F. It is applied with the metal side to the face of the gypsum board and is embedded into the joint compound, 100 ft. per roll.

ProForm BRAND Fiberglass Mesh Tape - A 1.9" wide, self-adhering fiberglass tape for use with Sta-Smooth compounds. 300' per roll. Not recommended for use with drying type compounds.

Varying weather conditions can impact both the quality and appearance of taped drywall joints. Relative humidity, plus temperature, will affect the working characteristics of all joint compounds.

For example, cool wet weather will slow down the drying process while hot, dry weather hastens the drying process. Exposure to winds, breezes or drafts can also affect the performance of joint compounds. Typical problems from improper drying can be cracking, excessive shrinkage, ridging and beading, banding or bond failure.

Proper precautions at the job site should always be taken to minimize the adverse effects of weather on drying. These precautions will ultimately solve the application time and expense from call backs and rework.

TECHNICAL DATA

COVERAGE TABLE

Product	Container	Approx. Coverage*
ProForm All-Purpose	47 lbs. (21.3 kg) carton	130-140 lbs./1000 sq. ft. (59-63 kg/93 sq. m.)
	48 lbs. (21.8 kg) carton	
	50 lbs. (22.7 kg) carton	
	61.7 lbs. (28 kg) pail, carton	
ProForm XP	61.7 lb. (28 kg) pail 50 lb. (22.7 kg) carton	
ProForm Taping	46 lb. (20.8 kg) carton	65-70 lbs./1000 sq. ft. (33kg/93 sq. m.)
ProForm Topping	49 lbs. (22.2 kg) carton	
	50 lbs. (22.7 kg) carton	
	61.7 lbs. (28 kg) pail, carton	
ProForm Multi-Use	4.5 gal. (17 L) pail, carton 3.5 gal. (13 L) carton	
ProForm Lite	4.5 gal. (17 L) pail, carton 3.5 gal. (13 L) carton	8.2 gal./1000 sq. ft. (33 L/93 sq. m.)
ProForm Ultra	4.5 gal. (17 L) pail, carton 3.5 gal. (13 L) carton	
Dry Powder Triple-T Compound	25 lbs. (11 kg) bag	55-65 lbs./1000 sq. ft. (25-29 kg/93 sq. m.)
Dry Powder Setting Types	25 lbs. (11 kg) bag	45-55 lbs./1000 sq. ft. (20-25 kg/93 sq. m.)
	Sta-Smooth	
	Sta-Smooth HS Sta-Smooth Lite	
	18 lbs. (8 kg) bag	

*Material usage increases with above-average use of cornerbeads.

SPECIFICATIONS

THE FOLLOWING PARAGRAPHS ARE FOR INSERTION INTO SECTIONS OF GENERIC SPECIFICATIONS OR GENERIC/PROPRIETARY SPECIFICATIONS COVERING GYPSUM BOARD ACCESSORIES. THE NATIONAL GYPSUM PRODUCT NAME FOLLOWS THE GENERIC DESCRIPTION IN PARENTHESES.

PART 2 PRODUCTS

2.01 ACCESSORIES

A. Joint Treatment:

1. Tape: 2 1/16" wide paper reinforcing tape (ProForm BRAND Joint Tape).
2. Tape: 2" wide paper reinforcing tape with metal strips laminated along the center crease to form inside and outside corners (ProForm BRAND Multi-Flex Tape Bead).
3. Tape: 1.9" wide self-adhering fiberglass tape (ProForm BRAND Fiberglass Mesh Tape).
4. Compound: Drying type pre-mixed compound (ProForm BRAND All Purpose Joint Compound, regular grade and machine grade, ProForm BRAND Topping Joint Compound, ProForm BRAND Lite Joint Compound, ProForm BRAND Ultra Joint Compound and ProForm BRAND XP Joint Compound, and ProForm BRAND Taping Joint Compound).
5. Compound: Drying type job mixed compound (ProForm BRAND Triple-T Compound).
6. Compound: Setting type job mixed chemical-hardening compound (ProForm BRAND Sta-Smooth Joint Compound, ProForm BRAND Sta-Smooth Lite Joint Compound and ProForm BRAND Sta-Smooth HS Joint Compound (High Strength)).

PART 3 EXECUTION

3.01 INSTALLATION

- A. General: In accordance with the manufacturer's recommendations, National Gypsum Company "Gypsum Construction Guide."
- B. Specific: For specific application recommendations using Joint Treatment products refer to submittal sheets. Refer to:
 - ProForm BRAND All Purpose Joint Compound 110778
 - ProForm BRAND XP Joint Compound 110965
 - ProForm BRAND Multi-Use Joint Compound 110685
 - ProForm BRAND Lite Joint Compound 110779
 - ProForm BRAND Topping Joint Compound 110777
 - ProForm BRAND Sta-Smooth Joint Compound 110626
 - ProForm BRAND Sta-Smooth Lite Joint Compound 110627
 - ProForm BRAND Sta-Smooth HS Joint Compound 110628

You may obtain copies of these sheets and all product submittal sheets directly by calling 1-800-NATIONAL (1-800-628-4662).

Joint Compound Drying Time Guide Per GA-236

Approximate Drying Times: All Purpose/Lite Ready-Mix Joint Compound

R.H.	Temperature						
	32°	40°	50°	60°	70°	80°	100°
0%	38/H	28/H	19/H	13/H	9/H	6/H	3/H
20%	2/D	34/H	23/H	16/H	11/H	8/H	4/H
40%	2.5/D	44/H	29/H	20/H	14/H	10/H	5/H
50%	3/D	2/D	36/H	24/H	17/H	12/H	6/H
60%	3.5/D	2.5/D	42/H	29/H	20/H	13.5/H	8/H
70%	4.5/D	3.5/D	2.25/D	38/H	26/H	19.5/H	10/H
80%	7/D	4.5/D	3.25/D	2.25/D	38/H	27/H	14/H
90%	13/D	9/D	6/D	4.5/D	3/D	49/H	26/H
98%	53/D	37/D	26/D	18/D	12/D	9/D	5/D

Note: R.H. = Relative Humidity D = Days (24 hour period) H = Hours

The chart above is a helpful guide in determining approximate drying times for joint compounds under a variety of humidity/temperature conditions. Shaded area is below the minimum application temperature requirement of 50° F and is not recommended for the application of joint compound.

DESCRIPTION

ProForm BRAND Perfect Spray

A decorative texture product for fast spray application to interior ceiling surfaces. Its shredded polystyrene aggregate gives this texturing product greater whiteness, better hide and bold accent. Recommended for interior ceilings that are formed of new or previously painted gypsum board or monolithic concrete or plaster. Available coarse, medium, and fine (40 lb. bag).

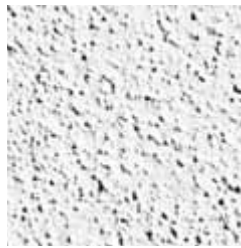

PROFORM BRAND
PERFECT SPRAY
TEXTURE-FINE



PROFORM BRAND
PERFECT SPRAY
EM - ORANGE PEEL

ProForm BRAND Perfect Spray EM

Perfect Spray EM is a non-aggregated texture product used to create a wide range of wall surfaces. When used in conjunction with textured ceilings Perfect Spray EM can be applied without overspray affecting the ceiling previously sprayed with (aggregated) Perfect Spray. By adjusting mixture consistency and/or varying the atomizing pressure, Perfect Spray EM creates an almost endless variety of textures, the most typical of which are Spray Spatter, Spatter Knockdown and Orange Peel. Surfaces can be finished with a coat of paint. Perfect Spray EM (nonaggregated) is specially formulated for easy mixing and easy pumping and is available in 50 lb. bags.

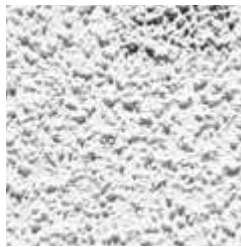

PROFORM BRAND
PERFECT SPRAY
TEXTURE-MEDIUM



PROFORM BRAND
PERFECT SPRAY
EM - SPATTER

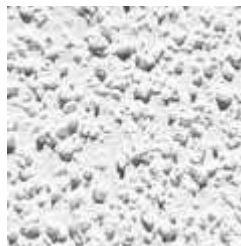

PROFORM BRAND
PERFECT SPRAY
TEXTURE-COARSE



PROFORM BRAND
PERFECT SPRAY
EM - SPATTER +
KNOCKDOWN

Perfect Spray EM Texture Application

Texturing can be, depending on desired pattern, a single- or multiple-coat operation using a spray texture gun fed by a piston or Moyno-type pump. An Orange Peel Finish is achieved with a high atomizing pressure and thin mix. A Spatter Finish uses a low atomizing pressure and heavy mix. Other finishes can be created by combining methods in two coat operations or troweling spatter patterns before fully dried (Spatter Knockdown).

Caution: Where a vapor retarder has been installed above a gypsum board ceiling, adequate ventilation must be provided during the drying period. This precaution is necessary in order to minimize the possibility of gypsum board sagging due to moisture absorption.

09 29 00

NOTE: Surfaces must be primed with a sealing primer.

APPLICATION GYPSUM BOARD

Surfaces, including joint-treated areas, must be smooth, clean and dry. First apply a coat of sealing primer. Allow primer to dry thoroughly, and maintain adequate drying conditions after application. Primer is to minimize sagging of gypsum board and discoloration or difference in sheen on ceiling surface. Add dry texture to water. Use a piston pump or Moyno-type pump with a texture gun. Minimum 3/4" I.D. material hose. A hopper-type gun with adequate air supply is also suitable. Typical coverage is 8-10 sq. ft. per lb. for aggregated and 10-30 lb. for nonaggregated

textures. Mask appropriate areas before spraying and promptly remove overspray from unprotected surfaces afterward. Follow the instructions of the spray equipment manufacturer for adjusting controls and cleaning. If a second coat is desired, allow the first coat to dry thoroughly.

NOTE: Gypsum board ceiling surfaces to be decorated with water-thinned spray texture shall be 1/2" or 5/8" thick and applied perpendicular to the framing. Framing shall not exceed 16" o.c. for 1/2" Regular Gypsum Board and 24" o.c. for 1/2" High Strength Ceiling Board and 5/8" gypsum board.

CONCRETE:

Allow concrete to cure for at least 28 days. Clip protruding wire ends and spot with rust-inhibitive primer. Remove all form oil, grease and dirt, or any loose or water-soluble material. Grind down any form ridges, and level any remaining unevenness with Sta-Smooth Joint Compound. Apply a coat of alkali-resistant, sealing primer over the entire surface to be textured.

AVAILABILITY: Contact your area National Gypsum sales representative for texture product availability.



RECOMMENDATIONS

- A. For specific recommendations on use and application of Drywall Texture products, refer to Gold Bond submittal sheets as follows:
- ProForm BRAND Perfect Spray 110629
 - ProForm BRAND Perfect Spray EM 110630
- You may obtain copies of these sheets and all product submittal sheets directly by calling your local representative or 1-800-NATIONAL (1-800-628-4662).

TECHNICAL DATA

COVERAGE TABLE: SPRAY TEXTURES

ProForm Brand Texture	Application	Aggregate	Bag size	Mixing water per bag	Typical coverage per bag
Perfect Spray	ceilings	shredded polystyrene	40 lbs. (18 Kg.)	3-4 1/2 gal. (11.4 - 17.0 L)	300-400 sq. ft. (9.7 - 12.9 sq. m.)
Perfect Spray EM	walls ceilings	none	50 lbs. (23 Kg.)	4-5 gal. (15.1 - 18.9 L)	500-1,500 sq. ft. (16.2 - 48.4 sq. m)

NOTE: Perfect Spray, Perfect Spray EM
Burning Characteristics: Flame Spread-10, Smoke Developed-25.

Materials Estimating & Coverage Guide

ESTIMATING TABLE

	Ready Mix*	Sta-Smooth	Perfect Spray	Perfect Spray EM	Joint Tape
Quantity per 1,000 sq. ft. of wallboard	140 lbs.	55 lbs.	120 lbs.	50-100 lbs.	350 ft.

ESTIMATING TABLE

Sq. Ft. of Wall/Ceiling	Wallboard Size			Ready Mix*/lbs.	Joint Tape/ft.	Sta-Smooth/lbs.	Nails/ct.	Screws/ct.
	4'x8'	4'x10'	4'x12'					
100	4	3	3	14	35	6	168	90
200	7	5	5	28	70	11	294	150
300	10	8	7	42	105	17	420	240
400	13	10	9	56	140	22	546	300
500	16	13	11	70	175	28	672	300
600	19	15	13	84	210	33	798	456
700	22	18	15	98	245	39	924	528
800	25	20	17	112	280	44	1050	600
900	29	23	19	126	315	50	1218	696
1000	32	25	21	140	350	55	1344	768
1100	35	28	23	154	385	61	1470	840
1200	38	30	25	168	420	66	1596	912
1300	41	33	28	182	455	72	1722	984
1400	44	35	30	196	490	77	1848	1056
1500	47	38	32	210	525	83	1974	1128

*Based on ProForm BRAND All Purpose

Levels of Gypsum Board Finish

The following has been excerpted from a consensus document prepared by the *Association of the Wall and Ceiling Industries-International (AWCI), Ceilings & Interior Systems Construction Association (CISCA), Gypsum Association (GA), and Painting and Decorating Contractors of America (PDCA)* as a guide to gypsum board finishing. The members of these international trade organizations are dedicated to providing the best possible job for the most reasonable cost. By incorporating the appropriate sections of this recommended specification into the project documents, the architect, general contractor, and building owner can better anticipate the final appearance of the decorated wall and ceiling system.

This has also been issued by the Gypsum Association as document GA-214.

SCOPE

This recommended specification describes various levels of finish of gypsum board surfaces prior to the application of specific types of final decoration. The recommended level of finish of gypsum board wall and ceiling surfaces varies with the final decoration to be applied and can also be dependent on their location in a structure and the type of illumination striking the surface. Each recommended level of finish is described with typical applications.

TERMINOLOGY

The following definitions are applicable to this document.

Accessories: Metal or plastic beads, trim, or moulding used to protect or conceal corners, edges, or abutments of the gypsum board construction.

Critical Lighting: Strong sidelighting from windows or surface-mounted light fixtures. **syn** severe lighting.

Drywall Primer: A paint material specifically formulated to fill the pores and equalize the suction

difference between gypsum board surface paper and the compound used on finished joints, angles, fastener heads, and accessories and over skim coatings.

Joint Photographing: The shadowing of the finished joint areas through the surface decoration. **syn** telegraphing.

Skim Coat: A thin coat of joint compound, or a material manufactured especially for this purpose, applied over the entire surface to fill imperfections in the joint work, smooth the paper texture, and provide a uniform surface for decorating. Excess compound is immediately sheared off, leaving a film of skim coating compound completely covering the paper.

Spotting: To cover fastener heads with joint compound.

Texture: A decorative treatment of gypsum board surfaces.

Texturing: Regular or irregular patterns typically produced by applying a mixture of joint compound and water, or proprietary texture materials including latex base texture paint, to a gypsum board surface previously coated with primer/sealer.

LEVELS OF FINISH

The following levels of finish are established as a guide for specific final decoration. The minimum requirements for each level shall be as described herein.

LEVEL 0

No taping, finishing, or accessories required.

This level of finish may be useful in temporary construction or whenever the final decoration has not been determined.

LEVEL 1

All joints and interior angles shall have tape set in joint compound. Surface shall be free of excess joint compound. Tool marks and ridges are acceptable.

Frequently specified in plenum areas above ceilings, in attics, in areas

where the assembly would generally be concealed, or in building service corridors, and other areas not normally open to public view. Accessories optional at specifier discretion in corridors and other areas with pedestrian traffic.

Some degree of sound and smoke control is provided; in some geographic areas this level is referred to as "fire-taping." Where a fire-resistance rating is required for the gypsum board assembly, details of construction shall be in accordance with reports of fire tests of assemblies that have met the fire-rating requirement. Tape and fastener heads need not be covered with joint compound.

LEVEL 2

All joints and interior angles shall have tape embedded in joint compound and wiped with a joint knife leaving a thin coating of joint compound over all joints and interior angles. Fastener heads and accessories shall be covered with a coat of joint compound. Surface shall be free of excess joint compound. Tool marks and ridges are acceptable. Joint compound applied over the body of the tape at the time of tape embedment shall be considered a separate coat of joint compound and shall satisfy the conditions of this level.

Specified where water-resistant gypsum backing board (ASTM C 1396) is used as a substrate for tile; may be specified in garages, warehouse storage or other similar areas where surface appearance is not of primary concern.

LEVEL 3

All joints and interior angles shall have tape embedded in joint compound and one additional coat of joint compound applied over all joints and interior angles. Fastener heads and accessories shall be covered with two separate coats of joint compound. All joint compound shall be smooth and free of tool marks and ridges. Note: It

is recommended that the prepared surface be coated with a drywall primer prior to the application of final finishes. See painting/wallcovering specification in this regard.

Typically specified in appearance areas which are to receive heavy- or medium-texture (spray or hand applied) finishes before final painting, or where heavy-grade wallcoverings are to be applied as the final decoration. This level of finish is not recommended where smooth painted surfaces or light to medium wallcoverings are specified.

LEVEL 4

All joints and interior angles shall have tape embedded in joint compound and two separate coats of joint compound applied over all flat joints and one separate coat of joint compound applied over interior angles. Fastener heads and accessories shall be covered with three separate coats of joint compound. All joint compound shall be smooth and free of tool marks and ridges. Note: It is recommended that the prepared surface be coated with a drywall primer prior to the application of final finishes. See painting/wallcovering specification in this regard.

This level should be specified where flat paints, light textures, or wallcoverings are to be applied.

In critical lighting areas, flat paints applied over light textures tend to reduce joint photographing. Gloss, semi-gloss, and enamel paints are not recommended over this level of finish.

The weight, texture, and sheen level of wallcoverings applied over this level of finish should be carefully evaluated. Joints and fasteners must be adequately concealed if the wallcovering material is lightweight, contains limited pattern, has a gloss finish, or any combination of these finishes is present. Unbacked vinyl wallcoverings are not recommended over this level of finish.

LEVEL 5

All joints and interior angles shall have tape embedded in joint compound and two separate coats of joint compound applied over all flat joints and one separate coat of joint compound applied over interior angles. Fastener heads and accessories shall be covered with three separate coats of joint compound. A thin skim coat of joint compound, or a material manufactured especially for this purpose, shall be applied to the entire surface. The surface shall be smooth and free of tool marks and ridges. Note: It is recommended that the prepared surface be coated with a drywall primer prior to the application of finish paint. See painting specification in this regard.

This level of finish is highly recommended where gloss, semi-gloss enamel or nontextured flat paints are specified or where severe lighting conditions occur.

This highest quality finish is the most effective method to provide a uniform surface and minimize the

possibility of joint photographing and of fasteners showing through the final decoration.

COMMENTS

Critical (Severe) Lighting Areas.

Wall and ceiling areas abutting window mullions or skylights, long hallways, or atriums with large surface areas flooded with artificial and/or natural lighting are a few examples of critical lighting areas. Strong sidelighting from windows or surface-mounted light fixtures may reveal even minor surface imperfections. Light striking the surface obliquely, at a very slight angle, greatly exaggerates surface irregularities. If critical lighting cannot be avoided, the effects can be minimized by skim coating the gypsum board surfaces, by decorating the surface with medium to heavy textures, or by the use of draperies and blinds which soften shadows. In general: gloss, semi-gloss, and enamel finishes highlight surface defects; textures hide minor imperfections.

Manufacturer Recommendations.

The recommendations of individual manufacturers of gypsum board, joint tapes and compounds, accessories, drywall primers, wallcoverings, adhesives, texture materials, and paints may vary from what is recommended herein and as such are not a part of this recommended specification.

DRYWALL PRIMER

Applied as a first coat to the entire prepared gypsum board surface with brush, roller, or spray, prior to decoration. Where final appearance is critical, the application of high quality, high solids, drywall primer will minimize most decorating problems.

For finish paints: A good quality, white, latex drywall primer formulated with higher binder solids, applied undiluted, is typically specified for new gypsum board surfaces prior to the application of texture materials and gloss, semi-gloss, and flat latex wall paints.

An alkali and moisture-resistant primer and a tinted enamel undercoat may be required under enamel paints. Consult with the finish paint manufacturer for specific recommendations.

For wallcoverings: White, self-sizing, water base, "universal" (all purpose) wallcovering primers have recently been introduced into the marketplace for use on new gypsum board surfaces. These products are claimed to minimize damage if wallcoverings are subsequently removed, bind poor latex paint, allow hanging over glossy surfaces and existing vinyls, hide wall colors, and to be water washable.

TEXTURING

Texture material is applied by brush, roller, spray, or trowel, or a combination of these tools, depending on the desired result. Textured wall surfaces are normally overpainted with the desired finish; overpainting of textured ceiling surfaces may not be deemed necessary where an adequate amount of material is applied to provide sufficient hiding

NATIONAL GYPSUM JOINT TREATMENT PRODUCTS USED TO ACHIEVE THE LEVELS OF FINISH

	SETTING TYPES			Dry Powder	DRYING TYPES			
	Sta-Smooth				Triple-T	Ready-Mix		
	High Strength	Lite	Regular			All Purpose	Topping Compound	Lite
Level 1 Tape Embedded	•	•	•	•	•		•	•
Level 2 Tape Cover	• •	• •	• •	• •	• •	•	• •	• •
Level 3 Tape Cover Fill Primer	• •	• • •	• •	• • •	• • •	•	• • •	• • •
Level 4 Tape Cover Fill Finish Primer	• •	• • • •	•	• • • •	• • • •	•	• • • •	• • • •
Level 5 Tape Cover Fill Finish Skim Primer	• •	• • • • •	•	• • • • •	• • • • •	•	• • • • •	• • • • •

09 29 00

properties. A drywall primer may not be required under certain proprietary texture materials; consult with the manufacturer of the texture materials for specific recommendations.

Tool, Marks and Ridges. A smooth surface may be achieved by lightly sanding or wiping joint compound with a dampened sponge. Care shall be exercised to ensure that the nap of the gypsum board facing paper is not raised during sanding operations. For additional information on the finishing of gypsum board surfaces consult ASTM Standard C 840.

A Word About Drywall Primer:

The guidelines for these levels of finishing were prepared by AWCI, CISCA, GA and PDCA. The specification describes a drywall primer as "a paint material specifically formulated to fill the pores and equalize the suction difference between gypsum board surface paper and the compound used on finished joints, angles, fastener heads and accessories over skim coatings."



SPECIFICATIONS

SECTION 09 29 00

GYPSUM BOARD

THE FOLLOWING PARAGRAPHS ARE FOR INSERTION INTO SECTIONS OF GENERIC SPECIFICATIONS OR GENERIC/PROPRIETARY SPECIFICATIONS COVERING GYPSUM BOARD PRODUCTS. THE NATIONAL GYPSUM COMPANY PRODUCT NAME FOLLOWS THE GENERIC DESCRIPTION IN PARENTHESES.

PART 1 GENERAL

1.02 REFERENCES

- A. American Society for Testing and Materials (ASTM):
 1. C 840, Specification for Application and Finishing of Gypsum Board.
 2. C 1280, Specification for Application of Gypsum Sheathing Board.
 3. C 1396, Specification for Gypsum Board
 4. C 1629, Standard Classification for Abuse-Resistant Nondecorated Interior Gypsum Panel Products and Fiber-Reinforced Cement Panels.
- B. Gypsum Association (GA):
 1. GA-214, Recommended Specifications: Levels of Gypsum Board Finish.
 2. GA-216, Application and Finishing of Gypsum Panel Products.

PART 2 PRODUCTS

2.02 MATERIALS

- A. Regular Gypsum Board: A gypsum core wall board surfaced with paper on front, back, and long edges and complying with ASTM C 1396 (Gold Bond BRAND Gypsum Board).
 1. Thickness: 1/4", 3/8" or 1/2"
 2. Width: 4'
 3. Length: 6' through 16'
 4. Edges: Square, Tapered, or Beveled Taper (St-Smooth Edge)
- B. Mold-Resistant Gypsum Board: A gypsum core wall panel with additives to enhance the water resistance of the core; surfaced with moisture/mold/mildew-resistant paper on front, back and long edges and complying with ASTM C 1396 (Gold Bond BRAND XP Gypsum Board).
 1. Thickness: 1/2"
 2. Width: 4'
 3. Length: 8, 10' or 12'
 4. Edges: Square or Tapered
 5. Mold and Mildew Resistance: Panel score of 10, when tested in accordance with ASTM D 3273
- C. Fire-Resistant Gypsum Board: A gypsum core wall board with additives to enhance fire resistance of the core and surfaced with paper on front, back, and long edges and complying with ASTM C 1396, Type X.
 1. Thickness: 1/2" (Gold Bond BRAND Fire-Shield C Gypsum Board), 5/8" (Gold Bond BRAND Fire-Shield Gypsum Board), or 5/8" (Gold Bond BRAND Fire-Shield C Gypsum Board).
 2. Width: 4'
 3. Length: 6' through 16' (1/2" Fire-Shield C Gypsum Board, 5/8" Fire-Shield Gypsum Board) Length: 8' through 14' (5/8" Fire-Shield C Gypsum Board)
 4. Edges: Square, Tapered, or Beveled Taper (St-Smooth Edge)

- D. Fire-Resistant Mold-Resistant Gypsum Board: A gypsum core wall panel with additives to enhance the fire resistance of the core and the water resistance of the core; surfaced with a moisture/mold/mildew resistant paper on the front, back and long edges and complying with ASTM C 1396, Type X.
1. Thickness: 1/2" (Gold Bond BRAND XP Fire-Shield C Gypsum Board) 5/8" (Gold Bond BRAND XP Fire-Shield Gypsum Board)
 2. Width: 4'
 3. Length: 8', 10' or 12'
 4. Edges: Square or Tapered
 5. Mold and Mildew Resistance: panel score of 10, when tested in accordance with ASTM D 3273
- E. Fire-Resistant Abuse-Resistant Mold-Resistant Gypsum Board: A gypsum core wall panel with additives to enhance the fire resistance, surface indentation resistance and impact resistance of the core and surfaced with abrasion, moisture/mold/mildew-resistant paper on the front, back and long edges and complying with ASTM C 1396, Type X. (Hi-Abuse BRAND XP Fire-Shield Gypsum Board)
1. Thickness: 5/8"
 2. Width: 4'
 3. Length: 8' through 12'
 4. Edges: Tapered
 5. Surface Abrasion Resistance: Not greater than 0.009" depth when tested at 50 cycles in accordance with ASTM D 4977, Modified.
 6. Indentation Resistance: Not greater than 0.132" depth when tested at an impact load of 72 in.-lbs. in accordance with ASTM D 5420.
 7. Impact/Penetration Resistance: Not less than 210 ft.-lbs. when tested in accordance with ASTM E 695, modified.
 8. Mold and Mildew Resistance: Panel score of 10, when tested in accordance with ASTM D 3273.
- F. Fire-Resistant Impact/Penetration-Resistant Mold-Resistant Gypsum Board: A gypsum core wall panel with additives to enhance the fire resistance, water resistance, surface indentation resistance and impact resistance of the core; surfaced with abrasion, moisture/mold/mildew-resistant paper on the front, back and long edges with a fiberglass mesh embedded in the board to enhance impact/penetration resistance and complying with ASTM C 1396, Type X. (Hi-Impact BRAND XP Fire-Shield Gypsum Board)
1. Thickness: 5/8"
 2. Width: 4'
 3. Length: 8' through 12'
 4. Edges: Tapered
 5. Surface Abrasion Resistance: Not greater than 0.009" depth when tested at 50 cycles in accordance with ASTM D 4977, Modified.
 6. Indentation Resistance: Not greater than 0.114" depth when tested at an impact load of 72 in.-lbs. in accordance with ASTM D 5420.
 7. Impact/Penetration Resistance: Not less than 720 ft.-lbs. when tested in accordance with ASTM E 695, modified.
 8. Mold and Mildew Resistance: Panel score of 10, when tested in accordance with ASTM D 3273.
- G. Gypsum Ceiling Board: A gypsum core ceiling board with additives to enhance the sag resistance of the core and surfaced with paper on front, back, and long edges; and complying with ASTM C 1396 (High Strength BRAND Ceiling Board).
1. Thickness: 1/2"
 2. Width: 4'
 3. Length: 6' through 16'
 4. Edges: Square, Tapered, or Beveled Taper (Sta-Smooth Edge)
- H. Gypsum Sheathing Board: A gypsum core sheathing board with additives to enhance the water resistance of the core; surfaced with water repellent paper on front, back, and long edges; and complying with ASTM C 1396.
1. Regular Board, 4' by 8' or 9' or 10': 1/2" thick with square edge (Gold Bond BRAND Jumbo Gypsum Sheathing).
 2. Fire-Rated Board (Type X): 5/8" thick by 4' wide by 8' or 9' or 10' long with additives in the core to enhance fire resistance (Gold Bond BRAND Fire-Shield Jumbo Gypsum Sheathing).
- I. Fire-Resistant Gypsum Shaftliner Board: A gypsum core shaftwall board with additives to enhance fire resistance of the core and surfaced with water repellent paper on front, back, and long edges and complying with ASTM C 1396, Type X (Gold Bond BRAND Fire-Shield Shaftliner).
1. Thickness: 1"
 2. Width: 2'
 3. Length: 7' through 14'
 4. Edges: Beveled
- J. Fire and Mold-Resistant Gypsum Shaftliner Board: A gypsum core shaftwall board with additives to enhance fire resistance of the core and surfaced with a moisture/mold/mildew resistant paper on front, back, and long edges; and complying with ASTM C 1396, Type X (Gold Bond BRAND Fire-Shield Shaftliner XP).
1. Thickness: 1"
 2. Width: 2'
 3. Length: 7' through 14'
 4. Edges: Beveled
 5. Mold and Mildew Resistance: Panel score of 10, when tested in accordance with ASTM D 3273
- K. Exterior Gypsum Soffit Board: A gypsum core soffit board with additives to enhance the sag resistance of the core; surfaced with water repellent paper on front, back, and long edges; and complying with ASTM C 1396 (Gold Bond BRAND Exterior Soffit Board).
1. Thickness: 1/2"
 2. Width: 4'
 3. Length: 8' through 12'
 4. Edges: Beveled Taper (Sta-Smooth Edge)
- L. Fire-Resistant Exterior Gypsum Soffit Board: A gypsum core soffit board with additives to enhance the fire resistance and the sag resistance of the core; surfaced with water repellent paper on front, back, and long edges; and complying with ASTM C 1396, Type X (Gold Bond BRAND Fire-Shield Exterior Soffit Board).
1. Thickness: 5/8"
 2. Width: 4'
 3. Length: 8' through 12'
 4. Edges: Beveled Taper (Sta-Smooth Edge)

- M. Flexible Gypsum Board: A gypsum core wall panel with additives to enhance flexibility surfaced with paper on front, back and long edges and complying with ASTM C 1396 (High Flex BRAND Gypsum Board).
1. Thickness: 1/4"
 2. Width: 4'
 3. Length: 8' through 12'
 4. Edges: Slightly Tapered
- N. Fire-Resistant Vinyl laminated Gypsum Grid Board: A gypsum core lay-in ceiling panel with additives to enhance the sag and fire resistance of the core; surfaced with paper on the front and back and finished on the front with a 2-mil, white, stipple textured vinyl laminate; and complying with ASTM C 1396, Type X, Class 1; E 1264 Type XX, patterns E, G (Gridstone BRAND Ceiling Panel).
1. Thickness: 1/2"
 2. Width and Length: 2' x 2' and 2' x 4'
 3. Edges: Square
- O. Fire-Resistant Sealed Vinyl Laminated Gypsum Grid Board: A gypsum core lay-in ceiling panel with additives to enhance the sag and fire resistance of the core and sealed on face, back and long edges with a 2-mil rigid vinyl film, exposed edges are factory sealed with a durable coating providing a completely sealed panel; and complying with ASTM C 1396, Type X, Class 1, E 1264, Type XX, patterns E, G (Gridstone BRAND CleanRoom Ceiling Panel).
1. Thickness: 1/2"
 2. Width and Length: 2' x 2' and 2' x 4'
 3. Edges: Square
- P. Vinyl Laminated Gypsum Grid Board: A gypsum core lay-in ceiling panel with additives to enhance the sag resistance of the core; surfaced with paper on the front and back and finished on the front with a 2-mil, white, stipple textured vinyl laminate; and complying with ASTM C 1396, Class 1, E 1264, Type XX, patterns E, G (Gridstone BRAND Hi-Strength Ceiling Panel).
1. Thickness: 5/16"
 2. Width and Length: 2' x 2' and 2' x 4'
 3. Edges: Square
- Q. Joint Treatment:
1. Tape: 2 1/16" wide paper reinforcing tape (ProForm BRAND Joint Tape).
 2. Tape: 2" wide paper reinforcing tape with metal strips laminated along the center crease to form inside and outside corners (ProForm BRAND Multi-Flex Tape Bead).
 3. Tape: 2" wide self-adhering fiberglass tape (ProForm BRAND Fiberglass MeshTape).
4. Compound: Drying type pre-mixed compound (ProForm BRAND Multi-Use Joint Compound, ProForm BRAND All Purpose Joint Compound, regular grade and machine grade, ProForm BRAND Lite Joint Compound, ProForm BRAND Ultra Joint Compound, ProForm BRAND XP Joint Compound and ProForm BRAND Taping Joint Compound).
 5. Compound: Drying type job mixed vinyl base compound (ProForm BRAND Triple-T Compound).
 6. Compound: Drying type vinyl base topping compound, pre-mixed (ProForm BRAND Topping Joint Compound).
 7. Compound: Setting type job mixed chemical-hardening compound (ProForm BRAND Sta-Smooth Joint Compound, ProForm BRAND Sta-Smooth Lite Joint Compound, and ProForm BRAND Sta-Smooth HS Joint Compound).
- R. Textured Coatings:
1. Ceiling Coating: Compound of minerals and clays for mixing with a mineral or polystyrene aggregate and water (ProForm Brand Perfect Spray Texture.)
 2. Wall Coating: Compound of minerals and clays for mixing with water (ProForm BRAND Perfect Spray EM Texture).

PART 3 EXECUTION

3.01 INSTALLATION

- A. General: In accordance with ASTM C 840 and manufacturer's recommendations, "National Gypsum Construction Guide."



For additional information
 Phone **1-800-NATIONAL**
(1-800-628-4662)

Cavity Shaftwall Systems



09 21 16.23

CAVITY SHAFTWALL SYSTEMS

DESCRIPTION

Gypsum drywall shaft construction has become the preferred alternative to traditional masonry shafts. One-inch Shaftliner board was developed as a lightweight, easy-to-install replacement for masonry in the interior core of buildings for shaftwalls, stairwells, other vertical chases and mechanical enclosures. Shaftliner board is also used as a component of 2" solid partitions, and area separation walls with a layer of 1/2" Regular or Fire-Shield Gypsum Board attached to each side.

Historically, heavy masonry weighing 20 to 45 lbs. per square foot was used for shaftwall construction. With the use of Shaftliner, shaftwall assemblies weigh in at a remarkably low 10 to 13 lbs. per square foot.

The benefits of gypsum drywall shaft systems go far beyond the difference in weight alone. The core wall of a shaft can be installed from the exterior of the shaft and requires no scaffolding. Erection is speedy and clean. Shaftliner also provides excellent sound control and can achieve the fire ratings necessary for today's building construction. Best of all, gypsum shaftwall systems are more economical than masonry shaft construction.

National Gypsum produces Shaftliner board with green moisture-resistant paper or purple moisture/mold/mildew resistant paper on both sides with a beveled edge configuration allowing for simple installation into the Shaftwall System framing.

Cavity Shaftwall systems are a nonload-bearing drywall partition made up of two basic components, gypsum board and metal framing. Gypsum board includes 1" Fire-Shield Shaftliner or 1" Fire-Shield Shaftliner XP panels, 1/2" Fire-Shield C

and 5/8" Fire-Shield Gypsum Board face panels. 1/2" XP Fire-Shield C or 5/8" XP Fire-Shield Gypsum Board face panels may be utilized for extra protection against mold and mildew. The framing includes I-Studs, C-T Studs and C-H studs with integral tabs/flange which hold the panels in place and J Track for runners at top and bottom, as well as vertically at partition ends and to frame openings.

The Cavity Shaftwall Systems were developed to enclose elevator shafts and other vertical chases in buildings where it is advantageous to erect these walls from one side only and where fire resistance and resistance to air pressures are required.

National Gypsum Company Cavity Shaftwall Systems may be constructed with C-T, C-H or I-Stud shaftwall framing.

Lightweight. Cavity Shaftwall Systems are very lightweight compared to conventional shaftwalls, weighing approximately 10 lbs. per sq. ft. of wall when finished with two layers of 1/2" Fire-Shield C Gypsum Board.

Economical. Shafts can be quickly enclosed with shaftwall framing and Shaftliner under most conditions in which installers can work, well below temperature limitations for finish gypsum board applications.

Practical. The 1" Shaftliner is faced with light green moisture-resistant paper and Shaftliner XP is faced with purple moisture/mold/mildew resistant paper for protection against weather during installation.

I-Stud Code Report References:

ICC ES, Inc. Legacy Report 89-35.01

ICC ES, Inc. Legacy Report 9525B

ICBO ES, ER-3579

Note: In addition to National Gypsum systems, 1/2" Fire-Shield C, 5/8" Fire-Shield and 1" Fire-Shield Shaftliner panels are listed in Dietrich Industries ICC ES Legacy Report NER-506, Shaftwall and Stairwell Fire-Resistive (C-T stud) Assemblies.

TECHNICAL DATA

FUNCTION AND UTILITY

Loading Performance.

Although the cavity shaftwall systems are non-load-bearing, this System has been designed and tested to withstand positive and negative air pressure forces exerted by high-speed, high-rise elevators.

Fire Resistance. The cavity shaftwall systems have been fire tested and have achieved fire resistance ratings of 1 and 2 hours. All components are noncombustible. Refer to pages 19 and 20.

25 GA (.020" minimum steel thickness) J Track exceeded 2,000,000 lateral load oscillation cycles in a test conducted to duplicate the positive and negative pressures created as elevator cabs rise and descend in a shaft.

Sound Transmission. STC ratings of 40 to 51 have been achieved in tests conducted in accordance with ASTM E 90. Refer to pages 19 and 20.

LIMITATIONS

1. Nonload-bearing.
2. The cavity shaftwall systems should not be used where exposed to constant dampness or conditions under which free water can be formed.
3. This System should not be exposed to temperatures over 125° F for extended periods of time.
4. Where reference is made to nominal gauges, 25 gauge relates to minimum base steel of .020" and 20 gauge to .0329".

I-STUD SECTION PROPERTIES ABOUT X-X AXIS

A= Section Area, in.²

Y= Distance from neutral axis to extreme steel fiber, in.

I = Moment of Inertia, in.⁴

S= Section Modulus, in.³

Section properties based on steel without galvanizing.

Stud Size	Min. Base Steel	A	Y	I	S
2 1/2" (63.5 mm)	0.020"	0.133	1.366	0.151	0.110
2 1/2" (63.5 mm)	0.0329"	0.253	1.262	0.288	0.228
4" (102 mm)	0.020"	0.163	2.152	0.421	0.196
4" (102 mm)	0.0329"	0.307	2.016	0.822	0.408
6" (152 mm)	0.0329"	0.342	3.020	1.860	0.616

Above properties are in accordance with AISI "Specifications For the Design of Cold-Formed Steel Structural Members."

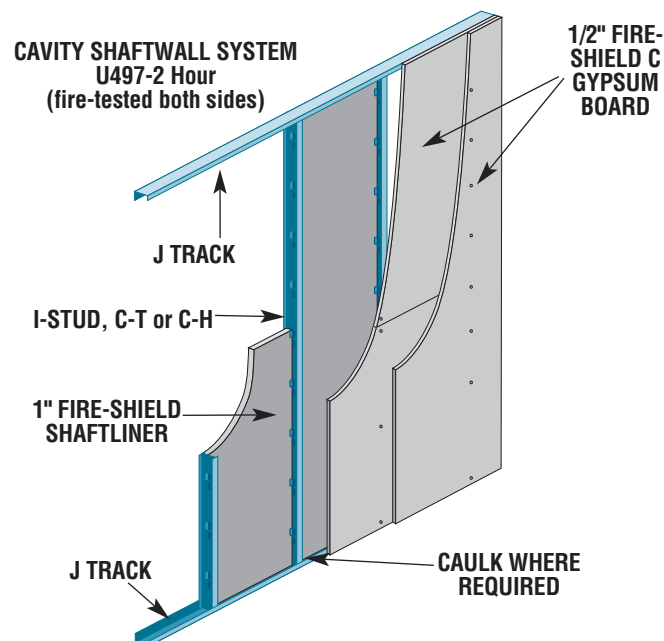

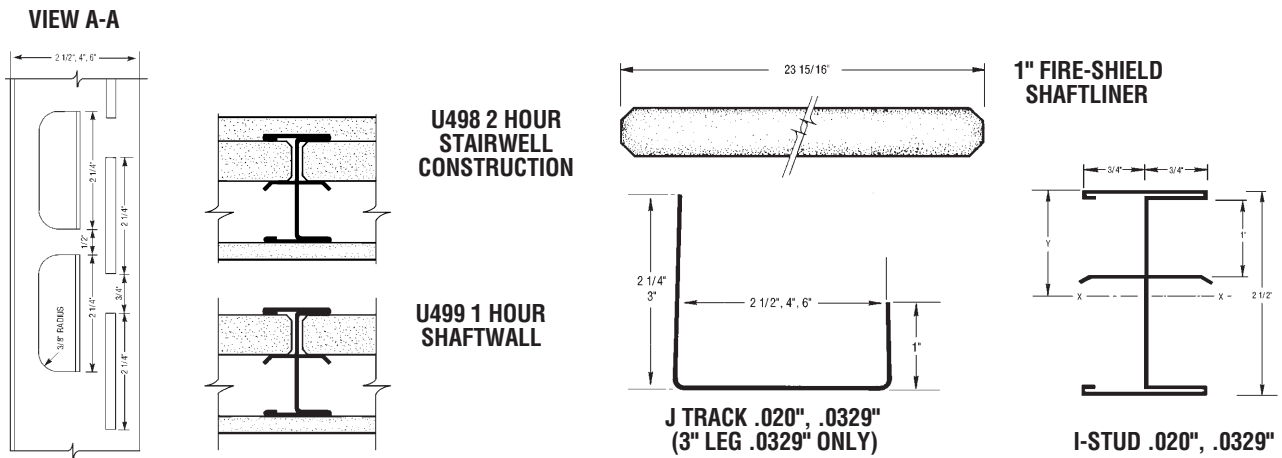

ALLOWABLE WALL HEIGHTS FOR 1-HOUR FIRE-RATED I-STUD ASSEMBLIES

Stud Size in. (mm)	Stud Spacing in. O.C. (mm)	Min. Steel Thickness in.	Allowable Deflection	Sustained Air Pressure Load PSF			
				5	7.5	10	15
2 1/2" (63.5 mm)	24" (610 mm)	0.020	L/120	13'- 4" (4060 mm)	11'- 7" (3531 mm)	10'- 1" (3073 mm)	8'- 3" (2515 mm)
			L/240	10'- 7" (3226 mm)	9'- 3" (2819 mm)	8'- 4" (2515 mm)	7'- 4" (2235 mm)
			L/360	9'- 3" (2819 mm)	8'- 1" (2464 mm)	7'- 4" (2235 mm)	6'- 5" (1956 mm)
2 1/2" (63.5 mm)	24" (610 mm)	0.0329	L/120	15'- 2" (4623 mm)	13'- 3" (4039 mm)	12'- 1" (3683 mm)	10'- 7" (3226 mm)
			L/240	12'- 1" (3683 mm)	10'- 7" (3226 mm)	9'- 7" (2921 mm)	8'- 4" (2540 mm)
			L/360	10'- 7" (3226 mm)	9'- 2" (2794 mm)	8'- 4" (2540 mm)	7'- 4" (2235 mm)
4" (102 mm)	24" (610 mm)	0.020	L/120	17'- 11" (5461 mm)	14'- 10" (4521 mm)	12'- 10" (3912 mm)	9'- 9" (2972 mm)
			L/240	14'- 3" (4343 mm)	12'- 5" (3785 mm)	11'- 4" (3454 mm)	9'- 5" (2870 mm)
			L/360	12'- 5" (3785 mm)	10'- 10" (3302 mm)	9'- 5" (2870 mm)	8'- 3" (2515 mm)
4" (102 mm)	24" (610 mm)	0.0329	L/120	20'- 0" (6096 mm)	18'- 2" (5537 mm)	16'- 6" (5029 mm)	14'- 3" (4343 mm)
			L/240	16'- 6" (5029 mm)	14'- 5" (4394 mm)	13'- 1" (3988 mm)	11'- 5" (3480 mm)
			L/360	14'- 5" (4394 mm)	12'- 7" (3835 mm)	11'- 5" (3480 mm)	9'- 4" (2845 mm)
6" (152 mm)	24" (610 mm)	0.0329	L/120	24'- 0" (7315 mm)	22'- 10" (6960 mm)	19'- 9" (6020 mm)	16'- 2" (4928 mm)
			L/240	20'- 11" (6375 mm)	18'- 4" (5588 mm)	16'- 8" (5080 mm)	14'- 6" (4420 mm)
			L/360	18'- 4" (5588 mm)	16'- 0" (4877 mm)	14'- 6" (4420 mm)	10'- 11" (3327 mm)

>Yield strength 40,000 psi
Limiting heights are based on transverse load tests (in accordance with ASTM E 72) and calculated utilizing the loads indicated.

ALLOWABLE WALL HEIGHTS FOR 2-HOUR FIRE-RATED I-STUD ASSEMBLIES UNLINED RETURN AIR SHAFTS

Stud Size in. (mm)	Stud Spacing in. O.C. (mm)	Min. Steel Thickness in.	Allowable Deflection	Sustained Air Pressure Load PSF			
				5	7.5	10	15
2 1/2" (63.5 mm)	24" (610 mm)	0.020	L/120	14'- 7" (4445 mm)	12'- 4" (3759 mm)	10'- 9" (3277 mm)	8'- 9" (2667 mm)
			L/240	11'- 7" (3531 mm)	10'- 1" (3073 mm)	9'- 2" (2794 mm)	8'- 0" (2438 mm)
			L/360	10'- 1" (3073 mm)	8'- 10" (2692 mm)	8'- 0" (2438 mm)	7'- 0" (2134 mm)
2 1/2" (63.5 mm)	24" (610 mm)	0.0329	L/120	17'- 9" (5410 mm)	15'- 6" (4724 mm)	14'- 1" (4293 mm)	12'- 4" (3759 mm)
			L/240	14'- 1" (4293 mm)	12'- 4" (3759 mm)	11'- 2" (3404 mm)	8'- 9" (3404 mm)
			L/360	12'- 4" (3759 mm)	9'- 8" (2946 mm)	8'- 9" (2667 mm)	7'- 8" (2337 mm)
4" (102 mm)	24" (610 mm)	0.020	L/120	19'- 10" (6045 mm)	16'- 3" (4953 mm)	14'- 0" (4267 mm)	10'- 2" (3099 mm)
			L/240	16'- 2" (4928 mm)	14'- 2" (4318 mm)	11'- 6" (3505 mm)	10'- 0" (3048 mm)
			L/360	14'- 2" (4318 mm)	11'- 0" (3353 mm)	10'- 0" (3048 mm)	8'- 9" (2667 mm)
4" (102 mm)	24" (610 mm)	0.0329	L/120	23'- 2" (7061 mm)	20'- 2" (6147 mm)	18'- 1" (5512 mm)	14'- 9" (4496 mm)
			L/240	18'- 4" (5588 mm)	16'- 1" (4902 mm)	14'- 7" (4445 mm)	11'- 1" (3378 mm)
			L/360	16'- 1" (4902 mm)	14'- 0" (4267 mm)	11'- 1" (3378 mm)	9'- 8" (2946 mm)
6" (152 mm)	24" (610 mm)	0.0329	L/120	28'- 0" (8534 mm)	23'- 11" (7290 mm)	20'- 9" (6325 mm)	16'- 11" (5156 mm)
			L/240	22'- 9" (6934 mm)	19'- 10" (6045 mm)	18'- 0" (5486 mm)	12'- 10" (3912 mm)
			L/360	19'- 10" (6045 mm)	17'- 4" (5283 mm)	12'- 10" (3912 mm)	11'- 2" (3404 mm)

>Yield strength 40,000 psi
Limiting heights are based on transverse load tests (in accordance with ASTM E 72) and calculated utilizing the loads indicated.

09 21 16.23

ALLOWABLE WALL HEIGHTS FOR 2-HOUR FIRE-RATED I-STUD ASSEMBLIES STAIRWELLS

Stud Size in. (mm)	Stud Spacing in. O.C. (mm)	Min. Steel Thickness in.	Allowable Deflection	Sustained Air Pressure Load PSF			
				5	7.5	10	15
2 1/2" (63.5 mm)	24" (610 mm)	0.020	L/120	13'- 11" (4242 mm)	12'- 2" (3708 mm)	11'- 0" (3353 mm)	9'- 8" (2946 mm)
			L/240	11'- 0" (3353 mm)	9'- 8" (2946 mm)	8'- 9" (3404 mm)	7'- 8" (2337 mm)
			L/360	8'- 9" (2946 mm)	8'- 5" (2565 mm)	7'- 8" (2337 mm)	6'- 8" (2032 mm)
2 1/2" (63.5 mm)	24" (610 mm)	0.0329	L/120	16'- 7" (5055 mm)	14'- 6" (4420 mm)	13'- 2" (4013 mm)	11'- 6" (3505 mm)
			L/240	13'- 2" (4013 mm)	11'- 6" (3505 mm)	9'- 10" (2897 mm)	8'- 7" (2616 mm)
			L/360	11'- 6" (3505 mm)	10'- 0" (3048 mm)	8'- 7" (2616 mm)	7'- 6" (2286 mm)
4" (102 mm)	24" (610 mm)	0.020	L/120	20'- 2" (6147 mm)	17'- 8" (5385 mm)	16'- 0" (4877 mm)	11'- 11" (3632 mm)
			L/240	16'- 0" (4877 mm)	11'- 11" (3632 mm)	10'- 10" (3302 mm)	9'- 5" (2870 mm)
			L/360	11'- 11" (3632 mm)	10'- 6" (3175 mm)	9'- 5" (2870 mm)	8'- 3" (2515 mm)
4" (102 mm)	24" (610 mm)	0.0329	L/120	22'- 3" (6782 mm)	19'- 6" (5944 mm)	17'- 8" (5385 mm)	15'- 6" (4724 mm)
			L/240	17'- 8" (5385 mm)	15'- 6" (4724 mm)	14'- 1" (4293 mm)	10'- 8" (3251 mm)
			L/360	15'- 6" (4724 mm)	11'- 9" (3581 mm)	10'- 8" (3251 mm)	9'- 4" (2845 mm)
6" (152 mm)	24" (610 mm)	0.0329	L/120	28'- 0" (8534 mm)	24'- 10" (7569 mm)	22'- 7" (6883 mm)	19'- 9" (6020 mm)
			L/240	22'- 7" (6883 mm)	19'- 9" (6020 mm)	17'- 11" (5461 mm)	12'- 3" (3734 mm)
			L/360	19'- 9" (6020 mm)	13'- 6" (4115 mm)	12'- 3" (3734 mm)	10'- 9" (3277 mm)

› Yield strength 40,000 psi
 Limiting heights are based on transverse load tests (in accordance with ASTM E 72)
 and calculated utilizing the loads indicated.

ALLOWABLE WALL HEIGHTS FOR 2-HOUR FIRE-RATED I-STUD ASSEMBLIES

Stud Size in. (mm)	Stud Spacing in. O.C. (mm)	Min. Steel Thickness-in.	Allowable Deflection	Intermittent Air Pressure Load PSF			
				5	7.5	10	15
2 1/2" (63.5 mm)	24 (610 mm)	0.020	L/120	15'- 3" (4648 mm)	12'- 6" (3810 mm)	10'- 9" (3276 mm)	8'- 10" (2692 mm)
			L/240	12'- 6" (3810 mm)	11'- 0" (3352 mm)	10'- 0" (3048 mm)	8'- 9" (2667 mm)
			L/360	11'- 0" (3352 mm)	9'- 6" (2895 mm)	8'- 8" (2641 mm)	7'- 7" (2311 mm)
2 1/2" (63.5 mm)	24 (610 mm)	0.0329	L/120	17'- 10" (5435 mm)	15'- 8" (4775 mm)	14'- 2" (4318 mm)	*12'- 5" (3784 mm)
			L/240	14'- 2" (4318 mm)	12'- 5" (3784 mm)	11'- 4" (3454 mm)	9'- 10" (2997 mm)
			L/360	12'- 5" (3784 mm)	10'- 11" (3327 mm)	9'- 10" (2997 mm)	8'- 7" (2616 mm)
4 (102 mm)	24 (610 mm)	0.020	L/120	20'- 4" (6197 mm)	16'- 8" (5080 mm)	*14'- 5" (4394 mm)	*11'- 10" (3606 mm)
			L/240	16'- 1" (4902 mm)	14'- 1" (4292 mm)	12'- 10" (3911 mm)	*11'- 2" (3403 mm)
			L/360	14'- 1" (4292 mm)	12'- 4" (3759 mm)	11'- 2" (3403 mm)	*9'- 10" (2997 mm)
4 (102 mm)	24 (610 mm)	0.0329	L/120	21'- 10" (4114 mm)	*19'- 1" (5816 mm)	*17'- 4" (5283 mm)	*15'- 1" (4597 mm)
			L/240	17'- 4" (5283 mm)	15'- 1" (4597 mm)	13'- 10" (4216 mm)	*12'- 0" (3657 mm)
			L/360	15'- 1" (4597 mm)	13'- 2" (4013 mm)	12'- 0" (3657 mm)	*10'- 6" (3200 mm)
6 (152 mm)	24 (610 mm)	0.0329	L/120	25'- 4" (7721 mm)	*22'- 1" (6731 mm)	*20'- 1" (6121 mm)	*17'- 6" (5334 mm)
			L/240	20'- 1" (6121 mm)	*17'- 6" (5334 mm)	*15'- 11" (4851 mm)	*13'- 11" (4241 mm)
			L/360	17'- 6" (5334 mm)	15'- 4" (4673 mm)	13'- 11" (4241 mm)	*12'- 2" (3708 mm)

f Limited by bending stress
 v Limited by end reaction relating to stud or track
 * 20 gauge track required

› Yield strength 40,000 psi
 › Unless noted, heights are limited by deflection.
 › For heights limited by bending stress, allowable bending stresses have been increased by 33.33% for intermittent loading.
 › Heights limited by deflection are based on transverse load tests (in accordance with ASTM E 72) and calculated utilizing the loads indicated.

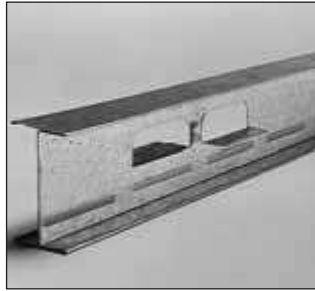

SHAFTWALL STUD
Used with J Track for framing Cavity Shaftwalls. Tabs retain 1" shaftliner. Galvanized steel.

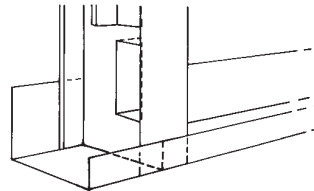

J TRACK
2 1/4" Leg.
Used with I-Stud for framing Cavity Shaftwalls. Galvanized steel.

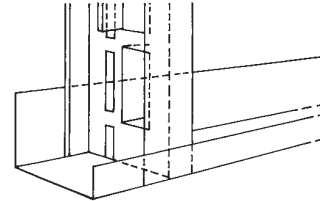

DETAILS

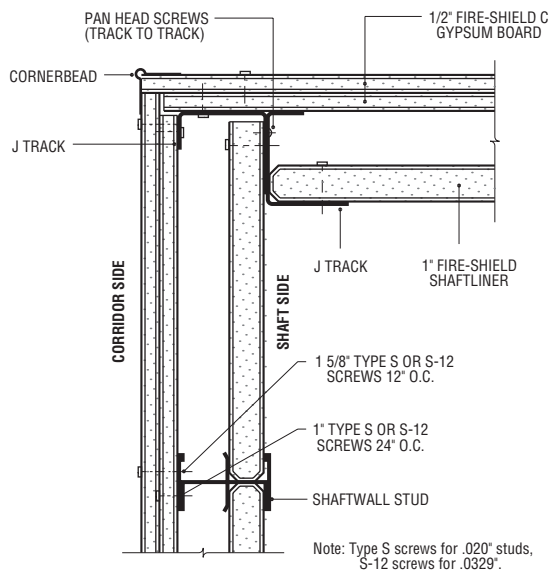

OUTSIDE CORNER
09260C
Scale: 2 1/4" = 1'-0"

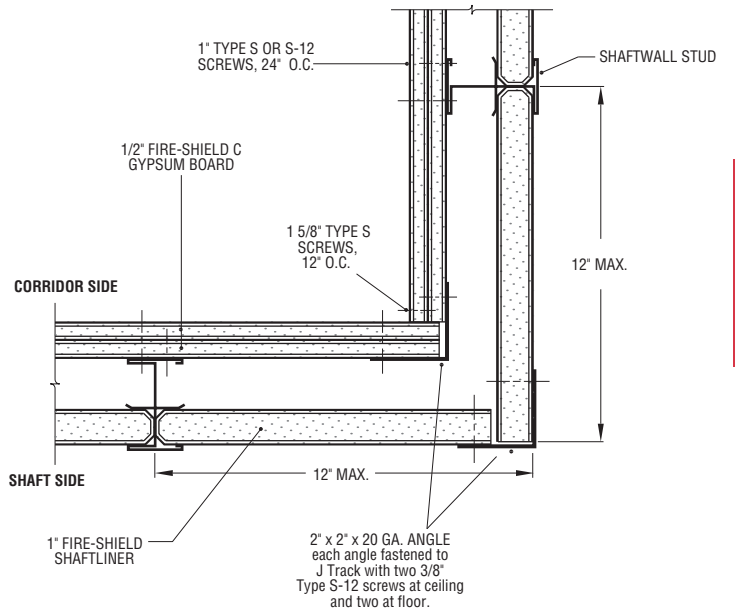

INSIDE CORNER
09260D
Scale: 2 1/4" = 1'-0"

09 21 16.23

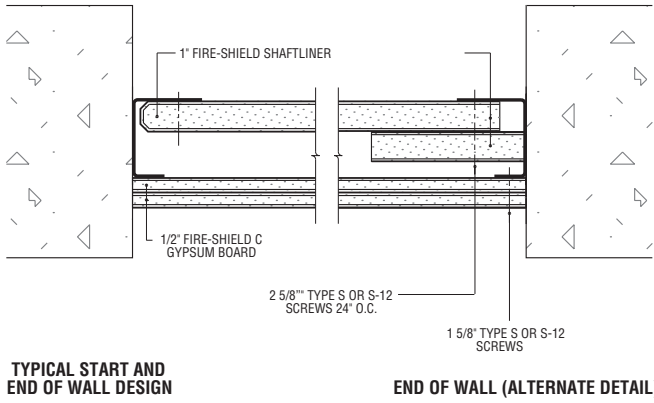

**TYPICAL START AND
END OF WALL DESIGN**

09260B
Scale: 2 1/4" = 1'-0"

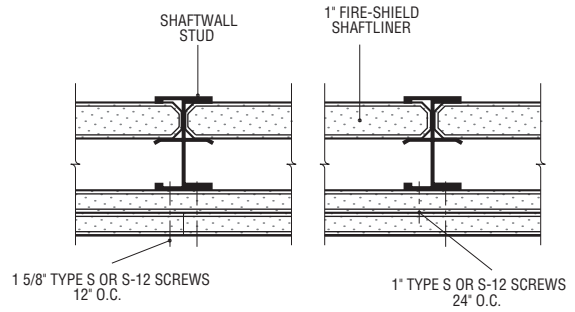

TYPICAL SECTION

09260A
Scale: 2 1/4" = 1'-0"

7' Elevator Door Frames

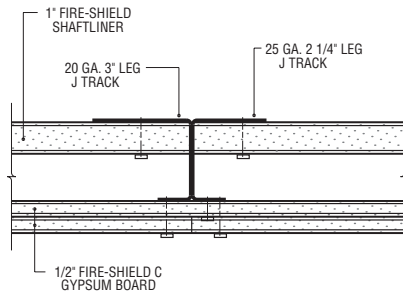

**SHAFTWALL J TRACK FRAMING ABOVE 7'-0"
ELEVATOR DOOR
(Section C-C)**

09260G
Scale: 2 1/4" = 1'-0"

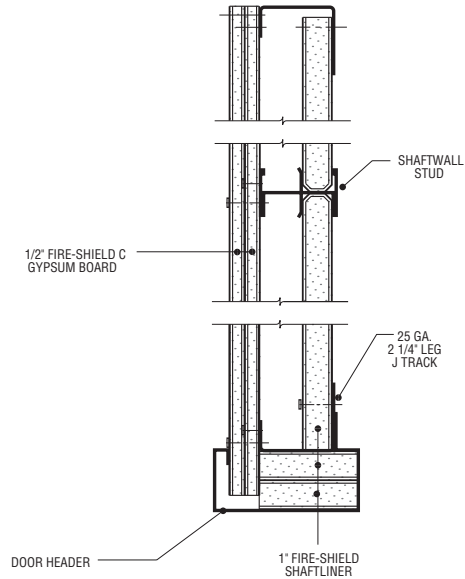

**SHAFTWALL ELEVATOR DOOR HEAD
(Section B-B)**

09260H
Scale: 2 1/4" = 1'-0"

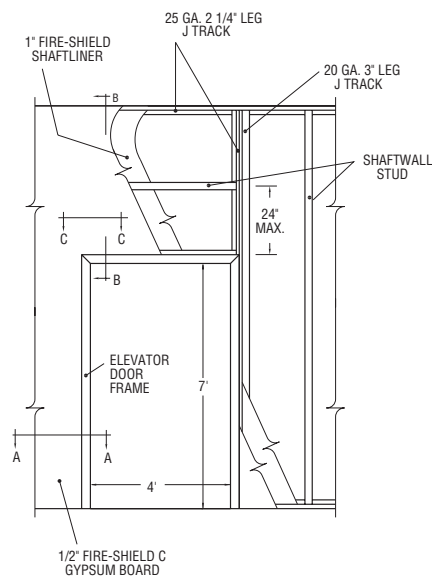

SHAFTWALL FRAMING FOR ELEVATOR DOOR UP TO 7'-0"

09260E
Scale: 1/4" = 1'-0"

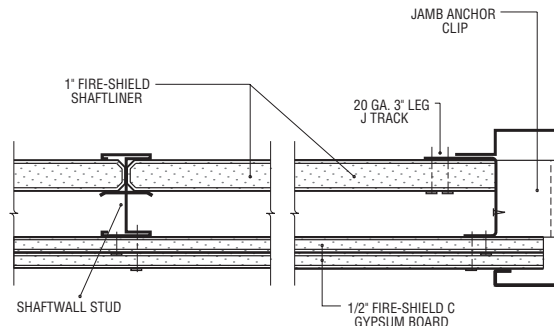

**SHAFTWALL 7'-0" ELEVATOR DOOR JAMB
(Section A-A)**

09260F
Scale: 2 1/4" = 1'-0"

Elevator Door Frames Over 7'

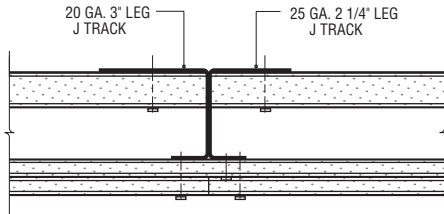

SHAFTWALL J TRACK FRAMING ABOVE ELEVATOR DOOR (Section F-F)

09260K
Scale: 2 1/4" = 1'-0"

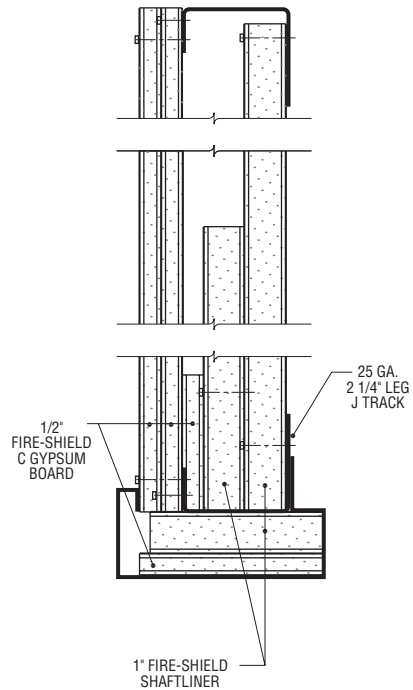

SHAFTWALL ELEVATOR DOOR HEAD (Section E-E)

09260L
Scale: 3" = 1'-0"

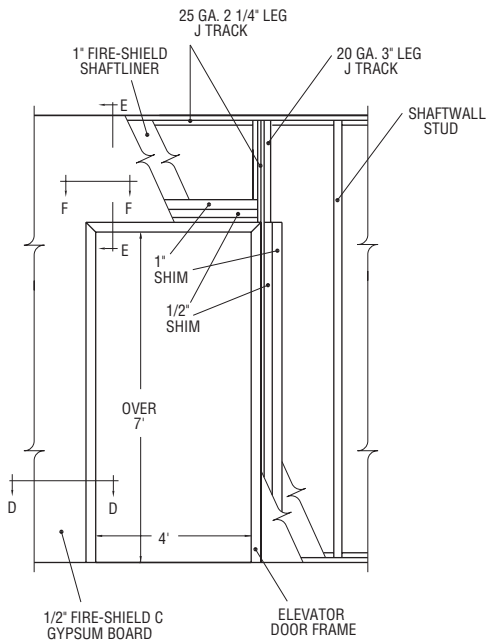

SHAFTWALL FRAMING FOR ELEVATOR DOOR OVER 7'-0"

09260I
Scale: 1/4" = 1'-0"

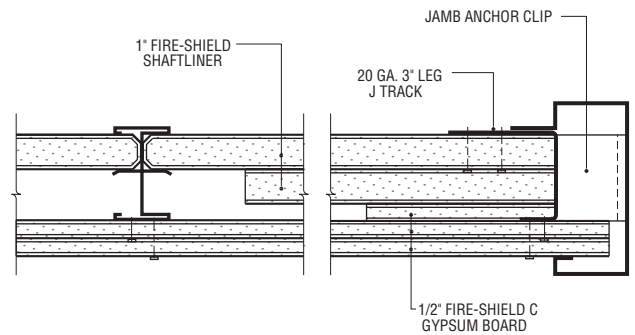

SHAFTWALL ELEVATOR DOOR JAMB (Section D-D)

09260J
Scale: 2 1/4" = 1'-0"

09 21 16.23

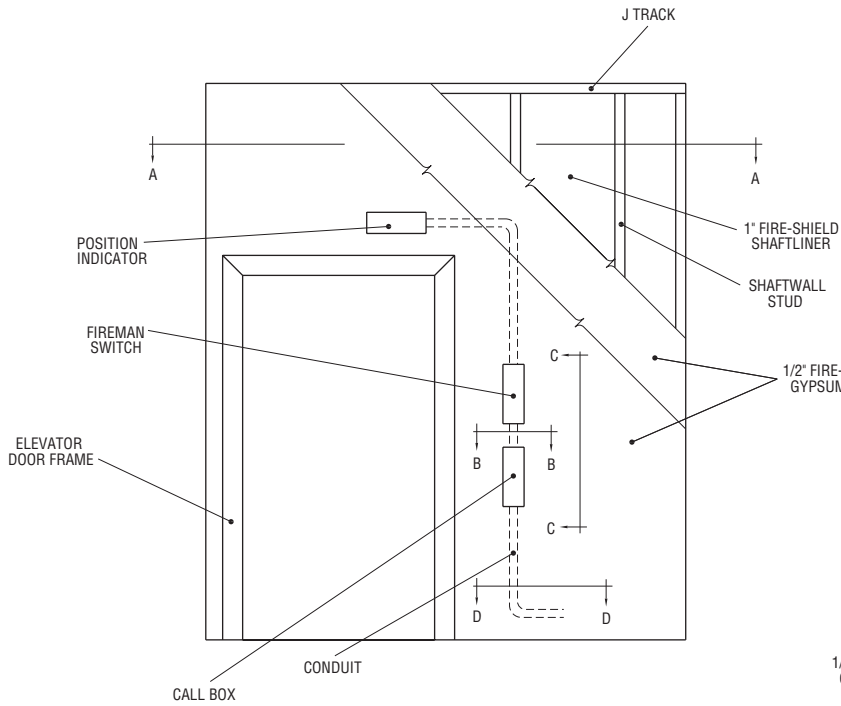

SHAFTWALL ELEVATOR ELECTRICAL CONTROL LAYOUT

09260Z
Scale: 1/4" = 1'-0"

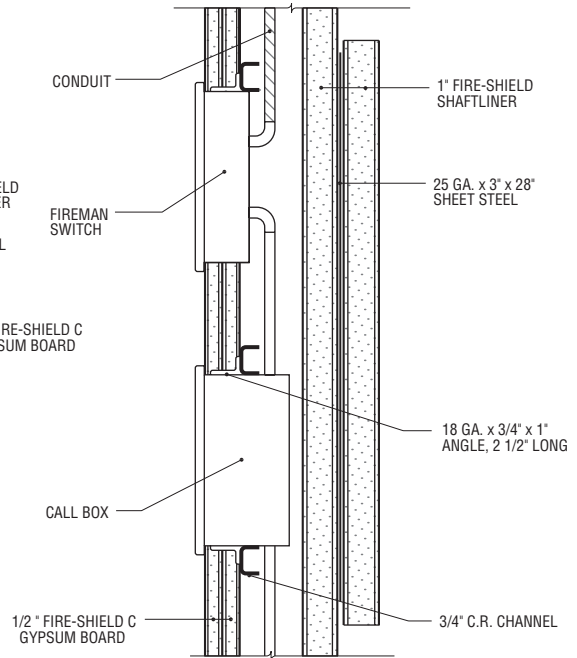

**SHAFTWALL FIREMAN SWITCH AND CALL BOX
(Section CC)**

09260AA
Scale: 2 1/4" = 1'-0"

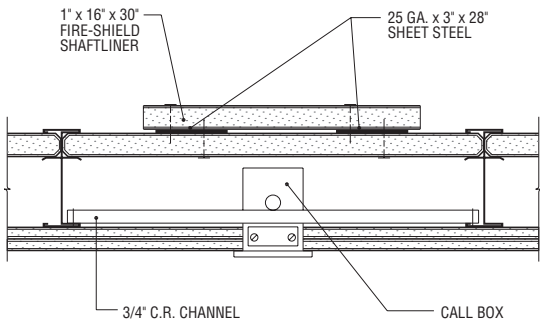

**SHAFTWALL CALL BOX
(Section BB)**

09260BB
Scale: 1 1/2" = 1'-0"

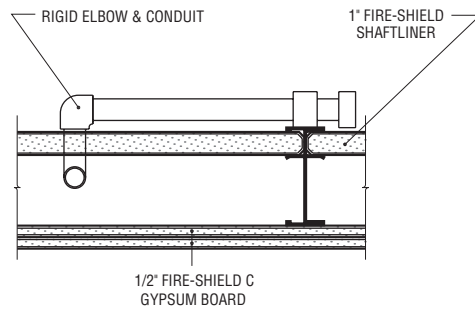

**SHAFTWALL WITH CONDUIT
(Section DD)**

09260CC
Scale: 1 1/2" = 1'-0"

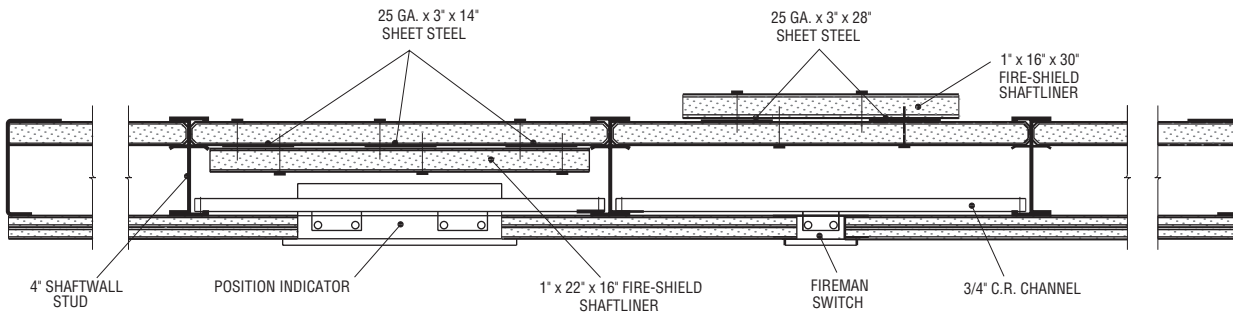

**SHAFTWALL FIREMAN SWITCH AND INDICATOR BOX
(Section AA)**

09260DD
Scale: 1 1/2" = 1'-0"

NOTE: These assemblies tested Factory Mutual
Design WP 621 and Factory Mutual WP 612

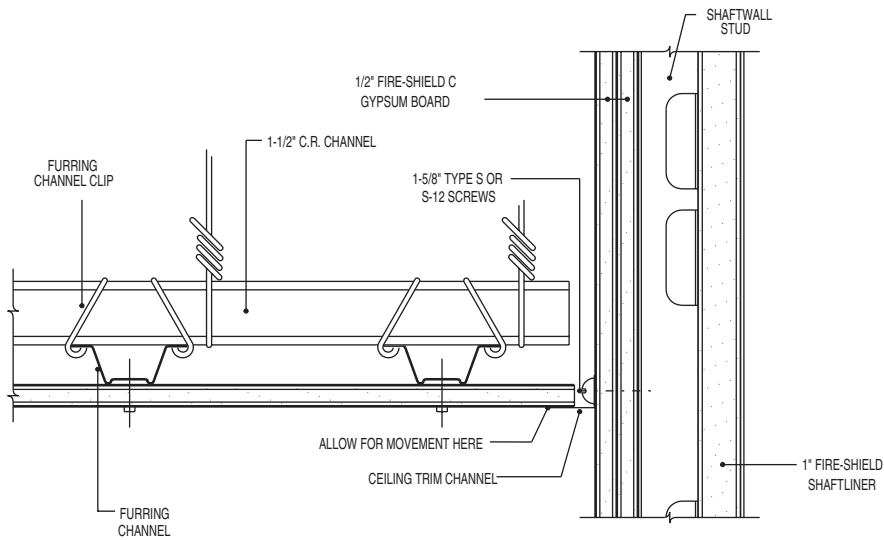

SHAFTWALL AT SUSPENDED CEILING

(UNRESTRAINED)

09260M

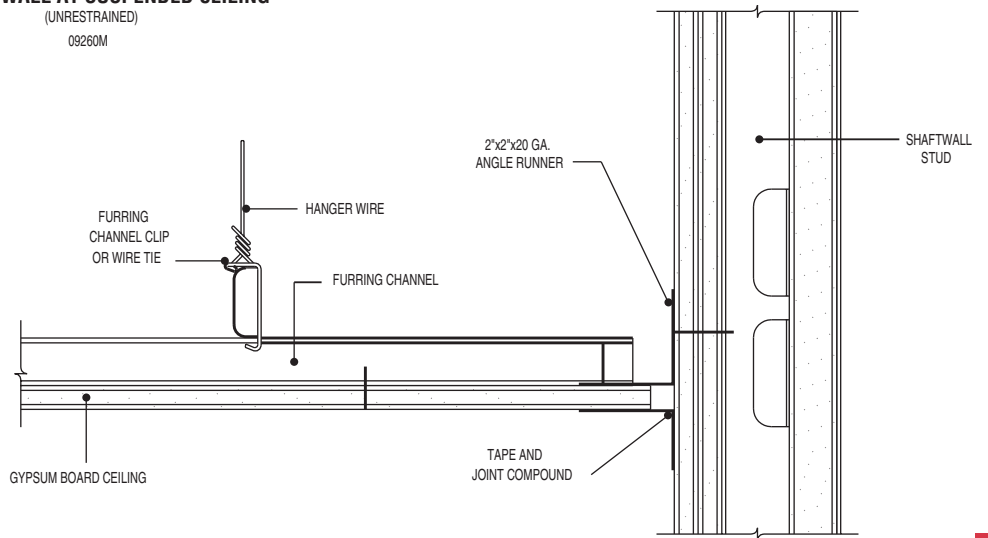

SHAFTWALL AT SUSPENDED CEILING

(RESTRAINED)

09260N

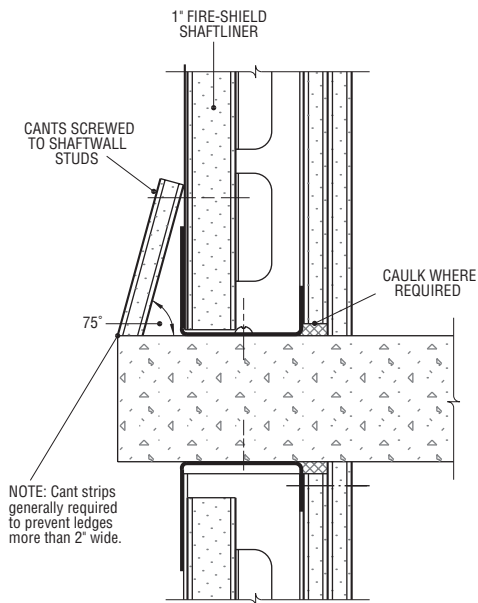

SHAFT CANTS

09260P

Scale: 3" = 1'-0"

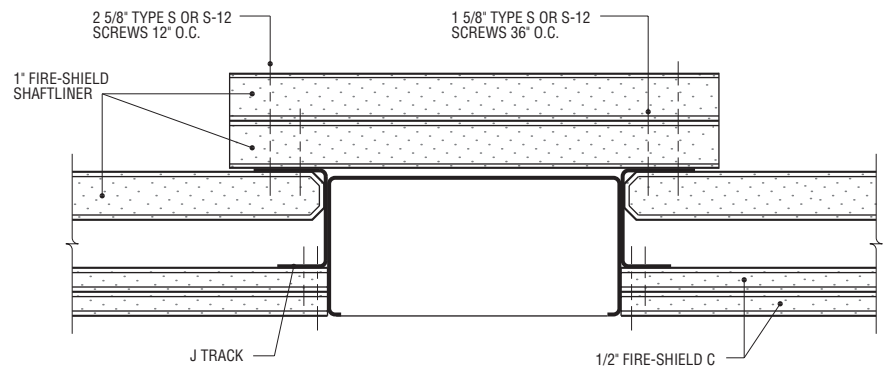

MAIL CHUTE

092600

Scale: 3" = 1'-0"

09 21 16.23

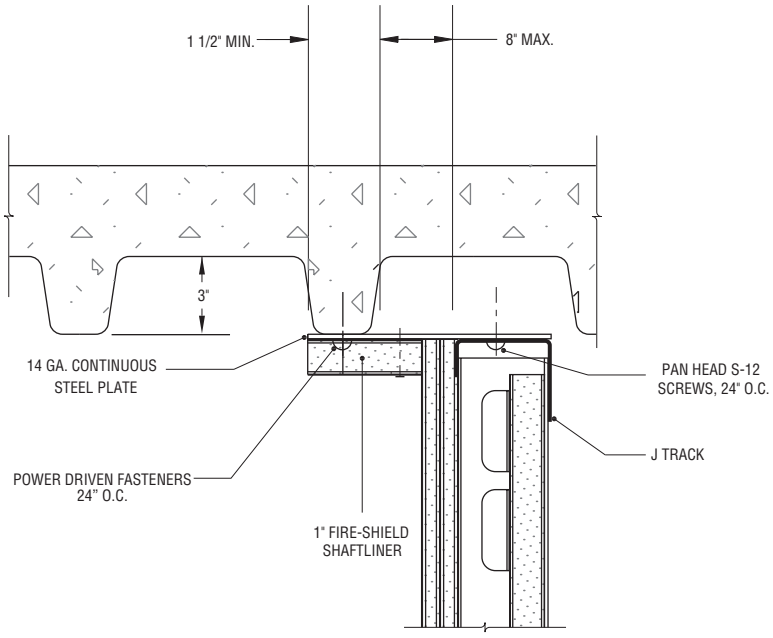

**STUD CAVITY WALL
PARALLEL TO DECK VALLEYS**

09260Q
Scale: 2 1/4" = 1'-0"

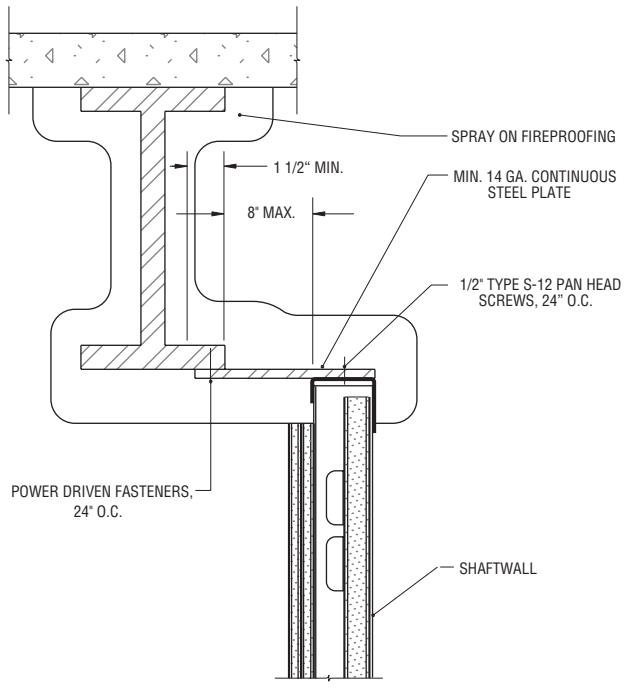

**SHAFTWALL OFFSET
FROM STEEL BEAM**

09260R
Scale: 1 1/2" = 1'-0"

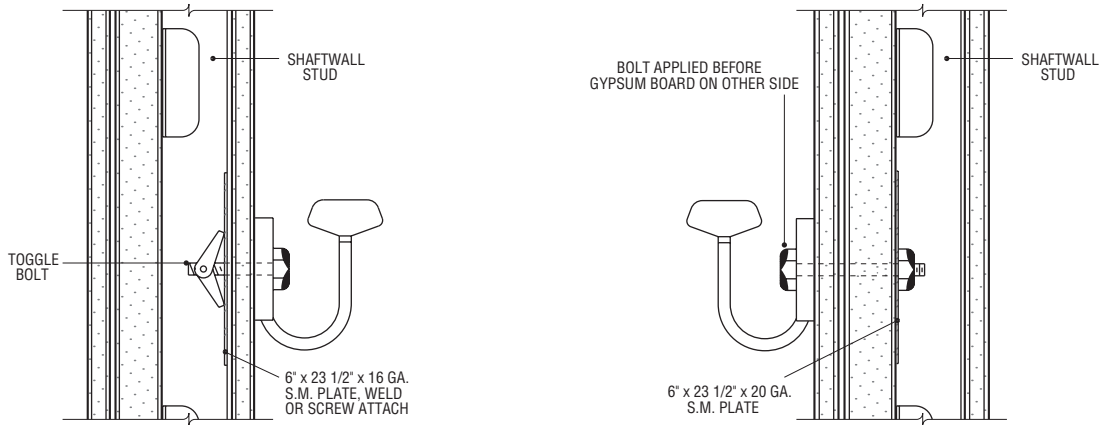

HANDRAIL SUPPORT DETAILS

NOTE: HANDRAIL BRACKET SHALL HAVE A MINIMUM AREA OF 3.25 SQ. IN. AND MINIMUM WIDTH ALONG BOTTOM EDGE OF 1 3/8" IF RECTANGULAR, AND A MINIMUM DIAMETER OF 2 3/8" IF ROUND IN ORDER TO COMPLY WITH 200 POUND PULLOUT AND/OR COMPRESSION TESTS (NFPA 101-1985 LIFE SAFETY CODE - BRACKETS).

09260U
Scale: 3" = 1'-0"

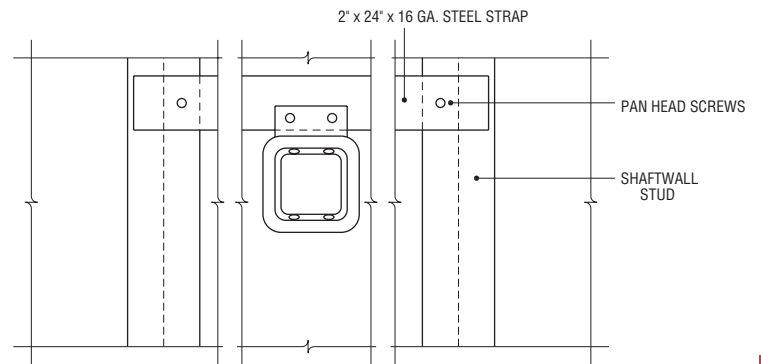
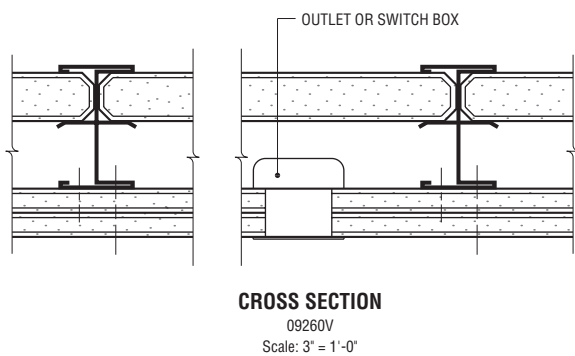

ELECTRICAL OUTLET SUPPORT

09260W
Scale: 3" = 1'-0"

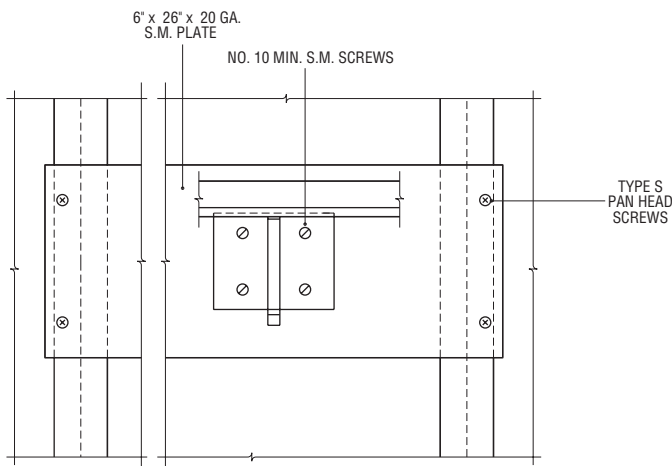

HANDRAIL SUPPORT DETAILS

09260S
Scale: 2" = 1'-0"

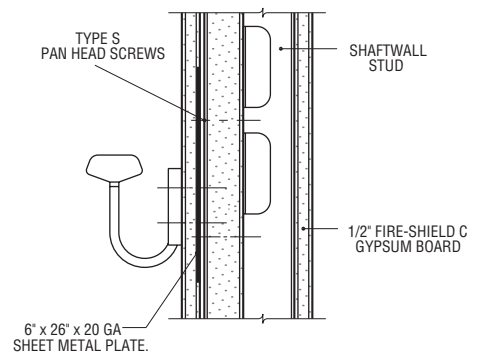

HANDRAIL SUPPORT DETAILS

09260T
Scale: 2 1/4" = 1'-0"

09 21 16.23

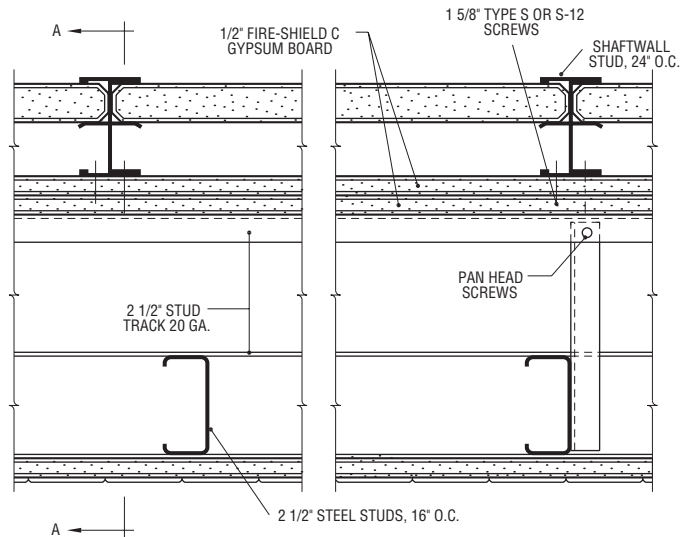

CHASE WALL
09260EE
Scale: 3" = 1'-0"

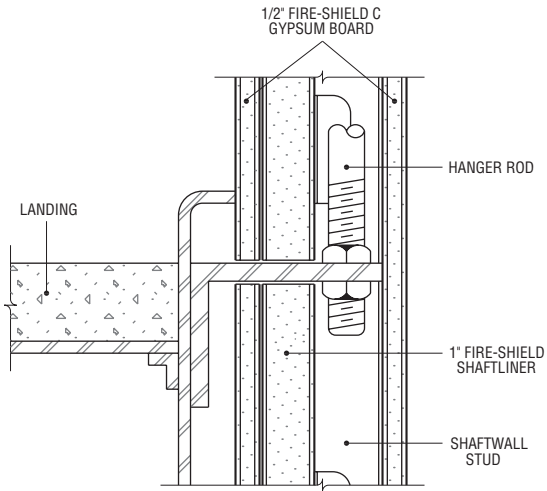

STAIR HANGER ROD
09260X
Scale: 3" = 1'-0"

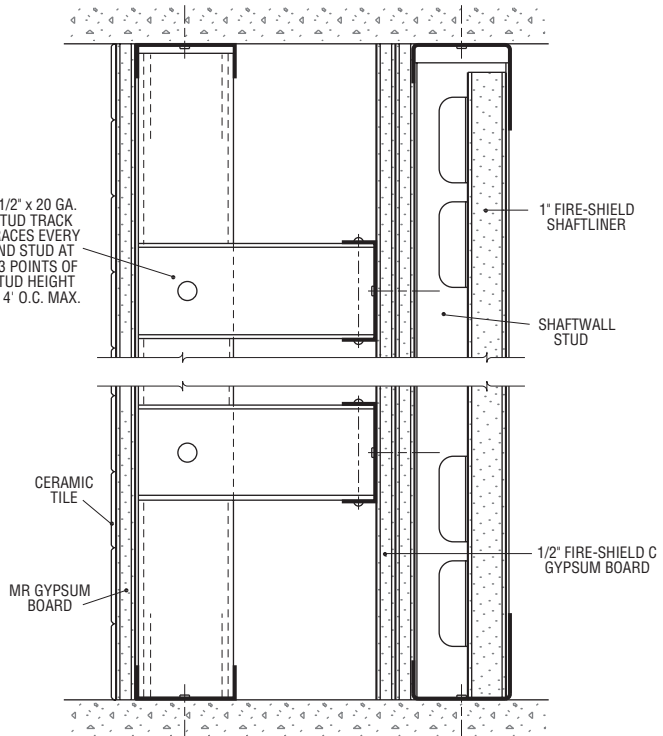

**SHAFTWALL CHASE WALL
(SECTION A-A)**
09260FF
Scale: 3" = 1'-0"

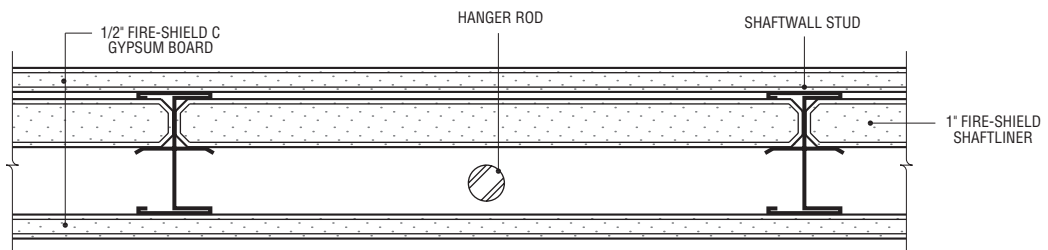

STAIRWELL STAIR HANGER ROD
09260Y
Scale: 3" = 1'-0"

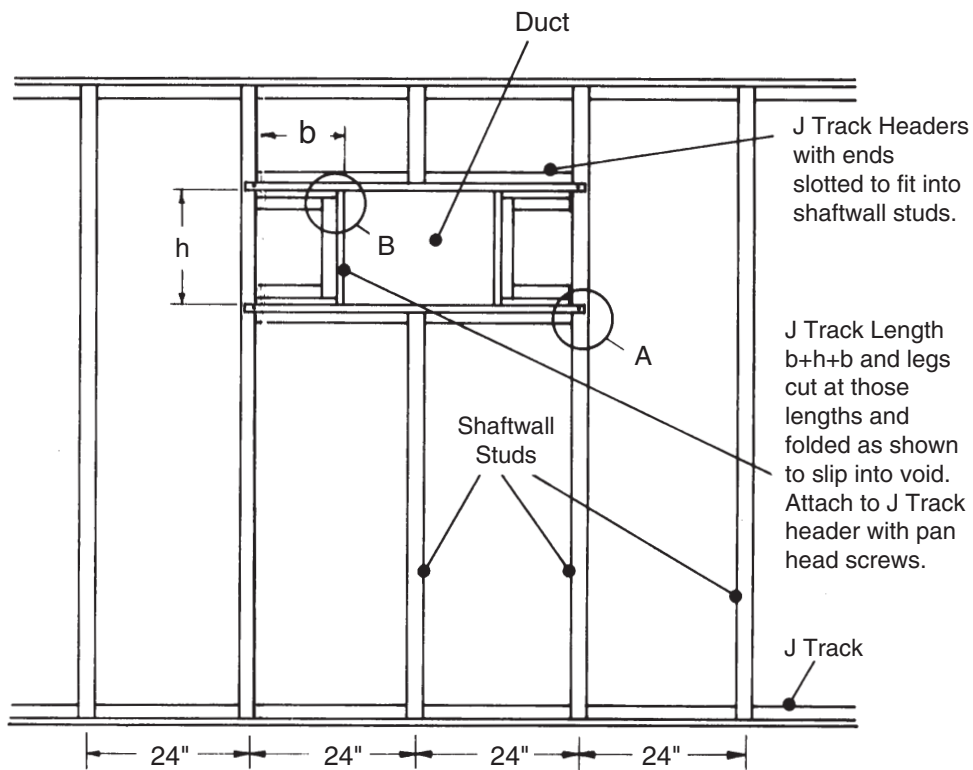

**TYPICAL DUCT OPENING
RECOMMENDED FRAMING**

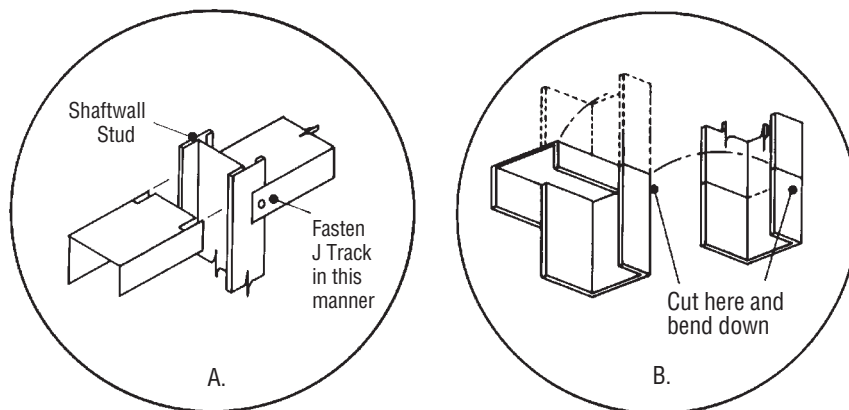

09 21 16.23

RECOMMENDATIONS

Shaftliner panels should be handled with care to prevent fracturing or deformation of edges.

FRAMING AND SHAFTLINER CAVITY SHAFTWALL

1. Locate and lay out partition floor and ceiling lines to ensure plumb partition.
2. Insure accurate stud spacing to maintain gypsum board face layer module.
3. Position top and bottom J Track with long leg toward the shaft along ceiling, floor and vertically at column and/or wall where erection of shaftwall will begin. Attach with power driven fasteners 24" o.c. max.
4. Frame all openings cut into partitions for ducts, etc. with J Track as shown in accompanying details to protect cut gypsum core edges and to provide resistance to bending and other stresses.
5. Cut shaftliner panels 1" less than ceiling height and install first by placing outside vertical edge against long leg of vertical track, plumb and attach with Type S 1 5/8" Screws 24" o.c.
6. Place studs within flanges of floor and ceiling track and rotate into place. Slide stud tabs/flange snugly over edge of shaftliner previously installed.
7. Install next shaftliner panel between tabs/flange of studs. Continue in this manner until end of partition run. Occasionally check spacing of studs to maintain 24" module.
8. At end of run, cut vertical J Track at least 2" short of partition height. Cut shaftliner 1/4" less than remaining width of partition and 2" short of full height. Lay piece of shaftliner 2" wide x length of opening in floor track as support for last shaftliner panel. Fit cut edge of shaftliner into vertical track and, holding shaftliner and track together, slide paper

bound edge of shaftliner into stud. Align last panel and fasten the vertical track with appropriate fasteners 24" o.c. max. Fasten shaftliner to vertical track with 1 5/8" Type S or S-12 Screws 24" o.c. See drawing on page 126 for alternate detail.

9. Locate shaftwall horizontal end joints within the upper and lower third points of wall. Stagger joints in adjacent panels to avoid continuous horizontal joint. Shaftliner horizontal end joints do not require taping, back blocking or framing. When using I-Studs the shaftliner panels shall be of sufficient length to engage a minimum of two I-Stub tabs along the edge.

GYPSUM BOARD

Apply first layer of 1/2" Fire-Shield C (5/8" Fire-Shield) Gypsum Board horizontally to face of studs with screws spaced 24" o.c. Apply second layer vertically with screws spaced 12" o.c. (Use 1" Type S Screws on first layer, 1 5/8" Type S Screws on second layer for 25 gauge nominal framing.) (Use 1" Type S-12 Screws on first layer, 1 5/8" Type S-12 Screws on second layer for 20 gauge or heavier framing.) Stagger all vertical and horizontal joints. For proper joint treatment, maintain uniform room temperature between 50°F and 70°F during cold weather. Treat joints of face layer with tape and joint compound.

CAULKING

Caulk Cavity Shaftwall system with acoustical sealant wherever the wall is enclosing shafts where positive or negative air pressure exists. Caulk perimeter of wall and at any other place where voids create the possibility of moving air causing dust accumulation, noise or smoke leakage. Caulking shall be done in compliance with details specified by the architect/designer.

AIR SHAFTS

The System is not designed to serve as an unlined air supply duct. Caulking is recommended at perimeters and penetrations wherever the I-Stub System is used to enclose elevators or other shafts where positive or negative pressures will exist. The contractor installing this System shall caulk in compliance with details specified by the architect/designer. Proper caulking will seal perimeters and penetrations to minimize air noises and dust associated with air movement.

FRAMING FOR OPENINGS

Frame doors and duct openings with J Track. Use adequate structural support for openings over 48" wide. For openings up to 48" wide, use vertical J Track on either side of openings. For head and sill of openings, place J Track horizontally across openings. Cut J Track about 12" longer than openings. Then cut flanges and fold back to nest over vertical J Track and fasten webs or flanges with two 3/8" Type S or 1/2" Type S-12 Pan Head Screws per connection. When nesting J Track to J Track, cut off short flange of horizontal J Track so it will fit over vertical J Track.

CALL BOXES AND POSITION INDICATORS

Protect call boxes, position indicators and fireman's switches as shown in drawings on page 130.

CHASES

When possible, locate all vertical rise, conduit, stair hangers, etc., within wall cavity. If the cavity in the 2 1/2" stud wall is not of sufficient width, the 4" or 6" studs can be used for chases or erect chase walls as shown on page 134.

ELEVATOR DOORS

Elevator door frames must be braced and supported independently of the

shaftwall. However, shaftwall must be tied into elevator door frames by being attached to jamb and anchor clips with pan head screws. The 3" leg, nominal 20 gauge J Track shall be used at the juncture of the elevator door frame and the Cavity Shaftwall System. See drawings on pages 128 and 129 for details.

Door frames (other than elevator door frames) should be formed from not less than 18 gauge steel, shop primed, with throat openings accurately formed to the nominal wall thickness plus 3/32". Frames must have trim returns not less than 7/16" in width to bear flush against the gypsum board surface. Floor anchor plates should be 14 gauge (min.) steel, firmly welded to frames and designed with not less than two anchor holes 3" o.c. minimum to prevent frame rotation. Anchor plates should be securely fastened to the floor with power driven fasteners having minimum dimensions of 3/16" diameter and 3/4" length. The type and size of fastener is dependent on job conditions, type of concrete or steel framing, etc., and must be sufficient to provide rigid, continuous anchorage to the frames. Jamb anchor clips should be formed from 18 gauge (min.) steel, and welded to jambs to provide adequate anchorage to jamb framing as shown on details. Elevator door frames must be fastened to and supported by the building structure, separately framed and independent of the partition. They shall be securely anchored to the sills and to the building structure or to the track supports. Anchors or fastenings to suit the wall construction are required and shall be not more than 2" apart. See details on pages 128 and 129 for connection of partition and elevator door frames.

DESCRIPTION

I-Stud Cavity Shaftwall
Systems can be erected horizontally and used as economical fire resistive assemblies for corridor ceilings, stair soffits, and protection for mechanical ducts.

The I-Stud Cavity Shaftwall System for Horizontal Duct Protection consists of I-Studs 24" o.c. with 1" Fire-Shield Shaftliner panels inserted in the stud tabs, and three layers of 1/2" Fire-Shield C Gypsum Board attached to the stud flanges opposite the Shaftliner panels. This System provides fire protection for mechanical ducts and has been tested from both sides.

Two layers of 1/2" Fire-Shield C Gypsum Board attached to the stud flanges opposite the Shaftliner panels provide 2-hour fire protection when used as a corridor ceiling or stair soffit.*

Similarly, single layer 5/8" Fire-Shield or Fire-Shield C Gypsum Board attached to the stud flanges opposite the Shaftliner panels provide 1-hour fire protection when used as a corridor ceiling or stair soffit.*

LIMITATIONS

I-Stud Cavity Shaftwall Systems erected horizontally for corridor ceilings or stair soffits are designed to carry their own deadweight only, and should not be used where there is access to an attic or loft above, or any probability of storage.

In addition, the 2-hour horizontal duct protection system is not designed to carry live loads or the weight of the mechanical ducting it is protecting.

Maximum allowable horizontal spans of each system are shown in the table below.

DETAILS

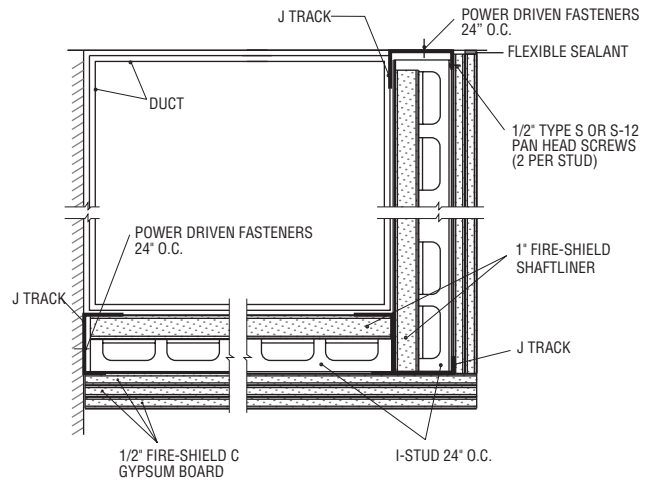

TWO HOUR HORIZONTAL DUCT PROTECTION
WHI 694-0300.1
09260GG
Scale: 2" = 1'-0"

TECHNICAL DATA

MAXIMUM HORIZONTAL SPANS FOR I-STUD ASSEMBLIES

Stud Size in. (mm)	Minimum Steel Thickness in. (mm)	Corridor Ceilings And Stair Soffits		Horizontal Membrane And Duct Protection
		1-Hour Fire Resistive Rating	2-Hour Fire Resistive Rating	2-Hour Fire Resistive Rating
2 1/2" (63.5 mm)	0.020 (.508)	7'-8" (2337 mm)	7'-8" (2337 mm)	7'-2" (2184 mm)
2 1/2" (63.5 mm)	0.0329 (.836)	8'-8" (2642 mm)	9'-4" (2845 mm)	8'-8" (2642 mm)
4" (102 mm)	0.020 (.508)	10'-3" (3124 mm)	10'-9" (3277 mm)	10'-0" (3048 mm)
4" (102 mm)	0.0329 (.836)	11'-9" (3581 mm)	12'-1" (3683 mm)	11'-3" (3429 mm)
6" (152 mm)	0.0329 (.836)	14'-10" (4521 mm)	14'-10" (4521 mm)	13'-10" (4216 mm)

Note: Spans based on L/240 deflection and twice the dead load weight, and 24" o.c. stud spacing.

DETAILS

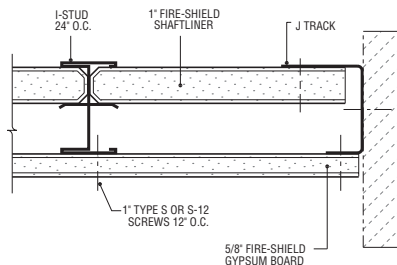

**ONE HOUR HORIZONTAL SHAFTWALL-
CORRIDOR CEILING AND STAIR SOFFIT***
09260II
Scale: 3" = 1'-0"

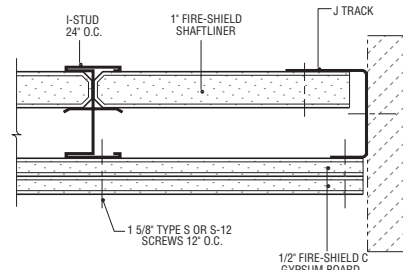

**TWO HOUR
CORRIDOR CEILING AND STAIR SOFFIT***
09260HH
Scale: 3" = 1'-0"

*See ICBO Evaluation Services, Inc. Evaluation Report No. 3579 for allowable values and/or conditions of use concerning material presented in this document. It's subject to re-examinations, revisions, and possible cancellations.

SECTION 09 21 16.23

SHAFTWALL SYSTEMS

THE FOLLOWING PARAGRAPHS ARE FOR INSERTION INTO SECTIONS OF GENERIC SPECIFICATIONS OR GENERIC/PROPRIETARY SPECIFICATIONS COVERING SHAFTWALL PRODUCTS. THE NATIONAL GYPSUM COMPANY PRODUCT NAME FOLLOWS THE GENERIC DESCRIPTION IN PARENTHESES.

PART 1 GENERAL

1.02 REFERENCES

- A. American Society for Testing and Materials (ASTM):
 1. C 840, Specification for Application and Finishing of Gypsum Board.
 2. C 1396, Specification for Gypsum Board.

PART 2 PRODUCTS

2.02 MATERIALS

- A. Gypsum Board:
 1. Fire-Resistant Gypsum Shaftliner Board: A gypsum core shaftwall panel with additives to enhance fire resistance of the core and surfaced with water repellent paper on front, back, and long edges and complying with ASTM C 1396, Type X (Gold Bond BRAND Fire-Shield Shaftliner).
 - a. Thickness: 1"
 - b. Width: 2'
 - c. Length: 7' through 14'
 - d. Edges: Beveled
 2. Fire-Resistant Mold-Resistant Gypsum Shaftliner Board: A gypsum core shaftwall board with additives to enhance fire resistance of the core and surfaced with a moisture/mold/mildew resistant paper on front, back, and long edges; and complying with ASTM C1396, Type X (Gold Bond BRAND Fire-Shield Shaftliner XP).
 - a. Thickness: 1"
 - b. Width: 2'
 - c. Length: 7' through 14'
 - d. Edges: Beveled
 - e. Mold and Mildew Resistance: Panel score of 10, when tested in accordance with ASTM D 3273
 3. Fire-Resistant Gypsum Board: A gypsum core wall panel with additives to enhance fire resistance of the core and surface with paper on front, back, and long edges and complying with ASTM C 1396, Type X.
 - a. Thickness: 1/2" (Gold Bond BRAND Fire-Shield C Gypsum Board), 5/8" (Gold Bond BRAND Fire-Shield Gypsum Board), or 5/8" (Gold Bond BRAND Fire-Shield C Gypsum Board).
 - b. Width: 4'
 - c. Length: 6' through 16' (1/2" Fire-Shield C Gypsum Board, 5/8" Fire-Shield Gypsum Board) Length: 8' through 14' (5/8" Fire-Shield C Gypsum Board)
 - d. Edges: Square, Tapered, or Beveled Taper (Sta-Smooth edge)

4. Fire-Resistant Mold-Resistant Gypsum Board:

A gypsum core wall panel with additives to enhance fire resistance and the water resistance of the core; surfaced with a moisture/mold/mildew resistant paper on front, back and long edges and complying with ASTM C 1396, type X.

 - a. Thickness: 1/2" (Gold Bond BRAND XP Fire-Shield C Gypsum Board) 5/8" (Gold Bond BRAND XP Fire-Shield Gypsum Board).
 - b. Width: 4'
 - c. Length: 8', 10' or 12'
 - d. Edges: Square or Tapered
 - e. Mold and Mildew Resistance: Panel score of 10, when tested in accordance with ASTM D 3273
 5. Fire-Resistant Plaster Base: A gypsum core panel with additives to enhance the fire resistance of the core and surfaced with absorptive paper on front, back, and long edges and complying with ASTM C 1396; Type X.
 - a. Thickness: 1/2" (Kal-Kore BRAND Fire-Shield C Plaster Base); 5/8" (Kal-Kore BRAND Fire-Shield Plaster Base).
 - b. Width: 4'
 - c. Length: 8' and 12'
 - d. Edges: Tapered
- B. Joint Treatment
1. Tape: 2 1/16" wide paper reinforcing tape (ProForm BRAND Joint Tape).
 2. Compound: Drying type pre-mixed compound (ProForm BRAND Multi-Use Joint Compound, ProForm BRAND All-Purpose Joint Compound, regular grade and machine grade, ProForm BRAND Lite Joint Compound, ProForm BRAND Ultra Joint Compound, and ProForm BRAND XP Joint Compound).
 3. Compound: Drying type job mixed vinyl base compound (ProForm BRAND Triple-T Compound).
 4. Compound: Drying type topping compound, pre-mixed (ProForm BRAND Topping Joint Compound, ProForm BRAND Ultra Joint Compound).
 5. Compound: Setting type job mixed chemical-hardening compound (ProForm BRAND Sta-Smooth Joint Compound, ProForm BRAND Sta-Smooth Lite Joint Compound).

PART 3 EXECUTION

3.01 INSTALLATION

- A. Install studs, tracks, shaftliner, gypsum board, accessories, and finish gypsum board joints in accordance with the following ASTM Standards and manufacturer's recommendations:
 1. ASTM Standards:
 - a. Metal Framing: C 754
 - b. Joint Treatment: C 840.
 2. Manufacturer's Recommendations: National Gypsum Company "Gypsum Construction Guide."

H-Stud Area Separation Wall System



09 21 16.33

National 
Gypsum®

H-STUD AREA SEPARATION WALL SYSTEM



The fire-protection of gypsum-based Area Separation Walls is demonstrated in dramatic fashion by the results of this actual townhouse fire in which the two-hour fire-rated assembly performed as expected in protecting adjacent properties. Break-away feature allowed collapse of fire-side structural framing without pulling down the entire wall.

DESCRIPTION

SOLID TYPE AREA SEPARATION WALL

The H-Stud Area Separation Wall consists of 2" light-gauge steel H-Studs which secure two layers of 1" Fire-Shield Shaftliner or 1" Fire-Shield Shaftliner XP board between adjacent studs.

Shaftliner board is faced with green moisture-resistant paper and Shaftliner XP board is faced with purple moisture/mold/mildew-resistant paper on both sides for protection against weather during installation. Shaftliner panels have a beveled edge configuration allowing for simple installation into the H-Studs.

The H-Studs are secured at the foundation floor by the flanges of H-Stud Track. The same track is used back-to-back at intermediate floors to provide a splicing means so that the System can be erected one floor at a time. H-Stud Track is also used at the roof line or at the parapet and at wall ends.

For a fire-rated assembly without the need for battens, a minimum 3/4" air space shall be maintained between the H-Stud assembly and

any adjacent framing members. When a 3/4" air space cannot be maintained, the H-Stud and H-Stud Tracks are covered by screw-attached 6" wide battens fabricated from 1/2" Fire-Shield C Gypsum Board; or 1/2" Fire-Shield C Gypsum Board boards can be fastened to the H-Studs and joints* covered with tape and joint compound to provide a finished wall. Mineral wool or glass fiber can be installed in adjacent cavity shaftwalls to provide higher STC ratings.

Steel H-Stud framing members are attached on each side to adjacent framing with breakaway, heat softenable aluminum ASW Clips.

*Refer to UL Design U347.
NOTE: ICC ES Inc. Legacy Report 90-26.01 requires a 1" minimum air space.

TECHNICAL DATA

1. Area Separation Walls are nonload-bearing walls. They should not be used where exposed to constant dampness and/or water.

Steel framing and XP Gypsum Board products permit temporary exposure to inclement weather during construction, but the constructed Area Separation Wall should be protected from inclement weather as soon as possible. Materials supplied to the job site should be stored properly, supported off the ground and protected from inclement weather.

2. The Area Separation Wall System may be built up to a maximum of 66' high.
3. Insulation in the Area Separation Wall must be protected from wetting and therefore shall not be installed until building is closed-in.
4. XP Gypsum Board or Gypsum Sheathing shall be used on faces of stud framing of Area Separation Walls which project beyond roof or side walls.

TYPICAL FLOOR/CEILING JUNCTURE

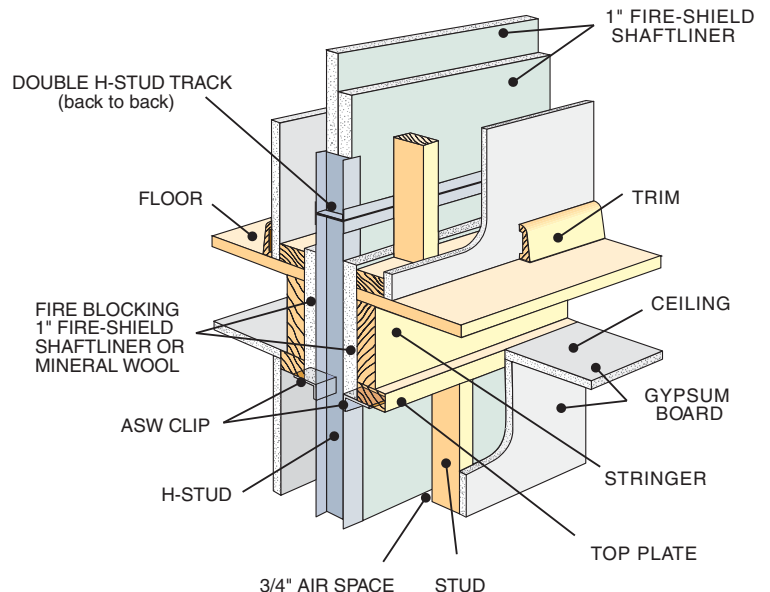

AREA SEPARATION WALL LIMITING HEIGHTS

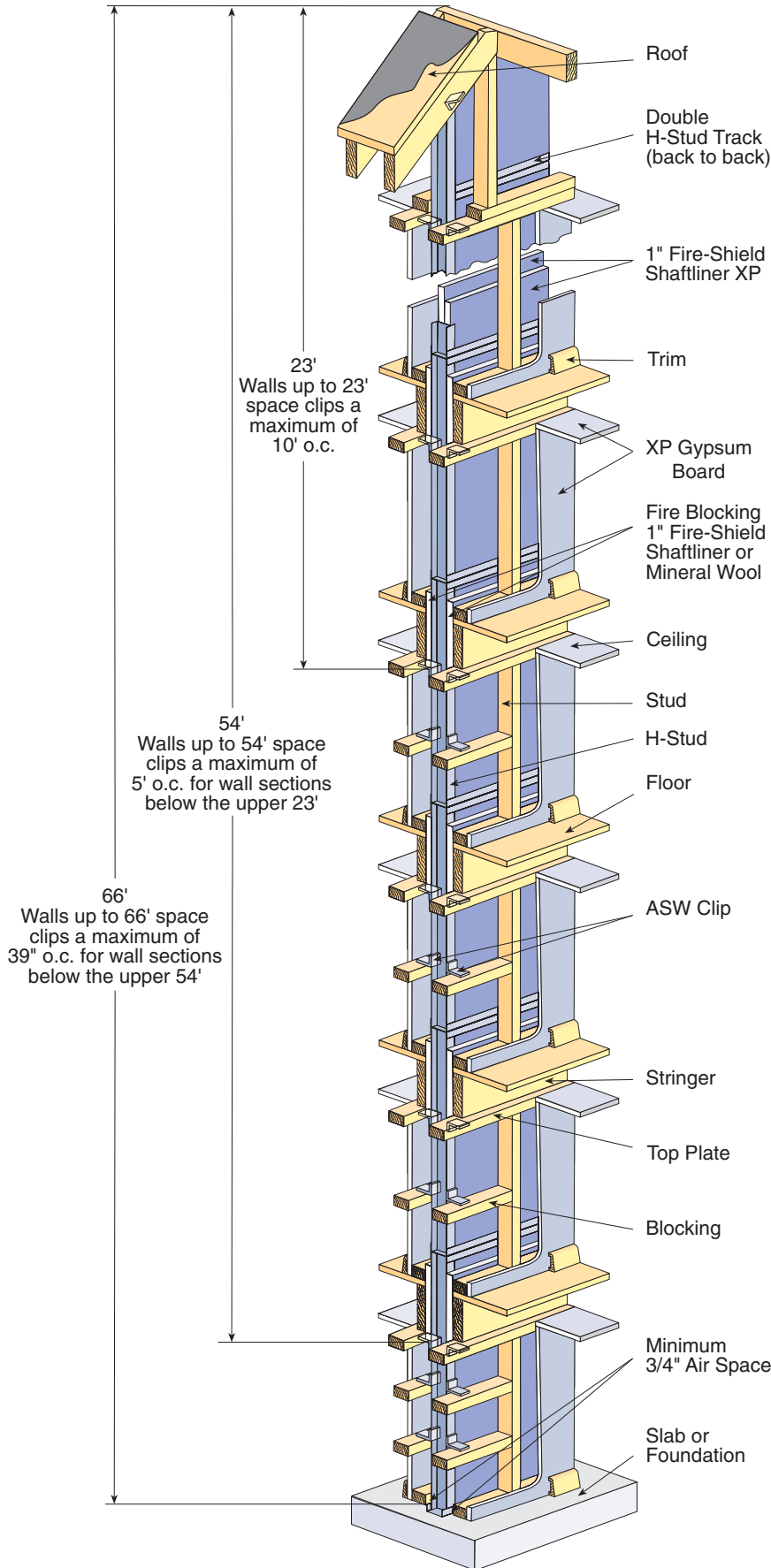

AREA SEPARATION WALL CLIP

The framing attachment ASW Clips are made from 0.050" aluminum alloy that softens at about 1000°F. They are formed in the shape of an angle and are available 2" wide with legs either 1" x 2", 1" x 2.5" or 2" x 2.5". Clips are attached to vertical steel H-Stud framing using one 3/8" Type S pan head screw and to adjacent framing with one 1 1/4" Type W screw.

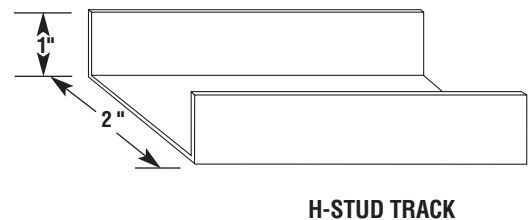
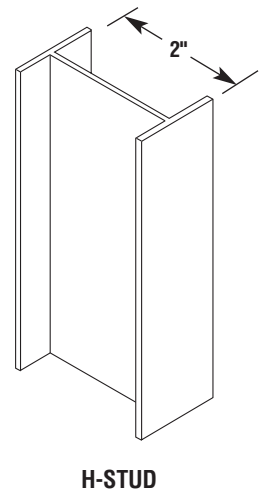
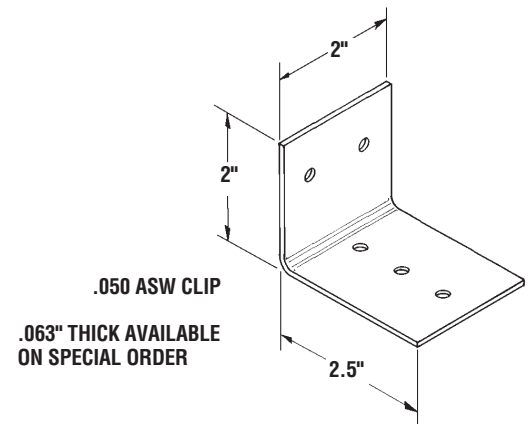

DETAILS

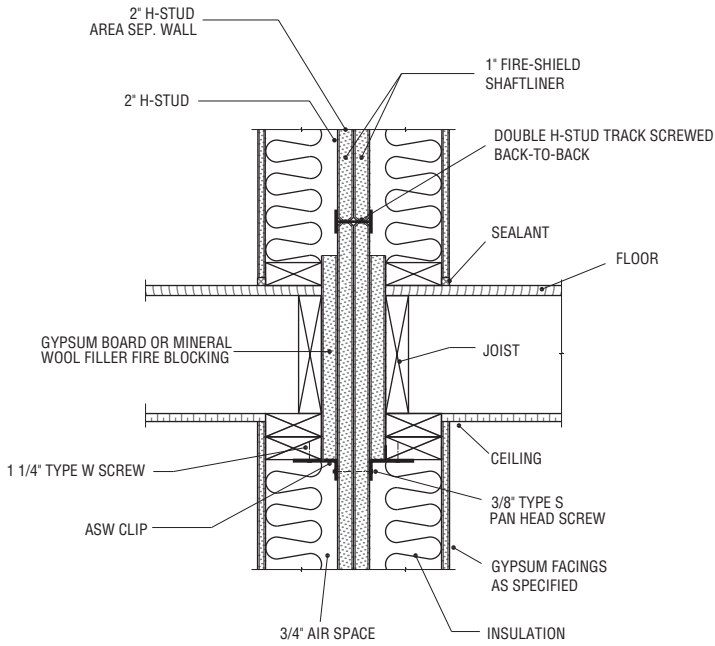

**INTERMEDIATE FLOOR INTERSECTION*
LOCATION OF ASW CLIPS**

09265I
Scale: 1" = 1'-0"

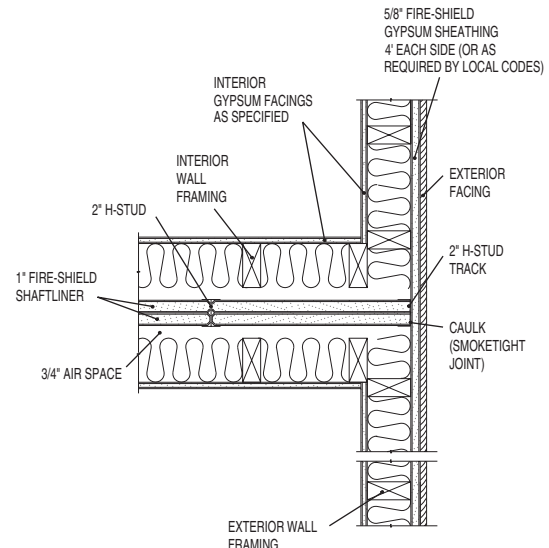

EXTERIOR WALL INTERSECTION

09265M
Scale: 1" = 1'-0"

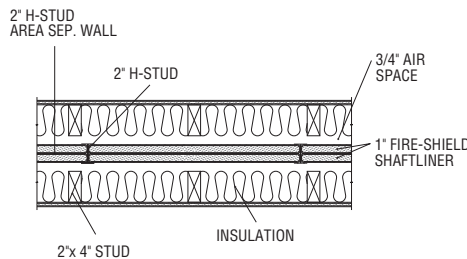

TYPICAL WALL CROSS SECTION*

09265G
Scale: 1/2" = 1'-0"

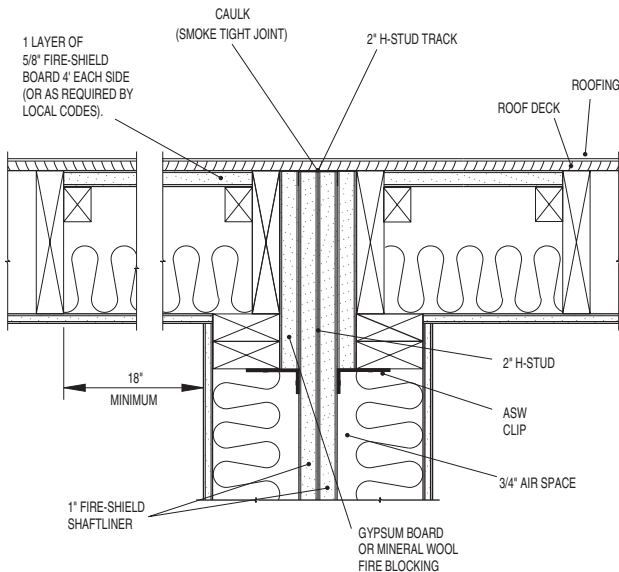

TYPICAL ROOF JUNCTION DETAIL

09265K
Scale: 1" = 1'-0"

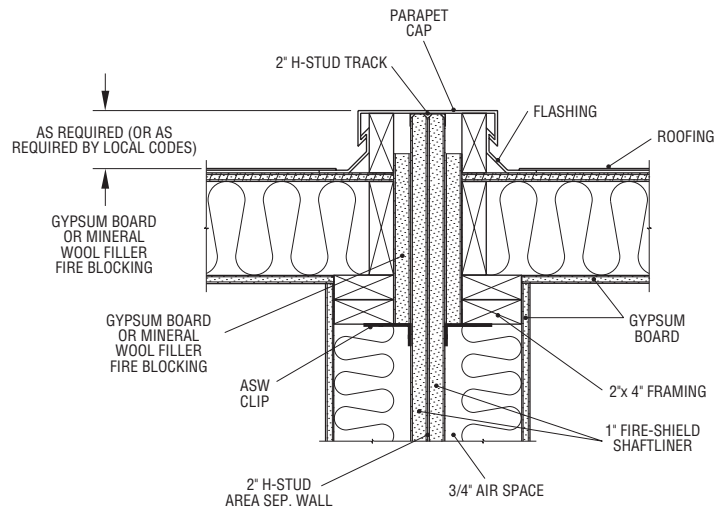

TYPICAL ROOF PARAPET DETAIL

09265J
Scale: 1" = 1'-0"

*When a 3/4" air space cannot be maintained between the H-Stud assembly and adjacent framing members, 1/2" Fire-Shield C Gypsum battens are required to cover H-Studs and H-Stud Track.

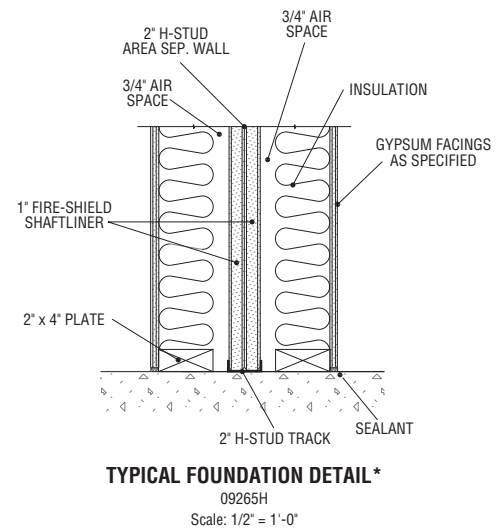
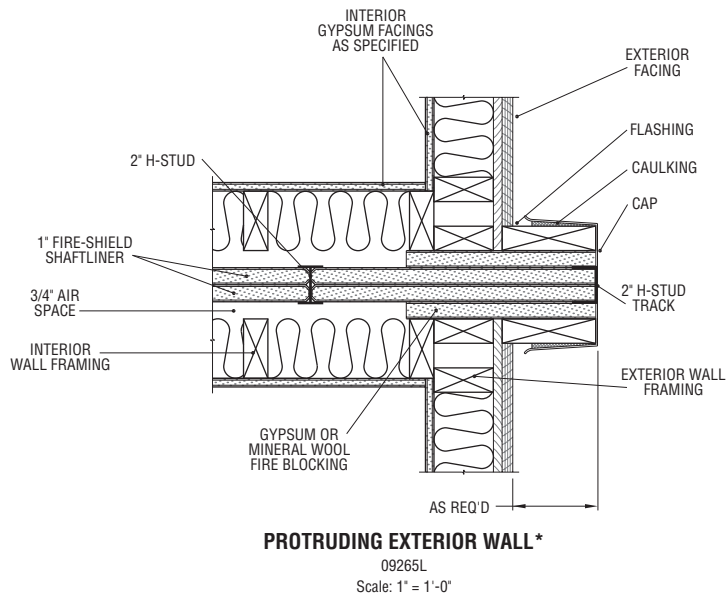

*When a 3/4" air space cannot be maintained between the H-Stud assembly and adjacent framing members, 1/2" Fire-Shield C Gypsum battens are required to cover H-Studs and H-Stud Track.

RECOMMENDATION

Order H-Studs and 1" Fire-Shield Shaftliner according to the following outline:

Basement wall section – length equal to distance from foundation floor to approximately 3" above floor line of first floor.

Intermediate floors – length equal to distance between floor lines.

Topmost floor – length to extend to top of parapet wall or to roof intersection, depending on detail.

BASEMENT WALL INSTALLATION

1. Beginning at foundation floor, attach 2" H-Stud Track to concrete with power-driven fasteners spaced 24" o.c. Apply acoustical sealant along edges of track at floor line.
2. Install H-Stud Track on foundation walls where Area Separation Wall intersects, if applicable. Fasten with power-driven fasteners 24" o.c. Caulk edges as with floor track.
3. At intersection of foundation or exterior wall and Area Separation Wall begin erecting by inserting first layer of 1" Shaftliner into floor and wall track. Insert second layer back-to-back with first and seat into floor and wall track. Shaftliner and studs may

4. be set into position from the basement floor or fed down through the space provided in the wood framing from the floor above.
5. Making sure that both pieces of Shaftliner are seated all the way into the floor and wall tracks and that their edges are flush, insert an H-Stud into the floor track and engage the H-Stud legs over the long edges of the Shaftliner boards. Seat the H-Stud fully so the board edges contact the stud web.
6. Continue in this manner, erecting two thicknesses of Shaftliner, and installing the legs of the H-Stud over the Shaftliner edges until wall is completed. Again, make sure all studs and boards are tightly pushed together. Floor track may be screw fastened to H-Studs with 3/8" Type S pan head screws to assist with installation.
7. If the Area Separation Wall terminates at a foundation wall, the last two Shaftliner boards will have to be inserted from the floor above. Boards are pushed down into the channel formed by the previous H-Stud's legs and the legs of the wall track.
8. If the Area Separation Wall terminates at or past a framed wall, insert the last boards conventionally and cap the end of the Area Separation Wall with

2" H-Stud Track. Fasten H-Stud track flanges at all corners on both sides with 3/8" Type S pan head screws.

8. The top edge of the erected wall is then capped off by placing 2" H-Stud Track over studs and boards. Track may be screw fastened to H-Studs with 3/8" Type S pan head screws to assist with installation.
9. Attach studs to adjacent wood framing with ASW Clips. Secure the clips to the studs with one 3/8" Type S Pan Head Screw through the short leg of the clip. The ASW Clips may be attached directly to the steel studs or through the gypsum board batten face into the studs.
10. A minimum 3/4" air space shall be maintained between the H-Stud assembly and any adjacent framing members.* When a 3/4" air space cannot be maintained, gypsum board batten strips are installed over H-Studs and H-Stud Track on both sides of the wall. 3" wide battens are installed over H-Stud Track at foundation and roof. 6" battens are screw-attached to H-Studs with 1" Type S screws spaced 12" o.c. screwed into alternate legs of H-Stud. Battens are cut from sheets of 1/2" Fire-Shield C Gypsum Board.

INTERMEDIATE FLOORS AND ROOF INSTALLATION

1. Attach 2" H-Stud Track to the already installed capping track of the lower floor's wall. This back-to-back track installation allows the Area Separation Wall to be erected one floor at a time. Secure the two tracks together with two 3/8" Type S pan head Screws 24" o.c. Stagger back-to-back track joints a minimum of 12".
2. Erect Shaftliner and H-Studs in the same manner as for the basement wall, steps 4-10, except that starting and ending procedures vary depending on the exterior wall intersection detail. See drawing details.
3. At roof intersection the walls are capped-off with H-Stud track. Track may be fastened to H-Stud with 3/8" Type S pan head screws to assist with installation. H-Studs are fastened to wood framing with ASW Clips. The specific framing procedure varies according to roof junction drawing details.
4. Fire blocking must be provided at intermediate floors and roof locations as shown in drawing details. Mineral wool or gypsum board filler may be used.

*Refer to UL Design U347.
NOTE: ICC Es, Inc. Legacy Report 90-26.01 requires a 1" minimum air space.

INTERIOR FACINGS

1. 2" H-Stud Area Separation Wall can be finished in a variety of ways depending on wall installation. For load-bearing applications, wood stud walls meeting required codes must be erected flanking the Area Separation Wall. Stud walls are then finished in whatever method is specified. For nonload-bearing applications, finished wall may be of any type meeting local codes including exposed Shaftliner and battens where appearance is not critical.

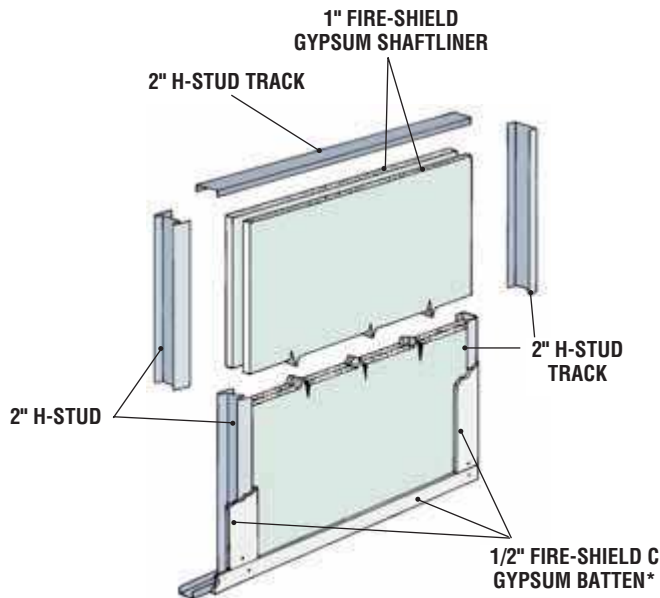

BASIC COMPONENTS OF 2" H-STUD AREA SEPARATION WALL (ASW CLIPS NOT SHOWN)

- * Battens not required when minimum 3/4" air space is maintained between H-stud wall and adjacent wood framing.

SPECIFICATIONS

SECTION 09 21 16.33

AREA SEPARATION WALL

THE FOLLOWING PARAGRAPHS ARE FOR INSERTION INTO SECTIONS OF GENERIC SPECIFICATIONS OR GENERIC/PROPRIETARY SPECIFICATIONS COVERING GYPSUM BOARD PRODUCTS FOR AREA SEPARATION WALLS. THE NATIONAL GYPSUM COMPANY PRODUCT NAME FOLLOWS THE GENERIC DESCRIPTION IN PARENTHESES.

PART 1 GENERAL

1.02 REFERENCES

- American Society for Testing and Materials (ASTM):
 1. C 1396, Specification for Gypsum Board.

PART 2 PRODUCTS

2.02 MATERIALS

- Gypsum Board:
 1. Fire-Resistant Gypsum Shaftliner Board: A gypsum core shaftwall board with additives to enhance fire resistance of the core and surfaced with water repellent paper on front, back, and long edges and complying with ASTM C 1396, Type X (Gold Bond BRAND Fire-Shield Shaftliner).
 - Thickness: 1"
 - Width: 2'
 - Length: 7' through 14'
 - Edges: Beveled

2. Fire-Resistant Mold-Resistant Gypsum Shaftliner Board: A gypsum core shaftwall board with additives to enhance fire resistance of the core and surfaced with a moisture/mold/mildew resistant paper on front, back, and long edges; and complying with ASTM C 1396, Type X (Gold Bond BRAND Fire-Shield Shaftliner XP).
 - Thickness: 1"
 - Width: 2'
 - Length: 7' through 14'
 - Edges: Beveled
 - Mold and Mildew Resistance: Panel score of 10, when tested in accordance with ASTM D 3273
3. Fire-Resistant Gypsum Board: A gypsum core wall board with additives to enhance fire resistance of the core and surfaced with paper on front, back, and long edges and complying with ASTM C 1396, Type X (Gold Bond BRAND Fire-Shield C Gypsum Board).
 - Thickness: 1/2"
 - Width: 4'
 - Length: 6' through 16'
 - Edges: Square, Tapered, or Beveled Taper (Sta-Smooth Edge)
4. Fire-Resistant Mold-Resistant Gypsum Board: A gypsum core wall panel with additives to enhance fire resistance and the water resistance of the core; surfaced with a moisture/mold/mildew resistant paper on front, back, and long edges and complying with ASTM C 1396, type X (Gold Bond BRAND XP Fire-Shield C Gypsum Board).
 - Thickness: 1/2"
 - Width: 4'
 - Length: 8' 10' or 12'
 - Edges: Square or Tapered
 - Mold and Mildew Resistance: Panel score of 10, when tested in accordance with ASTM D 3273

PART 3 EXECUTION

3.01 INSTALLATION

- General: In accordance with the manufacturer's recommendations, National Gypsum Company "Gypsum Construction Guide."

PermaBase[®] BRAND Cement Board Construction Guide



Perma
BASE[®]
BRAND
Cement Board

National 
Gypsum[®]

PERMABASE® BRAND CEMENT BOARD

DESCRIPTION

PermaBase® BRAND Cement Board is a rigid substrate made of Portland cement, aggregate and glass mesh that provides an exceptionally hard, durable surface that is able to withstand prolonged exposure to moisture.

PermaBase offers a competitive advantage over similar products on the market with its patented EdgeTech® technology. The tapered, double-wrapped edge design allows for closer nail or screw application to the edge.

FEATURES/BENEFITS

- Double-wrapped edge with EdgeTech technology allows for closer fastener application of nails or screws at the edge without crumbling or spinout.
- IRC and IBC 2006 Compliant – Meets ASTM C 1325.
- PermaBase resists the growth of mold and mildew achieving a panel score of 10, the highest score possible, per ASTM D 3273.*
- Homogeneous core has fewer voids and provides a very easy and clean score and snap.
- Can be cut utilizing a standard utility knife and straightedge. With PermaBase's unique core composition, little or no additional labor is needed to clean the edge after a cut.
- PermaBase is impact resistant, extremely durable and dimensionally stable. It has excellent overall flexural, compressive and tensile strength characteristics.
- PermaBase is highly moisture resistant, and will not rot, disintegrate or swell when exposed to water.
- 1/2" PermaBase may be used in 1 hour and 2 hour rated assemblies and is UL Classified.

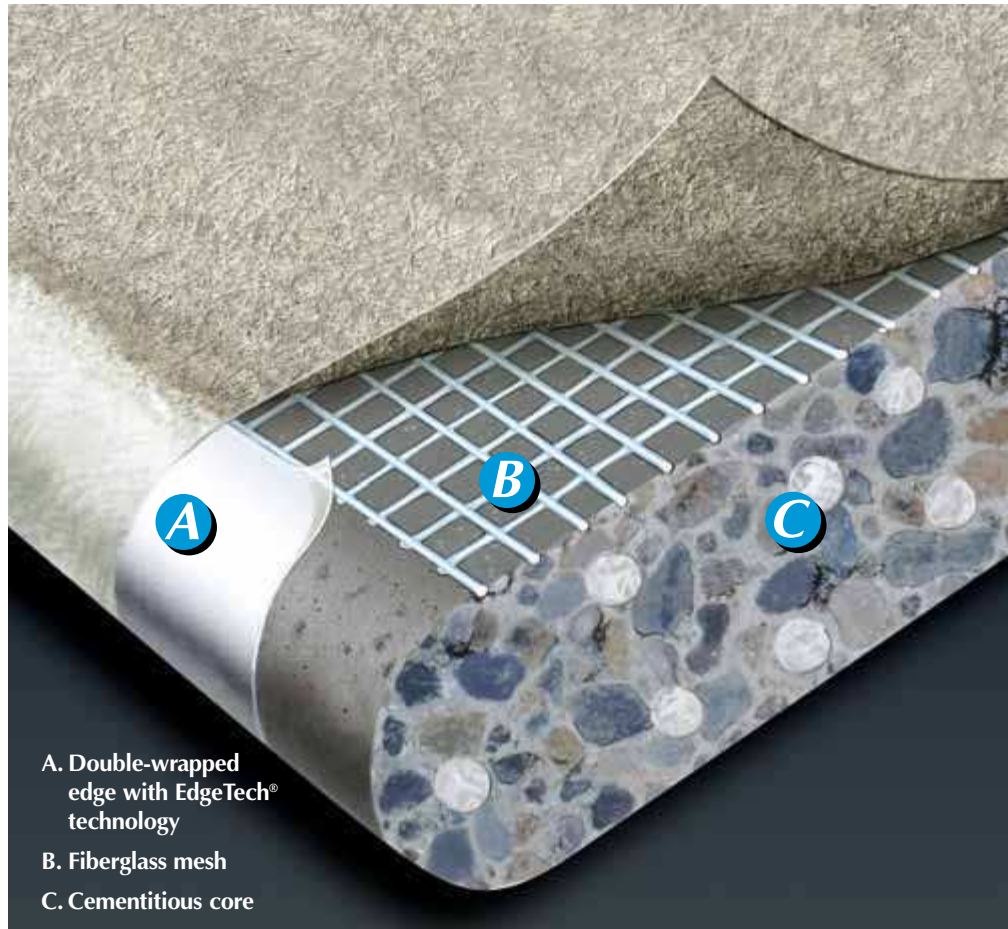

A. Double-wrapped edge with EdgeTech® technology
B. Fiberglass mesh
C. Cementitious core

- PermaBase has a smoother finish than other brands and has no open edges, which reduces hand chafing.
- 1/4" PermaBase is ideal for remodeling applications because it can be applied directly over a variety of existing countertop surfaces.
- As a floor underlayment 1/4" PermaBase eliminates the need to modify adjacent thresholds when abutting to carpeting, wood flooring and other common flooring materials.
- Lowest water absorption of any cement board per ASTM C 473.
- Can be used in residential and commercial saunas and steam rooms.



- Available in various widths, lengths and thicknesses.
- Can be used in 24" o.c. floor truss construction, with specific requirements.
- Suitable for both interior and exterior applications.

GridMarX®

1/4" PermaBase Underlayment has GridMarX, a pre-printed fastening pattern that ensures the proper number of fasteners while taking the guesswork out of spacing, layout and trimming.

*When tested by an independent laboratory per ASTM D 3273 ("Standard Test Method for Resistance to Growth of Mold on the Surface of Interior Coatings in an Environmental Chamber"), PermaBase achieved a panel score of 10, the highest score possible, indicating no mold growth under the laboratory test conditions. The use of PermaBase in actual installations may not produce the same results as were achieved in controlled laboratory conditions. No material can be considered "mold proof," nor is it certain that any material will resist mold indefinitely.

WARRANTY

- 30-year limited warranty for interior applications.
- 10-year limited warranty for exterior applications.

LIMITATIONS

- Joints should be treated with alkali resistant fiberglass mesh tape set in a latex-Portland cement mortar.
- Conventional paper drywall tape, joint compound and drywall nails or screws should not be used.
- Maximum wall framing spacing should not exceed 16" o.c. and must be designed to limit deflection to L/360 under all live and dead loads.
- Steel wall framing must be 20 ga. (galvanized) or heavier – 16" o.c.
- 1/4" PermaBase should not be used on walls or ceilings.
- PermaBase Cement Board is not a water barrier. Consult local building code for moisture barrier requirements.
- Not recommended for use with vinyl flooring.
- For exterior and interior finishes applied direct to PermaBase, reinforcing mesh must be embedded in basecoat. Consult finish manufacturer for additional requirements.
- PermaBase Cement Board should not be exposed to temperatures over 220°F (105°C).

COMPOSITION

CEMENTITIOUS BACKER UNIT (CBU): PermaBase Cement Board is a nailable, screwable backerboard and underlayment panel which is composed of Portland cement, aggregates and reinforcements that has a significant ability to remain unaffected by prolonged exposure to moisture. PermaBase complies with ASTM C 1325 and ANSI A118.9.

ACCESSORIES

JOINT REINFORCEMENT: PermaBase mesh tape must be used on all edges and cuts made to size. Use 2" wide polymer-coated (alkali resistant) mesh tape for interior applications and 4" wide polymer-coated (alkali resistant) mesh tape for exterior applications.

BONDING MATERIALS: Treat joint and set facing material preferably with latex-Portland cement mortar or with dry-set (thin-set) mortar. All mortars should comply with ANSI A118.1 or A118.4 standards. Type 1 organic adhesive meeting ANSI A-136.1 may be utilized for interior use only.

FASTENERS: Galvanized roofing nails, 1-1/2" long with hot dipped galvanized coating, for use with wood framing. Nails should meet Federal Specification #FF-N105B/ type 2 style 20.

PermaBase corrosion resistant screws or equivalent, 1-1/4" or 1-5/8" long, for use with wood framing. Type S-12 screws or equivalent, 1-1/4" or 1-5/8" long, for use with 20 ga. or heavier steel framing.

SIZES & PACKAGING

Size: Thickness, Width & Length	# of Pcs. Per Unit
PermaBase Cement Board	
1/2" x 32" x 5' (12.7 mm x 813 mm x 1524 mm)	50
1/2" x 36" x 4' (12.7 mm x 914 mm x 1219 mm)	50
1/2" x 36" x 5' (12.7 mm x 914 mm x 1524 mm)	50
1/2" x 36" x 6' (12.7 mm x 914 mm x 1829 mm)	50
1/2" x 36" x 8' (12.7 mm x 914 mm x 2438 mm)	30
1/2" x 48" x 8' (12.7 mm x 1219 mm x 2438 mm)	30
5/8" x 36" x 5' (15.9 mm x 914 mm x 1524 mm)	35
5/8" x 48" x 8' (15.9 mm x 1219 mm x 2438 mm)	24
3/8" x 48" x 8' (9.5 mm x 1219 mm x 2438 mm)	40*
3/4" x 48" x 8' (19.0 mm x 1219 mm x 2438 mm)	20*
1" x 32" x 8' (25.4 mm x 813 mm x 2438 mm)	20*
PermaBase Underlayment	
1/4" x 48" x 4' (7.9 mm x 1219 mm x 1219 mm)	50
1/4" x 36" x 5' (7.9 mm x 914 mm x 1524 mm)	50

* Special order

COMPARISON CHART

Physical Feature Benefits	PermaBase	Other Cement Boards	Fiber Cement Boards
Lowest Weight Glass Mesh Cement Board	●	○	○
Double-Wrapped Edge	●	○	○
Fastens Near Edge With No Breakout	●	○	○
Highest Damage Resistancy From Handling	●	○	○
Cleanest To Score And Snap	●	○	○
Lowest Water Absorption	●	○	○
Meets 40 psf Rating Wind Load Test Results (Stud spacing 16" o.c.)	●	○	○
Cuts With Utility Knife vs. Power Tools	●	●	○
Standard Fasteners Countersink Into Board	●	●	○
Can Be Used In Both Residential and Commercial Steam Rooms And Saunas	●	●	○
Fewer Expansion Joints Needed	●	●	○
Inorganic vs. Organic Core	●	●	○
30-Year Warranty For Interior Use	●	●	○
10-Year Warranty For Exterior Use	●	●	○

Product Feature: ● Yes ○ No

TAPE & SCREWS

National Gypsum recommends the use of PermaBase Tape and PermaBase Screws to complete your installation.



INTERIOR APPLICATIONS

APPLICATIONS

An ideal underlayment for interior applications such as:

- Shower and tub enclosures
- Garden/whirlpool tubs
- Countertops
- Backsplashes
- Steamrooms and saunas
- Swimming pool and whirlpool decks and enclosures
- Floor underlayment
 - Entryways
 - Kitchens
 - Bathrooms
 - Foyers
 - Laundry rooms

INSTALLATION

GENERAL: All framing should comply with local building code requirements and be designed to provide support with a maximum allowable deflection of $L/360$ under all intended loads. Framing members should be spaced a maximum of 16" o.c.

Note: Cut or score PermaBase on printed side of panel. Install tile and tile setting materials in accordance with current ANSI specifications and Tile Council of America (TCA) guidelines.

CONTROL JOINTS: For interior installations, allow a maximum of 30 lineal feet between control joints. A control joint must be installed but not limited to the following locations: where expansion joints occur in the framing or building (discontinue all cross furring members located behind joint); when boards abut dissimilar materials; where framing material changes; at changes of building shape or structural system; at each story separation. Place control joints at corners of window and door openings, or follow specifications of architect. Control joint cavity shall not be filled with coating or other materials.

WALLS & CEILINGS

WALL FRAMING: Edges of PermaBase parallel to framing should be continuously supported. Provide additional blocking when necessary to permit proper PermaBase attachment.

TUB & SHOWER SURROUND

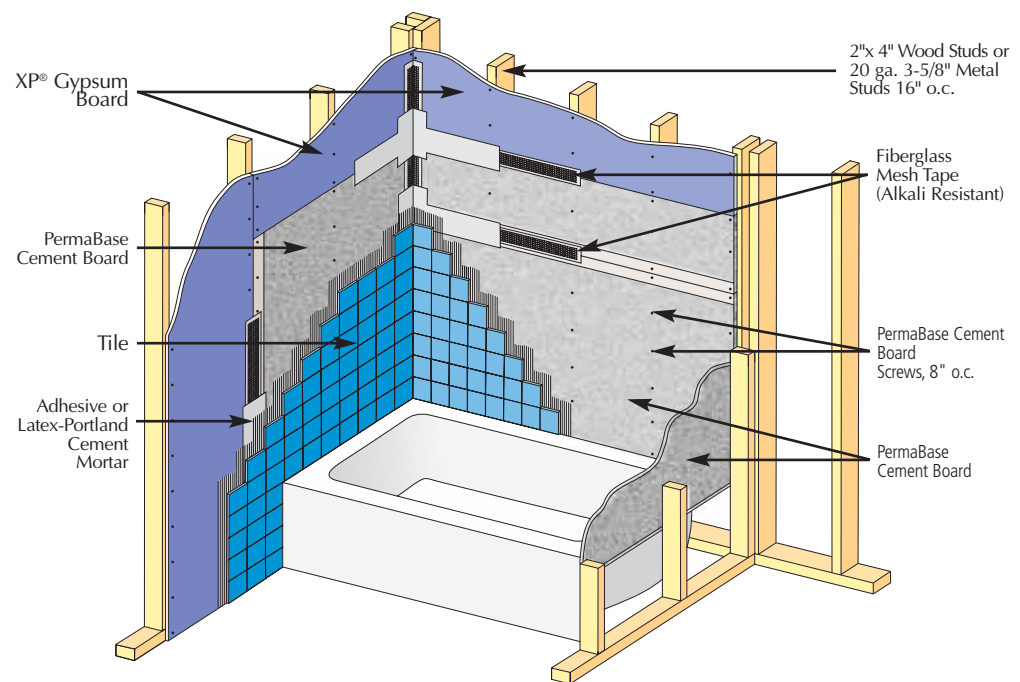

Do not install PermaBase directly over protrusions from stud plane such as heavy brackets and fastener heads. Studs above a shower floor should either be notched or furred to accommodate the thickness of the waterproof membrane or pan. The surround opening for a tub or pre-cast shower receptor should not be more than 1/4" longer than unit to be installed.

CEILING FRAMING: The deflection of the complete ceiling assembly due to dead load

(including insulation, PermaBase, bonding material and facing material) should not exceed $L/360$. The dead load applied to the ceiling frame should not exceed 10 psf. Ceiling joist or furring channel should not exceed 16" o.c. (Edges of PermaBase parallel to framing should be continuously supported.) Provide additional blocking when necessary to permit proper PermaBase attachment.

PERMABASE CEMENT BOARD:

Apply PermaBase with ends and edges closely butted but not forced together. Stagger ends joints in successive courses. Drive fasteners into field of cement board first, working toward ends and edges. Space fasteners maximum 8" o.c. for walls, 6" o.c. for ceilings with perimeter fasteners at least 3/8" and less than 5/8" from ends and edges. Ensure PermaBase is tight to framing.

FLOOR UNDERLAYMENT



COUNTERTOP

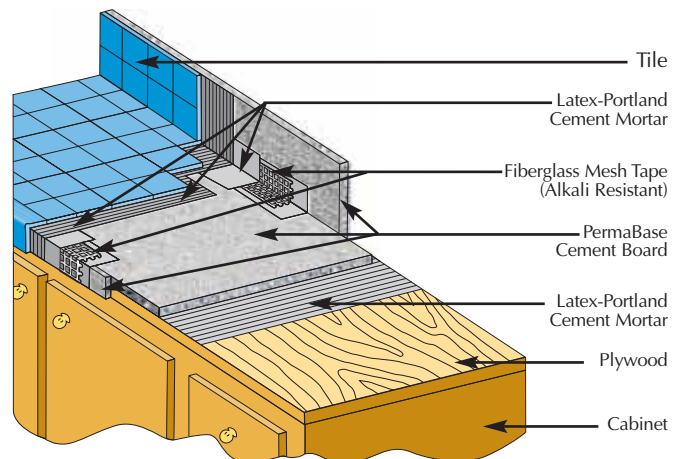
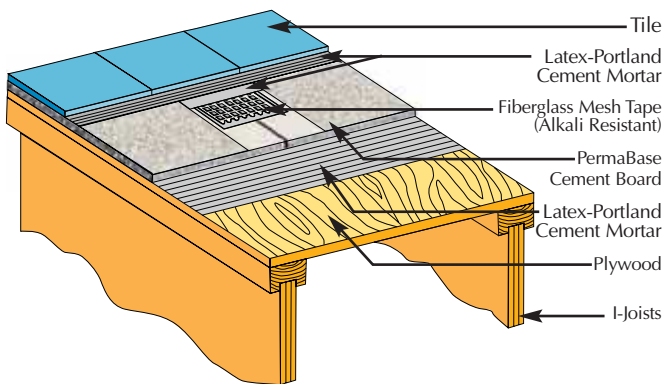

JOINT REINFORCEMENT:

Trowel bonding material to completely fill the tapered recessed board joints and gaps between each panel. On non-tapered joints apply a 6" wide, approx. 1/16" thick coat of bonding material over entire joint. For all joints, immediately embed 2" alkali resistant fiberglass mesh tape fully into applied bonding material and allow to cure. Same bonding material should be applied to corners, control joints, trims and other accessories. Feather bonding material over fasteners to fully conceal.

FLOORS & COUNTERS

SUBFLOOR OR BASE: For flooring applications with 16" o.c. floor joists, 5/8" tongue and groove exterior grade plywood or 3/4" tongue and groove exterior grade OSB may be used. For 19.2" o.c. and 24" o.c. floor joists, 3/4" tongue and groove exterior grade plywood or OSB must be used. Tile size for floors with 24" o.c. floor joists must be 12" x 12" or larger. The joist and subfloor assembly must meet L/360 as well as the appropriate code tables for live and dead loads.

UNDERLAYMENT: Using a 1/4" square-notched trowel, apply a setting bed of latex-Portland cement mortar (or thin-set mortar) to the subfloor or counter base. Immediately laminate PermaBase to subfloor or base leaving a 1/8" space between boards at all joints and corners. Leave a 1/4" gap along walls.

Stagger all joints so that they do not line up with underlying substrate joints. Fasten PermaBase every 8" o.c. throughout board field and around all edges while setting bed mortar is still workable.

Around perimeter of each board, locate fasteners 2" from corners and not less than 3/8" from the edges. Fill all joints solid with bonding material. On non-tapered joints such as butt ends, apply a 6" wide, 1/16" thick coat over the entire joint. For all joints, immediately embed 2" fiberglass mesh tape fully into applied bonding material; ensure that tape is centered over joint. Apply bonding material over fasteners to fully conceal. Remove all excess bonding material and allow to cure.

EXTERIOR APPLICATIONS

APPLICATIONS

An ideal substrate for exterior applications such as:

- Tile applications
- Stucco applications
- Countertops
- Soffit panels
- Sheathing panels
- Decks
- Outdoor kitchens/grills

INSTALLATION

GENERAL: All framing should comply with local building code requirements and be designed to provide support with a maximum allowable deflection of L/360 under all intended live (including wind) and dead loads.

Note: Cut or score PermaBase on rough side of panel. Install tile and tile setting materials in accordance with current ANSI specifications and Tile Council of America (TCA) guidelines.

CONTROL JOINTS: For exterior installations, allow a maximum of 16 lineal feet between control joints. (For exterior tile applications, control joints should be spaced a maximum of every 12'.) A control joint must be installed but not limited to the following locations: where expansion joints occur in the framing or building (discontinue all cross furring members located behind joint); when boards abut dissimilar materials; where framing material changes; at changes of building shape or structural system; at each story separation. Place control joints at corners of window and door openings, or follow specifications of architect. Control joint cavity shall not be filled with coating or other materials.

DECKS

SUBFLOOR: Plywood should be securely glued and fastened to floor joists spaced a maximum of 16" o.c. Subfloor should be sloped at a minimum pitch of 1/4" per foot. The floor surface should be true to plane within 1/8" in 10'.

UNDERLAYMENT: Using a 1/4" square-notched trowel, apply a setting bed of latex-Portland cement mortar to the subfloor. Immediately laminate PermaBase to subfloor, leaving a 1/8" space between boards at all joints and corners. Leave a 1/4" gap along walls. Stagger all joints so they do not line up with underlying substrate joints. Fasten PermaBase every 8" o.c. throughout board field and around all edges while setting bed mortar is still workable. Around the perimeter of each board, locate fasteners 2" from the corners and not less than 3/8" from the edges. Fill all joints solid with bonding material. On non-tapered joints such as butt ends, apply a 6" wide, 1/16" thick coat over the entire joint. For all joints, immediately embed alkali resistant fiberglass mesh tape fully into applied bonding material; ensure that tape is centered over joint. Apply bonding material over fasteners to fully conceal. Remove all excess bonding material and allow to cure.

WATERPROOF MEMBRANE: Trowel apply waterproof membrane to the entire surface of the PermaBase, following membrane manufacturer's installation instructions in detail.

WALLS & CEILINGS

WALL FRAMING: Studs should be spaced a maximum of 16" o.c. Edges/ends of PermaBase parallel to framing should be continuously supported. Provide additional blocking when necessary to permit proper PermaBase attachment. Do not install PermaBase directly over protrusions from stud plane such as heavy brackets or fastener heads.

CEILING FRAMING: The deflection of the complete ceiling assembly due to dead load (including insulation, PermaBase, bonding material and facing material) should not exceed L/360. The dead load applied to the ceiling frame should not exceed 10 psf. Ceiling joist or furring channel should not exceed 16" o.c. (Edges of PermaBase parallel to framing should be continuously supported.) Provide additional blocking when necessary to permit proper PermaBase attachment.



WEATHER BARRIER: While PermaBase is unaffected by moisture, a water barrier must be installed to protect the cavity. It should be installed according to the manufacturer's specifications.

PERMABASE CEMENT BOARD: Apply PermaBase with ends and edges closely butted but not forced together. Stagger end joints in successive courses. Drive fasteners into field of cement board first, working toward ends and edges. Space fasteners maximum 8" o.c. for walls, 6" o.c. for ceilings with perimeter fasteners at least 3/8" and less than 5/8" from ends and edges.

JOINT REINFORCEMENT: Trowel bonding material to completely fill the tapered recessed board joints and gaps between each panel. On non-tapered joints apply a 6" wide, approx. 1/16" thick coat of bonding material over entire joint. For all joints, immediately embed 4" alkali resistant fiberglass mesh tape fully into applied bonding material and allow to cure. Same bonding material should be applied to corners, control joints, trims or other accessories. Feather bonding material over fasteners to fully conceal.

WATER-MANAGED, HIGH-IMPACT RESISTANT WALL SYSTEM

CEMENT BOARD STUCCO WALL SYSTEM

APPLICATIONS

Cement Board Stucco is a water-managed exterior wall system designed to provide increased high-impact and weather resistance and improved dimensional stability where exterior insulation value is not required. For the purposes of meeting structural racking or fire code requirements, it is applied over the following approved sheathings: Exposure 1 or exterior plywood (grade C-D or better); Exposure 1 OSB; glass mat gypsum substrate meeting ASTM C 1177; or water resistant core gypsum (ASTM C 1396).

It combines the strength and durability of PermaBase Cement Board with the performance and beauty of reinforced base coats and textured finishes. All finishes are available in a limitless color selection and offer performance enhancement options ranging from extra mildew resistance to added flexibility.

Behind the system, a weather-resistant barrier complying with ASTM D-226 protects approved sheathings and other structural components and serves as a component to evacuate incidental water. Cement Board Stucco allows you to enclose and finish a project in as little as two days, speeding occupancy.

USES

For high-impact and weather-resistant exterior wall in residential and low-rise commercial applications.

ADVANTAGES

DURABILITY/STRENGTH:

Moisture resistant, durable PermaBase Cement Board substrates applied over a primary sheathing provide extraordinary impact and puncture resistance to the system.

WEATHER RESISTANCE:

100% Acrylic base coats and finishes repel weather at the system's surface.

WATER-MANAGED DESIGN:

The water-managed design of the system provides drainage to the exterior of incidental water that might enter around or through window or door openings and penetrate behind the cladding in frame construction.

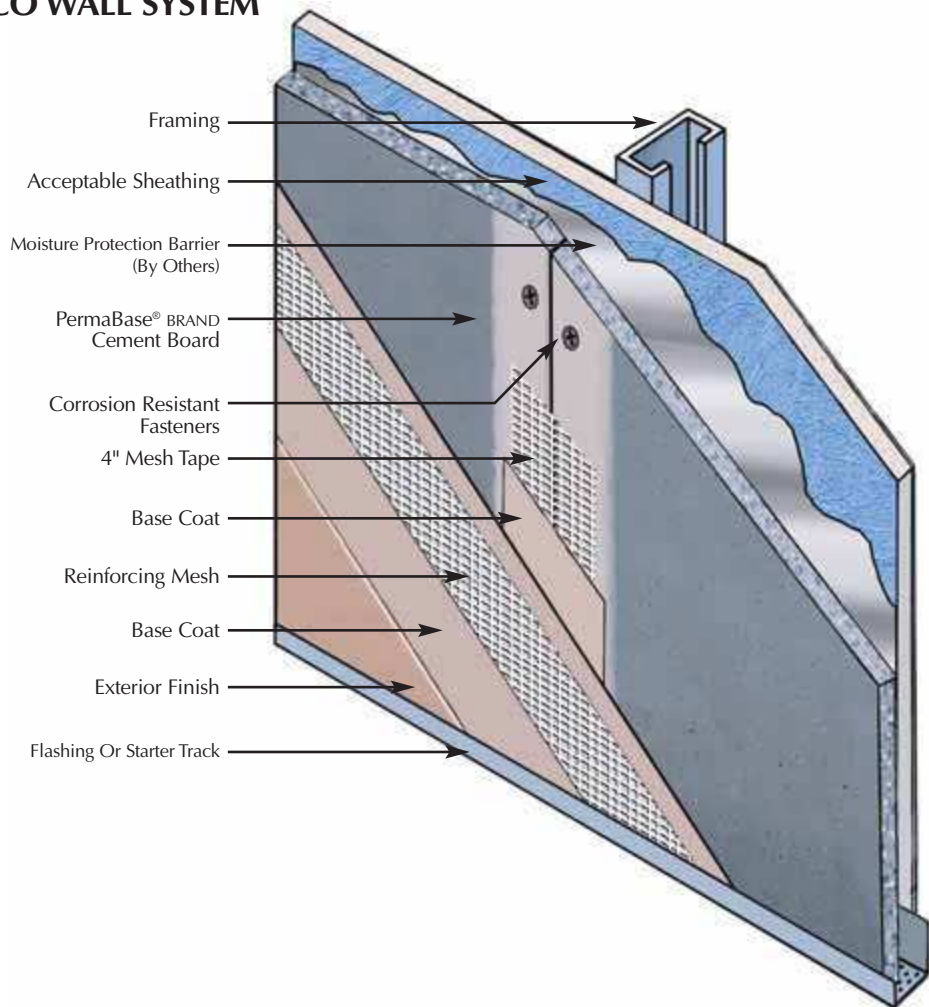

DESIGN OPTIONS:

Cement Board Stucco provides the popular stucco look, including the attachment of special pre-molded shapes and a wide variety of finish texture and color options in standard colors and custom colors.







Contact exterior coatings manufacturer for color and installation instructions.

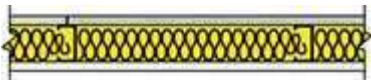
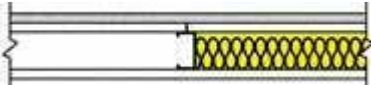

LIMITATIONS

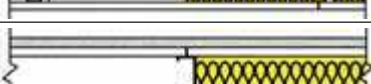
- Use is limited to residential and low-rise commercial applications.
- Thin veneer construction will tend to reveal planar irregularities in the frame construction.
- Minor cracking at joints might become visible in the finished exterior surface.

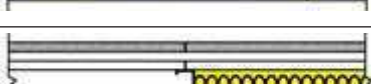
- For exterior finishes applied direct to PermaBase, reinforcing mesh must be embedded in basecoat. Consult exterior manufacturer for additional installation requirements.
- For conventional Portland Cement plaster systems, self-furring metal lath must be used over PermaBase and adhered to studs.

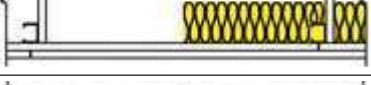
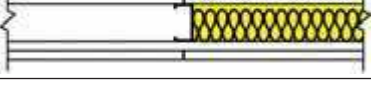
FIRE-RATED ASSEMBLIES

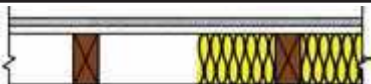
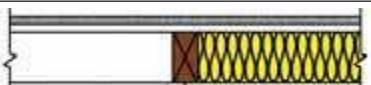
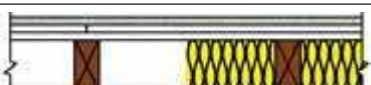
UL LISTED PERMABASE® CEMENT BOARD PARTITIONS – STEEL FRAMING		
Fire Rating	UL Design No.	Description
1 hr.	V452	 1/2" PermaBase applied vertically or horizontally to one side of 3-5/8" steel studs 16" o.c. 5/8" Fire-Shield Gypsum Board applied vertically to opposite side. 3" mineral wool insulation in stud cavities.
1 hr.	V438	 1/2" PermaBase applied vertically or horizontally over 5/8" Fire-Shield Gypsum Board applied vertically to each side of 3-5/8" steel studs 24" o.c. PermaBase secured to studs with cement board screws of adequate length to penetrate studs 3/8" spaced 8" o.c.
1 hr.	U420	 1/2" PermaBase applied vertically or horizontally over 5/8" Fire-Shield Gypsum Board applied vertically to each side double row of 1-5/8" steel studs 24" o.c. spaced 6" apart. PermaBase secured to studs with cement board screws of adequate length to penetrate studs 3/8" spaced 8" o.c.
1 hr. Load Bearing	U425	 1/2" PermaBase applied vertically or horizontally over 5/8" Fire-Shield Gypsum Board applied vertically to each side of 3-1/2", 20 gage steel studs 24" o.c. PermaBase secured to studs with cement board screws of adequate length to penetrate studs 3/8" spaced 8" o.c.
2 hr.	V452	 1/2" PermaBase applied vertically over 1/2" Fire-Shield C Gypsum Board, applied vertically to one side of 3-5/8" steel studs 16" o.c. 2 layers 1/2" Fire-Shield C Gypsum Board applied vertically to opposite side. 3" mineral wool insulation in stud cavities.
2 hr.	V438	 1/2" PermaBase applied vertically or horizontally over two layers 5/8" Fire-Shield Gypsum Board applied vertically to each side of 2-1/2" steel studs 24" o.c. PermaBase secured to studs with cement board screws of adequate length to penetrate studs 3/8" spaced 8" o.c.
2 hr.	U420	 1/2" PermaBase applied vertically or horizontally over two layers 5/8" Fire-Shield Gypsum Board applied vertically to each side double row of 1-5/8" steel studs 24" o.c. spaced 6" apart. PermaBase secured to studs with cement board screws of adequate length to penetrate studs 3/8" spaced 8" o.c.
2 hr. Load Bearing	U425	 1/2" PermaBase applied vertically or horizontally over two layers 5/8" Fire-Shield Gypsum Board applied vertically to each side of 3-1/2", 20 gage steel studs 24" o.c. PermaBase secured to studs with cement board screws of adequate length to penetrate studs 3/8" spaced 8" o.c.
3 hr.	V438	 1/2" PermaBase applied vertically or horizontally over three layers 5/8" Fire-Shield Gypsum Board applied vertically to each side of 2-1/2" steel studs 24" o.c. PermaBase secured to studs with cement board screws of adequate length to penetrate studs 3/8" spaced 8" o.c.

UL LISTED PERMABASE® CEMENT BOARD PARTITIONS – WOOD FRAMING		
Fire Rating	UL Design No.	Description
1 hr.	U305	 1/2" PermaBase applied vertically or horizontally over 5/8" Fire-Shield Gypsum Board applied horizontally or vertically to each side of 2x4 wood studs 16" o.c. PermaBase secured to studs with cement board screws of adequate length to penetrate studs 3/4" spaced 8" o.c.
1 hr.	U309	 1/2" PermaBase applied vertically or horizontally over 5/8" Fire-Shield Gypsum Board applied horizontally or vertically to each side of 2x4 wood studs 24" o.c. PermaBase secured to studs with cement board screws of adequate length to penetrate studs 3/4" spaced 8" o.c.
2 hr.	U301	 1/2" PermaBase applied vertically over two layers 5/8" Fire-Shield Gypsum Board, applied either horizontally or vertically to each side of 2x4 wood studs 16" o.c. PermaBase secured to studs with cement board screws of adequate length to penetrate studs 3/4" spaced 8" o.c.
2 hr.	U371	 1/2" PermaBase applied vertically over either two layers 5/8" Fire-Shield Gypsum Board, applied either horizontally or vertically to the interior side of 2x4 wood studs 16" o.c., or over 5/8" Gypsum Sheathing applied to exterior side with portland cement stucco, brick veneer, thin brick finishes. PermaBase secured to studs with cement board screws of adequate length to penetrate studs 3/4" spaced 8" o.c.

PERMABASE® BRAND CEMENT BOARD TECHNICAL DATA

TECHNICAL DATA

FIRE-RATED WALL ASSEMBLIES

PermaBase Cement Board has been tested and/or approved for use in a variety of fire-rated wall systems.

1-HOUR RATING – The 1-hour wall assembly consists of 3-5/8" steel studs, 16" o.c., one layer of 1/2" PermaBase attached horizontally or vertically with 1-1/4" long cement board screws 8" o.c. in the field and perimeter on one side and one layer of 5/8" Fire-Shield® wallboard attached vertically on opposite side with joints staggered to those of opposite side, with 1-1/4" long drywall screws 8" o.c. in the field and perimeter with 3" thick mineral fiber insulation batts in the stud cavities. UL V452, ITS/WHI Report No. J99-4001.

2-HOUR FIRE RATING – The 2-hour wall assembly consists of 3-5/8" steel studs, 16" o.c. on one side, base layer of 1/2" Fire-Shield C wallboard attached vertically with 1" dry-wall screws 24" o.c. in the field and perimeter and face layer of 1/2" PermaBase attached vertically with 1-5/8" cement board screws, 8" o.c. in the field and perimeter. Two layers of 1/2" Fire-Shield C wallboard applied vertically to the opposite side, base layer attached with 1" drywall screws 24" o.c. in the field and perimeter and face layer attached with 1-5/8" drywall screws 12" o.c. in the field and perimeter, with 3" thick mineral fiber insulation batts in the stud cavities. All joints staggered between face and base layer. UL V452, ITS/WHI Report No. J98-32931.

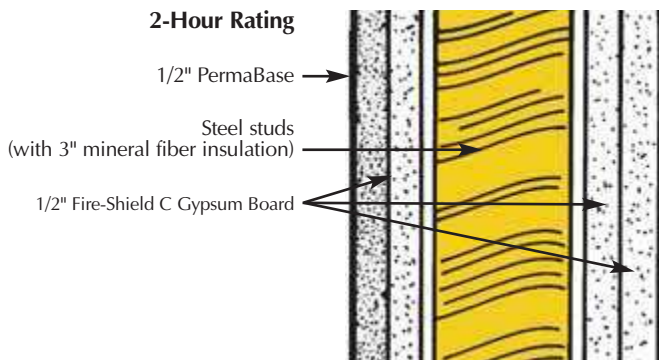
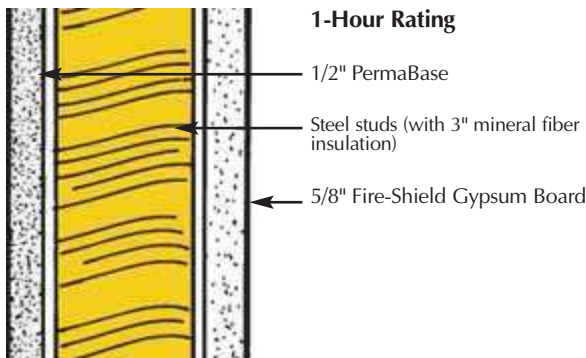

PHYSICAL PROPERTIES			
Property	Test Method	1/2" PermaBase	
Water Absorption % by Weight/24 Hours	ASTM C 473	<8	
Flexural Strength (psi)	ASTM C 947	750	
Fastener Holding (Wet and Dry, lbs.)	ASTM D 1037 (0.400" head diameter)	90	
Weight (psf)	ASTM C 473	3	
Freeze/Thaw (cycles) per ANSI A118.9	ASTM C 666 Procedure B	100	
Flame Spread/Smoke Developed	ASTM E 84	0/0	
Compressive Strength (psi) (Indentation)	ASTM D 2394	2250	
Wind Load (psf, studs 16" o.c.)	ASTM E 330	40	
Thermal "R"/k Value	Property of Material	0.2/2.7	
Bending Radius (ft.)	Property of Material	5	
Standard Method for evaluating ceramic floor installation system	ASTM C 627	Light Commercial	
Falling Ball Impact (12" drop)	ASTM D 1037	pass	
Shear Bond Strength 7 days (psi)	Dry-Set Portland Cement Mortar	ANSI A118.1	204
	Latex-Portland Cement Mortar	ANSI A118.4	241
	Organic Adhesives Type 1	ANSI A136.1	159
Linear Variation (Due to change in moisture content)	ASTM D 1037	0.05%	
Fungus Resistance	ASTM G 21	(No growth)	
Mold Growth on Surface	ASTM D 3273*	10	

* When tested by an independent laboratory per ASTM D 3273 ("Standard Test Method for Resistance to Growth of Mold on the Surface of Interior Coatings in an Environmental Chamber"), PermaBase achieved a panel score of 10, the highest score possible, indicating no mold growth under the laboratory test conditions. The use of PermaBase in actual installations may not produce the same results as were achieved in controlled laboratory conditions. No material can be considered "mold proof," nor is it certain that any material will resist mold indefinitely.

PermaBase meets the following codes and standards:

- 2006 International Residential Code
- 2006 International Building Code
- ASTM C 1325
- ANSI A118.9
- ICC Acceptance Criteria 59 (AC59)

Code Report References

- ICBO ES Inc. ER-5731
- PermaBase Cement Board
- National Evaluation Service Inc. Report No. NER-578
- PermaBase Cement Board

PermaBase Flex[®] BRAND Cement Board

DESCRIPTION

PermaBase Flex[®] BRAND Cement Board is a polymer-modified cement board reinforced with an alkali-resistant fiber mesh ideal for use around ceilings, beams, columns, arches and archways, walls and anywhere an evenly curved surface is required.

APPLICATIONS

- Radius wall construction
- Exterior and interior columns
- Barrel ceilings
- Radius shower walls
- Radius tub step-ups
- Radius archways
- Radius stair construction
- Saunas and steamrooms

FEATURES/BENEFITS

- 6" (150 mm) minimum radius for 90° corners.
- Bends immediately, easily and evenly.
- The only 1/2" lightweight cement board that bends.
- Can be bent without water saturation or kerf cuts.
- Easy installation, reduces skilled labor costs.
- Easy to cut and install with screws.
- Can be used for interior or exterior applications.
- Impact resistant.
- Creates uniform curved surfaces.
- Unaffected by water or moisture.
- Dimensionally stable.



LIMITATIONS

- For convex surfaces, PermaBase Flex must be applied with the rough surface and tapered edges exposed.
- For concave surfaces, PermaBase Flex must be applied with the smooth surface exposed.
- PermaBase Flex Cement Board should not be used for fire-rated assemblies.
- Maximum framing spacing should not exceed 8" o.c. and must be designed to limit deflection to less than L/360 under all live and dead loads.
- Steel framing must be 20 gauge or heavier.
- PermaBase Flex should be used on curved walls and ceilings. For flat walls and ceilings refer to PermaBase Cement Board.
- PermaBase Flex Cement Board is vapor permeable and unaffected by water but is not a water barrier. Consult local building code for moisture barrier requirements.
- On exterior installations a waterproof membrane must be applied behind PermaBase Flex Cement Board.

- Do not use drywall nails, screws or fiberglass mesh tape.
- Maximum fastener spacing should not exceed 8" o.c. for wall and 6" o.c. for ceiling applications.

PermaBase Flex makes curved designs easy to achieve. On this indoor pool ceiling application, PermaBase Flex is used with a hard coat plaster finish.

TECHNICAL DATA

PHYSICAL PROPERTIES		
Property	Test Method	PermaBase Flex
Compressive Strength (psi) (Indentation)	ASTM D 2394	1022
Weight (psf)	ASTM C 473	3.0
Water Absorption % by Weight/24 Hours	ASTM C 473	Less than 8
Falling Ball Impact (12" drop)	ASTM D 1037	Pass

Sizes/Packaging

Thickness: 1/2" (12.7 mm)
Width: 4' (1219 mm)
Length: 8' (2438 mm)
Mass: 3.0 lb./ft. (14.6 kg/m)
Packaging: 30 boards per package.

INSTALLATION

INTERIOR APPLICATIONS

WALL FRAMING: Studs should be spaced a maximum of 8" o.c. Edges/ends of PermaBase Flex parallel to framing should be continuously supported. Provide additional blocking when necessary to permit proper PermaBase Flex attachment. Do not install PermaBase Flex directly over protrusions from stud plane such as heavy brackets or fastener heads.

Studs above a shower floor should be either notched or furred to accommodate the thickness of the waterproof membrane or pan. The surround opening for a tub or pre-cast shower receptor should not be more than 1/4" longer than unit to be installed.

CEILING FRAMING: The deflection of the complete ceiling assembly due to dead load (including insulation, PermaBase Flex, bonding material and facing material) should not exceed L/360. The dead load applied to the ceiling frame should not exceed 10 psf. Ceiling joist or furring channel should not exceed 8" o.c. Edges of PermaBase Flex parallel to framing should be continuously supported. Provide additional blocking when necessary to permit proper PermaBase attachment.

PERMABASE FLEX CEMENT BOARD: Apply PermaBase Flex with ends and edges closely butted but not forced together. Stagger end joints in successive courses. Drive fasteners into field of cement board first, working toward ends and edges. Space fasteners maximum 8" o.c. for walls, 6" o.c. for ceilings with perimeter fasteners at least 3/8" and less than 5/8" from ends and edges. Ensure PermaBase Flex is tight to framing.

JOINT REINFORCEMENT: Trowel bonding material to completely fill the tapered recessed board joints and gaps between each panel. On non-tapered joints apply a 6" wide,

approx. 1/16" thick coat of bonding material over entire joint. For all joints, immediately embed 2" alkali-resistant fiberglass mesh tape fully into applied bonding material and allow to cure. Same bonding material should be applied to corners, control joints, trims or other accessories. Feather bonding material over fasteners to fully conceal.

EXTERIOR APPLICATIONS

WALL FRAMING: Studs should be spaced a maximum of 8" o.c. Edges/ends of PermaBase Flex parallel to framing should be continuously supported. Provide additional blocking when necessary to permit proper PermaBase Flex attachment. Do not install PermaBase Flex directly over protrusions from stud plane such as heavy brackets or fastener heads.

WEATHER BARRIER: While PermaBase Flex is unaffected by moisture, a water barrier must be installed to protect the cavity. It should be installed according to the manufacturer's specifications.

CEILING FRAMING: The deflection of the complete ceiling assembly due to dead load (including insulation, PermaBase Flex, bonding material and facing material) should not exceed L/360. The dead load applied to the ceiling frame should not exceed 10 psf. Ceiling joist or furring channel should not exceed 8" o.c. (Edges of PermaBase Flex parallel to framing should be continuously supported.) Provide additional blocking when necessary to permit proper PermaBase Flex attachment.

PERMABASE FLEX CEMENT BOARD: Apply PermaBase Flex with ends and edges closely butted but not forced together. Stagger end joints in successive courses. Drive fasteners into field of cement board first, working toward ends and edges. Space fasteners maximum 8" o.c. for walls, 6" o.c. for ceilings with perimeter fasteners at least 3/8" and less than 5/8" from ends and

Interior Installation

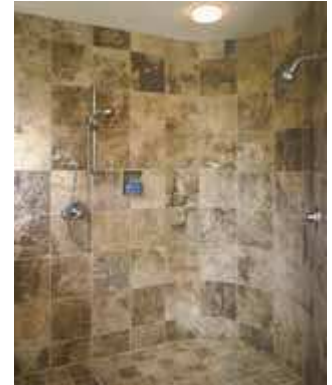

Exterior Installation



edges. Ensure PermaBase Flex is tight to framing.

JOINT REINFORCEMENT: Trowel bonding material to completely fill the tapered recessed board joints and gaps between each panel. On non-tapered joints apply a 6" wide, approx. 1/16" thick coat of bonding material over entire joint. For all joints, immediately embed 4" alkali-resistant fiberglass mesh tape fully into applied bonding material and allow to cure. Same bonding material should be applied to corners, control joints, trims or other accessories. Feather bonding material over fasteners to fully conceal.

CONTROL JOINTS: For interior installations, allow a maximum of 30 lineal feet between control joints. For exterior installations, allow a maximum of 16 lineal feet between control joints. (For exterior tile

applications, control joints should be used a maximum of every 12'.) A control joint must be installed but not limited to the following locations: where expansion joints occur in the framing or building (discontinue all cross furring members located behind joint); when boards abut dissimilar materials; where framing material changes; at changes at building shape or structural system; at each story separation. Place control joints at corners of window and door openings, or follow specifications of architect.

GENERAL: All framing should comply with local building code requirements and be designed to provide support with a maximum allowable deflection of L/360 under all intended live (including wind) and dead loads.

SPECIFICATIONS

SECTION 09 28 00 CEMENT BOARD

A. This section is written in CSI 3-part format and it assumes that the general conditions of the contract will be AIA A201. This section is proprietary and includes only National Gypsum products.

PART 1 GENERAL

1.01 SUMMARY

A. Section includes:

1. Cement backerboard for ceramic tile, other interior and exterior applications for walls and ceilings.
2. Underlayment for ceramic tile installations for interior and exterior floors.
3. Substrate for ceramic tile installation for interior and exterior countertops.

1.02 SUBMITTALS

A. Product Data: Manufacturers' specifications and installation instructions for each product specified.

1.03 DELIVERY, STORAGE, AND HANDLING

- A. Packaging and Shipping: Have materials shipped in manufacturer's original packages showing manufacturer's name and product brand name.
- B. Storage and Protection: Store materials inside and protected from damage by the elements. Protect ends, edges, and faces of cement boards from damage.

PART 2 PRODUCTS

2.01 MANUFACTURER

A. National Gypsum Company

2.02 MATERIALS

A. Cement Board

1. Backer Board: Cementitious, water-durable board; surfaced with fiberglass reinforcing mesh on front and back; long edges wrapped; and complying with ANSI A118.9 and ASTM C 1325 (PermaBase BRAND Cement Board).

- a. Thickness: 1/2" or 5/8"
- b. Width: 2' 8", 3', or 4'
- c. Length: 4', 5', 6', or 8'
- d. Edges: Tapered
- e. Density: 72 lbs. per cu. ft.
- f. Water Absorption: Not greater than 8% when tested for 24 hours in accordance with ASTM C 473.

2. Bendable Backer Board: Cementitious, water-durable board; surfaced with fiberglass reinforcing mesh on front and back; long edges wrapped; and complying with ANSI A118.9 (PermaBase Flex BRAND Cement Board).

- a. Thickness: 1/2"
- b. Width: 4'
- c. Length: 8'
- d. Edges: Tapered
- e. Density: 72 lbs. per cu. ft.
- f. Water Absorption: Not greater than 8% when tested for 24 hours in accordance with ASTM C 473.

3. Underlayment: Cementitious, water-durable board; surfaced with fiberglass reinforcing mesh on front and back; long edges wrapped; and complying with ANSI A118.9 and ASTM C 1325 (PermaBase BRAND Cement Board).

- a. Thickness: 1/4"
- b. Width: 3' or 4'
- c. Length: 5'
- d. Edges: Tapered
- e. Density: 72 lbs. per cu. ft.
- f. Water Absorption: Not greater than 8% when tested for 24 hours in accordance with ASTM C 473.

B. Fasteners:

1. Nails: 1-1/2" long, hot dipped galvanized, for use with wood framing and complying with Federal Specification FF-N-105B, Type 2, Style 20.

2. Screws: PermaBase Cement Board Hi-Lo thread screws (No. 8), wafer head, corrosion-resistant, 1-1/4" or 1-5/8" long, for use with wood framing and complying with ASTM C 1002.

3. Screws: PermaBase Cement Board drill point screws (No. 8) wafer head, corrosion-resistant, 1-1/4" or 1-5/8" long, for use with 20 to 14 ga. steel framing and complying with ASTM C 1002.

C. Joint Treatment:

1. Tape: Alkali-resistant fiberglass mesh tape for joint reinforcement, 2" wide mesh tape for interior applications and 4" wide mesh tape for exterior applications.

2. Bonding Materials: Latex-Portland cement mortar or Dry-Set (thin-set) mortar, for joint treatment and setting face material, complying with ANSI A118.1 or A118.4 standards. Type 1 organic adhesive meeting ANSI A136.1 may be utilized for interior use only.

PART 3 EXECUTION

3.01 INSTALLATION

A. General: In accordance with manufacturer's recommendations. National Gypsum Company "PermaBase Cement Board Construction Guide" and the following standard:

1. Installation of cementitious backer units: ANSI A108.11.

3.02 PROTECTION

A. Protect cement board installations from damage and deterioration until the date of substantial completion.

LIMITED WARRANTY AND REMEDIES

Products manufactured and sold by National Gypsum Company are warranted by National Gypsum Company to its customers to be free from defects in materials and workmanship at the time of shipment. THIS EXPRESS WARRANTY IS THE ONLY WARRANTY APPLICABLE TO SUCH PRODUCTS, AND IS IN LIEU OF AND EXCLUDES ALL OTHER EXPRESS ORAL OR WRITTEN WARRANTIES AND ALL IMPLIED WARRANTIES, INCLUDING BUT NOT LIMITED TO THE IMPLIED WARRANTIES OF MERCHANTABILITY AND FITNESS FOR A PARTICULAR PURPOSE.

National Gypsum Company will not be liable for any incidental, indirect or consequential losses, damages or expenses. The customer's exclusive remedy for any type of claim or action for defective products will be limited to the replacement of the products (in the form originally shipped) or, at National Gypsum's option, to a payment or credit not greater than the original purchase price of the products.

National Gypsum Company will not be liable for products claimed to be defective where the defect resulted from causes not within National Gypsum's control, or which arose or occurred after shipment, including but not limited to accidents, misuse, mishandling, improper installation, contamination or adulteration by other materials or goods, or abnormal conditions of temperature, moisture, dirt or corrosive matter.

Any claim that products sold by National Gypsum Company were defective or otherwise did not conform to the contract of sale is waived unless the customer submits it in writing to National Gypsum within thirty (30) days from the date the customer discovered or should have discovered the defect or nonconformance. No legal action or proceeding complaining of goods sold by National Gypsum may be brought by the customer more than one year after the date the customer discovered or should have discovered the defect or problem of which it complains.



National
Gypsum®

Index

A

Accessories	34, 47, 94
Acoustical testing	8
Adhesive nail-on of gypsum board	101, 102
Area separation walls	19, 20, 140
basement	143
clips	141
intermediate floors	142, 143
nonload-bearing	140
solid	140
top floor	142, 143
ASTM and Federal Specification product numbers	3

B

Banjo taper	69
Basecoat plasters	35
Bending radii	65, 75

C

CAD drawing information	Inside front cover, 161
Casing bead	34, 47, 94
Cavity Shaftwall system	123
for horizontal duct protection	26, 137
Ceiling board, high strength	61, 77
Ceiling panels, Gridstone BRAND	62, 86, 87, 88
Ceilings, steel frame	24-26, 40-42, 99
Ceilings, wood frame	22-24, 101
Cement board	145
Cement board, flexible	154
Cement board stucco wall system	151
Channels, steel	93
Chase wall	92
CleanRoom ceiling panels	62, 87
Column fireproofing	21, 39
Control joints	8, 47, 49, 71, 94
in ceilings	71
Cornerbead	34, 47, 94
Counters	149
Critical lighting areas	119
Curved surface, gypsum board over	65, 75

National 
Gypsum®

► **D**

Door frames92, 96
 Double layer gypsum board application104
 Double nailing101
 Drywall paper tape, used on joints50, 113, 119
 Drywall primer119, 120
 ProForm BRAND texture products.....115
 Duct protection26, 137

► **E**

e²XP Extended Exposure Sheathing.....31, 32
 Elevator doors128, 129, 136
 Environmental conditions for gypsum board.....63
 Expansion joints.....34, 47, 94
 Exterior soffit board60, 71
 E-Z Strip Control joint47, 94

► **F**

Face layer, application of gypsum board104
 Fasteners, gypsum board98, 101
 Federal specification designations7
 Federal specification product standards3
 Finish plasters36
 Finishing gypsum board112, 118, 119
 Fireproofing columns and beams21, 22, 39
 Fire-rated assemblies8-26
 Fire-Shield C gypsum board58, 66
 Fire-Shield plaster base34
 Fire-Shield shaftliner60, 110, 124, 137, 140
 Fire-Shield gypsum board58, 66
 Fire testing.....8
 Floating angle, wallboard application101, 102
 Floors
 steel framed24, 25
 wood framed22, 23
 Foam-insulated masonry108
 Foil back gypsum board89
 Furring channels99, 106
 for ceilings99
 splice99
 Z Furring.....53, 108

► **G**

Grid panels62, 86-88
 GridMarx64
 Gridstone BRAND ceiling panels62, 86-88
 Guide marks64
 Gypsolite plaster35
 Gypsum Board, see also Gypsum
 adhesive application102, 104
 application, adhesive nail-on method101, 102
 application, base layer97, 102
 application, double layer104
 application, floating angle method101
 application, over curved surface65, 75
 application, single layer97, 101
 board bending65, 75
 board fasteners98, 101

board finish guide118
 casing94
 cornerbeads94
 environmental conditions63
 gypsum board58, 65
 gypsum board products58
 limitations63
 lath/wood framing37
 mechanical application104
 over masonry109
 plaster systems33
 round-edged67
 R values65
 sag, causes of101
 screw application101, 102
 sheathing28-32, 59
 single-layer application97, 101, 102
 storage and handling63
 texture products115

► **H**

High Flex BRAND Gypsum Board60, 75
 High-strength ceiling board61, 77
 High-strength ceiling panels62, 88
 Hi-Abuse BRAND XP Gypsum board61, 78
 Hi-Impact BRAND XP Gypsum board61, 81
 Hopper69
 Horizontal duct protection26, 137
 Horizontal shaftwalls137
 H-stud area separation wall139

► **J**

J Track.....124, 125
 Joint compounds112
 ProForm BRAND All Purpose joint compound112
 ProForm BRAND Lite joint compound112
 ProForm BRAND Multi-Use joint compound112
 ProForm BRAND Sta-Smooth joint compound113
 ProForm BRAND Sta-Smooth Lite joint compound113
 ProForm BRAND Topping joint compound113
 ProForm BRAND Triple-T compound113
 ProForm BRAND Ultra joint compound.....112
 Joint tapes113
 Joint treatment products112, 113

► **K**

Kal-Kore45, 48, 1-54
 joints, treatment of50
 plaster base34, 46
 Kal-Kote44, 46
 basecoat plaster46
 over bonding agent44
 smooth finish46
 system over masonry53
 textured finish46
 used over Kal-Kore51
 Kal-Mesh tape47
 used on joints51

L

- Laminated partitions110
- Laminating adhesive, used in double-layer gypsum board104
- Lamination, gypsum board over masonry109
- Lath
 - ceilings, suspended40
 - gypsum/wood framing37
 - and plaster construction34
 - solid metal channel stud37
 - types of34
 - used in fireproofing39
- Levels of finish118
- Lighting, severe119
- Light steel frame partitions90
- Limiting heights91, 125, 126

M

- Metal framing93
- Metal lath, see Lath
- Metal lath, used in fireproofing columns and beams39
- Metric capability63
- Mold prevention63
- Multi-Flex tape bead113

N

- Nail pops102
 - repairing102
- Nonload-bearing steel frame partitions90
- Nonload-bearing walls90

O

- One-coat plaster
 - Uni-Kal44, 46, 53
 - X-KALibur44, 46, 53
- Orange Peel finish115

P

- Partition system for drywall90
- Partitions
 - Durasan18
 - shaftwalls, stairwells, area separation walls19, 20
 - solid19
 - steel framing14-18
 - steel framing (load-bearing)18
 - veneer plaster12
 - wood framing (load-bearing)12-14
- Perfect Spray115
- Perma Base BRAND cement board145
- Perma Base Flex BRAND cement board154
- Plaster
 - accessories34
 - basecoat35, 36
 - finish36

- gauging36
- Gypsolite plaster35
- moulding36
- painting36, 54
- systems33
- two-way hardwall35
- veneer12, 44, 50, 52
- Primer/sealer116
- Product specifications (directory)3
- ProForm BRAND joint compound112
- ProForm BRAND Sta-Smooth
 - joint compound113
 - gypsum board59, 67
 - HS113
 - lite compound113
- ProForm BRAND texture products115

R

- R-values, gypsum board65
- Ready-Mix joint compound113
- Resilient furring channels, see furring channels
- Runner
 - floor and ceiling93
 - L94

S

- Sagging gypsum board60 (see Soffit), 77, 101
- Saunas146
- Screw application, of gypsum board101
- Shaft construction
 - caulking136
 - drywall123
 - fire ratings19, 124
 - framing136
 - horizontal137
 - sound transmission data19, 124
 - wall heights allowed125-126
 - gypsum board136
- Shaftliner60, 110, 124, 137, 140
- Shaftwalls19, 124
- Sheathing, gypsum28, 31, 59
- Shelf brackets98
- Single-layer gypsum board application97, 101
- Soffit board, exterior60, 71
- Sound-rated assemblies8
- Solid laminated partitions110
- Solid-metal lath channel stud37
- Solid partitions19
- SoundBreak gypsum board84
- Sound reduction
 - with furring channels106
- Spatter finish115
- Spatter knockdown115
- Splice
 - furring channel99
 - stud99

Steel frame	
ceilings	24-26
floors	24-25
for drywall	90
partitions	12, 14-18
pitched roof truss	26
Steel studs	90
drywall partition system	90
nonload-bearing partitions	90
Steel track	93
Subfloor, deck	150
Subfloor, water resistant	149
Super-White Gauging Plaster	36
Super-White Moulding Plaster	36
Suspended ceilings	40, 99
metal lath	40

▶ **T**

Tape	47, 51, 113
Technical assistance number	Inside back cover
Testing	2, 8
Texture products	115
Toggle bolts	98
Trademarks	Inside front cover
Triple-T compound	113
Two-coat plaster Kal-Kote	44
Two-Way Hardwall plaster	35

▶ **U**

Underlayment, PermaBase	149
Uni-Kal BRAND	44
over bonding agent	50
applied over Kal-Kore	50

▶ **V**

Veneer plaster	12, 43
accessories	47
for metal and wood framing	50
over concrete	52
over masonry	53
systems	43
thickness	46

▶ **W**

Walls, wood frame	101
Warranty	Inside back cover
Wood framed	
floors and ceilings	22-24, 101
partitions	12
walls and ceilings	101

▶ **X**

X-KALibur	44-46, 50-53
XP Gypsum Board	70

▶ **Z**

Z furring channel	53, 54, 108, 109
-------------------------	------------------

INDEX OF CAD DETAIL DRAWINGS

DETAIL	DESCRIPTION	PAGE	DETAIL	DESCRIPTION	PAGE
06115A	Window Head Jamb – Reversible Stop	29	09250Q	Gypsum Board Partition at Floor	96
06115B	Window Head Jamb – 3/4" Blind Stop	29	09250R	Gypsum Board Partition End	96
09210A	2" Solid Plaster Partition Intersection	38	09250S	Gypsum Board Joint	96
09210B	2" Solid Plaster Partition Corner	38	09250T	Solid Laminated Partition at Floor	110
09210C	2" Solid Plaster Partition at Ceiling	38	09250U	Solid Laminated Partition Corner	110
09210D	2" Solid Plaster Partition with Metal Door Jamb	38	09250V	Solid Laminated Partition at Ceiling, Wall or Column	110
09210E	2" Solid Plaster Partition at Floor	38	09250W	Solid Laminated Partition with Wood Door Jamb	111
09210J	Metal Lath Three Hour Beam Protection	39	09250X	Solid Laminated Partition with Metal Door Jamb	111
09210J1	Column UL X402	39	09260A	Two Hour Fire Rated Shaftwall	128
09210K	Suspended Metal Lath at Wall (Unrestrained)	40	09260AA	Shaftwall Fireman Switch & Call Box	130
09210L	Suspended Metal Lath at Wall (Restrained)	41	09260B	Shaftwall Typical Start and End	128
09210M	Suspended Metal Lath Control Joint	40	09260BB	Shaftwall Call Box	130
09210N	Suspended Metal Lath at Wall (Unrestrained)	41	09260C	Shaftwall Outside Corner	127
09210O	Suspended Metal Lath at Lighting Troffer	40	09260CC	Shaftwall with Conduit	130
09210P	Furred Metal Lath Ceiling	41	09260D	Shaftwall Inside Corner	127
09210Q	Suspended Metal Lath	41	09260DD	Shaftwall Fireman Switch & Indicator Box	130
09210R	Suspended Metal Lath at Beam	41	09260E	Shaftwall 7'-0" Elevator Door Framing	128
09215A	Veneer Plaster Wood Stud Corner	49	09260EE	Shaftwall Chase Wall	134
09215B	Veneer Plaster Screw Stud Corner	49	09260F	Shaftwall 7'-0" Elevator Door Jamb	128
09215C	Veneer Plaster Joint	49	09260FF	Shaftwall Chase Wall	134
09215D	One Hour Fire Rated Control Joint	49	09260G	Shaftwall J Track Framing above 7'-0" Elevator Door	128
09215E	Suspended Veneer Plaster Control Joint	49	09260GG	Two Hour Fire Rated Horizontal Duct Protection	137
09250A	Exterior Soffit Board Ventilation	72	09260H	Shaftwall Elevator Door Head	128
09250B	Suspended Soffit Board at Wall	72	09260HH	Two Hour Fire Rated Corridor Ceiling & Stair Soffit	137
09250CC	Joint Where Wall Framing Changes	95	09260I	Shaftwall over 7'-0" Elevator Door Framing	129
09250E	Partition Intersection	95	09260II	One Hour Fire Rated Corridor Ceiling & Stair Soffit	137
09250F	Gypsum Board Partition Intersection	95	09260J	Shaftwall Elevator Door Jamb	129
09250G	Gypsum Board Partition Intersection (Alternate)	95	09260K	Shaftwall J Track Framing above Elevator Door	129
09250H	Gypsum Board Partition at Concrete Slab	96	09260L	Shaftwall Elevator Door Head	129
09250I	Gypsum Board Partition at Suspended Ceiling	96	09260M	Shaftwall at Suspended Ceiling (Unrestrained)	131
09250J	Gypsum Board Partition at Furred Ceiling	96	09260N	Shaftwall at Suspended Ceiling (Restrained)	131
09250K	Gypsum Board Partition with Wood Door Head	96	09260O	Shaftwall Mail Chute	131
09250L	Gypsum Board Partition with Metal Door Head	96	09260P	Shaftwall Cant Strip	131
09250M	Gypsum Board Partition with Control Joint	96			
09250N	Gypsum Board Partition Wood Door Jamb	96			
09250O	Gypsum Board Partition with Metal Door Jamb	96			
09250P	One Hour Fire Rated Control Joint	96			

INDEX OF CAD DETAIL DRAWINGS

DETAIL	DESCRIPTION	PAGE
09260Q	Shaftwall Parallel to Deck Valleys	132
09260R	Shaftwall Offset from Steel Beam	132
09260S	Stairwell Handrail Support (Screw Fastened)	133
09260T	Stairwell Handrail Support (Screw Fastened)	133
09260U	Stairwell Handrail Support (Bolt Fastened)	133
09260V	Shaftwall with Electrical Outlet	133
09260W	Shaftwall with Electrical Outlet Support	133
09260X	Stairwell Stair Hanger Rod	134
09260Y	Stairwell Stair Hanger Rod	134
09260Z	Shaftwall Elevator Electrical Control Layout	130
09265G	H-Stud Area Separation Wall	142
09265H	H-Stud Area Sep. Wall at Foundation	143
09265I	H-Stud Area Sep. Wall at Floor Intersection	142
09265J	H-Stud Area Sep. Wall at Roof Parapet	142
09265K	H-Stud Area Separation Wall at Roof	142
09265L	H-Stud Area Sep. Wall Protruding Ext. Wall	143
09265M	H-Stud Area Sep. Wall at Exterior Wall	142

QUICK SELECTOR CAD FILES

DETAIL	DESCRIPTION	PAGE
GOLDA.DWG or .DXF	Gypsum, Plaster, Metal Lath	11
GOLDB.DWG or .DXF	Plaster Fireproofing Columns (10WF49 or Heavier)	12
GOLDC.DWG or .DXF	Plaster Fireproofing Beams (8WF24 or Heavier)	12
GOLDD.DWG or .DXF	Veneer Plaster Partitions/ Wood Framing	12
GOLDE.DWG or .DXF	Veneer Plaster Partitions/ Steel Framing	12
GOLDH.DWG or .DXF	Gypsum Board Partitions/ Wood Framing (Load-Bearing)	12-14
GOLDJ.DWG or .DXF	Gypsum Board Partitions/ Steel Framing	14-18
GOLDK.DWG or .DXF	Gypsum Board Partitions/ Durasan Prefinished Gypsum	18
GOLDL.DWG or .DXF	Gypsum Board Partitions/Solid	19
GOLDM.DWG or .DXF	Gypsum Board Partitions/ Shaftwalls, Stairwells	19-20
GOLDN.DWG or .DXF	Gypsum Board Column Fireproofing	21-22
GOLDP.DWG or .DXF	Gypsum Board Floor/ Ceilings - Steel Framing	24-26
GOLDR.DWG or DXF	Gypsum Board Roof/ Ceilings - Steel Framing (pitched roof truss)	24-26
GOLDS.DWG or .DXF	Gypsum Board Floor Ceilings - Wood Framing	22-24
GOLDP.DWG or DXF	Gypsum Board Roof/ Ceilings - Steel Framing (Steel joists)	26
GOLDT.DWG or .DXF	Gypsum Board Horizontal Duct Protection	26

1-800 NATIONAL® HAS THE ANSWERS TO HELP YOU GET ON WITH THE JOB

FIELD REPRESENTATION

National Gypsum has a vast store of knowledge and experience to deal with virtually any problem or situation, and we've put that technical experience in the field with our representatives. Their job is to answer your questions and help you use the right products effectively, properly and productively.

Your National Gypsum Field Representative brings to each situation years of actual hands-on experience with gypsum and related products. Each Field Representative has also received extensive specialized training at the National Gypsum Research Center in evaluating specifications and meeting building code standards. So, before you start your next job, talk to your National Gypsum Field Representative to determine the products, the systems, the application procedures and the specifications needed to assure the job is done right, right from the start.

EXPERIENCE ON THE LINE!

When questions need to be answered immediately, National Gypsum's nationwide technical assistance hotline puts a wealth of experience and computerized data right at your fingertips.



1-800-NATIONAL
(800) 628-4662

LIMITED WARRANTY AND REMEDIES

Products manufactured and sold by National Gypsum Company are warranted by National Gypsum Company to its customers to be free from defects in materials and workmanship at the time of shipment. THIS EXPRESS WARRANTY IS THE ONLY WARRANTY APPLICABLE TO SUCH PRODUCTS, AND IS IN LIEU OF AND EXCLUDES ALL OTHER EXPRESS ORAL OR WRITTEN WARRANTIES AND ALL IMPLIED WARRANTIES, INCLUDING BUT NOT LIMITED TO THE IMPLIED WARRANTIES OF MERCHANTABILITY AND FITNESS FOR A PARTICULAR PURPOSE.

National Gypsum Company will not be liable for any incidental or consequential losses, damages or expenses. The customer's exclusive remedy for any type of claim or action for defective products will be limited to the replacement of the products (in the form originally shipped) or, at National Gypsum Company's option, to a payment or credit not greater than the original purchase price of the products.

A VALUABLE RESOURCE

With years of accumulated research, on-the-job experience and knowledge of building products and their application, National Gypsum's technical service experts are your resource for technical information. Beyond simply manufacturing and providing quality building products, National Gypsum has made a total commitment to technical assistance for our customers all along the line, at every stage of a project's development.

DIRECT AND IN PERSON

With one phone call from anywhere in the Continental U.S., Hawaii and Alaska or Canada, you have a direct, personal link to National Gypsum's database of current technical information. For your convenience, National Gypsum's toll free technical assistance is available from 8:00 a.m. through 4:45 p.m. (E.T.), Monday through Friday. They will get back to you within 48 hours with a specific and accurate answer to your gypsum application and installation problems. All with a single toll free phone call.



HOW CAN NATIONAL GYPSUM HELP YOU?

Ask us about specifications, code regulations, product usage, installation and more:

- Fire and sound rated walls and ceilings
- Metal stud height information
- Cavity shaftwalls, mechanical shafts, air ducts and stairwells
- PermaBase® BRAND cement board
- Durasan® BRAND prefinished vinyl gypsum wall panels
- Area separation walls acting as fire barriers for wood frame dwellings
- Levels of Gypsum Board Finish
- Veneer plaster systems, one and two coat
- Gridstone® BRAND vinyl laminated ceiling grid panels
- Lath and plaster construction
- ProForm® BRAND Joint Treatment products
- ProForm® BRAND spray textures for walls and ceilings
- Gold Bond® BRAND High Strength ceiling board
- ProForm® BRAND Sta-Smooth® FS-90 Fire-Shield® fire and smoke stop compound
- Gold Bond® BRAND Hi-Abuse® XP Gypsum Board
- Gold Bond® BRAND Hi-Impact® XP Gypsum Board
- Gold Bond® BRAND 1/4" High Flex® Gypsum Board
- Manufactured housing products and applications

National Gypsum Company will not be liable for products claimed to be defective where the defect resulted from causes not within National Gypsum Company's control, or which arose or occurred after shipment, including but not limited to accidents, misuse, mishandling, improper installation, contamination or adulteration by other materials or goods, or abnormal conditions of temperature, moisture, dirt or corrosive matter.

Any claim that products sold by National Gypsum Company were defective or otherwise did not conform to the contract of sale is waived unless the customer submits it in writing to National Gypsum Company within thirty (30) days from the date the customer discovered or should have discovered the defect or non-conformance. No legal action or proceeding complaining of goods sold by National Gypsum Company may be brought by the customer more than one year after the date the customer discovered or should have discovered the defect or problem of which it complains.

CUSTOMER SERVICE SALES AREAS

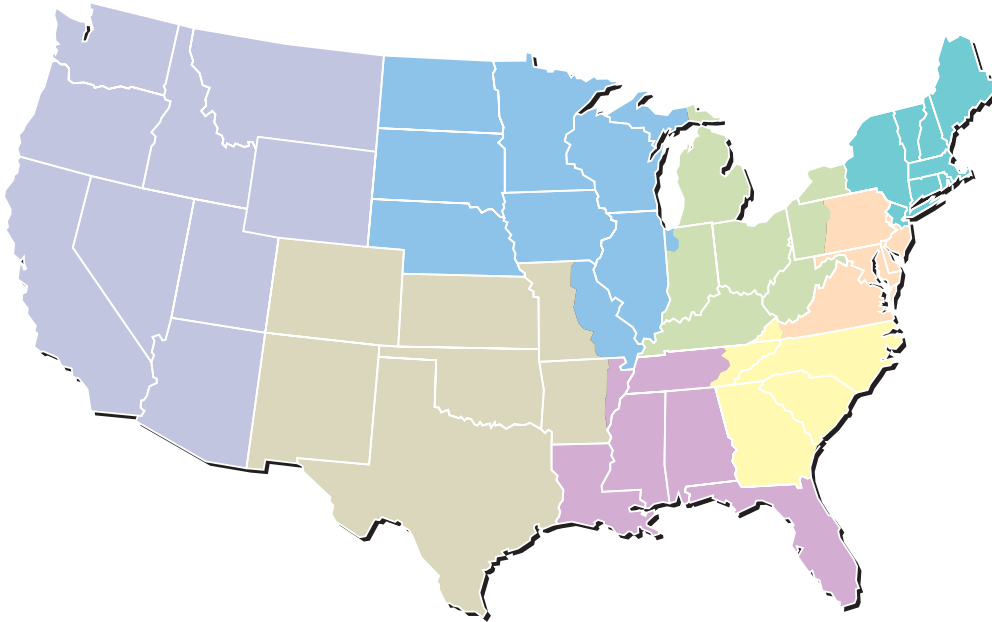

Atlantic Area

Ph: (800) 237-9167
Fx: (877) 252-0430

Central Area

Ph: (800) 252-1065
Fx: (866) 232-0440

Gulf Area

Ph: (800) 343-4893
Fx: (866) 482-8940

Midwest Area

Ph: (800) 323-1447
Fx: (866) 692-8590

Northeast Area

Ph: (800) 253-3161
Fx: (866) 632-1480

Southeast Area

Ph: (800) 548-9394
Fx: (866) 732-1990

Southwest Area

Ph: (800) 548-9396
Fx: (866) 792-7520

Western Area

Ph: (800) 824-4227
Fx: (800) 438-6266

National Accounts

Ph: (800) 440-1230
Fx: (866) 622-3590

Manufactured Housing

Ph: (800) 455-3185
Fx: (800) 639-1714

LIMITED WARRANTY AND REMEDIES

Products manufactured and sold by National Gypsum Company are warranted by National Gypsum Company to its customers to be free from defects in materials and workmanship at the time of shipment. THIS EXPRESS WARRANTY IS THE ONLY WARRANTY APPLICABLE TO SUCH PRODUCTS, AND IS IN LIEU OF AND EXCLUDES ALL OTHER EXPRESS ORAL OR WRITTEN WARRANTIES AND ALL IMPLIED WARRANTIES, INCLUDING BUT NOT LIMITED TO THE IMPLIED WARRANTIES OF MERCHANTABILITY AND FITNESS FOR A PARTICULAR PURPOSE.

National Gypsum Company will not be liable for any incidental, indirect or consequential losses, damages or expenses. The customer's exclusive remedy for any type of claim or action for defective products will be limited to the replacement of the products (in the form originally shipped) or, at National Gypsum's option, to a payment or credit not greater than the original purchase price of the products.

National Gypsum Company will not be liable for products claimed to be defective where the defect resulted from causes not within National Gypsum's control, or which arose or occurred after shipment, including but not limited to accidents, misuse, mishandling, improper installation, contamination or adulteration by other materials or goods, or abnormal conditions of temperature, moisture, dirt or corrosive matter.

Any claim that products sold by National Gypsum Company were defective or otherwise did not conform to the contract of sale is waived unless the customer submits it in writing to National Gypsum within thirty (30) days from the date the customer discovered or should have discovered the defect or nonconformance. No legal action or proceeding complaining of goods sold by National Gypsum may be brought by the customer more than one year after the date the customer discovered or should have discovered the defect or problem of which it complains.

Corporate Headquarters

National Gypsum Company
2001 Rexford Road
Charlotte, NC 28211
Phone: (704) 365-7300
Web: nationalgypsum.com
nationalgypsum.com/espanol

Technical Information

Phone: (800) NATIONAL
(800) 628-4662
Fax: (800) FAX-NGC1
(800) 329-6421

National 
Gypsum®

Excellence Across The Board®