

# 5-0 INSTALLATION

## TABLE OF CONTENTS

- 5-1 Overview of Installation Considerations ..... 5-3**
- 5-2 Pre-Installation Storage and Handling..... 5-4**
- 5-3 Line and Grade ..... 5-5**
- 5-4 Trench Excavation ..... 5-5**
- 5-5 Backfill Envelope Construction ..... 5-7**
  - Backfill Material ..... 5-8
  - Backfill Placement..... 5-11
  - Compaction ..... 5-15
  - Mechanical Compaction Equipment ..... 5-15
- 5-6 Joints ..... 5-17**
  - N-12<sup>®</sup> Plain End (soil-tight couplers)..... 5-17
  - N-12<sup>®</sup> ST IB (gasketed soil-tight couplers)..... 5-17
  - N-12<sup>®</sup> WT IB (gasketed watertight couplers) ..... 5-18
  - SaniTite<sup>®</sup> (gasketed watertight couplers) ..... 5-18
  - SaniTite<sup>®</sup> HP (gasketed watertight couplers)..... 5-18
  - N-12<sup>®</sup> Low Head (gasketed watertight couplers)..... 5-18
- 5-7 Other Installation Considerations ..... 5-20**
  - Construction and Paving Equipment..... 5-20
  - Joining Different Pipe Types or Sizes ..... 5-21
  - Field Connections ..... 5-21
  - Curvilinear Installations ..... 5-21
  - Manhole and Catch Basin Connections..... 5-22
  - Vertical Installations ..... 5-22
  - Groundwater..... 5-23
  - Flotation..... 5-23
  - Parallel Pipe Installations..... 5-25
  - Steep Slope Installations ..... 5-26
  - Cambered Installations ..... 5-26
  - Sliplining ..... 5-27
  - Post-Construction Inspection..... 5-27
- 5-8 Appendix A-5 ..... 5-29**
  - Other Technical Resources ..... 5-31

### Figures

- 5-1 Typical Subtrench Installation..... 5-7
- 5-2 Typical Backfill Structure..... 5-12
- 5-3 Rammer Compactors..... 5-15
- 5-4 Static Compactors..... 5-16
- 5-5 Vibrating Compactors ..... 5-16
- 5-6 Minimum Pipe Spacing ..... 5-25
- 5-7 Cambered Pipe Installations..... 5-27

**Tables**

5-1 Minimum Trench Widths .....5-5

5-2 Classes of Embedment and Backfill Materials .....5-10

5-3 General Recommendations for Installation and  
Use of Soils & Aggregates .....5-14

5-4 Compaction Equipment Selection Guide .....5-17

5-5 Guidelines for Joint Performance Selection .....5-19

5-6 Temporary Cover Requirements for Light Construction Traffic...5-20

5-7 Bending Radii for ADS Thermoplastic Pipe .....5-22

5-8 Approximate Weight of ADS Thermoplastic Pipes .....5-24

5-9 Minimum Cover Required to Prevent Flotation .....5-25

A-5-1 Available Product-Specific Technical Literature &  
Details Drawings.....5-29

A-5-2 Minimum Installation Requirements for ADS  
Thermoplastic Products .....5-30

*BUYER/USER IS RESPONSIBLE FOR SERVICEABILITY OF THE PRODUCT IN ANY GIVEN APPLICATION. SELLER IS NOT RESPONSIBLE FOR INJURY OR DAMAGE RESULTING FROM IMPROPER INSTALLATION, NONCOMPLIANCE WITH THESE GUIDELINES FOR INSTALLATION OF PRODUCT, OR USE OUTSIDE THE GUIDELINES SET FORTH HEREIN.*

## 5-1 OVERVIEW OF INSTALLATION CONSIDERATIONS

Installation of ADS pipe is in most respects very much like that of any quality pipe installation. The strength of a pipe system shall be considered a combination of the pipe itself and the backfill envelope. Proper construction maximizes the drainage capabilities designed into the pipe by maintaining alignment and load-carrying ability.

Recommendations for proper backfill and installation for ADS products are based primarily on the requirements of ASTM D2321 "Recommended Practice for Underground Installation of Flexible Thermoplastic Sewer Pipe". This handbook is not intended to replace standard industry or project specifications, but to provide guidance based on our experience, research and recommendations for proper product performance.

The elements regarding backfill that are addressed in this section are as follows:

**Proper backfill material selection** - A variety of materials can be used as structural backfill with the final decision, many times, based on what is most available locally. Native soil may be an appropriate material providing it meets the basic criteria established in this section.

**Proper backfill compaction** - Compaction forces out air and moisture to provide a more stable structure. Minimum compaction levels are based on the material characteristics and the design load; some situations may require the use of mechanical compactor while others require simply tamping the material to eliminate voids.

**Proper backfill structure** - An adequate quantity of structural backfill is necessary to ensure adequate support. Undisturbed native soil from a trench wall often provides additional support. Typical trench dimensions and the effect of the trench wall are discussed in this section.

In addition, this section discusses job-site handling, trench construction and pipe installation for ADS products, compaction methods, and several specialized installation considerations.

**Federal regulations covering safety for construction are published in the Safety and Health Regulations for Construction under the Department of Labor, Occupational Safety and Health Administration (OSHA). These regulations define practices, which must be followed.**

## 5-2 PRE-INSTALLATION STORAGE AND HANDLING

Thermoplastic pipes such as polyethylene and polypropylene are lightweight and easy to use. While no special care is needed in handling and installation a few precautions should be set forth.

- Follow all applicable safety regulations when handling pipe.
- The pipe shall not be dropped from the delivery truck into an open trench, or onto uneven surfaces.
- Avoid dragging or striking the pipe against another pipe or object.
- Avoid dragging the pipe across the ground.
- Do not drive over the pipe prior to installation.
- Inspect the pipe and joining systems before installation.

Many ADS drainage products are available palletized allowing for convenient transporting and orderly storage. If the products were not received on a pallet, the pipe should be carefully stacked. One method commonly used is to secure the bottom lengths of pipe together side-by-side, or use stop blocks, and then place additional pipe on top. Where pipe is stock piled, the total pile height shall not exceed 5-feet and the pipe must be adequately restrained to prevent pile collapse. Do not walk on stock piled pipe. Additional handling and storage information is available upon request.

Ambient temperature extremes do not affect the strength or handling characteristics of ADS pipe products. Cold temperatures can affect the impact resistance of some thermoplastics, although polyethylene and polypropylene remain highly impact resistant. In-house quality checks on polyethylene products demonstrate that the impact resistance at zero degrees F (-18C) is many times that required by specification. Additionally, hot weather, especially when coupled with direct sunlight, will raise the pipe temperature, but will not significantly affect handling or installation behavior.

Depending on the product, either carbon black or another UV stabilizer is added to the polyethylene or polypropylene to protect against ultraviolet light; unprotected plastic can become less impact resistant over time. Such additives are required by the specification and protect the pipe during storage periods at the manufacturing facility and at the job site. Ultraviolet light is no longer an issue after installation.

Long-term exposure to ultraviolet light causes slightly different results. The UV stabilizer protects the pipe for several years, after which the impact strength of the exposed layer, generally 0.001-inch (0.03mm), is significantly reduced. This damaged layer then functions in shielding the remainder of the pipe wall from any further damage. There are HDPE culverts, currently under observation, that were installed in 1974. The culverts have retained nearly all of their original strength characteristics and support strong evidence of continued service.

## 5-3 LINE AND GRADE

Storm drain and sewer pipe systems are designed to provide hydraulic capacity based on pipe size and slope. The alignment or line of the pipe is the horizontal location of the pipe while the grade is the vertical slope of the pipe. In order for a pipe system to function as designed, it is important to install the pipe to the proper line and grade.

Generally, no special practices are required to maintain line and grade; however, certain installation techniques can greatly increase the system performance and rate of installation.

Alignment is established by a field survey. Once the trench is excavated on line, the pipe bedding shall be placed to proper thickness. The top of the bedding shall be adjusted to allow for the difference between the plan invert (flowline) and pipe profile wall thickness. To determine the dimension to be subtracted from the pipe inverts indicated on the plans when checking bedding elevations measure the distance from the interior side of the liner to the crown of the corrugation.

## 5-4 TRENCH EXCAVATION

The width of the trench depends on the pipe diameter, backfill material, and the method of compaction. Trenches that are too narrow will not allow for proper pipe installation, whereas trenches that are overly wide are unnecessarily costly. As a practical matter, standard bucket sizes may also factor into the decision. The design engineer may modify the trench widths based on an evaluation of the competency of the in-situ materials, the quality and compaction level of the backfill, the design loads and the compaction equipment to be used. In lieu of the engineer's recommendations or governing agency specifications, the following trench widths are suggested in table 5-1.

**Table 5-1**  
**Minimum Trench Widths**

Nominal Pipe Diameter, in. (mm)	Minimum Trench in. (m)	Nominal Pipe Diameter, in. (mm)	Minimum Trench in. (m)
4 (100)	21 (0.5)	24 (600)	48 (1.2)
6 (150)	23 (0.6)	30 (750)	56 (1.4)
8 (200)	26 (0.7)	36 (900)	64 (1.6)
10 (250)	28 (0.7)	42 (1050)	72 (1.8)
12 (300)	30 (0.8)	48 (1200)	80 (2.0)
15 (375)	34 (0.9)	54 (1350)	88 (2.2)
18 (450)	39 (1.0)	60 (1500)	96 (2.4)

Trench widths should only be wide enough to permit the adequate placement and compaction of the embedment materials. This ideal trench width is normally referred to as the minimum trench width. It is designated in accordance with national standards and generally assures the width allows for backfill material to flow on either side of the pipe and permits the compaction of this material. If the width is not sufficiently wide for the materials and proposed compaction methods a wider trench allowing for proper installation shall be constructed.

In very poor native soils (for example; peat, muck, or highly expansive soils), a wider trench width with possibly filter fabric may be required. This wider trench width shall be based on an evaluation of the in-situ soil, and the design and construction loads.

Trench widths for pipe are often determined by the bucket size available for the excavator. In many cases, the bucket width can significantly exceed the ideal trench width. Wide trenches are not only costly to excavate and fill with backfill material they actually reduce the structural integrity of the pipe/backfill system. This fact is noted in the AASHTO *LRFD Bridge Construction Specification*, Section 30, "Trenches shall be kept to the specified width as any increase in trench width will increase the load on the pipe."

Years of consolidation create a very stable soil environment. The desire is to destroy as little of that stability as necessary when digging the trench. Stable trench walls actually enhance the structural integrity of the system when the trench is relatively narrow. Overly wide trenches also require more backfill material and more compaction which are typically not as stable as the undisturbed native material. A stable trench wall is characterized as one that can stand without support; however this does not refer to the possible need of trench wall supports to comply with OSHA.

It should be noted that although the pipe will have less load in a narrow trench condition, a wide trench application is used for the design methodology for thermoplastic pipe found in *AASHTO LRFD Bridge Design Specifications* Section 12. This point is clearly illustrated in Section 12.12, "narrow trenches yield a desirable level of conservatism, since the transfer of the load to in-situ trench wall is not considered in flexible pipe design."

The depth of the trench is dictated by the geography of the site and the pipe slope required. However, if an adequate foundation for the pipe is not available at the desired depth, additional excavation will be needed. Rock outcroppings, muck, and other unsuitable materials do not provide proper support. They shall be removed and replaced with suitable granular material. Refer also to Figure 5-1.

Trenching shall be completed in existing soils with sidewalls reasonably vertical to the top of the pipe. For positive projection embankment installations, the embankment material shall be placed and compacted to a minimum of one (1') foot above the pipe and the trench excavated into the embankment. When excavation depths or soil conditions require shoring or use of a trench box, the bottom of the shoring or trench box

shall be placed no lower than the top of the pipe. This prevents disruption of the backfill envelope when removing the shoring or trench box. Dragging the trench box shall only be done if it does not damage the pipe or disrupt the backfill, otherwise, the box shall be lifted vertically into its new position. If this practice cannot be followed, consideration should be given to leaving the shoring in place. Where the trench box must be located below the top of the pipe, the most effective way to maintain a sound system is to provide a 'sub trench' within which to place the pipe and backfill. For safety, the bottom of the trench box should not be greater than 24" above the bottom of the trench. For more information on the use of trench boxes, refer to Technical Note 5.01: *Recommended Use for Trench Boxes*.

**Figure 5-1**  
**Typical Sub Trench Installation**

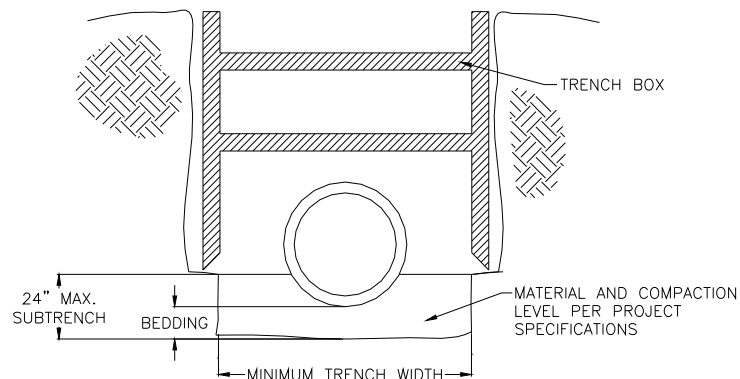

## 5-5 BACKFILL ENVELOPE CONSTRUCTION

Backfill construction shall be evaluated as part of the structural design of polyethylene and polypropylene pipe like it is for other pipe materials. ASTM D2321 serves as the basis for installation recommendations in trafficked installations. Acceptable backfill materials and construction methods are very similar or, in many cases, identical to those required for other types of pipe material.

The primary purpose of the backfill envelope is to provide long-term support to the pipe. In a properly constructed backfill envelope, the loads are distributed across the crown of the pipe to the material along the sides and then to the pipe bedding and foundation. This load arching effect reduces the total load applied to the pipe.

The load that a flexible pipe will carry is related to the backfill envelope construction. The load-carrying capacity of a pipe/backfill system will be determined by a combination of the backfill material, the level of compaction, and the placement of the backfill material. However, the type of application may also influence what type of backfill is required.

These and other related issues are discussed in subsequent paragraphs in this section.

## BACKFILL MATERIAL

Material selection is the first and most important step to creating a structurally sound backfill envelope. In general, backfill material should be of an aggregate nature, able to be compacted, if necessary, into a structurally sound structure. A variety of materials, including some native soils, meet these requirements.

Backfill offers passive resistance, termed the “modulus of soil reaction”. The modulus of soil reaction is determined by a combination of the material and the amount of compaction. The type of material (sand, gravel, clay, etc.) and compaction level (standard Proctor density) determine overall strength of the backfill. Some research indicates that other factors, such as the beneficial effects of trench walls, may add to the conservancy of the backfill strength, although those relationships are often neglected. (This information assumes the trench walls are at least as strong as the backfill material.)

The strength of the backfill can be described using different parameters. One way is by describing it in terms of the modulus of soil reaction ( $E'$ ), which is an empirical value developed by the Bureau of Reclamation to calculate deflection. Another parameter used to describe backfill strength is the secant constrained soil modulus ( $M_S$ ). Values for  $M_S$  and  $E'$  are discussed further in the Structures chapter of this handbook.

Recommendations for soil type and compaction level will vary based on the application and product; Appendix A-5 provides product-specific guidelines and literature references. Shallow, non-trafficked installations may not require the same level of backfill quality, but any modifications should be discussed with ADS engineers prior to establishing backfill criteria on a particular project. Installations involving higher loads sometimes require a higher soil strength; ADS engineers can also provide additional guidance on backfill requirements in these situations.

As discussed in the Structures section of this handbook, it is the combination of the type of material and compaction level that will determine the soil strength. When a variety of options will work in a particular installation, the final decision can depend on what is most available locally in order to keep the cost of the installation to a minimum. Native soil may be specified depending on the ADS product being installed, the application and when following the requirements of Table 5-2 and the respective technical literature as listed in Appendix A-5. Using native soil eliminates the cost of imported backfill material and the effort spent grading or hauling the excavated material off site. If the native material is not acceptable, then appropriate material will need to be brought in.

Controlled Low Strength Material (CLSM) or flowable fill is another, more specialized, type of backfill material that is increasing in use throughout

the country. This material is essentially very low strength concrete that is poured around the pipe. With CLSM or flowable fill, trench width can be reduced to a minimum of the outside diameter of the pipe plus 12-inches and the E' of the native material must be at least 1000 psi. Although the structural integrity of flowable fill is excellent, it will misalign or float the pipe unless precautions, such as weighting the pipe or pouring the flowable fill in layers, are taken. Conventional compacted granular material creates structurally sound backfill that is easier to use and often less expensive to install. For more information on the use of CLSM refer to Technical Note 5.02: *Flowable Fill Backfill for Pipe*.

**Table 5-2**  
**Classes of Embedment and Backfill Materials**

ASTM D2321 <sup>(A)</sup> Class	Description	Notation	ASTM D2487 Description	AASHTO M43 Notation	AASHTO M145 Notation	ASTM D2321 <sup>(A)</sup>											
						Percentage Passing Sieve Sizes				Atterberg Limits		Coefficients					
						1 ½ in. (40mm)	¾" (9.5mm)	No. 4 (4.75mm)	No. 200 (0.075mm)	LL	PI	Cu	Cc				
I <sup>(B)</sup>	Crushed rock, angular <sup>C</sup>	N/A	Angular crushed stone or rock, crushed gravel, crushed slag; large voids with little or no fines	5, 56, 57 <sup>(D)</sup> , 6, 67 <sup>(B)</sup>	N/A	100%	≤25%	≤15%	<12%	Non Plastic		N/A					
II	Clean, coarse-grained soils	GW	Well-graded gravel, gravel-sand mixtures; little or no fines	5, 6	A1, A3	100%	-	<50% of "Coarse Fraction"	<5%	Non Plastic	>4	1 to 3					
		GP	Poorly-graded gravels, gravel-sand mixtures; little or no fines	56, 57, 67							<4	<1 or >3					
		SW	Well-graded sands, gravelly sands; little or no fines								>6	1 to 3					
		SP <sup>F</sup>	Poorly-graded sands, gravelly sands; little or no fines								<6	<1 or >3					
	Coarse-Grained Soils, borderline clean to w/fines	GW-GC, SP-SM	Sands and gravels which are borderline between clean and with fines	N/A		100%	-	Varies	5% to 12%	Non Plastic	Same as for GW, GP, SW and SP						
III	Coarse-grained soils with fines	GM	Silty gravels, gravel-sand-silt mixtures	Gravel & sand with <10% fines	A-2-4, A-2-5, A-2-6, or A-4 or A-6 soils with more than 30% retained on #200 sieve	100%	-	<50% of "Coarse Fraction"	12% to 50%	N/A	<4 or <"A" Line	N/A					
		GC	Clayey gravels, gravel-sand-clay mixtures								<7 & >"A" Line						
		SM	Silty sands, sand-silt mixtures								>4 or <"A" Line						
		SC	Clayey sands, sand-clay mixtures								>7 & >"A" Line						
	Inorganic fine-grained soils	ML	Inorganic silts and very fine sands, rock flour, silty or clayey fine sands, silts with slight plasticity					100%			> 30% (Retained)		<50	<4 or <"A" Line			
		CL	Inorganic clays of low to medium plasticity; gravelly, sandy, or silty clays; lean clays								> 30% (Retained)		>7 & >"A" Line				
IV <sup>(E)</sup>	Inorganic fine-grained soils	ML	Inorganic silts and very fine sands, rock flour, silty or clayey fine sands, silts with slight plasticity	N/A	A-2-7 or A-4 or A-6 soils with 30% or less retained on #200 sieve	100%	-	100%	< 30% (Retained)	<50	<4 or <"A" Line	N/A					
		CL	Inorganic clays of low to medium plasticity; gravelly, sandy, or silty clays; lean clays	N/A					>7 & >"A" Line								
V <sup>(G)</sup>	Inorganic fine-grained soils	MH	Inorganic silts, micaceous or diatomaceous fine sandy or silty soils, elastic silts	N/A	A5, A7	100%	-	100%	>50%	>50	<"A" Line	N/A					
		CH	Inorganic clays of high plasticity, fat clays	N/A							>"A" Line						
	Organic soils or Highly organic soils	OL	Organic silts and organic silty clays of low plasticity	N/A							100%		-	100%	>50%	>50	<4 or <"A" Line
		OH	Organic clays of medium to high plasticity, organic silts	N/A													<"A" Line
		PT	Peat and other high organic soils	N/A													

Notes:

- A) Refer to ASTM D2321 for more complete soil descriptions.
- B) Class I materials allow for a broader range of fines than previous versions of D2321. When specifying class I material for infiltration systems, the engineering shall include a requirement for an acceptable level of fines.
- C) All particle faces shall be fractured.
- D) Assumes less than 25% passes the 3/8" sieve.
- E) Class IV materials require a geotechnical evaluation prior to use and should only be used as backfill under the guidance of a qualified engineer.
- F) Uniform fine sands (SP) with more than 50% passing a 100 sieve behave like silts and should be treated as Class III soils if allowed.
- G) Class V materials shall not be permitted as bedding and backfill material.

## Backfill Placement

Storm and sanitary sewers, as well as drainage lines are sometimes placed on foundations that settle and shift in a non-uniform manner. Fortunately, flexible pipe can accommodate many of these changes without detrimental effects. The best construction practices, however, involve placing the pipe on a firm foundation for maximum performance and structural integrity throughout the design life.

In some cases it may be necessary to perform subsurface evaluations of the soil conditions where muck, rock, or other unsuitable conditions are suspected. Zones of soft material, such as muck, allow the pipe to settle, potentially affecting the structural integrity and hydraulic characteristics of the system. Rock and rock protrusions apply point loads where they contact the pipe that can affect the hydraulics or structural integrity of the system. It is recommended that unsuitable foundation material be excavated before installation of the pipe proceeds. Where a rock or unyielding or soft foundation is present, the design engineer or a geotechnical engineer shall be consulted to determine the extent to which the undesirable material is to be excavated.

### Bedding

If no undesirable foundation material is found, a minimum of 4- to 6-inches (0.1 - 0.15m) of bedding shall be placed and compacted on the foundation to equalize load distributions along the invert of the pipe. Refer to Figure 5-2 for a pictorial description of backfill terminology.

A stable and uniform bedding shall be provided for the pipe and any protruding features of its joints and/or fittings. The middle of the bedding, under the pipe invert, equal to 1/3 of the pipe O.D. should be loosely placed, with the remainder compacted to minimum standard proctor density as listed in Appendix A, Table A-5-2. The same class of material recommended for the initial backfill is suitable for the bedding; however, the compaction requirements for the bedding may be higher than compaction requirements for the initial backfill to ensure the stability of line and grade. Refer to Appendix A-5, Table A-5-2 for product-specific installation recommendations for each zone.

Note: Where using open-graded material (class I with little fines for example) in any fill zone, additional precaution must be taken to reduce or eliminate the risk of migration of fines from adjacent material. Precautionary steps could include the use of geotextile between the varying fill materials, gradation selection to prevent the migration of fines, or other precautionary measures. Refer to ASTM D2321 for more complete information.

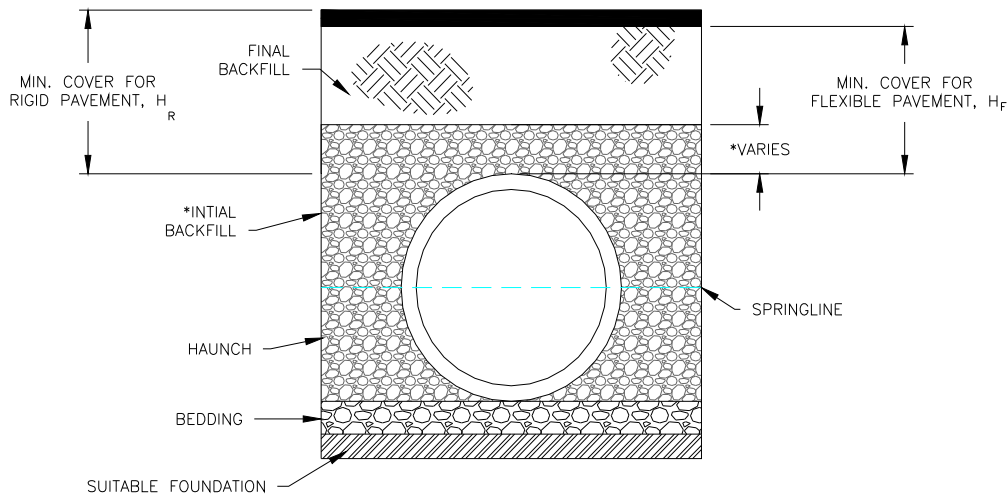

**Figure 5-2  
Typical Backfill Structure**



$H_R, H_F$  = 12" (0.15m) FOR PIPE DIAMETERS UP TO 48" (1200mm)  
 = 24" (0.6m) FOR PIPE DIAMETERS 54" (1350mm) AND 60" (1500mm)

BEDDING = 4" (100mm) MIN

\*INITIAL BACKFILL, TYPE AND AMOUNT ABOVE CROWN VARIES DEPENDING ON PRODUCT AND APPLICATION. SEE TABLE A-5-2 OF APPENDIX A-5 FOR DETAILS.

 FILL AS SPECIFIED BY DESIGN ENGINEER  
 STRUCTURAL BACKFILL (SEE NOTE)

STRUCTURAL BACKFILL  
 SEE TABLE A-5-2 OR APPENDIX A-5 FOR MATERIAL AND COMPACTION REQUIREMENTS BASED ON PIPE MATERIAL AND APPLICATION

**Haunch Backfill**

The next layer of backfill, the haunching, is the most important since it is this layer that provides the pipe with support against the soil and traffic loadings. Haunching shall be placed in lifts of 4- to 6-inches (0.10 - 0.15m) and compacted in accordance with product specific guidelines listed in Appendix A-5, Table A-5-2 to achieve required depth of fill. Construction of each lift should be repeated up to the spring line.

**Initial Backfill**

Initial backfill extends from the spring line, and depending on product and application, to the crown of the pipe or six inches (0.15m) above the crown of the pipe. This area of the backfill anchors the pipe and ensures that loads are distributed as evenly as possible into the haunching. The same material used in the haunching shall be used for the initial backfill. Where differing materials are used, backfill material size should be selected as to prevent migration of fines or a geosynthetic shall be used to separate the backfill zones. Additionally, it is crucial to obtain similar backfill strength between fill zones if differing materials are used. Using the same material throughout the embedment zone is recommended for all ADS products; however, using different materials between the haunch and initial backfill zones may be accomplished under strict guidelines that

are outlined in the appropriate product's fill height table technical note. See Table A-5-1 for a list of fill height table technical notes.

When using a material that requires compaction it is important not to use mechanical compaction equipment directly on the pipe itself. Initial backfill shall be placed in lifts of 4- to 6-inches (0.10 - 0.15m) and compacted in accordance with product-specific guidelines in Appendix A-5, Table A-5-2 to achieve required depth of fill. Tamp to achieve the specified compaction, or shovel into the area, eliminating voids, if the material doesn't require mechanical compaction. Construction of each lift should be repeated until the initial backfill zone is completed.

Flowable fill can be used throughout the pipe zone as an alternative to compacted granular material, however special precautions are necessary for a successful installation. Flowable fill may cause the pipe to float or misalign. Therefore the pipe will need to be weighted with sandbags or held with some type of anchoring system. The flowable fill may also be poured in layers that are allowed to cure before the next layer is poured to help reduce the tendency for the pipe to float. As with any backfill material, proper installation of the flowable fill around the pipe is critical to the structural performance of the pipe. For additional information on the use of flowable fill, refer to Technical Note 5.02: *Flowable Fill Backfill for Pipe*.

### Final Backfill

Final backfill, which extends from the initial backfill layer to the ground surface, does not directly support the pipe. Excavated materials may be of adequate quality for final backfill, depending on the intended use at the surface. Selection, placement and compaction of final backfill shall be as directed by the design engineer. When placing final backfill, consideration needs to be given to compaction equipment and construction loads operating over top of the pipe. Proper compaction of the final backfill area is not nearly so critical for the pipe as in the other layers; however, if roads or drives will be crossing the pipe, a relatively high degree of compaction is needed to prevent pavement settlement.

### Minimum Cover

For traffic applications total minimum cover is 12-inches (0.3m) for single run applications for 4- to 48-inch (100mm-1200mm) diameters pipe. For 54- and 60-inch (1350mm and 1500mm) diameter pipe total minimum cover is 24-inches (0.6m) for single run applications. Total minimum cover is measured from top of pipe to bottom of flexible pavement or to top of rigid pavement.

When no pavement will be installed, but vehicle traffic is expected (e.g. gravel driveway), a total minimum cover of 18-inches (0.5m) for 4- to 48-inch (100-1200mm) diameters and 30-inches (0.8m) for 54- and 60-inch (1350mm and 1500mm) diameters is recommended to minimize rutting. If the ground surface is truly green space or a landscape area, minimum cover may be 12-inches (0.3m) from top of pipe to ground surface for all diameters. These recommendations assume the pipe is installed in accordance with manufactures recommendations and may not address the cover needed to prevent flotation.

**Table 5-3**  
**General Recommendations for Installation and Use of Soils and Aggregates<sup>1</sup>**

Backfill Zone	Class 1	Class 2	Class 3 <sup>2</sup>
<b>General Restrictions</b>	Acceptable and common where no migration is probable or when combined with a geotextile filter media.	Where hydraulics gradient exists check gradation to minimize migration.	Do not use where water condition in trench may cause instability and/or prevent proper placement and compaction..
<b>Foundation</b>	√ Suitable as foundation and for replacing over-excavated and unstable trench bottoms as restricted above and as directed by design engineer.	√ Suitable as foundation and for replacing over-excavated and unstable trench bottoms as restricted above and as directed by design engineer.	√ Suitable as foundation and for replacing over-excavated and unstable trench bottoms as restricted above and as directed by design engineer.
<b>Bedding</b>	√ - 4" for 12"-24" pipe 6" for 30" to 60" pipe - Loosely place middle 1/3*OD with remainder compacted	√ - 4" for 12"-24" pipe 6" for 30" to 60" pipe - Loosely place middle 1/3*OD with remainder compacted	√ - 4" for 12"-24" pipe 6" for 30" to 60" pipe - Loosely place middle 1/3*OD with remainder compacted
<b>Haunch</b>	√ - Work in around pipe by hand to provide uniform support - knife in to remove any voids	√ - Work in around pipe by hand to provide uniform support - knife in to remove any voids	√ - Work in around pipe by hand to provide uniform support - knife in to remove any voids
<b>Initial Backfill</b>	√ - knife in to remove any voids	√	√
	For compaction and material recommendations, refer to product-specific guidelines in Appendix A-5, Table A-5-2		
<b>Relative Compaction Effort</b>	Low	Moderate	High
	For compaction and material recommendations, refer to product-specific guidelines in Appendix A-5, Table A-5-2		
<b>Final Backfill</b>	√ - Place and compact as required by the engineer	√ - Place and compact as required by the engineer	√ - Place and compact as required by the engineer

√ = Material may be suitable. Ultimately, the design engineer must determine the acceptable backfill material based on specific project conditions and structural requirements for the product.

- 1) Refer to ASTM D2321 for more complete soil requirements.
- 2) Class 3 is not recommended for all products. Refer to Appendix A-5, Table A-5-2 for product-specific recommendations.

## COMPACTION

The level of compaction will vary depending on the material and installation requirements, see product specific guidelines in Appendix A-5, Table A-5-2 for minimum compaction requirements based on soil type and application. Crushed stone or similar materials are usually not compacted, but do require care during installation to eliminate large voids in the backfill envelope. Using a shovel to 'slice' or 'knife' the material under and around the pipe is many times sufficient.

For other materials, compaction methods will depend primarily on the amount of compaction, or modulus of soil reaction, required and the moisture level of the material. At optimum moisture levels, some Class II and III soils can be compacted to minimum recommended levels simply by walking on each backfill lift. While this technique may not be acceptable for all installations, the point is that compaction need not always require a great deal of extra effort or mechanical equipment. If, however, mechanical compaction equipment is needed in the backfill envelope or elsewhere on the site, the subsequent paragraphs provide guidance on compaction equipment and the soils for which they are most appropriate.

## MECHANICAL COMPACTION EQUIPMENT

**Hand Tampers and Hand-Held Power Tampers:** Compaction of the haunch layer may require a small tamping mechanism to obtain the specified compaction in a confined area. A hand-held pole or two-by-four can be used to compact the haunching. Tampers for horizontal layers shall not weigh more than twenty pounds (89N) and the tamping face shall be limited to an area no larger than 6-inch by 6-inch (0.15 by 0.15m).

**Rammers or rammer plates (Figure 5-3):** Impact action is used to force out air and water from between soil particles to consolidate the fill. This equipment works well on cohesive or high-clay content soils. Care should be taken not to use rammer-type compactors directly on the pipe. For heavy-duty compaction equipment, such as a Ho-pac<sup>®</sup> or equivalent type compactors, a minimum of 4-feet (1.2m) of backfill shall separate the pipe from the equipment at all times.

**Figure 5-3**  
**Rammer Compactors**

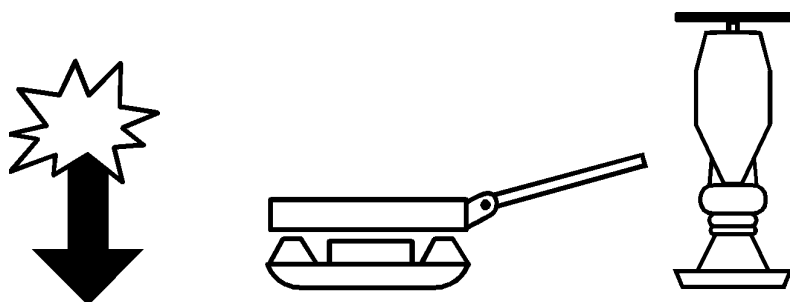

Static Compactors (Figure 5-4): Consolidation with static compactors occurs as a result of the rolling weight of the equipment itself. Sheeps-foot rollers employ projecting feet to concentrate the weight of the machine. Static compactors are most valuable when used on non-cohesive backfill away from the pipe. Other methods of compaction should be used near the pipe.

**Figure 5-4**  
**Static Compactors**



Vibrating Compactors (Figure 5-5): The motion of vibrating rollers or plates “shake” the soil particles into a more dense arrangement and works best with non-cohesive fills. Depending on the size and weight of the machine, vibrating compactors may be used close to the pipe. As always, care should be taken not to impact the pipe directly with a great deal of force.

**Figure 5-5**  
**Vibrating Compactors**

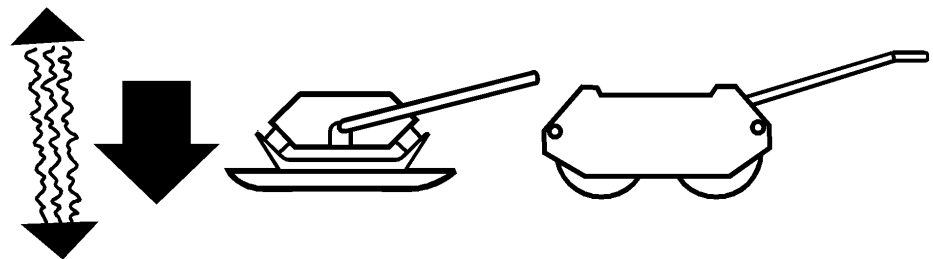

Selecting the right equipment for the fill material is the key to achieving the most efficient compaction. For soil mixtures, the component having the highest percentage will dictate what type of compaction equipment is needed. Table 5-4 provides guidance in the selection of compaction equipment.

**Table 5-4  
Compaction Equipment Selection Guide**

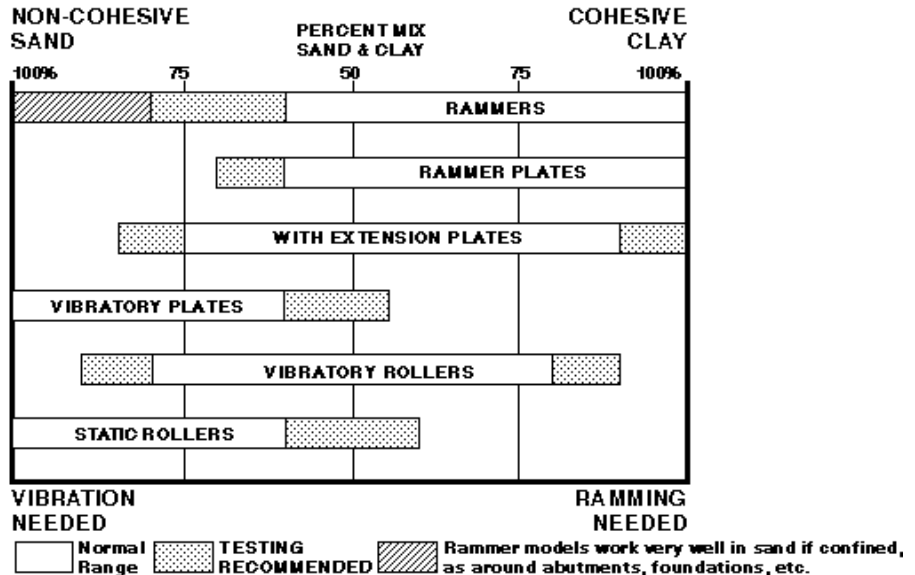

## 5-6 JOINTS

Joints serve several purposes in a pipe system. Their primary purpose is to preserve the structural integrity by keeping the embedment material out of the system. Well-designed joints also preserve the hydraulic properties of the pipe by maintaining alignment between pipe ends. Joints can keep effluent inside the pipe, which is necessary when environmental issues are a concern. Site-specific requirements or local regulations will usually dictate the performance of joint required. Joint configuration details are available in the respective product specification located in Section 1.

### N-12 PLAIN END(SOIL-TIGHT COUPLERS)

ADS N-12 plain end pipe joint use external coupling bands, such as a split band coupler, that meet the soil-tight requirements of AASHTO M252, AASHTO M294 or ASTM F2306. Typically, soil-tight joints are used with perforated systems where soil migration is not a design concern.

### N-12 ST IB (GASKETED SOIL-TIGHT COUPLERS)

The N-12 ST IB joining system is designed to perform in demanding soil conditions. The gasket meets all the testing requirements of ASTM F477. The gasket, combined with an interference fit, provides outstanding joint performance meeting or exceeding the soil-tight joint performance requirements of AASHTO M252, AASHTO M294, or ASTM F2306.

## **N-12 WT IB (GASKETED WATERTIGHT COUPLERS)**

The ADS 4- through 60-inch (100mm - 1500mm) N-12 WT IB joint meets the watertight joint performance requirements of AASHTO M252, AASHTO M294, and ASTM F2306. This joint shows no leakage when pressurized to 10.8 psi (74.5 kPa) under the laboratory conditions established in ASTM D3212.

This level of watertightness is recommended for systems that require a very tight joint for normal storm drainage conditions or other site and/or environmental reasons.

## **N-12 HP (GASKETED WATERTIGHT COUPLERS)**

The ADS 12- through 60-inch (300mm - 1500mm) N-12 HP meet the watertight joint performance requirements of ASTM D3212. This joint shows no leakage when pressurized to 10.8 psi (74.5 kPa) under the laboratory conditions.

This level of watertightness is recommended for systems that will be pressure tested, or that require a very tight joint for other site and/or environmental reasons.

## **SANITITE (GASKETED WATERTIGHT COUPLERS)**

The ADS 24- through 60-inch SaniTite joint meet the watertight joint performance requirements of AASHTO M252, AASHTO M294, and ASTM F2306. This joint shows no leakage when pressurized to 10.8 psi (74.5 kPa) under the laboratory conditions established in ASTM D3212.

This level of watertightness is recommended for systems that will be pressure tested to sanitary sewer standards, or that require a very tight joint for other site and/or environmental reasons. A longer bell design and two gaskets are used for SaniTite pipe.

## **SANITITE HP (GASKETED WATERTIGHT COUPLERS)**

The ADS 12- through 60-inch SaniTite HP joint meet the watertight joint performance requirements of ASTM D3212. This joint shows no leakage when pressurized to 10.8 psi (74.5 kPa) under the laboratory conditions established in ASTM D3212.

This level of watertightness is recommended for systems that will be pressure tested to sanitary sewer standards, or that require a very tight joint for other site and/or environmental reasons. A longer bell design and two gaskets are used for SaniTite HP pipe.

## **N-12 LOW HEAD (GASKETED WATERTIGHT COUPLERS)**

The ADS 24- through 60-inch (600mm - 1500mm) N-12 Low Head IB joint meet the watertight joint performance requirements of AASHTO M252, AASHTO M294, and ASTM F2306. This joint shows no leakage when pressurized to 10.8 psi (74.5 kPa) under the laboratory conditions established in ASTM D3212.

This level of watertightness is recommended for systems that will be under continuous pressures less than 5psi and surge pressures of 10psi

or that require a very tight joint for other site and/or environmental reasons. A longer bell configuration with two gaskets is used for N-12 Low Head pipe.

Guidelines for deciding what joint performance is appropriate in a particular application are provided in Table 5-5.

**Table 5-5**  
**Guidelines for Joint Performance Selection**

Joint Performance Options					
Project Conditions	Soil Tight		Water Tight		
	N-12 Plain End (4"-30")	N-12 ST IB Gasketed (4"-60")	N-12 WT IB (4"-60")	N-12 HP SaniTite or SaniTite HP (12"-60")	N-12 Low Head (24"-60")
<b>SOIL FACTORS</b>					
Potential for small or negligible soil migration (e.g., gravel, medium to coarse sands, cohesive soil).	√	√	√	√	√
Potential for moderate soil migration (e.g., fine sands, silts).	N/R	√	√	√	√
Potential for severe soil migration (e.g., very fine sands, non-cohesive fines).	N/R	N/R	√	√	√
<b>EFFLUENT CONDITIONS</b>					
Effluent is permitted to infiltrate into ground; poses little or no environmental concern.	√	√	√	√	√
Effluent has potential to cause groundwater or other contamination.	N/R	N/R	√	√	√
<b>PRESSURE CONDITIONS</b>					
Installation will operate under non-pressure conditions.	√	√	√	√	√
Installation will operate under non-pressure conditions; minimized leakage desired.	N/R	√	√	√	√
Installations with low temporary pressures due to operational events and ASTM D3212 joint quality required. Installed system to be hydrostatic pressure tested with an associated leakage allowance.	N/R	N/R	√	√	√
Installations with continuous pressure (≤5psi) or frequent surge pressure (≤10psi)	N/R	N/R	N/R	N/R	√

√ The most restrictive of the project conditions will ultimately determine minimum joint quality. Ultimately, the design engineer must determine the acceptable joint quality for the project.

N/R Not recommended by manufacturer. Final approval contingent on design engineer.

Where more than one product or joint design will be acceptable in a particular installation, the most cost effective alternative should be selected. Bell-and-spigot joints shorten installation duration and reduce labor because they require little time and effort to assemble; the result can be significant overall cost savings.

## 5-7 OTHER INSTALLATION CONSIDERATIONS

Not all drainage projects can be considered “typical” installations. Unusual soil conditions cannot always be found until the actual excavation is made. More complicated pipe configurations may be needed to arrive at the desired drainage pattern or to increase the capacity of an existing drainage network. ADS cannot anticipate all situations encountered on specific installations; however, several common questions are answered in the following material. Contact the ADS Applications Engineering Department or visit our website at [www.ads-pipe.com](http://www.ads-pipe.com) for answers to other unique conditions.

## CONSTRUCTION AND PAVING EQUIPMENT

Some construction vehicles, such as many types of paving equipment, are not as heavy as the design load. For situations with relatively light construction vehicles, the minimum cover criteria discussed in Section 2: *Structures* can be decreased during the construction phase; however, rutting may still occur at the surface. Table 5-6 presents the surface applied loads and the corresponding minimum cover that can be permitted on a temporary basis. *These criteria should only be employed during construction; finished projects should always meet minimum cover requirements for the anticipated final-use loading conditions. Vehicles exceeding criteria in Table 5-6 must not be permitted to drive over the installation.*

**Table 5-6**  
**Temporary Cover Requirements for Light Construction Traffic**

Type of Vehicle	Vehicular Load at Surface, psi(kPa)	Temporary Minimum Cover, in (mm) for:	
		4”-48” (100mm-12mm) Pipe	54”-60” (1350mm-1500mm) Pipe
Semi-tractor <sup>1</sup>	75 (517)	9 (230)	12 (300)
Loaded pick-up truck <sup>2</sup>	50 (345)	6 (150)	9 (230)
Skid steer loader <sup>3</sup>	25 (172)	3 (80)	6 (150)

1. Based on typical 3-axel day-trip tractor without trailer.

2. Chevy<sup>®</sup> 3500 Series, fully loaded

3. Bobcat<sup>®</sup> T180 Model skid steer loader

Very heavy construction traffic poses additional concern for buried flexible pipe when buried at shallow depths. The extremely high loads created by construction vehicles can potentially reduce the safety factors below reasonable levels in minimum cover conditions. It is recommended that three feet (0.9m) of cover be used over the pipe in installations involving construction vehicles between 30T and 60T (267-534kN). For heavier vehicles a greater amount cover is required. The amount of cover is dependent on the load and loading footprint. This additional cover can simply be mounded and compacted over the pipe during the construction phase and then graded following construction. If, in a particular

installation the pipe already has minimum amounts of cover, no additional precautions are needed.

## JOINING DIFFERENT PIPE TYPES OR SIZES

Drainage systems often involve connecting pipe of different materials or sizes. Options to make these transitions are often limited by the joint quality required. One very common method of connecting different types of pipe of the same size, and in some cases different sizes, is through the use of a concrete collar. This generally provides a minimum silt-tight joint quality but ultimately depends on workmanship. A concrete collar is formed by butting the two pipe ends together, wrapping the junction with a geotextile to keep out most soil and concrete, and then pouring a concrete collar that covers both pipe ends.

Another option may be using fittings or adapters specifically designed for this application. ADS offers a selection of fittings designed to make the transition from one material directly to another. In other cases an ADS fitting may need to be used in combination with another manufacturer's gasket to complete the transition. Transitions made in this manner may be more watertight than a concrete collar.

## FIELD CONNECTIONS

Field connections may be necessary to complete pipe runs for short pipe lengths or for repairs to pipe damaged during construction. Field connections and repairs should be performed with couplers compatible to the overall system. See Technical Note 5.03, 5.12 and 5.13 for *Thermoplastic Pipe Repair Options* for more details on field cuts and connections.

## CURVILINEAR INSTALLATIONS

ADS pipe can be laid on a curved alignment as a series of tangent (straight sections) deflected horizontally at each joint. However, the amount of joint articulation is dependent on the type of joint selected. See Table 5-7 for minimum bend radii based on joint type.

**Table 5-7**  
**Bend Radii for ADS Thermoplastic Pipe**

Pipe Diameter, In (mm)	Joint Type	Maximum Deflection at Joint (deg)	Radius, ft (m), per pipe length		
			10 ft (3m)	13 ft (4m)	20 ft (6m)
4 – 36 (100 – 900)	N-12 (split band or bell-bell couplers)	3	191 (58)	248 (76)	382 (116)
42 – 60 (1050 – 1500)	N-12 (split band or bell-bell couplers)	1.5	382 (117)	497 (152)	764 (233)
4 – 24 (100 – 600)	N-12 ST IB or N-12 WT IB (bell & spigot)	1.5	n/a	497 (152)	764 (233)
30 – 60 (750 – 1500)	N-12 ST IB or N-12 WT IB (bell & spigot)	1	n/a	745 (227)	1146 (349)
12 – 60 (300 – 1500)	N-12 HP, SaniTite, SaniTite HP or Low Head, (extended bell & spigot)	3	n/a	248 (76)	382 (116)

*Bend radii calculated with joint articulations only. Calculations do not assume any bend in the pipe wall. Joint deflections based on joint profiles and accounts for possible field variances.*

## MANHOLE AND CATCH BASIN CONNECTIONS

Manholes and catch basins can be more costly than other alternatives but also allow grade and directional changes in addition to changes in pipe material and size. Consideration shall be given to the project performance specified when selecting manhole connections. For connection options, refer to Appendix A, Table A-5-1 for list of list of technical literature associated with the appropriate product.

## VERTICAL INSTALLATIONS

ADS thermoplastic pipe is sometimes installed vertically for use as catch basins or manholes, meter pits, and similar applications. Vertical installations do not behave the same as pipe that is installed horizontally because the pipe/soil interaction is different. The soil surrounding a vertical pipe locks into the corrugations, allowing the pipe to move along with the soil consolidation that occurs over time. This movement can cause a rippling of the interior liner that generally does not affect the performance of the finished installation.

Installation requirements are especially important for vertical installations. Backfill material and compaction levels will determine the performance of the finished installation. Backfill shall extend a minimum of one-foot (0.3m) completely around the vertical structure. Only Class 1 or 2 backfill material is recommended and should be compacted to minimum 90% SPD.

Additional general applications limits include the following:

- Height of the vertical structure must not exceed eight feet (2.4m), unless the design is reviewed by the ADS Application Engineering Department.

- If traffic will be driving over a vertical structure, a concrete collar or similar structure designed to transmit the load into the ground must be used. Traffic loads must *not* be transmitted directly into the pipe wall.
- Cast iron frames holding grates or lids must be seated on a concrete collar or similar structure so that the weight of the frame and grate or lid is transferred into the ground, *not* to the vertical pipe.

Vertical installations of any ADS fitting should first be reviewed for suitability with ADS Application Engineering. This includes, but is not limited to, tees, elbows, and reducers of any combination. Improper application or inadequate installation may affect the function of the part or the drainage system. There may also be other product performance limits depending on the application. Contact ADS for further information.

## GROUNDWATER

Excessive groundwater hinders proper placement and compaction of bedding and backfill. ADS thermoplastic pipe will float in standing water; therefore, it is imperative that a dry trench be provided. In order to insure a stable trench bottom, the water level in the trench shall remain below the bedding during the installation procedure. It may be necessary to provide sump pumps, well points, deep wells, geofabrics, underdrains or a diversion ditch to insure a dry trench. The project engineer shall be consulted to determine appropriate dewatering methods given specific project conditions.

## FLOTATION

Pipe of any material and size can float under the right conditions. The soil type and density, amount of cover, height of the water table, pipe weight, and the amount of effluent in the pipe will all have an effect on the flotation potential.

The pipe property affecting flotation is its weight where heavier products are not as likely to float. One of the primary installation benefits of ADS polyethylene pipe is its light weight. The same quality that provides easy handling and installation also provides it with a greater opportunity to float. Table 5-8 gives approximate weights by inside diameter for ADS thermoplastic pipes.

**Table 5-8**  
**Approximate Weight of ADS Thermoplastic Pipes**

Inside Diameter in (mm)	Approximate Weight* lb/ft (kg/m)		
	Single Wall	Dual Wall	Triple Wall
4(100)	0.31 (0.46)	0.44 (0.65)	N/A
6(150)	0.58 (0.86)	0.85 (1.3)	N/A
8(200)	1.2 (1.8)	1.5 (2.2)	N/A
10(250)	1.8 (2.7)	2.3 (3.4)	N/A
12(300)	2.9 (4.3)	3.3 (4.9)	N/A
15(375)	4.0 (5.9)	4.6 (6.8)	N/A
18 (450)	6.0 (8.9)	6.4 (9.5)	N/A
24 (600)	11.2 (16.7)	11.0 (16.4)	N/A
30 (750)	N/A	15.4 (22.9)	20.7 (30.8)
36 (900)	N/A	19.8 (29.4)	24.2 (36.0)
42 (1050)	N/A	26.4 (39.3)	N/A
48 (1200)	N/A	31.3 (46.6)	41.8 (62.3)
54 (1350)	N/A	34.6 (51.5)	N/A
60 (1500)	N/A	45.2 (67.3)	55.0 (81.9)

\* Weights are for reference purposes only. Actual values will vary. For product-specific weights, contact an ADS Representative

In order to evaluate for possible flotation problems many factors were considered and several assumptions had to be made based on typical installation conditions. A detailed list of the design assumptions and other design considerations are available in Technical Note 5.05: Pipe Flotation. A summary of the fill required to prevent flotation is shown in Table 5-9. Note that in many cases, less than one foot (0.3m) is needed to prevent flotation but for structural purposes, minimum cover requirements will be greater based on pipe diameter and loading conditions. Due to many factors affecting flotation, several assumptions had to be made. For a detail list of the assumptions made, please refer to Technical Note 5.05: Pipe Flotation.

In spite of their light weight, ADS products will not float when adequate cover is placed on the pipe. Additionally, if effluent were in the pipe, as would be likely in the case of a fully saturated soil, its weight would further hinder flotation.

A second very important variable is the burial depth. During installation when the pipe has not yet been covered over with soil, flotation potential increases. If conditions on a specific project differ greatly from these and flotation is believed to be a valid consideration, ADS Application Engineers are available to help determine the extent of the problem.

**Table 5-9**  
**Minimum Cover Required to Prevent Flotation**

Diameter in. (mm)	Cover in. (mm)	
	Single Wall	Dual or Triple Wall
4 (100)	3 (77)	3 (77)
6 (150)	4 (102)	4 (102)
8 (200)	6 (152)	5 (127)
10 (250)	7 (178)	7 (178)
12 (300)	9 (368)	9 (368)
15 (375)	11 (457)	11 (457)
18 (450)	13 (559)	13 (559)
24 (600)	17 (711)	17 (711)
30 (750)	N/A	22 (914)
36 (900)	N/A	25 (1067)
42 (1050)	N/A	29 (1219)
48 (1200)	N/A	33 (1372)
60 (1500)	N/A	40 (1702)

## PARALLEL PIPE INSTALLATIONS

Sewer pipes can be installed parallel when the capacity supplied by one of the pipes is not sufficient, such as in a relief situation.

A minimum amount of backfill is needed to provide adequate side support and a minimum spacing is also needed to compact the fill properly to develop this support. Generally, accepted minimum spacings are shown in Figure 5-6. These recommendations assume there are no fittings connecting the two adjacent runs; if fittings are used, spacing recommendations will differ and are outlined in Section 6: *Retention/Detention*.

**Figure 5-6**  
**Minimum Pipe Spacing**

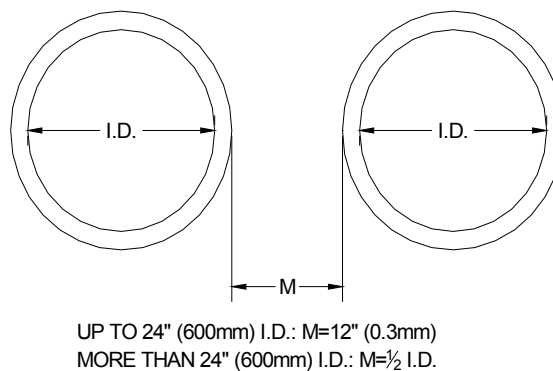

## STEEP SLOPE INSTALLATIONS

In applications where a steep slope is necessary, generally slopes equal to or greater than 12%, precaution must be taken to ensure the application conditions will not adversely affect the pipe structure or flow characteristics. One design consideration should be proper venting. The pipe must be properly vented to ensure negative pressure does not form inside the pipe. Venting can be provided along the pipe slope, at the head of the slope, or by designing the flow in the slope to not flow more than 75% full in peak design flow conditions. Next, thrust blocks must be used at all fittings and grade changes. Change in flow direction can cause excessive force against the pipe wall; therefore thrust blocks must be used to dissipate this energy. Thrust blocks should be constructed as designed and specified by the project engineer for the specific project conditions. Finally, consideration must be given to pipe slippage along the slope. Pipe slippage can result in slope failure of the surrounding soil, structural damage of the pipe wall, or compromising of joint quality for the overall system. Pipe should be restrained through the use of concrete blocks or pipe anchors.

Note: Twelve percent grade is listed for reference purposes only, additional design consideration may be necessary for slopes less than 12% where slope stabilization, negative pressure, or water hammer, may be of concern.

## CAMBERED INSTALLATIONS

Some pipe installations may need to design for uneven settlement regardless of the backfill envelope quality and construction. High embankments are especially prone to uneven settlement because the load on the pipe near the center of the embankment will be greater than at the top of the slope. In order to eliminate low pockets under the embankment, the pipe should be cambered.

Cambering is the process of installing the pipe so that the expected settlement will create the design slope. It can be achieved by installing the upstream half of the pipe on a flat grade and downstream half on a grade that is larger than design, as shown in Figure 5-7. Corrugated pipe, because of its flexibility, can be cambered quite easily. A qualified soils engineer should be consulted for this specialized situation.

**Figure 5-7**  
**Cambered Pipe Installations**

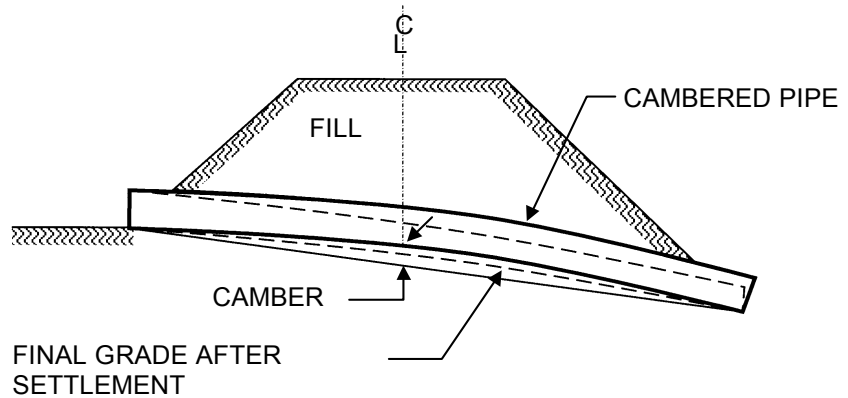

## SLIPLINING

Due to abrasive or corrosive environments, premature deterioration of some types of pipe may occur. In lieu of a total replacement, sliplining the existing pipe with ADS thermoplastic pipe is often an economical and efficient way to significantly extend a culverts' service life. Typically, ADS thermoplastic pipe can only be used for open-ended applications where the pipe does not need to be bent for installation. Other considerations during design and pre-construction should include the inside and outside diameter of the carrier pipe and new slipline pipe, length of installation and grout installation. For more information, refer to Technical Notes 5.06, and 5.14, *Sliplining Considerations* for more details.

## POST-CONSTRUCTION INSPECTION

Generally, no post construction is necessary for ADS pipe installations; however it is good practice to perform a visual inspection to insure proper line and grade have been achieved. It is important to understand that under normal conditions, any deflection will be realized within the first thirty (30) days after installation. This affords the inspector the opportunity to inspect the pipe shortly after installation with the ability to note deficiencies before the project is complete. The inspection should be performed after the pipe has been laid and backfilled, but may be before final paving has been placed.

The following outlines various inspection methods commonly specified for flexible pipes (plastic or metal). Additional post-installation inspection and testing information is available in Technical Note 5.07: *Post Installation Deflection Testing*, Technical Note 5.08: *Laser Profiling of Flexible Pipe*, and 5.17: *Field Testing SaniTite HP pipe*.

## Visual Inspection

A visual inspection will usually reveal improper line and grade as well as excessive deflection. For most projects, which specify a soil-tight or silt-tight joint performance, a visual inspection is sufficient to insure a successful installation. Caution is advised when inspecting pipe or entering manhole or inlet structures to insure compliance with all OSHA regulations.

## Infiltration/Exfiltration Testing

For systems designed for watertight applications without specifying any ASTM specification for testing, an infiltration/exfiltration test is a simple and easy method of insuring proper joint performance. For an exfiltration test, a run of piping is tested by filling the system with water from structure to structure (manhole or inlets), with appropriate bulk heads or pipe bladders to seal off the pipe from the structure. Allow the system to stabilize for 24 hours, measuring the water level at the beginning of the test and then measuring the water level again after a specified period of time. The drop in water level can then be converted to gallons leakage/ inch pipe diameter/ mile length of pipe /day and compared to the permissible level established for the project. In the absence of a specified level, 200-gal/ in. dia. of pipe/ mi of sewer/ day is commonly considered watertight for storm and sanitary sewer applications. An acceptable ASTM specification for testing infiltration/exfiltration is ASTM F2487.

## Air Testing

After the pipe has been laid and backfilled, each section of the pipeline between manholes may be tested using standard procedures for a low pressure air test. Individual joints may also be tested with appropriate equipment. This test is usually for systems where performance standards require watertight joints. ASTM F-1417 may be used for air testing these systems and shall be completed from structure to structure or for individual joints. Fabricated structures and fittings shall not be tested to avoid damaging these components.

ASTM F1417 specifies a 3.5 psi air pressure be held for a specified length of time based on the pipe diameter with a maximum 0.5 psi pressure drop. Although the diameters listed in ASTM F1417 only include up to 36-inch (900mm), linear interpolation for larger diameters is generally acceptable. ADS does not recommend air testing of any pipe diameters 24-inch (600mm) or larger due to the potential significant safety risks from the stored energy created and nature of the test method.

## 5-8 APPENDIX A-5

**Table A-5-1**  
**Available Product-Specific Technical Literature & Details Drawings**

	Storm Sewer			Sanitary Sewer		Irrigation
<b>Product</b>	N-12 Pipe per ASTM F2306 /AASHTO	N-12 Pipe & Mega Green per ASTM F2648	N-12 HP	Sanitite®	Sanitite® HP	N-12 Low Head Pipe
<b>Minimum &amp; Maximum Cover</b>	Technical Note 2.01	Technical Note 2.02	Technical Note 2.04	Technical Note 2.01	Technical Note 2.05	Technical Note 2.01
<b>Trench Installation Details</b>	STD-101	STD-101	STD-108, 109	STD-101	STD-110	STD-101
<b>Connections to Manholes &amp; Structures</b>	201, 202 series, 203, 204 series	201, 202 series, 203, 204 series	206 series, 207 series	204 series	205 series	204 series

**Table A-5-2**  
**Minimum Installation Requirements for ADS Thermoplastic Products**

		<b>AASHTO or ASTM F2306</b>	<b>ASTM F2648 or Mega Green</b>	<b>N-12 HP for Storm Drainage</b>	<b>SaniTite &amp; SaniTite HP for Sanitary Sewer</b>	<b>N-12 Low Head</b>
<b>Minimum Cover (≤2-ft) Backfill Recommendations</b>	<b>Bedding</b>	Class 1, 2 or 3 loosely placed in middle 1/3, 90% SPD in remainder	Class 1 or 2 loosely placed in middle 1/3, 90% SPD in remainder	Class 1, 2 or 3 loosely placed in middle 1/3, Class 1 or 2, 90% SPD or Class 3, 95% SPD in remainder	Class 1 or 2 loosely placed in middle 1/3, 90% SPD in remainder	Class 1 or 2 loosely placed in middle 1/3, 90% SPD in remainder
	<b>Haunch &amp; Initial Backfill</b>	Class 1 Class 2 @ 90% Class 3 @ 90%	Class 1 compact Class 2 @ 90%	Class 1 Class 2 @ 90% Class 3 @ 95%	Class 1 compact Class 2 @ 90%	Class 1 compact Class 2 @ 90%
<b>Maximum Cover Backfill Recommendations</b>	<b>Bedding</b>	Class 1, 2 or 3 loosely placed in middle 1/3, 90% SPD in remainder	Class 1, 2 or 3 loosely placed in middle 1/3, Class 1 or 2, 90% SPD or Class 3, 95% SPD in remainder	Class 1, 2 or 3 loosely placed in middle 1/3, 90% SPD in remainder	Class 1 or 2 loosely placed in middle 1/3, 90% SPD in remainder	Class 1 or 2 loosely placed in middle 1/3, 90% SPD in remainder
	<b>Haunch &amp; Initial Backfill</b>	Class 1 Class 2 @ 85% Class 3 @ 85%	Class 1 compact Class 2 @ 90% Class 3 @ 95%	Class 1 Class 2 @ 85% Class 3 @ 85%	Class 1 compact Class 2 @ 90%	Class 1 compact Class 2 @ 85%

- 1) Table provides minimum compaction levels for the respective soil class; higher compaction levels than stated are acceptable and may be necessary depending on fill height.
- 2) For additional information, refer to the product specific Technical Note on minimum & maximum cover recommendations.

## OTHER TECHNICAL RESOURCES

(APPLICABLE TO ALL ADS PRODUCTS)

### ADS Technical Notes

- Technical Note 5.01: *Recommended Use of Trench Boxes*
- Technical Note 5.02: *Flowable Fill Backfill for Thermoplastic Pipe*
- Technical Note 5.03: *Pipe Repair Options*
- Technical Note 5.04: *Connections to Manholes and Structures*
- Technical Note 5.05: *Pipe Flotation*
- Technical Note 5.06: *Sliplining Considerations*
- Technical Note 5.07: *Post-Installation Deflection Testing*
- Technical Note 5.08: *Laser Profiling of Flexible Pipe*
- Technical Note 5.09: *Utility Crossings*
- Technical Note 5.10: *Integral Bell Transition*
- Technical Note 5.11: *Sliplining Considerations for Extended Lengths*
- Technical Note 5.12: *Repair Methods for N-12 HP Storm Pipe*
- Technical Note 5.13: *Repair Methods for SaniTite HP Pipe*
- Technical Note 5.14: *Culvert Sliplining with HP Pipe*
- Technical Note 5.15: *Integral Bell Transitions for N-12 HP pipe*
- Technical Note 5.16: *Methods for Sealing Vent Tubes*
- Technical Note 5.17: *Post Installation Testing of SaniTite HP*

### ADS Standard Details

- Standard Detail 1.06: *Parallel Pipe Installation*
  - Standard Detail 1.07: *Flowable Fill Installation*
  - Standard Detail 1.08: *Pipe Anchoring Systems*
- Additional details are available at [www.ads-pipe.com](http://www.ads-pipe.com)