

WOODWORKS® Vector®

Installation Instructions

1. GENERAL

1.1. Product Description

WoodWorks Vector ceilings consist of perforated and unperforated panels that are downward accessible, and are designed to be installed on a conventional 15/16" wide T-bar suspension system. Available sizes are 1' x 4', 2' x 2', and 2' x 4'. All full panels can be removed and re-installed without the need for access to the plenum. Only two sides support installed panels. These edges have specially designed kerf details, which allow one edge of the panel to be raised slightly off of the grid flange, and then moved out of position. The other two sides are fitted with rabbeted edges, which work to center the panel within the grid opening.

1.2. Surface Finish

All wood panels are constructed of wood chips factory bonded together between 2 layers of wood veneer finish. All exposed edges are banded with the same finish as the face.

1.3. Storage and Handling

Ceiling components should be stored in a dry interior location and shall remain in cartons prior to installation to avoid damage. The cartons should be stored in a flat, horizontal position. The protectors between panels should not be removed until installation. Proper care must be taken when handling to avoid damage and soiling. Do not store in unconditioned spaces with humidity greater than 55% or lower than 25% RH and temperatures lower than 50°F or greater than 86°F. Panels must not be exposed to extreme temperatures, for example, close to a heating source or near a window where there is direct sunlight. **NOTE:** Vector panels feature exposed edges. Exercise appropriate care to avoid unnecessary contact with the panel edges. Remember that the grid flanges will not conceal panel edge damage.

1.4. Site Conditions

WoodWorks Vector ceiling should be permitted to reach room temperature and have a stabilized moisture content for minimum of 72 hours before installation. (Remove plastic wrap to allow panels to climatize). They should not, however, be installed in spaces where the temperature or humidity conditions vary greatly from the temperatures and conditions that will be normal in the occupied space.

1.4.1. HVAC Design & Operation

Proper design for both supply air and return air, maintenance of the HVAC filters, and building interior space are essential to minimize soiling. Before starting the HVAC system, make sure air supply is properly filtered and the building interior is free of construction dust.

1.4.2. Temperature & Humidity During Installation

WoodWorks ceiling panels are interior finish products that are designed for installation to be carried out in temperature conditions between 50°F (10°C) and 86°F (30°C), in spaces where the building is enclosed and HVAC systems are functioning and will be in continuous operation. Relative humidity shall not fall below 25% or exceed 55%. Additionally, the fluctuation in relative humidity shall not vary more than 30% over the life of the ceiling panels. There shall be proper ventilation of the plenum in high moisture areas. All plastering, concrete, terrazzo or any other wet work shall be completely dry. All window and doors shall be in place. The heating, ventilation and air-conditioning system should be installed and operable where necessary to maintain proper temperature before, during and after installation of the WoodWorks panels.

1.4.3. Plenum

Installation of Vector panels requires a minimum of space in the plenum, primarily that which is required to install the hanger wires for the suspension system. Three inches (3") is generally accepted as the minimum practical space that is needed to attach these wires. **NOTE:** Light fixtures and air handling systems require more space and will determine the minimum plenum height for the installation.

1.5. Color

WoodWorks panels are made with a variety of real wood veneers. Natural variations in color and grain are characteristic of wood products. To maximize visual consistency, panels should be unpacked and examined collectively to determine the most desirable arrangement for installation. Where consistency is critical, Armstrong can offer custom solutions to meet your budget and aesthetic requirements. Consult HPVA for additional information on veneers and veneer grades.

2. PANEL EDGES

2.1. General

The edges of the Vector panels feature unique detailing. The following section is intended to define and explain the function of the edge details.

2.2. Access Kerf Edge

The panel edge designated as "A" has a stepped groove detail and is called the access kerf. This edge is the first to engage the suspension system. Review the drawings below to familiarize yourself with this unique detail. Remember that the "A" edge is always installed first. This panel edge is also the one that must rise when the ceiling must be accessed.



2.3. Registration Kerf

Edge "B" has a single kerf detail that supports the second side and centers the panel in the A – B direction. This edge is referred to as the registration kerf and is opposite edge "A".

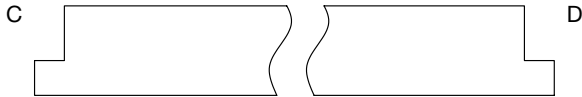

2.4. Reverse Tegular Edges

The two remaining panel edges are rabbeted to fit between the flanges of the grid system. These edges center the panel in the C - D direction and are called reverse tegular edges.

3. SUSPENSION SYSTEM

3.1. General

Pay close attention to these instructions. 1' x 4' and 2' x 2' panels can be installed in a conventional grid layout with main beams at 4' centers. 2' x 4' panels require main beams installed at 2' centers. Follow the guidelines in section 3.3 for 2' x 2' panels and section 3.4 for 2' x 4' panels. The suspension system shall be standard 15/16" exposed tee grid. The installation shall, in all cases, conform to the requirements of the International Building Code and its referenced standards. Because these panels weigh in excess of 2.5 lb/sf, the ceilings shall be installed per IBC Seismic Design Categories D, E, and F. Included in these requirements is the use of stabilizer bars or some other means to positively prevent the grid from separating at the walls. Additionally, walls or soffits that serve to support a panel edge must be braced to structure so as not to allow movement greater than 1/8" when subjected to design lateral force loads. When such bracing is not practical or is not effective additional mechanically connected grid components shall be provided to capture all edges of every panel. Axiom perimeter trim connected to the grid with AXTBC clips will also meet this requirement. The requirements listed here represent the manufacturer's minimum acceptable installation recommendations, and may be subject to additional requirements established by the local authority having jurisdiction.

3.2. Suspension Grid

For 1' x 4' and 2' x 2' Vector Panels, the main beams shall be spaced 48" o.c. The 48" cross tees shall intersect the main beams at 90° every 24" for 2' x 2' panels and every 12" for 1' x 4' panels. The 24" cross tees shall be installed at the midpoints of the 48" tees. When 2' x 2' panels are to be used, hanger wires shall be installed not more than 48" on center along the length of the main beams. **The suspension system must be leveled to within 1/4" in 10' and must be square to within 1/16" in 2'.** Installation on grid systems that do not meet this tolerance will produce unacceptable panel alignment.

3.3. Suspension Grid for 2' x 4' Panels

Main beams shall be spaced 24" on center. 2' cross tees shall intersect the main beams at 90 degrees every 48". Hanger wires shall be not more than 48" on center along the length of the main beams.

3.4. Safety Clips

The weight of the panels and the downward nature of the access suggest the need for a mechanism to prevent panels from dropping when disengaged from the grid. Two safety clips are provided for each 2' x 2' panel. All other size panels require four clips per panel. Clips and screws for 2' x 2' panels are included in the carton. Clips for all other sizes are included, but shipped separately. These clips must be attached to each panel by means of the #8 x 9/16" screws provided. Pre-drilled pilot holes are located along each kerfed edge of the panel.

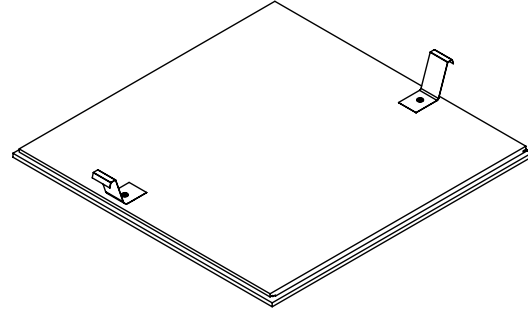

3.5. Seismic Hold Down Clips

Seismic Hold Down Clips are required for all installations. Two clips for 2' panels, three for 4' panels. Locate a clip near each end of the kerfed edge and then at 2' centers. Clips for 2' x 2' panels are included in the carton. For all other sizes, clips are provided but shipped separately. Clips should be applied to the grid before the placement of the panels.

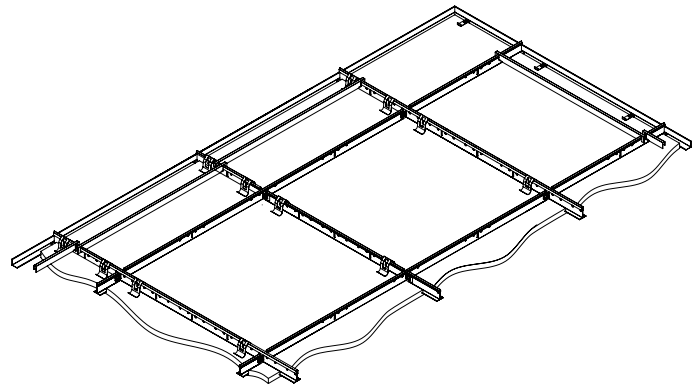

3.6. Panel Face Offset

The face of the Vector panel extends 7/16" below the suspension system. The height of components that interface with the ceiling panels, such as sprinkler heads and light fixture trim rings, will have to be adjusted to accommodate this 7/16" offset.

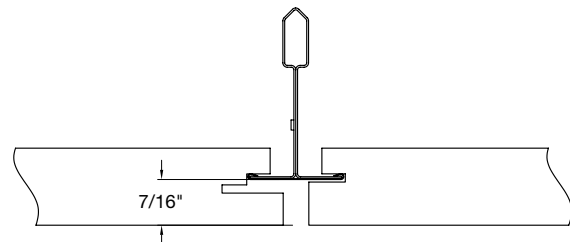

3.7. Panel Penetrations

Holes cut for sprinkler heads and other services that penetrate the ceiling panel must be cut slightly oval shaped to allow the panel to move 1/4" in the direction of the "A" edge. Additionally, trim rings for these devices must be wide enough to accommodate this 1/4" movement.

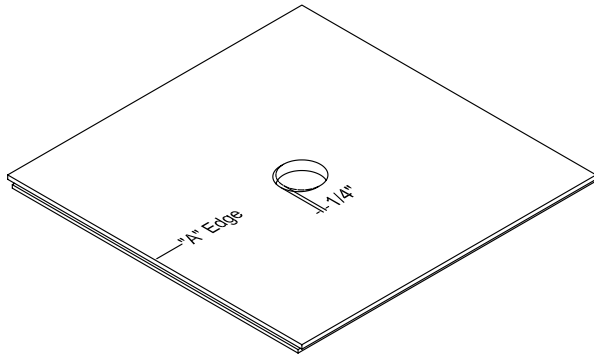

4. PANEL INSTALLATION AND REMOVAL

4.1. General

Vector ceiling panels are easily installed and removed from below the suspension system without the aid of tools or special equipment, allowing easy downward access to the plenum.

4.2. Installing Full-Size Panels

The Vector panels are installed in a simple three-step process.

STEP 1: Fully insert the deepest kerf of edge "A", the access kerf, onto the exposed grid flange.

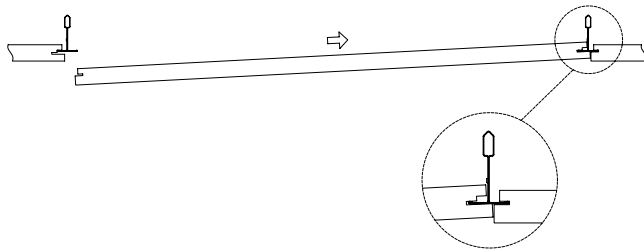

STEP 2: Raise the "B" edge of the panel, the registration kerf, into the grid opening until the kerf lines up with the grid flange.

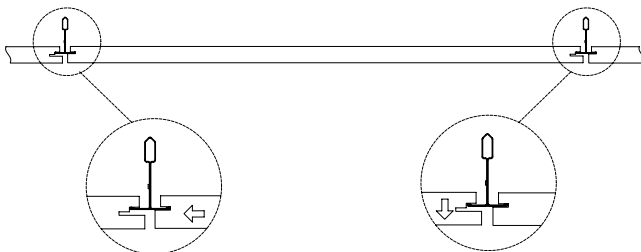

STEP 3: Slide the panel so that the registration kerf on edge "B" engages the grid flange. Ensure that the access kerf on edge "A" drops down into the correct position.

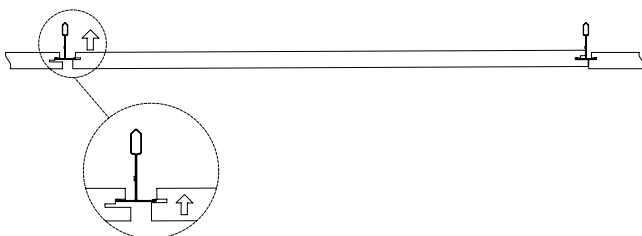

4.3. Orientation of Full Panels

Install all full-sized panels with the "A" edge facing in the same direction to provide access consistency. Align panels as you proceed to insure a uniform reveal width in both directions. Pay particular attention to this alignment process. Minor variations in placement can be difficult to see from the scaffold, but will become obvious when looking down long runs of panels.

4.4. Panel Removal

Press against the panel face to identify the edge that raises easily. This is the "A" edge. Move the A edge up and toward the web of the grid member until the "B" edge disengages and drops out of the ceiling plane.

5. PERIMETER DETAILS

5.1. General

Perimeters must be detailed as described in the following section.

5.2. Grid Resting on Perimeter Trim

The face of the suspension system components rests directly on the molding or trim flange. The border panels are cut to butt against the molding as shown here. The grain pattern on the panels dictates that they can be rotated 180°, but not 90°. Cutting borders will require two different techniques, one to use when the kerfs are perpendicular to the wall and another when they are parallel.

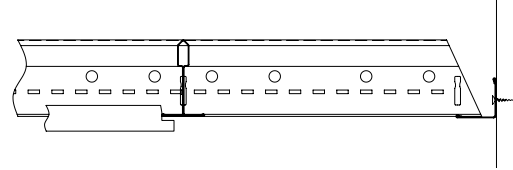

5.2.1. Kerfs Perpendicular to the Wall

Measure the size of the opening from the edge of the T-bar to the edge of the molding and add 3/8". Measure and mark the face side of the panel at both edges.

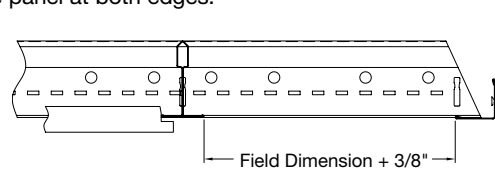

5.2.2. Cutting the Panel

Cut the panel using standard wood working tools and, where possible, a straight edge. A table saw is recommended for straight cuts and a band saw for curved cuts. In general, these practices will be typical of those employed in finish carpentry.

▲CAUTION! WOOD DUST. Sawing, sanding and machining wood products can produce dust. Airborne wood dust can cause respiratory, eye and skin irritation. The International Agency for Research on Cancer (IARC) has classified wood dust as a nasal carcinogen in humans.

Precautionary measures: If power tools are used, they should be equipped with a dust collector. If high dust levels are encountered, use an appropriate NIOSH-designed dust mask. Avoid dust contact with eyes and skin.

First Aid Measure in case of irritation:

Flush eyes or skin with water for at least 15 minutes.

5.2.3. Installing the Border Panel

Install these borders just like full size panels. Place the cut edge toward the wall and engage the "A" edge on the grid flange, rotate the "B" edge up into the grid opening and draw it back into place.

5.2.4. Kerfs Parallel to the Wall

Measure the panel as described in section A. Mark and cut the panel so as to retain the "A" edge.

5.2.5. Attach Border Clips

Apply WoodWorks Vector Border Clips to the cut edge of the panel as shown. Use one #8 x 9/16" screw in each clip. Clips are required within 6" of the edge and then at 1' centers.

Clips and screws for 2' x 2' panels are included in the carton. For all other panels sizes clips and screws are provided but shipped separately.

Install vector Safety clips in the same pattern as on full size panels.

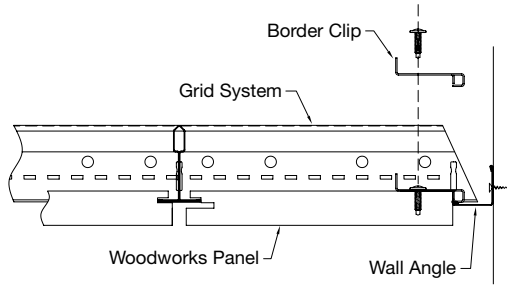

5.2.6. Installing the Panel

Engage the kerfed edge of the panel on the grid flange parallel to the wall. Rotate the cut edge up into the grid opening and draw the panel toward the wall until the border clips rest on the molding and the "A" edge drops into place.

5.2.7. Corner Panel Installation

Preparation of the corner panel will require the removal of two edges. Mark and cut the panel to retain a portion of the "A" edge. Support the Opposite side of the panel by installing WoodWorks Vector Border Clips as detailed above.

5.2.8. Treating Exposed Edges

Cut panel edges that are exposed to view will have to be treated to look like factory edges. Pre-finished peel and stick edge banding is available for this purpose. Cut edge must be clean and smooth before applying edge banding. Peel off the release paper (Edge banding and trimming tools are ordered directly from Armstrong through the Customer Focus center) and apply the edge banding using finger pressure or a small trim roller. Trim excess material with a sharp knife blade or with the edge trimmer available for order through Armstrong.

5.3. Ordering Edge Banding Material

Pre-finished pressure sensitive adhesive banding is available 15/16" wide and in 25' lengths.

6. ODD SIZE PANELS

6.1. General

Special size panels are available to accommodate less than full modules within the field of the ceiling. A second option would be to field cut these panels to the correct dimension. Examples of conditions that might require this procedure would be odd sized panels next to a linear air diffuser or 1' x 4' light fixture.

6.2. Measuring the Panel

Measure, mark and cut the panel 1/4" smaller than the "nominal" dimension required. For example, if the panel is to fit into a nominal 18" x 24" opening it would be cut 17-3/4" wide.

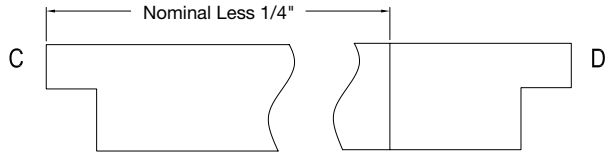

6.3. Re-cut the Edge Detail

Turn the panel over and re-cut the reverse tegular edge as dimensioned in the drawing below. Protect the face of the panel from damage.

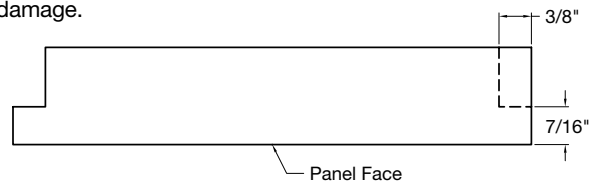

6.4. Treat the Cut Edge

Treat the re-manufactured edge as described in section 5.2.8. Install like a full size panel.

WoodWorks Vector Clip Arrangement

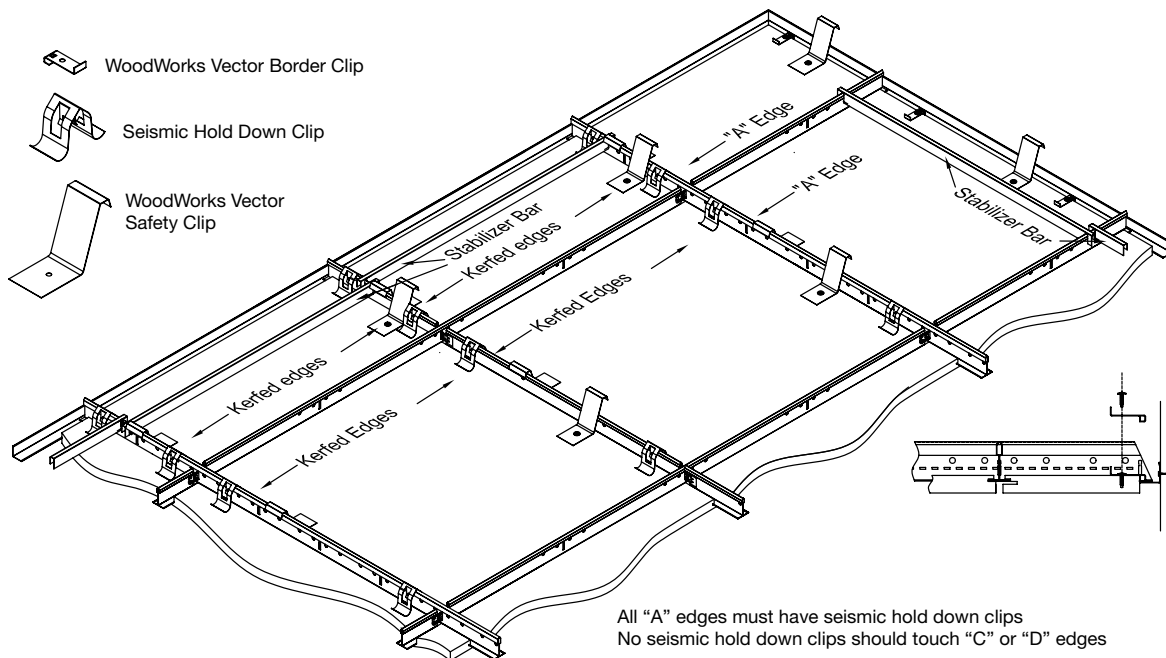

MORE INFORMATION

For more information, or for an Armstrong representative, call 1 877 ARMSTRONG

For complete technical information, detail drawings, CAD design assistance, installation information and many other technical services, call TechLine™ services at 1 877 ARMSTRONG or FAX 1 800 572 TECH.

For the latest product selection and specification data, visit armstrong.com/woodworks

U.S. Patents 5,417,025; 5,253,463; 5,355,646

All trademarks used herein are the property of AWI Licensing Company and/or its affiliates
© 2010 AWI Licensing Company • Printed in the United States of America

LA-295693-1010

