



Nailbase

Nailable Wall and Roof Insulation

INSTALLATION GUIDE

nailable rigid insulation
substrate for roofing applications

AVAILABLE IN
GX SERIES



ThermalStar

BY ATLAS EPS

DETAIL 1:
Rake Edge and Eave Sub-Fascia Installation

Notes

1. Insulation shall be trimmed from rake edge and eave to accommodate rake and eave sub-fascia. OSB shall be supported on rake edge and eave by wood sub-fascia.
2. To minimize the risks associated with air leakage, Atlas strongly recommends the use of multiple layers when the total desired or specified R-value requires an insulation thickness greater than, or equal to systems thicker than 2". To allow room for sub-fascia, EPS can be removed with the use of a hot knife or foam scoop.

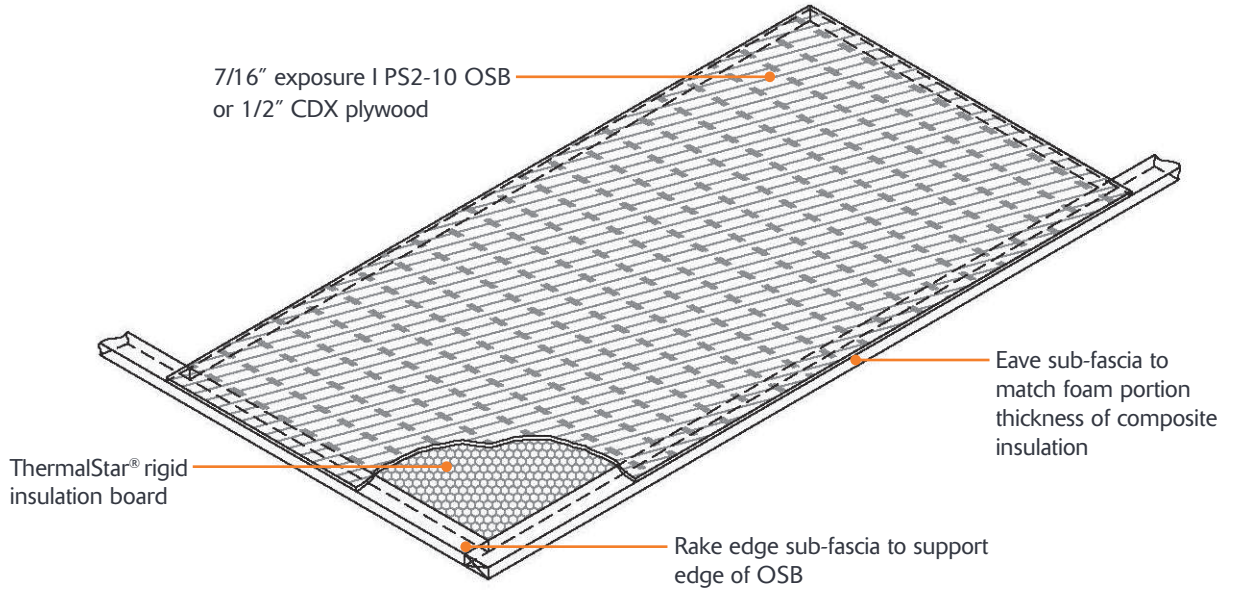

DETAIL 2:
Vapor/Air Retarder Installation

Notes

1. Atlas recommends that the designer carefully considers the need for a vapor/air retarder in order to limit the moisture and airflow into the roof system. Determining the need and location remains solely the responsibility of the architect, engineer or design professional. Refer to Building Science Corporation Design Guides for further details.
2. A suitable vapor retarder shall have a maximum permeance rating of 0.5 or less as determined by ASTM E96.
3. Follow vapor/air retarder manufacturer's installation instructions for seaming and perimeter edge terminations.
4. A two-layer insulation application significantly reduces moisture airflow into the roof system.

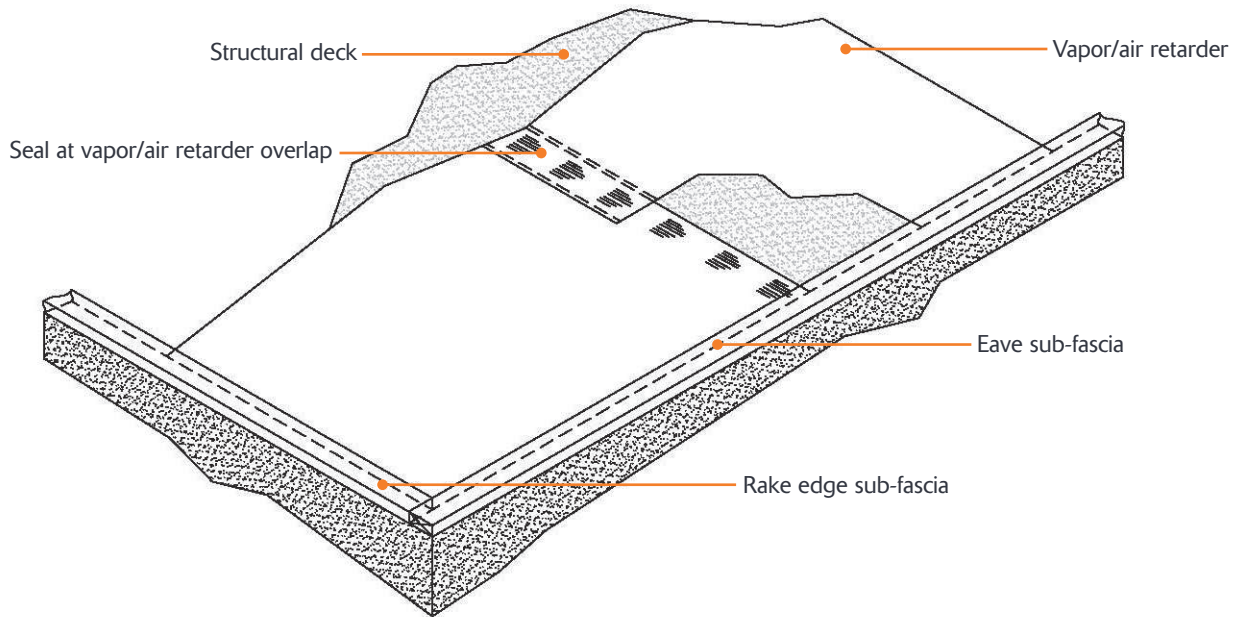

DETAIL 3: Recessed Edge Detail

Notes

1. To minimize the risks associated with air leakage, Atlas strongly recommends the use of multiple layers when the total desired or specified R-value requires an insulation thickness greater, or equal to systems thicker than 2".
2. To reduce air leakage, Atlas also recommends the use of expanding foam sealant to fill any gaps.

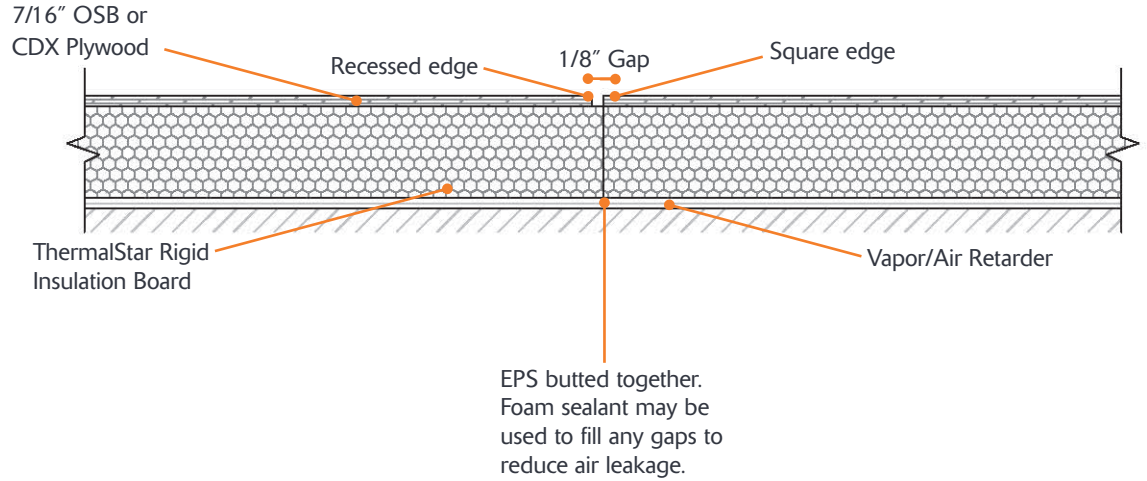

DETAIL 4: Typical Eave Detail

Notes

1. Refer to fastening requirements page for approved deck types. Fastener penetration minimums: *Wood Plank*: 1" penetration into deck; *Plywood*: 1/2" through deck; *Metal*: 3/4" through upper flange of the deck.
2. Atlas recommends that the designer carefully considers the need for a vapor/air retarder in order to limit the moisture and airflow into the roof system. Determining the need and location remains solely the responsibility of the architect, engineer or design professional.
3. For tile, slate or other heavy roof coverings, thicker OSB or plywood may be required. Consult roof covering manufacturer or design professional.

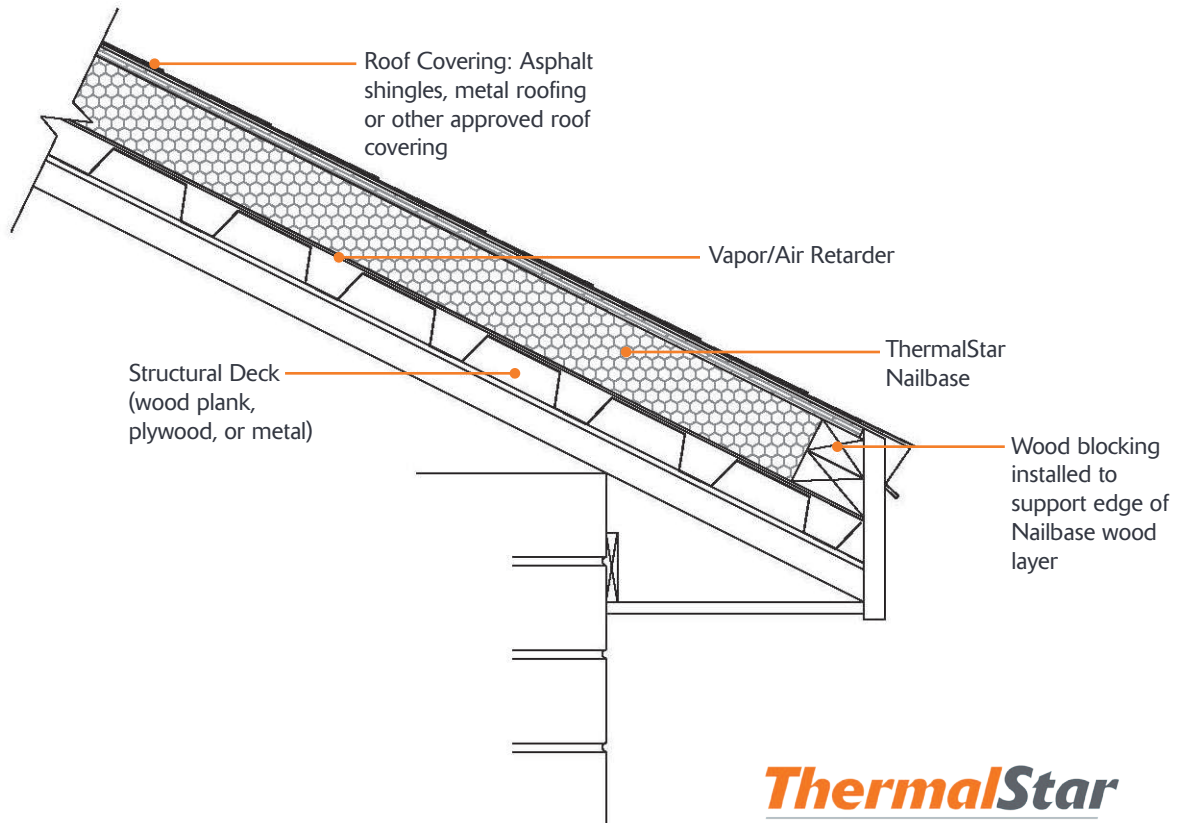

DETAIL 5:
2'-0" Staggered Installation of Nailbase over Base
(optional) Layer of Nailbase Accessory Sheets

Notes

1. To minimize the effects of thermal bridging, Atlas strongly recommends the use of multiple layers when the total desired or specified R-value requires an insulation thickness greater, or equal to on systems thicker than 2".
 2. If additional rigid insulation is needed beyond the Nailbase panel, ThermalStar Nailbase Accessory Sheets can be used to reach the desired R-value. The accessory sheets are available in following thicknesses:
 Standard 2" (R7)
 Standard 4" (R14.8)
 GX 2" (R8.3)
 GX 4" (R17.7)
- Other thicknesses available upon request.

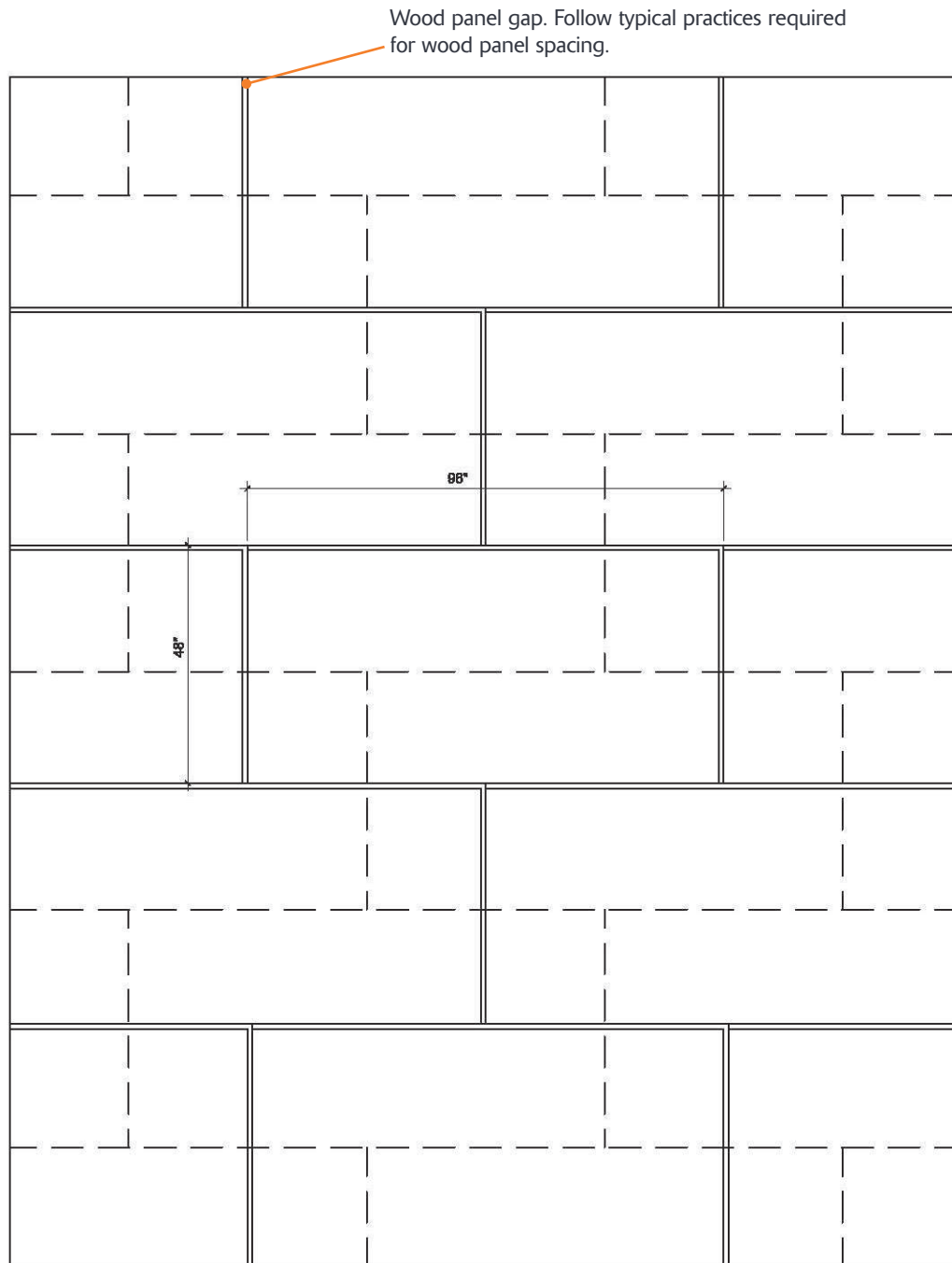

FASTENER SPECIFICATIONS for ThermalStar® Nailbase

APPLICATION: TRUFAST SIPLD Fasteners are specifically engineered for attaching nailbase panels to wood and steel framing, and are recommended for use with ThermalStar Nailbase.

PRODUCT FEATURES:

- Case hardened and tempered for easy installation and long term durability
- Large diameter, low profile pancake head for excellent pull through resistance, without the need for a washer, while still reducing “telegraphing” on shingles, metal panels and other roof surfaces.
- 6-lobe internal drive offers excellent bit engagement during installation, especially in high torque applications.

SIPLD FASTENER SPECIFICATIONS:

- Material: case hardened and tempered carbon steel
- Coating: Epoxy e-coat (black)
- Head Style/Driver: pancake head with T-30 internal drive

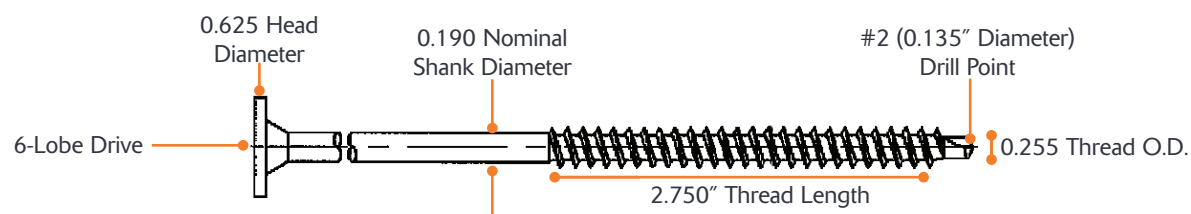

PERFORMANCE DATA:

Tensile Strength	Shear Strength	Head Pull-Thru Values	
		Structural Panel	SIP Panel
3,380 lbf.	2,900 lbf.	545 lbf.	630 lbf.

Lateral Load Resistance			
Main Member	Side Member	Load	
7/16" OSB	Nailbase	112 lbf.	
22 Ga. Corrugated Steel	Nailbase	411 lbf.	

Withdrawal Values in Steel (80 KSI min.)			
Type B Corrugated	22 Ga.	20 Ga.	18 Ga.
lbf.	510	645	920

Withdrawal Values in Wood							
Specific Gravity	0.67	0.55	0.5	0.46	0.43	0.36	0.31
lb/in	1,429	1,173	1,067	981	917	768	661



"Head-Pull-Thru," "Withdraw," and "Lateral Load" data reflect average ultimate values.

NOTE: All tests were conducted by an independent testing laboratory. Test results are offered only as a guide and are not guaranteed in any way.

FASTENING REQUIREMENTS for ThermalStar® Nailbase

Notes

1. These tables apply to roofs in areas of wind velocity not exceeding 110 mph, Exposure C, Importance Factor I = 1.15, and a maximum mean roof height of 60 ft. For overhangs, consult Atlas EPS Technical Department.
2. For use with TRUFAST SIPLD Fasteners only.
3. Refer to pages 8-10 for appropriate fastening patterns.
4. Roof perimeter area is defined as a band equal in width to 10% of the lesser roof plan dimension or 40% of the mean roof height, whichever is less (min. band width is 4ft). Perimeter area also includes corners.

APPROVED DECKS:

1. 18-22 ga. Steel Deck (3/4" through deck [top flange])
2. 1" min. wood plank and T&G (1" penetration into deck)
3. 19/32" minimum plywood (1/2" through deck)

FASTENER INSTALLATION:

1. The fasteners should be installed using an 1800-2500 RPM (max) screw gun with a hardened drive bit. Standard electric drill guns are not recommended for installation.
2. Metal decks are acceptable deck types provided they are between 18 ga. (max) and 22 ga. (min). Be sure to determine the gauge of the deck. For 16 ga. or heavier, consult with Atlas EPS Technical Department.

		Required Number of TRUFAST SIPLD Fasteners						
Roof Slopes	Roof Panel Location	3:12/6:12						
Snowload +10 PSF Dead Load- Total Load PSF		10-30	40	50	60	70	80	90
18-22 Ga. Steel	Field	15	15	15	15	15	15	20
	Perimeter	25	25	25	20	20	20	20
1" Wood	Field	15	15	15	15	15	15	15
	Perimeter	20	20	20	20	20	20	20
19/32" Plywood Minimum	Field	15	15	15	20	20	25	25
	Perimeter	25	25	25	25	25	25	25

		Required Number of TRUFAST SIPLD Fasteners						
Roof Slopes	Roof Panel Location	7:12/12:12						
Snowload +10 PSF Dead Load- Total Load PSF		10-30	40	50	60	70	80	90
18-22 Ga. Steel	Field	15	20	20	20	25	25	30
	Perimeter	20	20	25	25	25	25	30
1" Wood	Field	15	15	20	20	20	25	25
	Perimeter	15	20	20	20	20	25	25
19/32" Plywood Minimum	Field	15	25	25	25	30	35	40
	Perimeter	20	25	30	30	30	35	40

		Required Number of TRUFAST SIPLD Fasteners						
Roof Slopes	Roof Panel Location	14:12/24:12						
Snowload +10 PSF Dead Load- Total Load PSF		10-30	40	50	60	70	80	90
18-22 Ga. Steel	Field	20	25	30	30	35	35	40
	Perimeter	20	30	30	30	35	40	40
1" Wood	Field	15	20	25	25	30	30	35
	Perimeter	15	25	25	30	30	35	35
19/32" Plywood Minimum	Field	20	30	35	40	45	45	50
	Perimeter	20	35	35	40	45	45	50

FASTENING REQUIREMENTS for ThermalStar® Nailbase

Notes

1. These tables apply to roofs with no snow-load and wind velocity over 110 mph, but not exceeding 146 mph, in combination with 10 psi Dead Load, Exposure C, Importance Factor I = 1.15, and a maximum mean roof height of 60 ft. For overhangs, consult Atlas EPS Technical Department.
2. For use with TRUFAST SIPLD Fasteners only.
3. Refer to pages 8-10 for appropriate fastening patterns.
4. Roof perimeter area is defined as a band equal in width to 10% of the lesser roof plan dimension or 40% of the mean roof height, whichever is less (min. band width is 4ft). Perimeter area also includes corners.

APPROVED DECKS:

1. 18-22 ga. Steel Deck (3/4" through deck [top flange])
2. 1" min. wood plank and T&G (1" penetration into deck)
3. 19/32" minimum plywood (1/2" through deck)

FASTENER INSTALLATION:

1. The fasteners should be installed using an 1800-2500 RPM (max) screw gun with a hardened drive bit. Standard electric drill guns are not recommended for installation.
2. Metal decks are acceptable deck types provided they are between 18 ga. (max) and 22 ga. (min). Be sure to determine the gauge of the deck. For 16 ga. or heavier, consult with Atlas EPS Technical Department.

		Required Number of TRUFAST SIPLD Fasteners					
Roof Slopes	Roof Panel Location	3/12	4/12	5/12	6/12	7/12	8/12
18-22 Ga. Steel	Field	25	25	25	25	30	30
	Perimeter	45	45	45	45	35	35
1" Wood	Field	20	20	20	20	20	20
	Perimeter	35	35	35	35	25	25
19/32" Plywood Minimum	Field	20	20	20	20	25	25
	Perimeter	40	40	40	40	30	30

Roof Slopes	Roof Panel Location	9/12	10/12	11/12	12/12	14/12	15/12
18-22 Ga. Steel	Field	30	30	30	30	30	30
	Perimeter	35	35	35	35	35	35
1" Wood	Field	20	20	20	20	25	25
	Perimeter	25	25	25	25	25	25
19/32" Plywood Minimum	Field	25	25	25	25	25	25
	Perimeter	30	30	30	30	30	30

Roof Slopes	Roof Panel Location	16/12	17/12	18/12	20/12	22/12	24/12
18-22 Ga. Steel	Field	30	30	30	30	30	30
	Perimeter	35	35	35	35	35	35
1" Wood	Field	25	25	25	25	25	25
	Perimeter	25	25	25	25	25	25
19/32" Plywood Minimum	Field	25	25	25	25	25	25
	Perimeter	30	30	30	30	30	30

DETAILS 6-8
Standard Fastening Patterns for 4'x8' Sheets

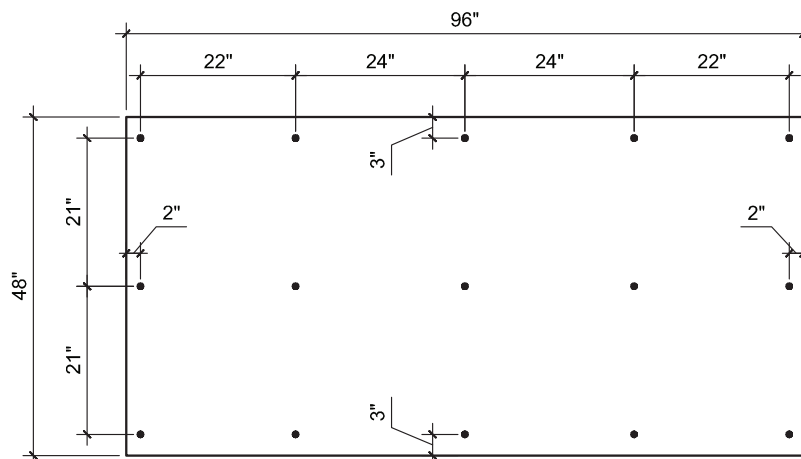

15 FASTENERS PER BD. (4'x8')

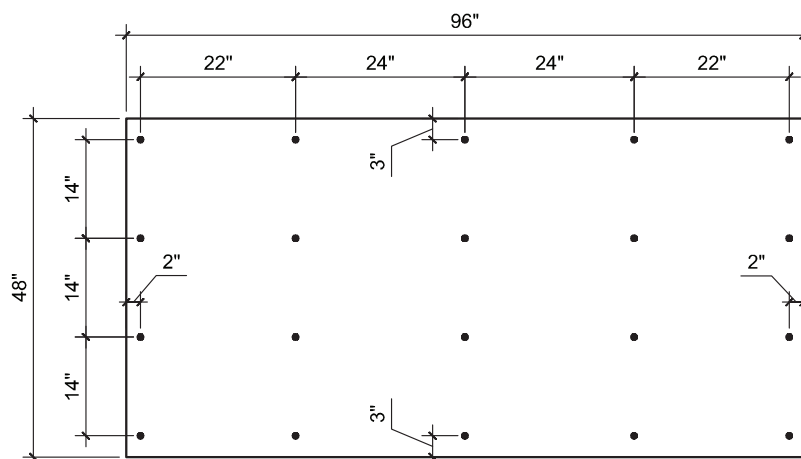

20 FASTENERS PER BD. (4'x8')

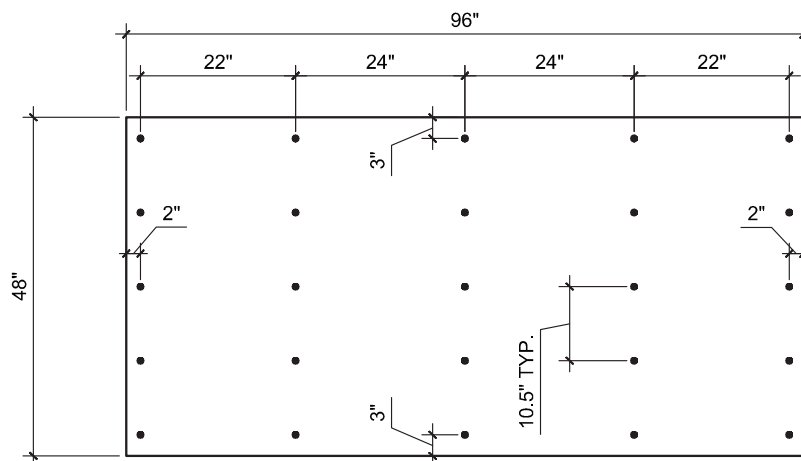

25 FASTENERS PER BD. (4'x8')

DETAILS 9-11

Standard Fastening Patterns for 4'x8' Sheets

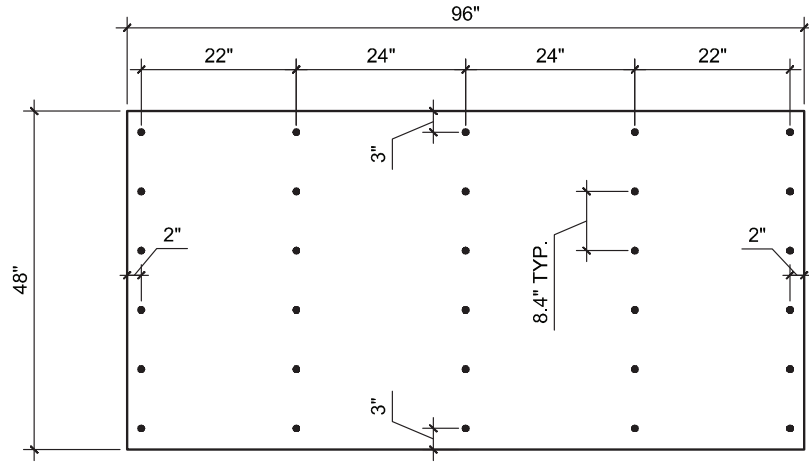

30 FASTENERS PER BD. (4'x8')

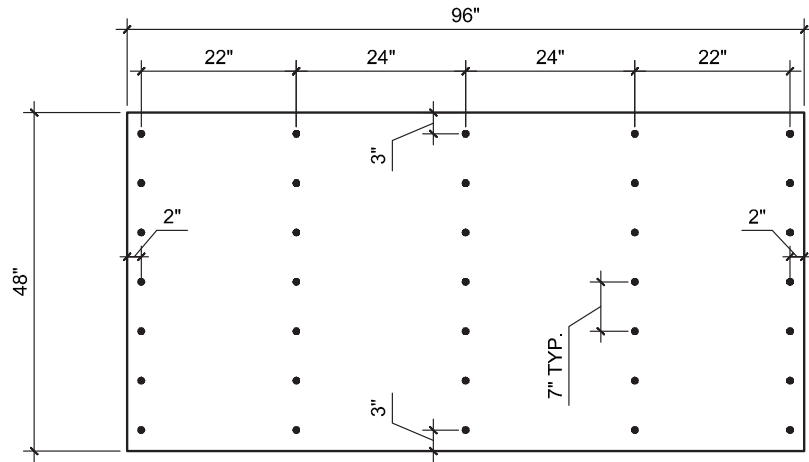

35 FASTENERS PER BD. (4'x8')

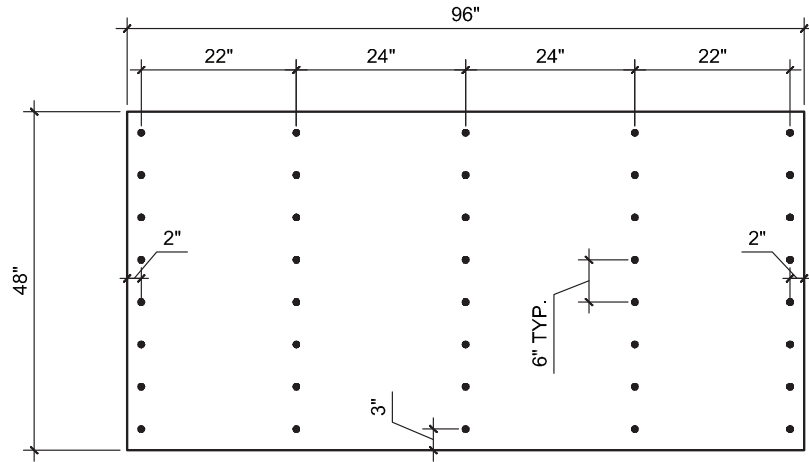

40 FASTENERS PER BD. (4'x8')

DETAILS 12-13
Standard Fastening Patterns for 4'x8' Sheets

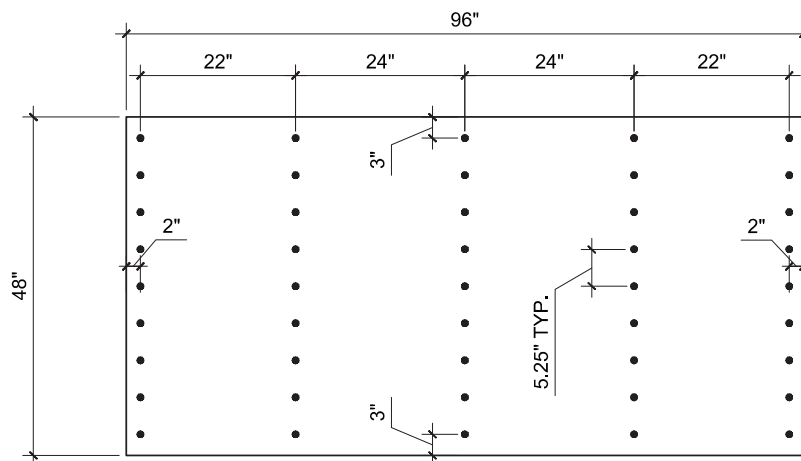

45 FASTENERS PER BD. (4'x8')

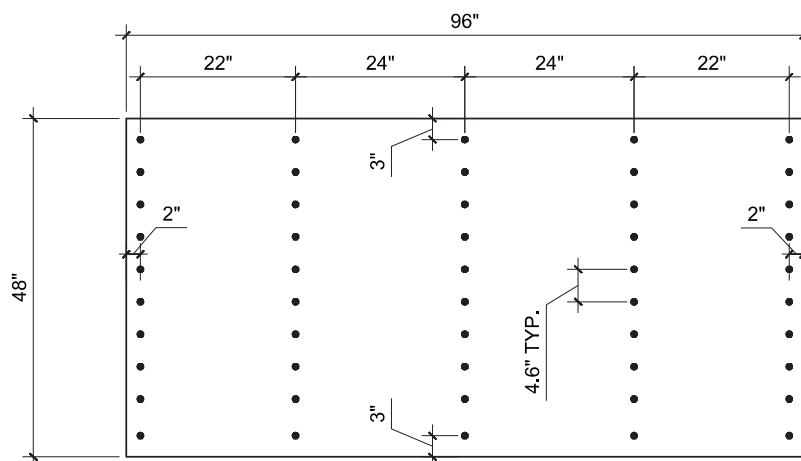

50 FASTENERS PER BD. (4'x8')