

# PRODUCT DATA SHEET

January 2004

## BIOSTOP® Composite Sheet

Classified Through-Penetration Firestop System Numbers:  
CAJ0089, CAJ4063, CAJ8122



### 1. Product Description

BIOSTOP® Composite Sheet is a rigid fire resistive panel used to seal penetrations and restore the fire rating to floor/ceilings or walls in which a large opening has been made for the passage of penetrating items. It is made of a reinforced, highly intumescent material which is bonded on one side to a galvanized steel sheet. In addition to sealing penetrations through large openings, BIOSTOP® Composite Sheet is also used for shielding cable trays, conduit, and vital process equipment from radiant heat, flame spread and smoke. The BIOSTOP® Composite Sheet functions as an effective intermediate fire-break within horizontal and vertical cable tray runs and is excellent for both new and retrofit construction. When exposed to a fire the material forms a refractory char that retards heat transmission and tightly seals penetrations against flame spread, smoke and toxic fumes. The nominal 0.2 inch (5 mm) thick composite sheet provides up to a 3 hour fire rating. It is lightweight and can be easily installed with common trade tools.

Use BIOSTOP® Composite Sheet for various applications:

Large blank openings  
Cable trays  
Steel pipe, EMT, Cable Bundles  
Concrete floors  
Concrete walls

### BIOSTOP® Composite Sheet Features:

- Intumesces (expands with heat) to form a refractory char that tightly seals penetrations against flame spread, smoke and toxic fumes.
- Easy to install using common trade tools.
- Lightweight ... easy to handle, cut and form to desired shape.
- Easy to fasten... bolt punch or drill through. Use self-tapping screws or anchor bolts.
- Thermally conductive: allows unwanted heat build-up to escape.
- Non-flame supporting.
- UL Classified.
- Cost effective, high performance versus installed cost.
- No mixing or damming... is clean to install.
- Versatile: can be cut to fit irregular shapes.
- Re-enterable.
- Normal disposal procedures.

### 2. Physical Properties

Sheet Size:	36" x 36"
Total Thickness:	0.2 inch
Nominal Weight:	1.6 lb/ft <sup>2</sup>
Cure Time:	No
Skin Over Time:	No
Freeze-Thaw:	Excellent
VOC:	None
Solvent:	None

### 3. Applications

BIOSTOP® Composite Sheet is used to seal penetrations through fire-rated walls and floors and for cable trays, cable, piping and large blanks. It provides a fire resistive smoke seal for any shape opening in concrete block or slabs for up to 3 hours - UL Classified.

Use BIOSTOP® Composite Sheet to shield cable trays, conduit, panels, valves and vital heat-sensitive process equipment. The product is effective in protecting cable drop-outs, junction boxes and cabinets, as well as providing an intermediate firestop in horizontal and vertical cable tray runs.

### 4. Installation Data

Install BIOSTOP® Composite Sheet using standard sheet metal tools.

Typical blank opening installation

#### Step 1

Cut the BIOSTOP® Composite Sheet to overlap the opening by a minimum of 2 inches on all sides.

#### Step 2

Secure the sheet to the opening using 1/4" x 1 1/4" steel masonry fasteners with steel washers. Place along the perimeter and space a maximum 6 inches apart. Install the Composite Sheet with its galvanized steel side exposed (facing outward).

**Step 3**

Seal the overlap onto the floor/wall using BIOSTOP® Putty or BIOSTOP® Putty Pads.

**5. Testing Data**

For specific test criteria, refer to the UL's Fire Resistance Directory or call RectorSeal.

BIOSTOP® Composite Sheet was tested at positive pressure with a minimum 0.01 (2.5 Pa) inch water and in accordance with ASTM E814 (UL1479).

**6. Storage and Handling**

BIOSTOP® Composite Sheet should be stored in a clean, dry place.

**7. Availability**

BIOSTOP® Composite Sheet comes in a 36 inch by 36 inch square sheet. They are available through RectorSeal® distributors both domestically and internationally.

**8. Limitations**

BIOSTOP® Composite Sheet is not designed to be used in the areas under continuous immersion or in areas which would be continuously wet. BIOSTOP® Composite Sheets should not be used against a hot uninsulated surface above 300°F.

**9. Cautions**

**FOR CHEMICAL EMERGENCY, SPILL, LEAK, FIRE, EXPOSURE OR ACCIDENT, CALL**

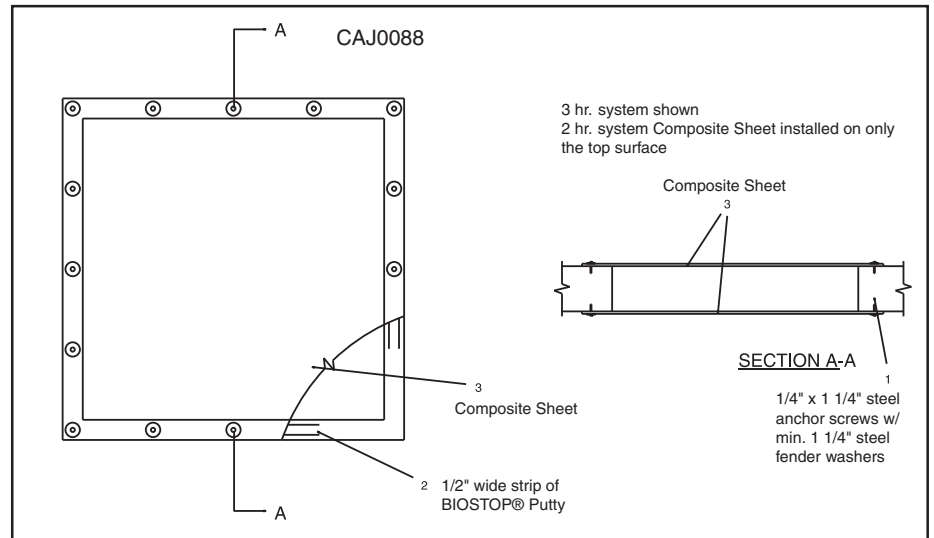

CHEMTREC-DAY OR NIGHT 1-800-424-9300.

**PRECAUTIONS:** Do not take internally. May be harmful if swallowed. **FIRST AID:** For any overexposure, get immediate medical attention after first aid is given. **Eyes-** Flush 15 minutes with clean water. **Skin-**Wash with soap and water. **Ingestion-**Only if conscious, give large amounts of water and INDUCE VOMITING. **STORAGE AND HANDLING:** Store away from heat sources. **KEEP OUT OF REACH OF CHILDREN.**

For additional information, refer to Material Safety Data Sheet.

**For additional technical service, call: 713-263-8001 or 1-800-231-3345 fax: 713-263-7577 or 1-800-441-0051**

RECTORSEAL  
2601 SPENWICK DRIVE HOUSTON, TEXAS 77055  
WWW.RECTORSEAL.COM

**9. LIMITED WARRANTY**

RectorSeal makes the Limited Express Warranty that when the instructions for storage and handling of our products are followed we warrant our products to be free from defects. THIS LIMITED EXPRESS WARRANTY IS EXPRESSLY IN LIEU OF ANY OTHER EXPRESS OR IMPLIED WARRANTIES, INCLUDING ANY IMPLIED WARRANTY OF MERCHANTABILITY OR FITNESS FOR A PARTICULAR PURPOSE, AND OF ANY OTHER OBLIGATION ON THE PART OF RECTORSEAL. The sole remedy for breach of the Limited Express Warranty shall be the refund of the purchase price. All other liability is negated and disclaimed, and RectorSeal shall not be liable for incidental or consequential damages.

Suggestions and recommendations covering the use of our products are based on our past experience and laboratory findings. However, as we have no control as to the methods and conditions of application, we only assume responsibility for the uniformity of our products within manufacturing tolerances.