

18. Roof Drain with Lead Flashing

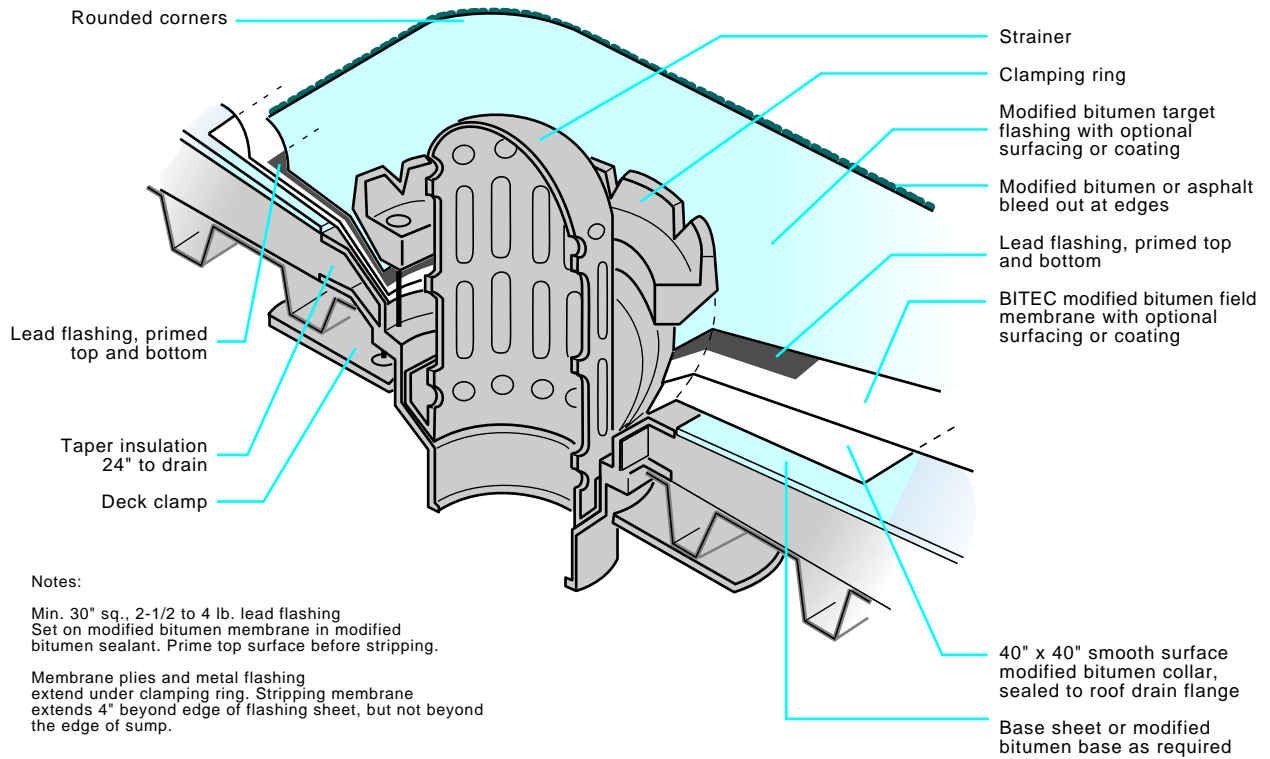

19. Sheet Metal Pan Roof Drain

