

APPLICATIONS FOR HWD-15® HARDWOOD FLOOR UNDERLAYMENT

THE DETAILS SHOWN HERE REFER TO GENERALLY ACCEPTED INSTALLATION GUIDELINES

HWD-15 is a moisture and vapor retarder, reducing or preventing moisture migration. By allowing wood flooring time to adjust gradually to changes in moisture conditions, you protect against moisture related problems in wood floors. **HWD-15** also aids installation by providing a smooth surface for positioning flooring. It covers residual dust on sub-floors after sweeping, and reduces noise such as wood-on-wood squeaks. Cleaner-handling than roofing felt, **HWD-15** Hardwood Floor Underlayment minimizes asphalt rub-off during installation.

HWD-15 has a VOC rating of 0, and is an industry accepted vapor retarder meeting wood flooring installation guidelines and 2006 IRC requirements. As a permeable vapor retarder, **HWD-15** is not likely to trap moisture on top of or within the sub-floor like an impermeable poly film or poly-coated material does. Although **HWD-15** slows moisture migration, it is not a moisture barrier.

This guide provides examples of typical hardwood flooring installations employing **HWD-15**. The descriptions are brief and do not cover all circumstances that an installer may encounter during installation. It is the responsibility of the installer to obtain, read and follow the flooring manufacturer's complete instructions, industry guidelines and local building codes.

BEFORE YOU BEGIN

JOB SITE CONDITIONS

Evaluate jobsite before flooring is delivered and installation begins.

- Site drainage must direct water away from foundation.
- Building must be completely enclosed.
- All other interior work should be completed.
- Interior environmental conditions must be at occupied levels.
- Test flooring for moisture content and acclimate per manufacturer's recommendation.
- Basements and crawl spaces must be dry.

INSTALLATION ENVIRONMENT AND SUB-FLOOR PREPARATION

Regardless of the sub-floor the hardwood flooring is installed over, several elements are critical to a quality installation. First, any wood (plywood or screeds) that the flooring is attached to should have a moisture content within the range for the specific area. Second, the flooring material needs to be on the job site, unbundled, and allowed to acclimate to the conditioned interior space prior to installation.

WOOD SUB-FLOOR PREPARATION

- All surface debris and protrusions must be removed.
- Check sub-floor for squeaks and repair.
- Sweep and vacuum prior to filling or repairing voids.
- Fill voids and level high spots, sweep again.
- Check sub-floors for moisture content by an appropriate method per flooring manufacturer's recommendation.

WOOD SUB-FLOORS - NAILED

Always read and follow the floor manufacturer's installation instructions. Cut **HWD-15** to length and position over wood sub-floor as needed for proper coverage. Overlap edge seams a minimum of 4 inches. Once **HWD-15** is installed, staple in place and snap chalk lines to desired layout. Never use an impermeable vapor retarder, such as poly film or poly-coated material, over a wood sub-floor. Red rosin and common building paper, which is not asphalt saturated, are not vapor retarders and should never be used in place of a vapor retarder.

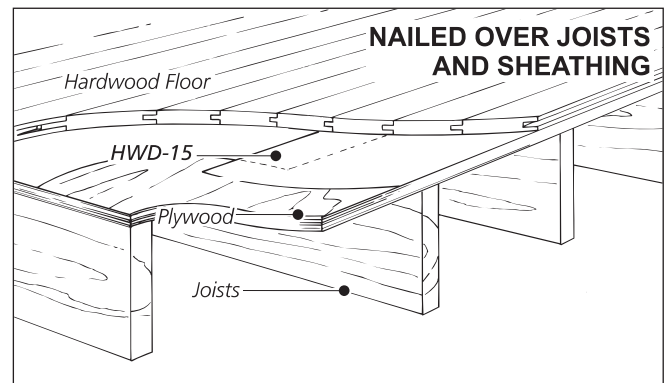

FOR WOOD SUB-FLOORS ABOVE CRAWL SPACE

- Crawl space must be a minimum 18" from ground to underside of joists and properly cross vented as required by local code.
- Crawl space earth must be covered 100% by a vapor retarder with a perm rating of ≤ 0.15 , such as **Moistop Ultra** or minimum 6 mil Fortifiber Polyethylene Film. We strongly recommend a superior, puncture resistant and more durable membrane meeting ASTM D1745, such as Fortifiber's **Moistop Ultra** 6, 10 or 15.
- Overlap crawl space vapor barrier a minimum 6" and tape as required by manufacturer.
- Vapor barrier must extend a minimum 6" up stem wall and above any visible signs of wicking, be attached and sealed to stem wall.

FOR ON-GRADE OR BELOW-GRADE CONCRETE SUB-FLOORS

- An underslab vapor retarder meeting ASTM D1745 has been properly installed, such as **Moistop Ultra** family of products. Consult local building codes for minimum requirements.
- The slab is thoroughly dry before installation of wood flooring. Generally slabs must be 30 days old. Test slab for moisture following flooring manufacturer's recommendation.

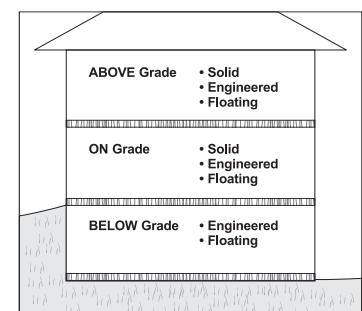

Continued on reverse...

*The **Moistop Ultra**® family of underslab vapor retarders are critical for Wood and Tile floors placed on concrete slabs.

APPLICATIONS FOR HWD-15® HARDWOOD FLOOR UNDERLAYMENT

...continued from front

- If excessive moisture is present (>3 lbs. in the calcium chloride test) install a vapor retarder with rating of ≤ 0.15 perms such as minimum 6 mil Fortifiber Polyethylene Film or **Moistop Ultra**.
- Below-grade, only use flooring recommend by the flooring manufacturer for below-grade installations

CONCRETE SUB-FLOORS - FLOATED & NAILED

- Follow wood floor manufacturer's recommendation or NWFA guidelines for placement of plywood.
- Cut and install **HWD-15** over plywood as above
- Follow wood floor manufacturer's instructions or NWFA guidelines for wood flooring installation.

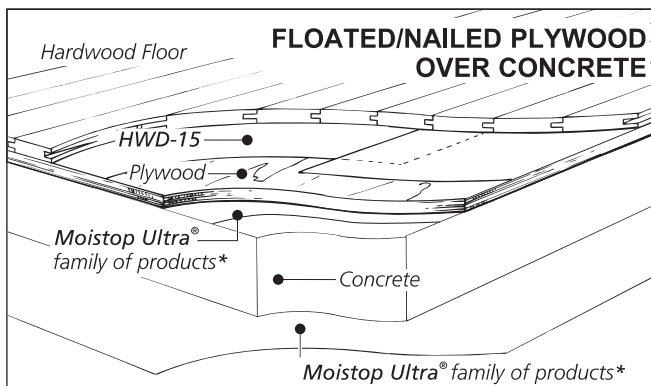

CONCRETE SUB-FLOORS - SCREED SYSTEM

For on-grade slabs,

- Install flat, dry, preservative treated 2x4s, cut 18-24" long, laid flat at right angles to finished floor, spaced 12" o. c. and embed in adhesive.
- Then lay a vapor retarder with a perm rating of ≤ 0.15 over screeds, such as a minimum 6 mil poly film or Fortifiber's **Moistop Ultra**
- Install plywood and cover with **HWD-15** as above.
- Follow wood floor manufacturer's instructions or NWFA guidelines for wood flooring installation.

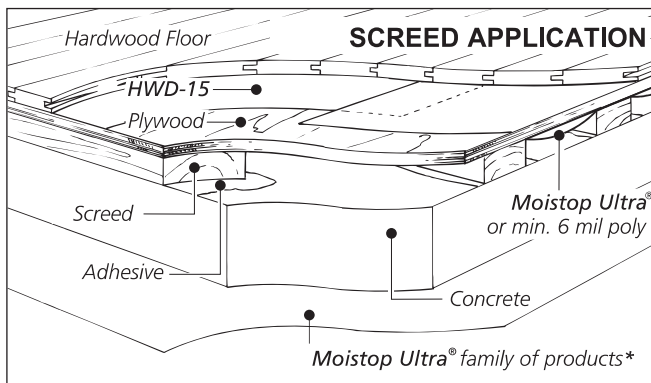

LIMITATIONS: HWD-15 Moisture Vapor Retarder Paper is not a waterproof membrane and should not be used in waterproofing assemblies where a waterproof membrane is specified. Do not use in high moisture or steam areas. Properly prepared walls, sub-floors, jobsite conditions and proper installation of flooring are the responsibility of the installer. HWD-15 does not guarantee to eliminate moisture related problems; it serves to reduce the potential for, and extent of, moisture problems when properly installed. Not recommended over radiant heat systems, which may result in asphalt odor.

NOTE: In applications where duplex type, 30/30/30, asphalt laminated paper, meeting Fed Spec. UU-B-790a, Type 1, Grade B, Style 1a, or UBC Standard 14-1, is specified, use Fortifiber's **Aquabar "B" Barrier Paper**. In applications where duplex type reinforced asphalt paper, meeting ASTM C-171, is specified use Fortifiber's **Orange Label Sisalkraft**.

INSTALLING WOOD FLOORING

Wood flooring should be installed in accordance with wood flooring manufacturer's instructions or architect/specifier and all local building codes. For more detailed installation instructions for wood floors consult the manual: **Hardwood Flooring Installation Guidelines** available from:

National Wood Flooring Association
www.woodfloors.org 1-636-391-5161

Or *Installing Hardwood Flooring* available from:

National Oak Flooring Manufacturers Association
www.nofma.org 1-901-526-5016

FINISHED FLOORING PROTECTION

After installation, if you choose to protect the floor, cover the floor completely. Prior to covering, be sure finish is fully cured following finish manufacturer's recommendation. Use Fortifiber's **Seekure**, a durable, reinforced, protection paper, with a perm rating >1 to avoid trapping moisture, and a water holdout rating of >60 minutes. Tape the **Seekure** protection paper to base or shoe mold using a low adhesion tape, such as 3M "orange core". Avoid taping to finished floor. As needed for complete coverage, overlap adjoining rolls a minimum 6" and tape joints.

Fortifiber provides you with a full line of products that will help you protect your flooring investments:

- **Seekure® Floor Protection Paper**
- **Aquabar "B" Barrier Paper**
- **Orange Label Sisalkraft®**
- **Moistop Ultra® family of products**

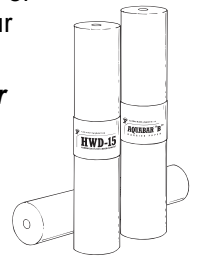

Call 1-800-773-4777 Nationwide for
Technical Assistance or visit our website
at www.fortifiber.com



**Fortifiber Building
Systems Group®**

Protecting Your World from the Elements®

NATIONAL SALES OFFICE Reno, NV

(1/7/08)