

MasterFlow® Green Machine™ Dual Powered Roof Vent

Application Instructions
Updated: 2/10



***Quality You Can Trust Since 1886...
From North America's Largest
Roofing Manufacturer™***

Safety Considerations and Warnings

1. Use appropriate safety glasses, gloves, hard hats, restraints, and other equipment to avoid injury.
2. Wear durable work gloves while handling the unit during installation. This product has sharp edges that can cause injury.
3. Observe all applicable building codes in your area.
4. Do not damage electrical wiring or other hidden utilities when cutting or drilling.
5. Make sure the fan blade is on tight and ensure the set screw is securely tightened.
6. Use this unit only in the manner intended by GAF-Elk. If you have any questions, please contact Master Flow® Technical Service at 1-800-211-9612.
7. Ducted fans must always be vented to the outdoors.
8. **WARNING... DUAL POWER SOURCE! TO REDUCE THE RISK OF FIRE, ELECTRIC SHOCK, OR INJURY TO PERSONS, OBSERVE THE FOLLOWING:**
 - a) Installation work and electrical wiring should be performed by qualified persons in accordance with applicable building codes and standards, including codes for fire ratings.
 - b) Before servicing or cleaning unit:
 - Switch power off at the service panel and take all steps necessary to prevent power from being switched on accidentally. If the service panel cannot be locked, securely fasten a prominent warning device, such as a tag, to the service panel.
 - Disconnect power leads from solar panel to prevent accidental operation.
9. This fan should be connected to a circuit with minimum 14 gauge wiring that has at least 3 amperes of available capacity. If you can not confirm that there is sufficient electrical capacity on an existing circuit, install a separate dedicated circuit. DO NOT use an extension cord to operate. All electrical wiring should comply with National Electrical Code and all other local codes. Contact a qualified electrician if you are not comfortable or familiar with electrical codes and/or installations.

10. **FOR HOMES WITH A GAS OR OIL FURNACE LOCATED IN THE ATTIC:** The ventilator MUST be wired with a switch or other interlocking device to prevent the furnace and ventilator from operating at the same time during the heating cycle. The switch or other interlocking device MUST disconnect the vent unit from both the electrical circuit power and the solar panel. We recommend that the switch (not provided) be installed by a qualified person in accordance with all applicable codes and standards.

CAUTION: FOR GENERAL VENTILATING USE ONLY.

THIS FAN HAS AN UNGUARDED IMPELLER. DO NOT USE IN LOCATIONS READILY ACCESSIBLE TO PEOPLE OR ANIMALS. DO NOT USE TO EXHAUST HAZARDOUS OR EXPLOSIVE MATERIALS OR VAPORS.

Important: Your solar panel configuration may differ from the one shown in the illustrations. The performance of all configurations is the same.

Tools Required

- Drill
- 1/8" (.3cm) Drill Bit
- Extension Cord
- Utility Knife
- Power Saber or Jig Saw and/or Hand Saw
- Safety Eyewear
- Galvanized Roofing Nails
- Caulking Gun
- Gloves
- Ladder
- Claw Hammer
- Screwdriver
- Pencil or Marker
- Silicone
- Pliers
- Roofing Cement
- Nut Driver



*Quality You Can Trust Since 1886...
From North America's Largest
Roofing Manufacturer™*

1. Determine Location... Place vent as close to the peak of the roof as possible but below the ridge line. Be sure the unit faces to the south for optimal power. Make sure the location is not shaded by trees or other nearby structures during the day (Figure 1a). Measure from the peak of the roof to the midpoint of the solar power vent (Figure 1b). Transfer this measurement into the attic and mark the location inside the attic, centered between two rafters, and drill a hole (Figure 1c). Put an object, such as a pencil or nail, through the hole to mark it on the outside. **Note:** Single units should be centered. If multiple units are used, space evenly over the length of the ridge.

CAUTION: Be sure to mount the vent unit on the outside of the roof deck (motor down) above unoccupied attic space.

2. Mark Opening... Cut out the 15" (38.1cm) template located on the French language panel of the Dual Power Roof Exhaust Vent carton. Place center of template over hole marked in roof, in step one. Use correctly positioned template to mark a circle. For rafters 24" (61cm) on center, mark the cut – out as shown in (Figure 2a). For rafters 16" (40.6cm) on center, proceed with marking as shown (Figure 2b).

3. Cut Out Opening And Test Position... Roll back and separate all shingles 7" (17.8cm) from the top and sides of the cut-out area. Be sure that all roofing nails have been removed. Using a saber saw, jig saw or hand saw, cut and remove all roof shingles and deck inside the 15" (38.1cm) diameter circle (Figure 3a). Do not cut any rafters. Test the final position by inserting the top half of the unit flashing under the rolled shingles. Trim shingles as necessary (Figure 3b).

4. Secure And Seal Unit... Remove the unit from the test position and liberally apply roof cement to the bottom side of the flashing. Align the unit and slide it under the shingle corners. Be sure that the arrow marked in the flashing points up to the roof peak. Secure the unit into place with galvanized roofing nails at all four corners and approximately every 4" (10.2cm) along the sides of the flashing (Figure 4). Finish by using roof cement to seal all flashing and shingle edges, as well as nail heads and stack vertical seam. Press all raised shingle edges back into position. **Warning:** Using excess roof cement may cause blistering in the roofing shingles.

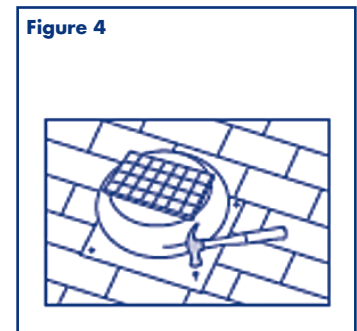
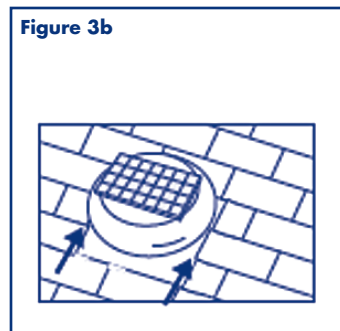
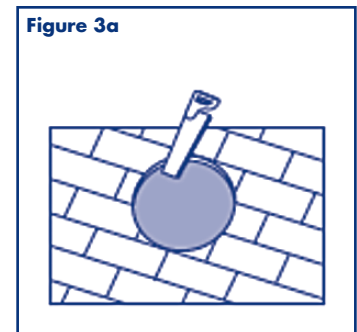
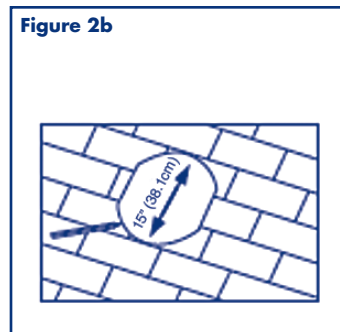
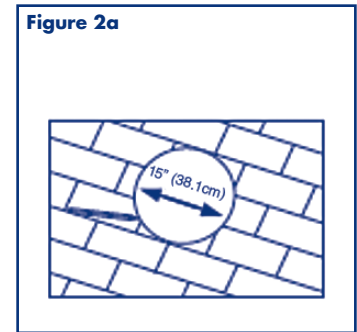
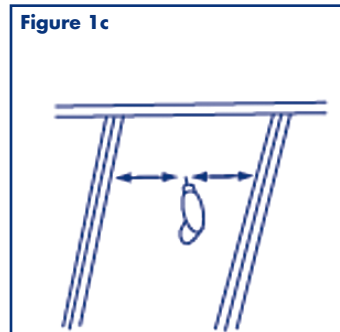
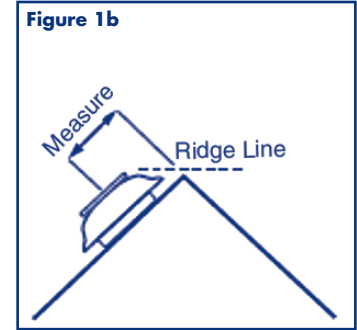
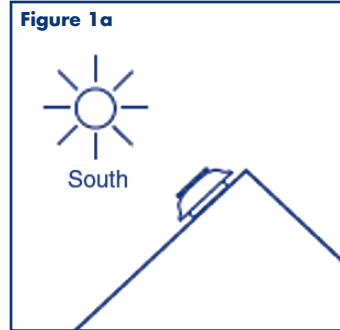

5. Mount Solar Panel... (Use only if mounting Solar panel on roof deck) Remove the included solar panel mounting kit from the carton. The kit contains deck screws, (2) 1/4"-20 bolts, (2) nylock nuts, and (2) "L"-shaped wings.

A. Mark "L"-shaped brackets & top rail mounting holes... Attach the "L"-shaped wings loosely to the short slots on side of panel mounting rail (Figure 5a). Place unit on shingles so that fastener holes in L-shaped wings and top of rails are at least 1.5" (3.8 cm) away from exposed shingle edges to avoid possible weather infiltration. Use a grease pencil or chalk to trace the outline of the "L"-shaped wings on the shingles and also to mark both top rail mounting holes.

B. Attach "L"-shaped brackets to roof... Once you have marked the "L"-shaped wings and top rail mounting holes, remove the "L"-shaped wings from the solar panel frame and lay the panel aside. At the locations previously traced, carefully pry the shingles and slide each "L" shaped wing under the shingles. Align both wings with the visible portion of your traced outline. While lifting the shingles, attach both "L" wings to the roof deck with a provided deck screw (Figure 5b). Press the shingle back down into place. Apply roofing cement under the shingles to seal them to the roof.

C. Attach top rail bracket... Carefully lift up the shingles where the top rail mounting holes were previously marked. Now, align the panel frame between the installed "L"-shaped wings. Center the slots in the rails with the mounting holes on the wings. Slide the top rails under the raised shingles and attach each rail to the roof deck with a provided deck screw (Figure 5c). Press the shingles back down into place. **Note:** You may have to tilt the panel to access the top rail mounting holes. **Note:** Apply roofing cement under the shingles to seal them to the roof. Finally, re-attach the "L"-shaped wings to the rails with the provided bolts and nuts and fasten them securely (Figure 5d).

CAUTION: THIS FAN AUTOMATICALLY STARTS WHENEVER THE SOLAR PANEL IS EXPOSED TO A LIGHT SOURCE, OR ACTIVATED BY AUTOMATIC THERMOSTAT FROM HOUSE POWER. ALWAYS EXERCISE CAUTION WHEN IN THE VICINITY OF THE FAN.

6. Adjust Solar Panel... When adjusting the solar panel, be sure to tilt or rotate the panel to maximize direct exposure to the sun. To tilt the solar panel, loosen the two screw/nuts (Figure 6a) on the rail mount/linkage connection. Then raise the panel to the desired location and re-tighten (Figure 6b). To rotate the solar panel (for hood mount installations only), loosen four wingnuts, rotate panel to desired position and tighten securely.

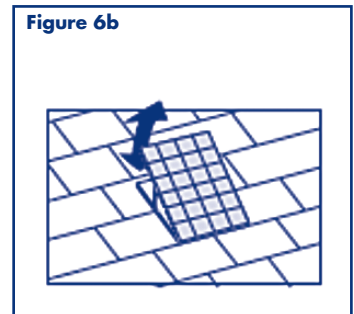
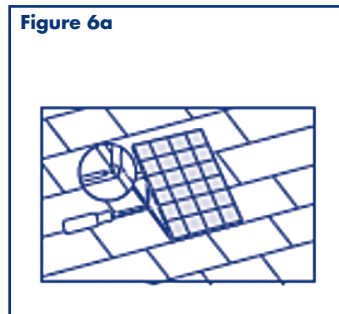
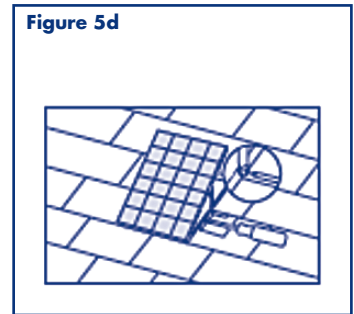
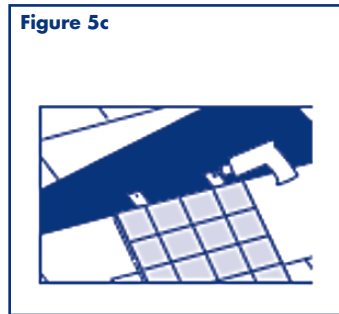
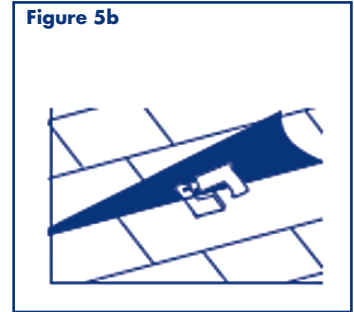
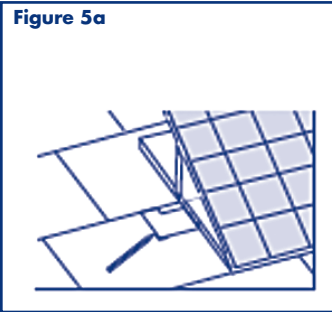

Note: The optimum angle can be calculated by using the approximate latitude of the house plus 20 degrees. The solar panel should face south, when possible.

Note: In the unlikely event that parts and/or accessories are missing, or this product does not operate correctly, contact Master Flow® Technical Services. Do **NOT** return to retailers or distributors.

7. Mount Control Module... Remove the Control Module from inner carton. Fasten it to the edge of stud or rafter adjacent the fan (motor leads are 24" in length) with wood screws (not included) through pre-punched mounting tabs on side of Control Module.

8. Wiring...

- Remove Control Module cover by gently prying cover off of retention tabs on sides. **CAUTION:** Control board has sensitive electronic components.
- Install romex type connector (not included) in 1/2" knockout and insert house power cable
- Connect house power wires as shown (Figure 7).
- Adjust thermostat as desired from 60°F to 120°F (105°F recommended, factory setting is 60°F)
- Connect the male solar plug to female plug on Control Module, and connect the male plug on Control Module to the female motor plug
- Each Dual Power Roof Exhaust Vent unit must have its own Control Module

9. OPERATION...

The Dual Power Roof Exhaust Vent will operate when sufficient solar light is on the solar panel regardless of thermostat setting or house power connection for efficient exhaust of attic heat and humidity year round.

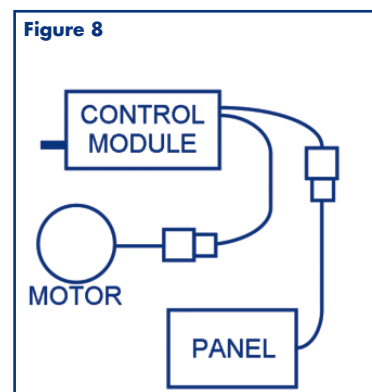
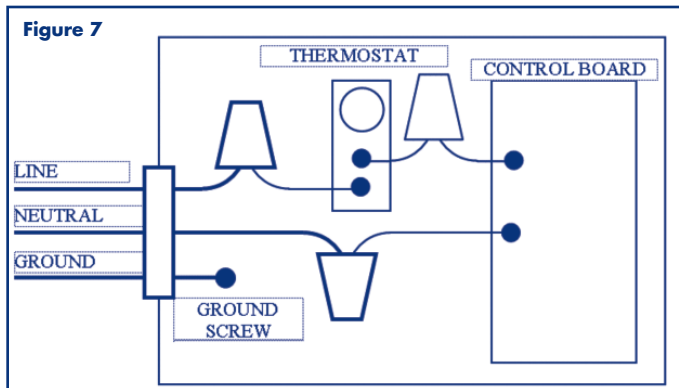

Visit www.gaf.com

Quality You Can Trust Since 1886...From North America's Largest Roofing Manufacturer™