

SCS9000 SilPruf* NB

non-staining silicone weatherproofing sealant

Product Description

GE SCS9000 SilPruf* NB is a 100% silicone polymer sealant formulated to reduce or eliminate dirt pickup, surface streaking, and substrate staining. SCS9000 is a premium one-component, medium-modulus, neutral cure silicone sealant useful on a wide variety of materials in new or remedial applications. Supplied as a paste, SCS9000 produces a durable silicone rubber joint sealant upon cure.

Typical Performance Properties

Performance

- **Silicone Durability** - cured silicone rubber exhibits excellent long term resistance to natural weathering including: extreme temperatures, ultraviolet radiation, rain and snow, with negligible change in elasticity.
- **Adhesion** - primerless adhesion to many substrates and finishes. May be considered a candidate for use with numerous construction-related materials, including: glass, polycarbonate, vinyl, numerous plastics, treated and untreated wood, fluoropolymer and powder coated paints, conversion-coated and anodized aluminum, brick, terra-cotta, ceramic and porcelain materials, concrete and natural stones. Some finishes or substrates may require a primer.
- **Movement Capacity** - can accommodate 50% movement in both extension and compression and has excellent recovery after cycling.
- **Low VOC Content** - significantly lower than the requirements of the U.S. Green Building Council's Leadership in Energy and Environmental Design (L.E.E.D.) program. Neutral cure byproduct with low odor.
- **Thermal Stability (cured state)** - once cured, the material remains flexible over a range of -55°F (-48°C) to 250°F (121°C) and up to 350°F (177°C) under intermittent short term exposure.

Application

- **Stable Consistency (uncured state)** - supplied as a lightweight paste, the consistency of which remains relatively unchanged over a wide temperature range. The paste may be easily gunned and tooled under hot and cold conditions.
- **Extended Work Life** - Designed to allow the user sufficient time for installation and tooling.
- **Low Sag or Slump** - Useful for application to horizontal, vertical or overhead surfaces.

continued

GE is a registered trademark of General Electric Company and is under license by Momentive Performance Materials Inc. Momentive Performance Materials provides versatile materials as the starting point for its creative approach to ideas that help enable new developments across hundreds of industrial and consumer applications. We are helping customers solve product, process, and performance problems; our silanes, fluids, elastomers, sealants, resins, adhesives, urethane additives, and other specialty products are delivering innovation in everything from car engines to biomedical devices. From helping to develop safer tires and keeping electronics cooler, to improving the feel of lipstick and ensuring the reliability of adhesives, our technologies and enabling solutions are at the frontline of innovation.



SCS9000 SilPruf* NB non-staining silicone weatherproofing sealant

Typical Performance Properties (continued)

Aesthetics

- **Premium Formulation** - special formulation offers a cleaner silicone option when sealing visible building joints. The cured sealant has a reduced tendency to attract airborne contaminants and minimize the subsequent streaking that can occur when rainwater washes over joints. The reduced dirt pickup characteristic allow it to be used as a substitute for organic sealants but with the delivery of traditional silicone weatherability and long life performance. In addition, the potential for staining from fluid migration is effectively reduced when sealing natural stones, including: marbles, granites and limestones.
- **Finish** - matte finish produces a non-glossy surface appearance.

Product Compatibility

- Full adhesive and chemical compatibility with SEC2400 SilShield* silicone elastomeric coating and US1100 UltraSpan* silicone pre-cured weatherstrip. Neutral cure byproduct with low odor.
- Compatible with the following silicone products: IGS3703, IGS3713-D1, IGS3723, IGS3743, SCS2000, SCS2350, SCS2700, SCS1800, SCS2800, US1100, SEC2400, SEC2500, SWS, SSG4000, SSG4000AC, SSG4800J, SSG4400, RGS7700, SSG4600, SSG4000E.

Basic Uses

SCS9000 is recommended for the following applications:

Natural Stone

- Useful on natural stones when staining from migration in undesired

Weatherproofing

- Between dissimilar or similar materials in either new or remedial glazing and sealing applications
- Around window perimeters and punched openings

Adhesive

- Useful for adhering US1100 and UST2200 UltraSpan pre-cured silicone weatherstrip product line



Packaging

SCS9000 is available in the following configurations:

- 10.1 fl oz (299 ml) plastic caulking cartridges
- 20 fl oz (591.5 ml) foil sausage packs
- 2 gallon (7.6 L) plastic pails
- 5 gallon (18.9 L) plastic pails

Colors

SCS9000 is available in custom colors along with 8 standard options.

Grade	Color
SCS9000.02	White
SCS9000.03	Black
SCS9000.04	Limestone
SCS9000.08	Light Grey
SCS9000.09	Aluminum Grey
SCS9000.10	Dark Grey
SCS9000.20	Precast White
SCS9000.97	Bronze

Limitations

SCS9000 is not recommended:

- for use underwater or in other applications where the product will be in continuous contact with water.
- for use in food contact applications.
- when painting of the cured sealant is desired (unless appropriate specialized paint products are used).

SCS9000 should not be applied or used:

- as a structural adhesive in Structural Glazing applications
- under exceedingly hot or cold conditions (see Sealant Application section for additional information).
- on wet, damp, frozen or contaminated surfaces.
- on excessively basic or acidic substrates.

Precautions

- This material requires atmospheric moisture to cure from paste to rubber and may not attain its listed final cured rubber properties when used in designs or applications where the silicone is encapsulated and without access to atmospheric moisture.
- Due to the inherent variability of natural materials it is recommended that stain testing be performed on all natural stone types prior to use to ascertain the visual acceptability of any particular sealant-stone combination. Contact Momentive Performance Materials (MPM) Technical Services for additional information.
- Some materials that bleed plasticizers or oils can cause a discoloration on the surface of sealants. When sealing to or over items such as: rubberized gaskets, bituminous-based materials, butyl or oil-based products, oily woods, tapes, etc., MPM recommends that compatibility testing be performed prior to application to confirm the suitability of these materials when in contact with each other.
- Silicone materials are hydrophobic in nature and if inadvertently over-applied onto adjacent joint surfaces (even if removed immediately), can create a waterproofing effect on some substrate types visible when the substrate is wet. See section on Masking.

Technical Services

Additional technical information and literature may be available. Laboratory testing & application engineering are available upon request. Contact MPM Technical Services for additional information.

Specifications

Typical property values of SCS9000 as supplied and cured are set forth in the tables below. Typical product data values should not be used as specifications. Assistance with specifications is available by contacting MPM at +1 (877) 943-7325.

Typical Properties – Supplied

Property	Value ⁽¹⁾	Test Method
Consistency	Paste	N/A
Polymer	100% silicone	N/A
VOC	37 g/l	WPSTM C1454
Work Life (tooling time)	30-40 minutes	N/A
Tack Free Time	1-2 hours (@ 73°F, 50% RH)	ASTM C679
Sag/Slump	0.1" max.	ASTM D2202

Typical Properties – Cured

Property	Value ⁽¹⁾	Test Method
Hardness, Durometer (Type A Indentor)	27	ASTM D2240
Ultimate Tensile Strength	244 psi (1.68 MPa)	ASTM D412
Ultimate Elongation	629%	ASTM D412
Tear Strength; die B	30.8 ppi	ASTM D624
Peel Strength (average) (21-day cure @ 73°F (23°C) 50% RH)	36.8 pli	ASTM C794
Joint Movement Capability	±50%	ASTM C719
Staining (Masonry)	none	ASTM C1248
Service Temperature Range (after cure)	-55°F to +250°F (-48°C to 121°C)	N/A
Weathering and U.V. Resistance	Excellent	GE 20 yr. study
Cure Time (1/4" or 6 mm deep section) @ 73°F (23°C) 50% RH	2-3 days	N/A
Full Cure (most common bead sizes)	10-14 days	N/A

(1) Average value. Actual value may vary.

Applicable Standards

SCS9000 meets or exceeds the requirements of the following specifications:

American Society for Testing & Materials International:

- ASTM C920 Standard Specification for Elastomeric Joint Sealants; Type S, Grade NS, Class 50, Use A, G, M, O

U.S. Federal Specifications: (widely referenced but cancelled Sept. 1996)

- TT-S-001543A Sealing Compound: Silicone Rubber Base (for Caulking, Sealing & Glazing in Buildings and Other Structures)
- TT-S-00230C Sealing Compound: Elastomeric Type, Single Component (for Caulking, Sealing & Glazing in Buildings and Other Structures)

Canadian General Standards Board (currently inactive)

CGSB-19.13-M87 Sealing Compound, One-Component, Elastomeric, Chemical Curing

International Organization for Standardization

- ISO 11600 - Type G & F - 25 LM



SEALANT • WATERPROOFING & RESTORATION INSTITUTE

Issued to: **Momentive Performance Materials**
 Product: **SCS9000 Silpruf NB**

C719: Pass Ext:+50% Comp:-50%

Substrate: Unprimed Glass and Aluminum and Primed and Unprimed Granite and Limestone
[Granite and Limestone substrates were primed with SS4044P Primer]

C661: Rating 35

Validation Date: 6/4/08 - 6/3/13

No. 608-9000613 Copyright © 2008

SEALANT VALIDATION
www.swrionline.org

SCS9000 SilPruf* NB non-staining silicone weatherproofing sealant

Suggested References

In addition to the guidelines provided on this datasheet, MPM recommends that designers and users of SCS9000 familiarize themselves with the latest editions of following industry guidelines and best practices:

- 1.) ASTM C1193 Standard Guide for Use of Joint Sealants.
- 2.) ASTM C1472 Standard Guide for Calculating Movement and Other Effects When Establishing Sealant Joint Width.
- 3.) SWR Institute's Applying Liquid Sealants Applicator Training Program.

Joint Designs and Dimensions

Joint Movement

The dimensions of joints in typical construction applications change daily as a result of solar heat gain and building sway, and throughout the year due to seasonal changes. The movement in a sealant bead installed on the sun-side of a building or during the hottest portion of the day will be almost entirely in extension during the cold season or cycle, while the movement of a bead installed during the coldest condition will be almost entirely in compression during the hotter season or cycle. In addition to these above movements, the designer should consider the effect of construction tolerances in his/her project to minimize the occurrence of over-sized or under-sized joints during construction. All moving (dynamic) joints must be designed so as not to allow three-sided adhesion of the sealant to occur (reference ASTM C1193). Three-sided adhesion hinders the ability of the sealant to extend and compress freely as desired and can lead to early joint failure.

Joint Width

When using SCS9000, the designed joint width must be at least twice the total anticipated joint movement. For example, if the total anticipated movement in an expansion joint in which SCS9000 is to be installed is 1/4" (6 mm), the designed joint width must be at least 1/2" (12 mm). The designer may want to consider additional width to accommodate construction tolerances (reference ASTM C1472). Large panels or lites should allow a minimum width of 1/4" (6 mm) for the sealant bead, mostly to allow for a proper installation (very small/narrow beads become difficult to install and can accommodate less movement). Glazing of plastic or larger-sized metal panels may require larger than usual joint widths due to the greater movement potential (higher coefficients of thermal expansion). Consult with MPM Technical Services for recommendations on large or unusual applications.

Butt Jointing

A thin installation of silicone sealant can better accommodate more movement than a deep installation, as the deeper bead will result in additional stress being imposed on both the sealant and the bonding surfaces during joint movement.

Figure 1 illustrates the general guidelines for installation of SCS9000 into a typical butt joint configuration of widths up to 2" (5 cm).

The recommended sealant profile is as follows:

- is an hourglass shape with the depth of the sealant over the crown of the backer rod to be no thinner than 1/8" (3 mm) and no thicker than 3/8" (10 mm), and
- a minimum of 1/4" (6 mm) of adhesive bonding contact must be made to all surfaces to which the sealant is to adhere.

When used in joints exceeding 2" (5 cm) in width the recommended sealant profile is as follows:

- is an hourglass shape with the depth of the sealant over the crown of the backer rod to be no thinner than 1/4" (6 mm) and no thicker than 3/8" (10 mm), and
- a minimum of 3/8" (10 mm) of adhesive bonding contact must be made to all surfaces to which the sealant is to adhere.

Figure 1

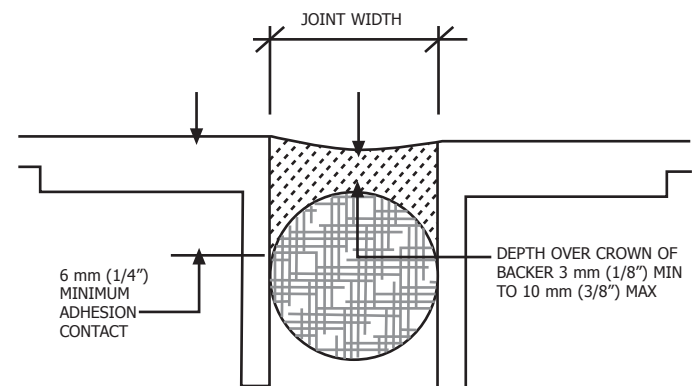

Joint Backer Materials

Backer materials, typically the backer rod, provides the following benefits to aide in the correct application of SCS9000:

- 1.) Controls and provide the desired sealant depth.
- 2.) Creates a formed joint cavity that allows for the desired hourglass sealant shape.
- 3.) Provides a firm backup that helps attain full wetting of the substrates when the sealant is tooled.
- 4.) Acts as a bond breaker to eliminate adhesion on the backside of a joint (three-sided adhesion).

A non-gassing polyethylene, polyolefin or a polyurethane foam rod is the recommended back-up material for use with SCS9000. If the joint is too shallow to allow foam rod, use a polyethylene tape (as a bond breaker to eliminate three-sided adhesion). On porous substrate applications, a closed cell backer rod is recommended (open cell backer materials absorb and hold water which can affect long-term sealant adhesion on these materials). The Backer rod should be 25-50% greater (confirm with manufacturer of backer rod as to type selected) than the width of the joint, thereby providing continuous pressure against the joint walls; and expanding and contracting with the joint movement without pushing the sealant out of the joint during the compression cycle or falling away during the extension cycle. Rubber backup materials may stain the sealant and are not recommended, unless tested and verified for compatibility.

Installation

Sealants may not adhere or maintain long-term adhesion to substrates if the surface is not prepared and cleaned properly before sealant application. Using proper materials and following prescribed surface preparation and cleaning procedures is vital for sealant adhesion. **IN ALL CASES IT IS IMPORTANT TO CONFIRM THE ACCEPTIBILITY OF EACH SEALANT-SUBSTRATE COMBINATION WITH A LAB OR SITE ADHESION TEST PRIOR TO PROCEEDING WITH PROJECT INSTALLATION.** MPM can provide lab and field adhesion testing information and suggestions to user upon request.

Difficult or nearly impossible to see on a joint substrate, frost is likely to develop on substrates when temperatures drop near the freezing point. Since frost and moisture will interfere with proper sealant adhesion, it is important to confirm that substrates are dry prior to application of the sealant.

Surface Preparation

Porous Materials (concrete, masonry, brick, stone, etc.)

- Joints must be clean, dry and sound prior to application of the sealant. All contaminants, impurities, or other adhesion inhibitors (such as moisture/frost, oils, concrete form release agents, old sealants, asphalt and other surface treatments, etc.) must be removed from the surfaces to which the sealant is intended to adhere.
- Clean where necessary by wire brush, mechanical abrading, grinding, sanding, saw cutting, blast cleaning (sand or water), or a combination of these methods to provide a stable clean surface for sealant application.
- Remove dust and other remaining loose particles with a soft bristle brush or by using an oil-free air blow.
- Polished stone surfaces and smooth sawn edges can be cleaned using a solvent dampened rag (allow sufficient time for solvent to evaporate prior to application of the sealant). When handling solvents, refer to manufacturer's MSDS for information on handling, safety and personal protective equipment.
- Cleaning of surfaces should be done within 1 to 2 hours of when the sealant is to be applied.
- Since porous materials can absorb and retain moisture, it is important to confirm that substrates are dry prior to application of the sealant.

Non-Porous Materials (glass, metals, plastics, ceramics, etc.)

- Clean by using a two-rag wipe technique — wet one rag with solvent and wipe the surface with it, then use the second rag to wipe the wet solvent from the surface **BEFORE** it evaporates (allowing the solvent to dry on the surface without immediately wiping with a second cloth can negate the cleaning procedure because the contaminants may simply be re-deposited as the solvent dries). In all cases where used, solvents should be wiped dry with a clean, white cloth or other lint-free wiping material. Change the cleaning rags frequently, as they become dirty. It is easier to see the dirt accumulating on the rag if white rags are used. Do not dip used cleaning rags into the cleaning solvent as this can contaminate the solvent (cleaning with contaminated solvent can result in sealant adhesion issues). Always use clean solvent-resistant containers for solvent use and storage.
- Isopropyl Alcohol (IPA) is a commonly-used solvent and has proven useful for most non-porous substrates encountered in architectural construction applications. Xylene and Toluene have also been found useful on many substrates. When handling solvents, refer to manufacturer's MSDS for information on handling, safety and personal protective equipment.
- Architectural coatings, paints and plastics should be cleaned with a solvent approved by the manufacturer of the product or which does not harm or alter the finish. Cleaning of surfaces should be done within 1 to 2 hours of when the sealant is to be applied.

Priming

SCS9000 attains primerless adhesion to many commonly encountered construction materials. However, some materials with variable surface characteristics may require the use of a primer to help obtain durable long-term adhesion. Prior to use, trial applications should be made to check adhesion to the specific materials to be used on the project. See the MPM primer datasheets for product specific information on use and priming instructions. **PRIMER APPLICATION IS NOT A SUBSTITUTE FOR SURFACE PREPARATION.** Consult MPM Technical Services for sealant/primer/substrate recommendations. **CAUTION:** primers may contain solvents. When handling solvents, refer to manufacturer's MSDS for information on handling, safety and personal protective equipment.

Masking

Where appropriate, the use of masking tape is recommended to ensure a neat job and to protect adjoining surfaces from over-application of sealant. Masking tape can prevent contact of sealant with adjoining surfaces that otherwise would be permanently marred or damaged by such contact or by cleaning methods required to remove the sealant. When tooling, use care not to spread the sealant over the face of the substrates adjacent to the joint or masking as the silicone can be extremely difficult to remove on rough or porous substrates. Do not allow masking tape to touch clean surfaces to which the silicone sealant is to adhere (adhesive on masking tape can interfere with adhesion of silicone). Masking tape should be removed immediately after tooling the sealant and before the sealant begins to cure (tooling time).

SCS9000 SilPruf* NB non-staining silicone weatherproofing sealant

Installation (continued)

Sealant Application

- Apply sealant in a continuous operation, horizontally in one direction and vertically from the bottom to the top of the joint opening, applying positive pressure adequate to properly fill and seal the joint width.
- Tool or strike the sealant with a concave tool applying light pressure to spread the material against the back-up material and the joint surfaces to ensure a void-free application.
- In glazing applications, tool the sealant at the sill so that precipitation and cleaning solutions will not pool.
- Excess sealant should be cleaned from glass, metal and plastic surfaces while still uncured. On porous surfaces the excess sealant should be allowed to progress through the initial cure or set-up. It should then be removed by abrasion or other mechanical means.
- Due to the smooth consistency of SCS9000, tooling agents such as water, soap, or detergent solutions are not necessary or recommended. Dry tooling is recommended.
- Sealant is best applied when the temperature is above 40°F (4°C) as frost or moisture are less likely to be present on the surfaces to be sealed. However, SCS9000 can be applied in colder temperatures; refer to MPM technical bulletin "Cold Weather Sealing Guidelines" for additional information.
- The cure rate of this product is dependent upon temperature and the availability of atmospheric moisture. Under Standard Conditions (relative humidity of 50 ± 5% at an air temperature of 23 ± 1°C [73.4 ± 2°F]) this material can attain a cured thickness of 2-3 mm per 24 hours (assuming ample access to atmospheric moisture). As temperature decreases, the cure rate slows down (and vice versa). Low moisture environments will also reduce the cure rate. Near-confined spaces which limit the overall access to atmospheric moisture will cure only from that surface which has access to the atmosphere. Colder temperatures can significantly increase cure times and can open the possibility of sealant irregularities if joint movement occurs while sealant is not fully cured. The following reference provides additional information on Movement-During-Cure of sealant joints: ASTM C1193 – Standard Guide for Use of Joint Sealants; section 12.5.

SCS9000 SilPruf* NB non-staining silicone weatherproofing sealant

Patent Status

Nothing contained herein shall be construed to imply the nonexistence of any relevant patents or to constitute the permission, inducement or recommendation to practice any invention covered by any patent, without authority from the owner of the patent.

Product Safety, Handling and Storage

Customers considering the use of this product should review the latest Material Safety Data Sheet and label for product safety information, handling instructions, personal protective equipment if necessary, and any special storage conditions required. Material Safety Data Sheets are available at www.ge.com/silicones or, upon request, from any MPM representative. Use of other materials in conjunction with MPM sealants products (for example, primers) may require additional precautions. Please review and follow the safety information provided by the manufacturer of such other materials.

Emergency Service

Momentive Performance Materials maintains an around-the-clock emergency service for its products.

<u>Location</u>	<u>Emergency Service Provider</u>	<u>Emergency Contact Number</u>
Mainland U.S., Puerto Rico	CHEMTREC	1-800-424-9300
Alaska, Hawaii	CHEMTREC	1-800-424-9300
Canada	CHEMTREC	1-800-424-9300
Europe, Israel	NCEC	+44 (0) 1235239670
Middle East	NCEC	+44 (0) 1235239671
Asia Pacific (except China)	NCEC	+44 (0) 1235239670
China	NCEC	+86-10-5100-3039
Latin America (except Brazil)	NCEC	+44 (0) 1235239670
Brazil	SOS Cotec	08000111767 or 08007071767
All other locations world wide	NCEC	+44 (0) 1235239670
At sea	Radio U.S. Coast Guard in U.S. waters NCEC in International waters	+44 (0) 1235239670

For Health related calls, contact Momentive Performance Materials at +1-518-233-2500 (English only).

DO NOT WAIT. Phone if in doubt. You will be referred to a specialist for advice.

CUSTOMER SERVICE CENTERS

North America

E cs-na.silicones@momentive.com

• Specialty Fluids	T +1.800.523.5862	F +1.304.746.1654
• UA, Silanes and Specialty Coatings	T +1.800.334.4674	F +1.304.746.1623
• RTVs and Elastomers	T +1.800.332.3390	F +1.304.746.1623
• Consumer Sealants & Construction Sealants and Adhesives	T +1.877.943.7325	F +1.304.746.1654

Latin America

E cs-la.silicones@momentive.com

• Argentina & Chile	T +54.11.4862.9544	F +54.11.4862.9544
• Brazil	T +55.11.4534.9650	F +55.11.4534.9660
• Mexico & Central America	T +52.55.2169.7670	F +52.55.2169.7699
• Venezuela, Ecuador, Peru Colombia & Caribbean	T +58.212.285.2149	F +58.212.285.2149

Europe, Middle East, Africa and India

E cs-eur.silicones@momentive.com

T 00.800.4321.1000

Pacific

E cs-ap.silicones@momentive.com

T +1.800.820.0202
T +0.81.276.20.6182
F +81.276.31.6259

Worldwide Hotline

T +1.607.786.8131
T +1.800.295.2392
F +1.607.786.8309

Visit us at www.ge.com/silicones

THE MATERIALS, PRODUCTS AND SERVICES OF MOMENTIVE PERFORMANCE MATERIALS INC., MOMENTIVE PERFORMANCE MATERIALS USA INC., MOMENTIVE PERFORMANCE MATERIALS ASIA PACIFIC PTE. LTD., MOMENTIVE PERFORMANCE MATERIALS WORLDWIDE INC., MOMENTIVE PERFORMANCE MATERIALS GmbH, THEIR SUBSIDIARIES AND AFFILIATES DOING BUSINESS IN LOCAL JURISDICTIONS (collectively "SUPPLIERS"), ARE SOLD BY THE RESPECTIVE LEGAL ENTITY OF THE SUPPLIER SUBJECT TO SUPPLIERS' STANDARD CONDITIONS OF SALE, WHICH ARE INCLUDED IN THE APPLICABLE DISTRIBUTOR OR OTHER SALES AGREEMENT, PRINTED ON THE BACK OF ORDER ACKNOWLEDGMENTS AND INVOICES, AND AVAILABLE UPON REQUEST. ALTHOUGH ANY INFORMATION, RECOMMENDATIONS, OR ADVICE CONTAINED HEREIN IS GIVEN IN GOOD FAITH, SUPPLIERS MAKE NO WARRANTY OR GUARANTEE, EXPRESS OR IMPLIED, (i) THAT THE RESULTS DESCRIBED HEREIN WILL BE OBTAINED UNDER END-USE CONDITIONS, OR (ii) AS TO THE EFFECTIVENESS OR SAFETY OF ANY DESIGN INCORPORATING SUPPLIERS' PRODUCTS, MATERIALS, SERVICES, RECOMMENDATIONS OR ADVICE. AFOREMENTIONED EXCLUSIONS OR LIMITATION OF LIABILITY ARE NOT APPLICABLE TO THE EXTENT THAT THE END-USE CONDITIONS AND/OR INCORPORATION CONDITIONS CORRESPOND TO THE RECOMMENDED CONDITIONS OF USE AND/OR OF INCORPORATION AS DESCRIBED BY SUPPLIER IN ITS PRODUCT DATA SHEET AND/OR PRODUCT SPECIFICATIONS. EXCEPT AS PROVIDED IN SUPPLIERS' STANDARD CONDITIONS OF SALE, SUPPLIERS AND THEIR REPRESENTATIVES SHALL IN NO EVENT BE RESPONSIBLE FOR ANY LOSS RESULTING FROM ANY USE OF ITS MATERIALS, PRODUCTS OR SERVICES DESCRIBED HEREIN.

Each user bears full responsibility for making its own determination as to the suitability of Suppliers' materials, services, recommendations, or advice for its own particular use. Each user must identify and perform all tests and analyses necessary to assure that its finished parts incorporating Suppliers' products, materials, or services will be safe and suitable for use under end-use conditions. Nothing in this or any other document, nor any oral recommendation or advice, shall be deemed to alter, vary, supersede, or waive any provision of Suppliers' Standard Conditions of Sale or this Disclaimer, unless any such modification is specifically agreed to in a writing signed by Suppliers. No statement contained herein concerning a possible or suggested use of any material, product, service or design is intended, or should be construed, to grant any license under any patent or other intellectual property right of Suppliers or any of its subsidiaries or affiliates covering such use or design, or as a recommendation for the use of such material, product, service or design in the infringement of any patent or other intellectual property right.

*SilShield and SilPruf are trademarks of Momentive Performance Materials Inc.
GE is a registered trademark of General Electric.
Copyright 2012 Momentive Performance Materials Inc. All rights reserved.

161-046-10E-GL
CDS: DataSCS9000 (02/12)