



PROPER INSTALLATION OF APA RATED SHEATHING FOR ROOF APPLICATIONS

Like all construction materials, APA Rated Sheathing panels must be installed correctly to insure best performance. Nearly all roof sheathing complaints are due to incorrect installation. Following these simple construction steps will provide best performance and minimize complaint callbacks.

STEP 1. Always check for level nailing surface. This can be done with a piece of lumber (6 feet to 10 feet long) or a long carpenter's level. Trusses or rafters should be shimmed as necessary to provide a level nailing surface.

If top chords of trusses or rafters are warped or bowed, install blocking to straighten.

STEP 2. Provide roof ventilation according to building codes (see *hints* below).

Ventilation hints

1. Minimum net free ventilation area of 960 square inches for each 1,000 square feet of ceiling area is required. When vents are located at eaves or soffits and near peak or along ridge for maximum air flow, free vent area may be reduced (minimum 480 square inches per 1,000 square feet).
2. Vent exhaust air from kitchens and bath to outdoors with vent pipes that run through the roof cavity or attic to roof ventilators. **Do not vent exhaust air directly into roof cavity or attic.**
3. Install baffles providing a minimum of 1 inch of clear space between framing and/or under roof sheathing at eaves to

insure that ceiling or roof insulation does not block ventilation paths. For vaulted or cathedral roof construction, provide free ventilation path from eaves to ridge between all rafters.

STEP 3. Panels should be fastened with a minimum of 8d common nails spaced at a maximum of 6 inches on center at supported panel ends and edges. At intermediate supports, fasten panels 12 inches on center. In high wind areas more fasteners may be required. Fasteners should be nominally 3/8 inch from panel ends and 3/8 inch from panel edges (see hints on following page). **For pitched roofs wear skid-resistant shoes. Place screened surface of panel or side with skid-resistant coating up.**

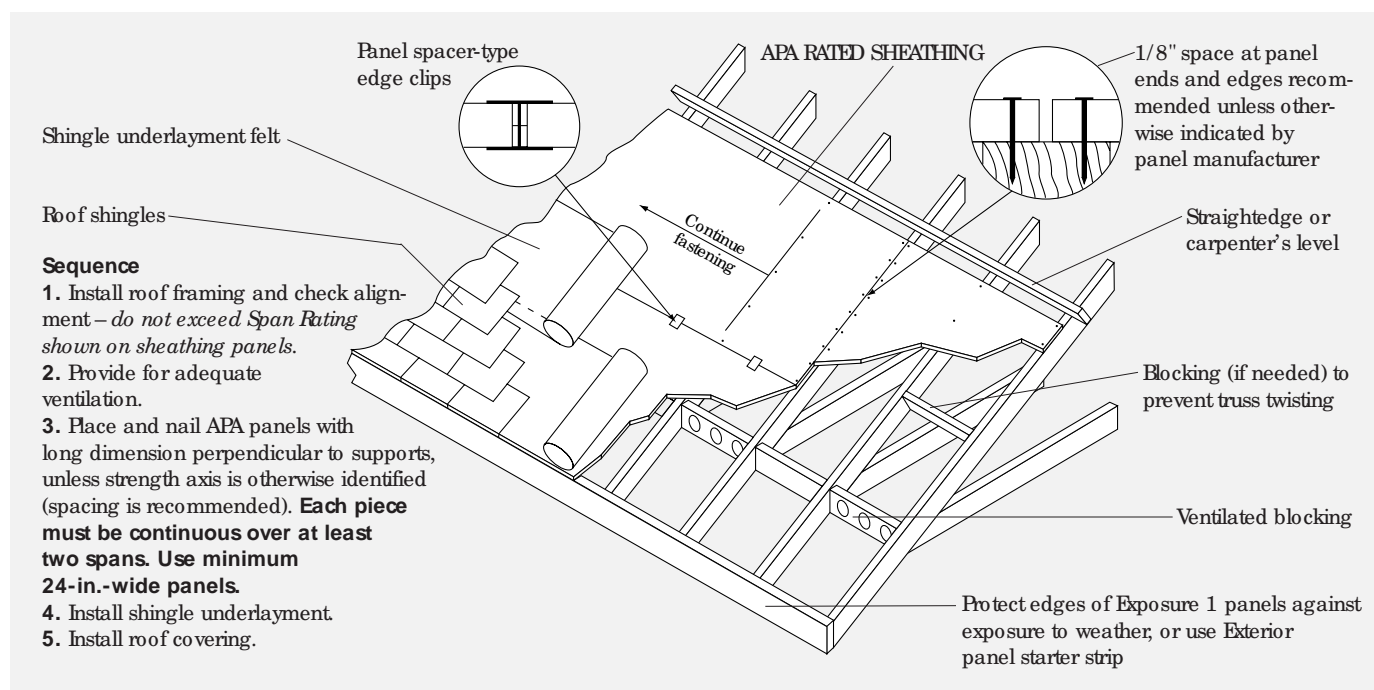

A P A

The Engineered Wood Association

BAFFLES TO PROVIDE ATTIC VENTILATION

Preformed baffles
(several types available)

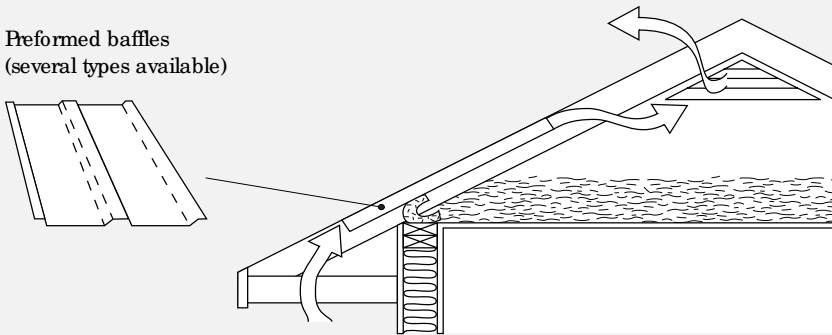

Fastening hints

1. Position panel. Use temporary fasteners at corners if needed to square panel on framing.
2. Install fasteners at one panel end.
3. Remove temporary fasteners at corners.
4. Install intermediate fasteners, starting at panel edge. Use chalk line or straight edge to align fasteners on framing. Fasten panels in rows across the width, continuing this sequence along the length of the panel. This procedure keeps internal stress from accumulating in panels.
5. Stand on panel over framing near the fastener location to insure contact with framing while driving fasteners. Fasteners should be driven flush with the panel surface.
6. For improved performance, consider thicker roof sheathing panels, panel edge clips, or panels with tongue-and-groove edges.
7. When installing panels, a 1/8-inch space between adjacent panel end and edge joints is recommended, unless panel manufacturer indicates otherwise. Check building code requirements for installation of panel edge clips. Edge clip requirements depend on the relationship of the panel Span Rating to the actual distance between roof framing.

Spacing hints

1. Use a 10d box nail as a spacer to gauge 1/8-inch edge and end spacing between panels.
2. Spacer-type panel edge clips are available from some manufacturers.
3. If necessary, trim panel ends to center on framing.

STEP 4. Cover sheathing with shingle underlayment felt as soon as possible to minimize roof sheathing exposure to weather, unless otherwise recommended by sheathing manufacturer.

Roofing hints

1. Use shingle underlayment felt conforming to ASTM D-226, or check roofing manufacturer's recommendations if delays are anticipated during construction.
2. Remove wrinkles and flatten surface of shingle underlayment before installing asphalt or fiberglass shingles.

STEP 5. Install shingles according to manufacturer's recommendations.

Shingle hints

1. If using asphalt or fiberglass shingles, postpone shingle installation as long as possible. This will provide time for roof sheathing to adjust to humidity and moisture conditions.
2. For best appearance, use heavier weight shingles, or laminated or textured shingles. This will mask surface

imperfections and reduce the risk of shingle ridging.

Additional Information

For more complete information, contact APA – The Engineered Wood Association for the following literature:

- *APA Design/Construction Guide: Residential & Commercial, Form E30.*
- *How to Minimize Buckling of Asphalt Shingles, Form K310.*
- *Condensation – Causes and Control, APA Technical Note X485.*

We have field representatives in most major U.S. cities and in Canada who can help answer questions involving APA trademarked products. For additional assistance in specifying APA engineered wood products, get in touch with your nearest APA regional office. Call or write:

WESTERN REGION

7011 So. 19th St. ■ P.O. Box 11700
Tacoma, Washington 98411-0700
(253) 565-6600 ■ Fax: (253) 565-7265

EASTERN REGION

2130 Barrett Park Drive, Suite 102
Kennesaw, Georgia 30144-3681
(770) 427-9371 ■ Fax: (770) 423-1703

U.S. HEADQUARTERS AND INTERNATIONAL MARKETING DIVISION

7011 So. 19th St. ■ P.O. Box 11700
Tacoma, Washington 98411-0700
(253) 565-6600 ■ Fax: (253) 565-7265

PRODUCT SUPPORT HELP DESK

(253) 620-7400

E-mail Address: help@apawood.org

(Offices: Antwerp, Belgium; Bournemouth, United Kingdom; Hamburg, Germany; Mexico City, Mexico; Tokyo, Japan.) For Caribbean/Latin America, contact headquarters in Tacoma.

The product use recommendations in this publication are based on APA – The Engineered Wood Association's continuing programs of laboratory testing, product research, and comprehensive field experience. However, because the Association has no control over quality of workmanship or the conditions under which engineered wood products are used, it cannot accept responsibility for product performance or designs as actually constructed. Because engineered wood product performance requirements vary geographically, consult your local architect, engineer or design professional to assure compliance with code, construction, and performance requirements.

Form No. N335J
Revised March 1999/0010

A P A

The Engineered Wood Association

