

KWIK Bolt 3 Expansion Anchor 3.3.6

3.3.6.5 Installation Instructions

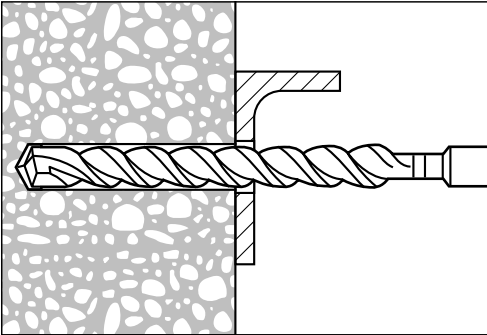

1. Hammer drill a hole to the same nominal diameter as the KWIK Bolt 3. The hole depth must exceed the anchor embedment by at least one diameter. The fixture may be used as a drilling template to ensure proper anchor location.

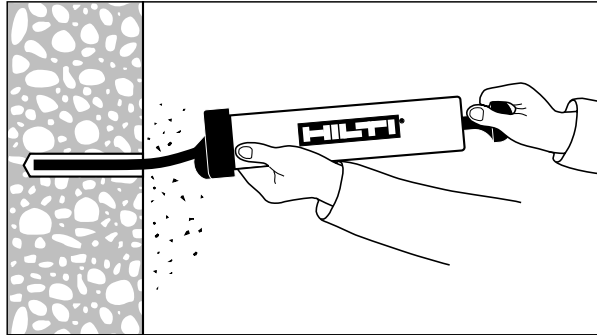

2. Clean hole.

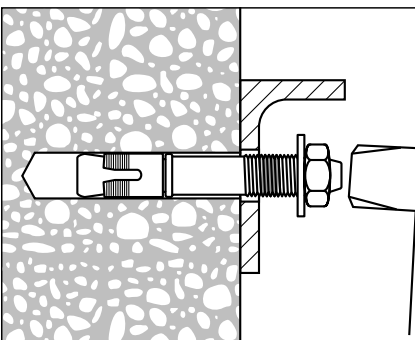

3. Drive the KWIK Bolt 3 into the hole using a hammer. The anchor must be driven until at least 6 threads are below the surface of the fixture.

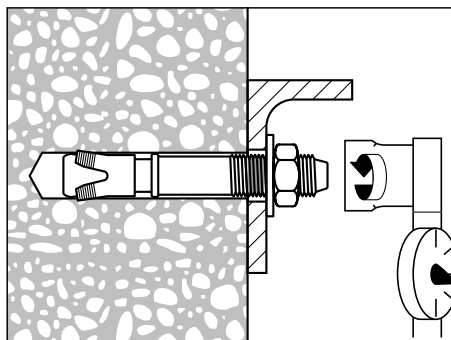

4. Tighten the nut to the installation torque.

3.3.6 KWIK Bolt 3 Expansion Anchor

Countersunk KWIK Bolt 3 Anchor Installation Instructions

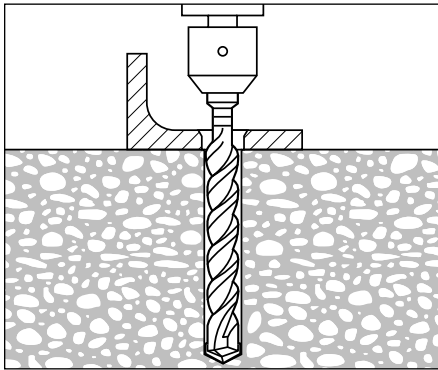

1. Drill.

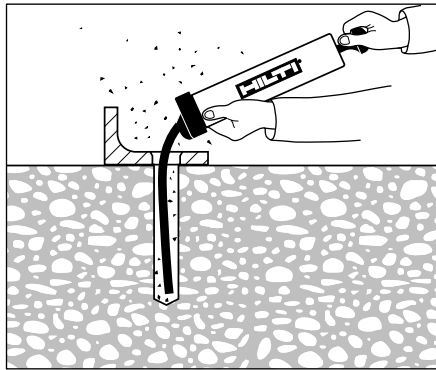

2. Clean.

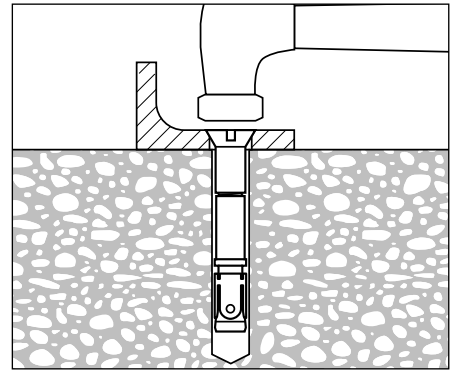

3. Thread post nut completely onto anchor. Tap into hole.

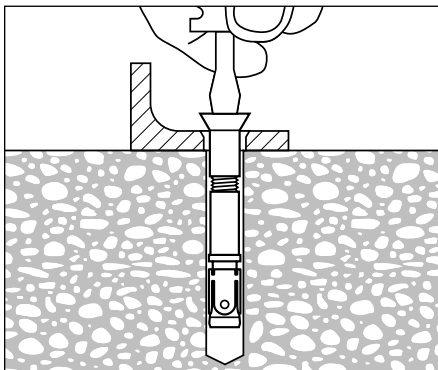

4. Loosen screw two full turns.

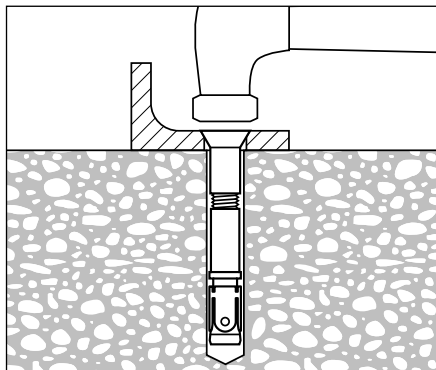

5. Tap-in again.

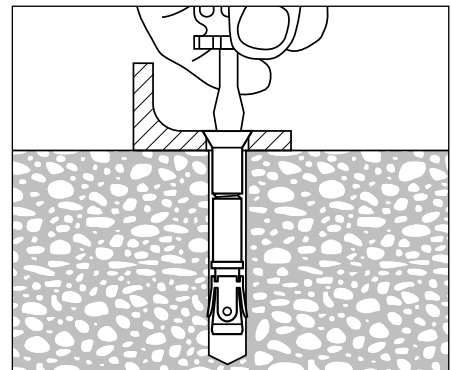

6. Tighten.

Rod Coupling KWIK Bolt 3 Anchor Installation Instructions

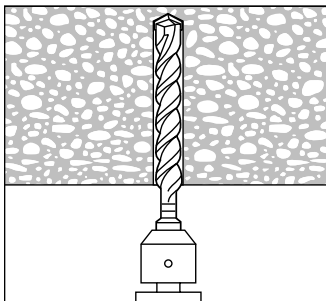

1. Drill.

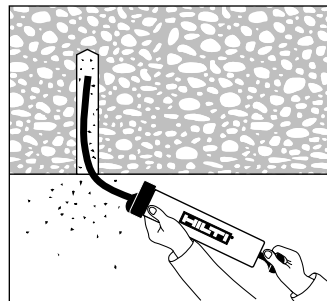

2. Clean.

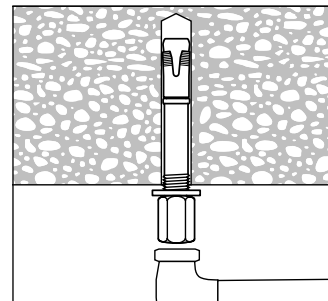

3. Tap-in.

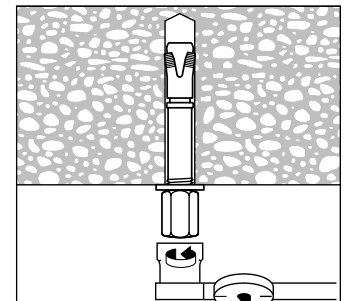

4. Tighten.

Hilti Ceiling KWIK Bolt (HHDCA) Anchor Installation Instructions

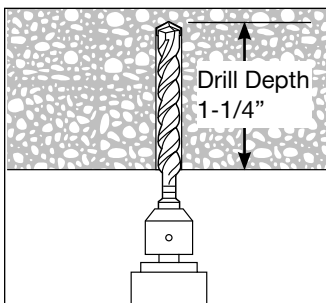

1. Drill hole using 1/4" bit.

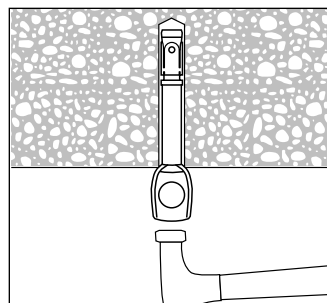

2. Tap in.

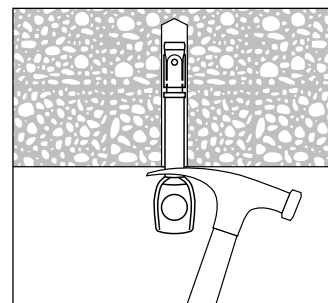

3. Pry downward.