



HOHMANN & BARNARD, INC.
A MiTek - BERKSHIRE HATHAWAY COMPANY

Flashing and Reglets

Mighty-Flash™-SA

Self Adhering Stainless Steel Fabric Flashing

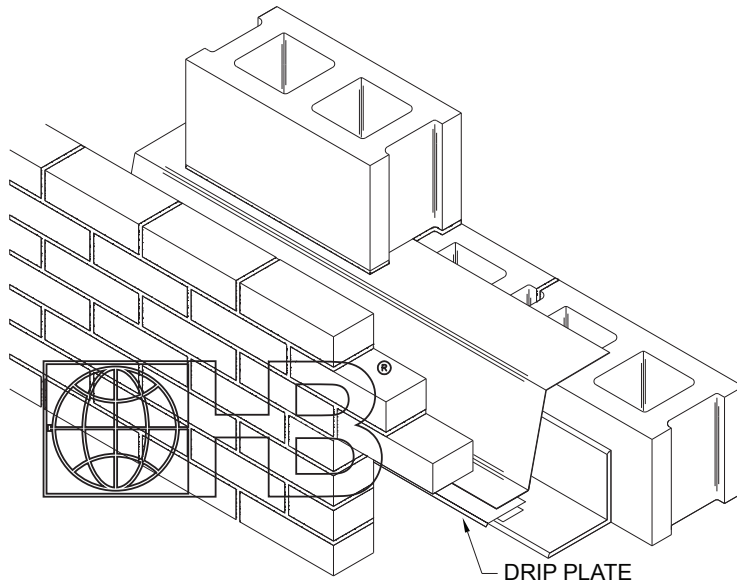
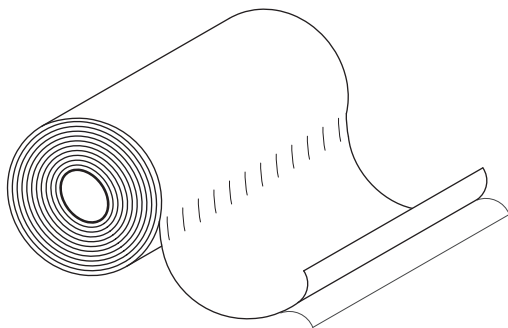

DRAWINGS FOR ILLUSTRATIVE PURPOSES ONLY

Technical Data:

Puncture (PSI)	ASTM E154	2,500+
Tensile	ASTM D412	100,000+
Fire Resistant	ASTM E84	Pass
Mold Resistant	ASTM D3273	Pass

Description & Benefits:

Mighty-Flash™-SA is a self-adhering stainless steel fabric flashing product with a removable release liner for easy application. The proprietary clear adhesive is factory-laminated to a Class A material consisting of a layer of polymeric fabric with a single sheet of 304 stainless steel bonded to one side. It is an innovative product featuring excellent puncture and tear resistance, designed to last for the life of the wall.

- Clear, non-asphaltic, pressure-sensitive, adhesive will not drool when exposed to UV or heat.
- Removable release liner for easy application
- Flexible and easy to form on the jobsite
- Rolls are 60' long
- Membrane thickness .004 in
- Stainless Steel thickness: .003 in
- Available in 12", 16", 18", 24" & 36" widths
- Fire resistant: ASTM E84 tested, a Class A material
- Mold resistant: ASTM D3273 tested
- Heat resistant: no degradation in high heat applications
- UV-resistant for up to 180 days.
- 60% Recycled Content
- Recyclable
- Lifetime Warranty

* Please refer to Hohmann & Barnard installation instructions for more information.

Width: (60 ft. rolls)

- 12" 16" 18" 24" 36"

Stainless Steel Drip Plate:

- 1 1/2" 3" Other _____

Flex-Flash® Drip Edge:

- 3"

Termination Bar:

- Stainless Steel (Type 304)
 Plastic

- Primer-SA** (5 gal. pail)
(Water-Based Primer for Self-Adhering Flashing)

- H&B 1-Quart Mastic Tube**

- H&B Mastic** (5 gal. pail)

- X-Seal Splice Tape** (4" wide)

IMPORTANT: Since each construction project is unique, the appropriate selection and use of any product contained herein must be determined by competent architects, engineers and other appropriate professionals who are familiar with the specific requirements of the project in question.

HOHMANN & BARNARD, Inc.
30 Rasons Court | Hauppauge, NY 11788
CORPORATE HEADQUARTERS
T: 800.645.0616 F: 631.234.0683
www.h-b.com

Branch/Subsidiary Locations:
ALABAMA - ILLINOIS - MARYLAND
NEW YORK - PENNSYLVANIA - TEXAS
UTAH - CANADA

© HOHMANN & BARNARD, INC. - 2014