



Wall Switch Occupancy Sensors

LightHawk™ Multi-Technology Dual Circuit Wall Switch Sensor featuring IntelliDAPT®

KEY FEATURES

- All-digital dual technology (ultrasonic [US] and passive infrared [PIR]) sensor
- IntelliDAPT self-adaptive technology—no manual adjustment required
- 2 relays for either two-level switching or dual-circuit control
- Auto-on and manual-on operating modes (depending on model)
- 1,000 square-foot, 180° coverage area (major motion)
- Built-in photocell with SuperSaver™ mode
- RhinoTuff™ lens
- Dual 120/277 VAC operation
- No minimum load requirement
- Zero Arc Point Switching
- ETL, UL, and cUL listed
- 5-year warranty



LHMTD2



LHMTD0

OVERVIEW

LHMTD sensors combine ultrasonic (US) and passive infrared (PIR) technologies for unequaled occupancy detection and false trip immunity, providing improved accuracy. The sensors, designed for dual-level lighting applications, possess 2 primary circuits (each with independent switching).

LHMTD sensors feature Hubbell Building Automation’s patented IntelliDAPT technology, which makes all the sensor adjustment decisions automatically. Throughout the product’s lifespan, smart software analyzes the controlled area and makes digital adjustments to sensitivity and timer settings. Occupancy sensors with IntelliDAPT provide a maintenance-free “Install and Forget” operation. With selectable operating modes—auto on/off or manual on/auto off—and a built-in photosensor for automatic daylight harvesting, LHMTD sensors are the most capable choice in today’s market place.

FEATURES and BENEFITS

Features	Benefits
IntelliDAPT technology	<ul style="list-style-type: none"> • Sensor automatically determines the ideal setting for an area • No manual sensitivity or timer adjustments required • Provides a maintenance-free “Install and Forget” operation
All-digital dual technology (ultrasonic [US] and passive infrared [PIR]) sensor	<ul style="list-style-type: none"> • Superior US minor-motion detection with excellent PIR long-range motion detection
2 relays for either two-level switching or dual-load control	<ul style="list-style-type: none"> • Controls two circuits (120 VAC and/or 277 VAC) independently
Auto-on and manual-on operating modes (depending on model)	<ul style="list-style-type: none"> • Provides auto-on/auto-off and manual-on/auto-off operations
Tamper-proof automatic-only version available	<ul style="list-style-type: none"> • Automatically turns lighting on and off without requiring you to push a button
RhinoTuff lens	<ul style="list-style-type: none"> • Impact-resistant infrared (IR) lens
Built-in photocell with optional SuperSaver mode	<ul style="list-style-type: none"> • Increases energy savings by preventing lights from turning on when there is sufficient natural light

- Optional SuperSaver mode—turns lights off during periods of occupancy if there is enough natural light to illuminate the area

SPECIFICATIONS

Timer timeout	<ul style="list-style-type: none"> • Auto mode: 4–30 minutes (self-adjusts based on occupancy) • Fixed mode: 4, 8, 15, and 30 minutes • Test mode: 5 seconds
Ultrasonic (US) output	<ul style="list-style-type: none"> • 40kHz output
Passive infrared (PIR)	<ul style="list-style-type: none"> • Dual-element pyrometer and 12-element cylindrical RhinoTuff lens
Photocell	<ul style="list-style-type: none"> • Natural light override range: 10–500 foot-candles
Coverage	<ul style="list-style-type: none"> • 1,000 square-foot, 180° coverage area
Power requirements	<ul style="list-style-type: none"> • 120/277 VAC, 50/60Hz
Electrical ratings	<ul style="list-style-type: none"> • 120VAC: 800W Incandescent; 1,000W Fluorescent; 1/6 HP • 277VAC: 1,800W Fluorescent; 1/6 HP
Load requirements	<ul style="list-style-type: none"> • None
Operating environment	<ul style="list-style-type: none"> • Indoor use only • Operating temperature: 32°–104°F (0°–40°C) • Relative humidity (non-condensing): 0–95%
Construction	<ul style="list-style-type: none"> • Casing—high-impact injection-molded plastic (UL-94-5V) • Impact-resistant lens • Color-coded leads are 6" long
Size and weight	<ul style="list-style-type: none"> • Size: 4.2" x 1.8" x 2.1"; .37" extension • Weight: 2.9 oz
Color	<ul style="list-style-type: none"> • White; Ivory; Light Almond; Gray; Black
Mounting	<ul style="list-style-type: none"> • Single-gang NEMA-style switch box (average switch box) • Decorator-style wall plate not included
Certifications	<ul style="list-style-type: none"> • ETL, UL, and cUL listed
Warranty	<ul style="list-style-type: none"> • 5 years

HOW TO ORDER

Catalog Number	Description
LHMTD2*	Ultrasonic and PIR Dual Circuit Wall Switch Sensor with IntelliDAPT and Automatic/Manual Control, 120/277VAC
LHMTD0*	Ultrasonic and PIR Dual Circuit Wall Switch Sensor with IntelliDAPT and Automatic Only Control, 120/277VAC

* = W – White, I – Ivory, A – Light Almond, G – Gray, B – Black

RANGE DIAGRAM

*Refer to Application Guide.

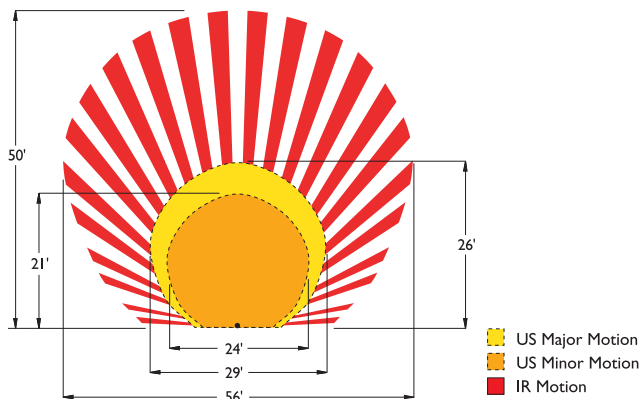

WIRING DIAGRAM

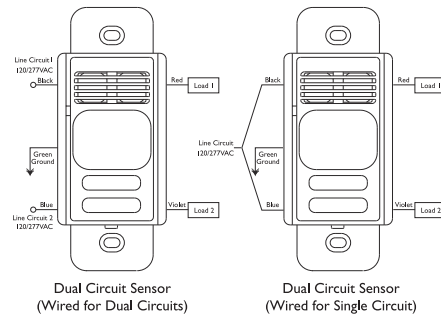

Building Automation, Inc.

Hubbell Building Automation, Inc.
 9601 Dessau Road | Building One | Austin, Texas 78754
 {512} 450-1100 | {512} 450-1215 fax
hubbell-automation.com