

OWNERS MANUAL

GROUT PUMP, MODEL GP-7 SUPPLEMENT

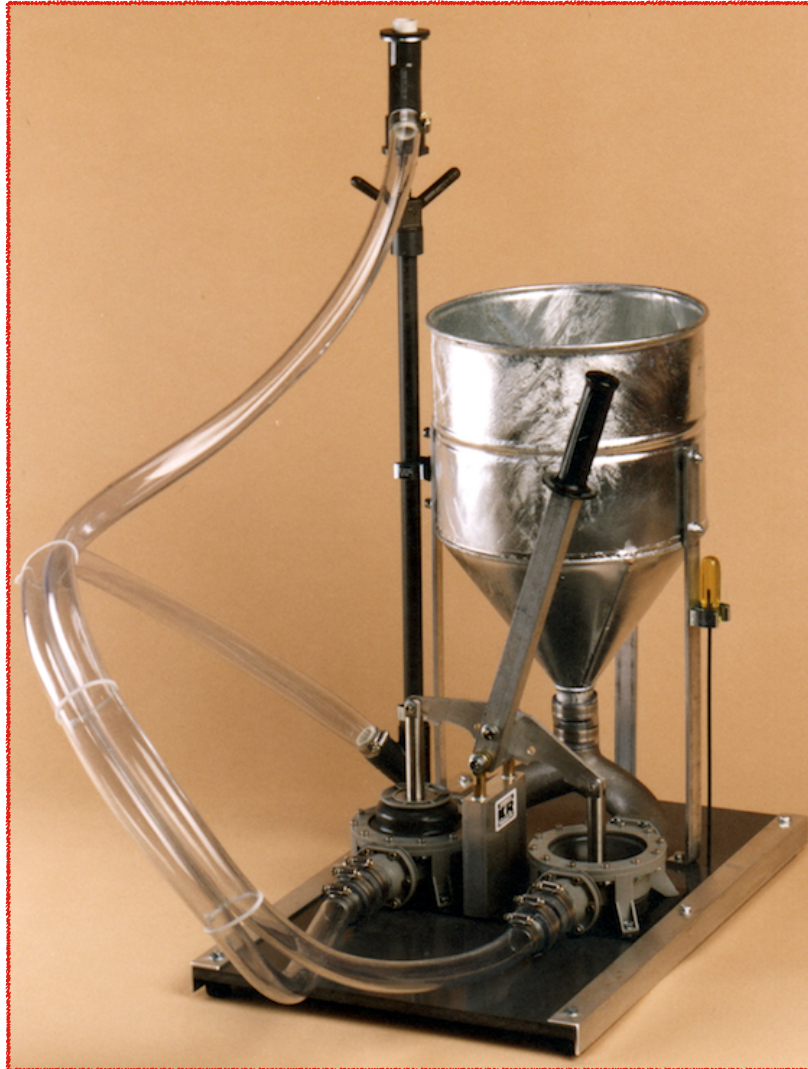

- Use with GP-6 Manual

GROUT PUMP GP-7



Please use with GP-6 Manual

DESCRIPTION OF PRODUCT

The GP-7 grout pump is a modified version of our GP-6 model. The outlet manifold (see item #6) has been replaced with two outlet flanges (p/n 5019-16). This change allows grout to flow through two separate 1" ID placement hoses attached to the adjustable hose support assembly. Now you can fill both sides of the door frame simultaneously.

Using existing holes in the frame (or creating two 1" minimum diameter holes on opposite sides) allows attachment of the twin hose support assembly. Moving the vertical handle operates both diaphragm pumps.

GP-7 GROUT PUMP

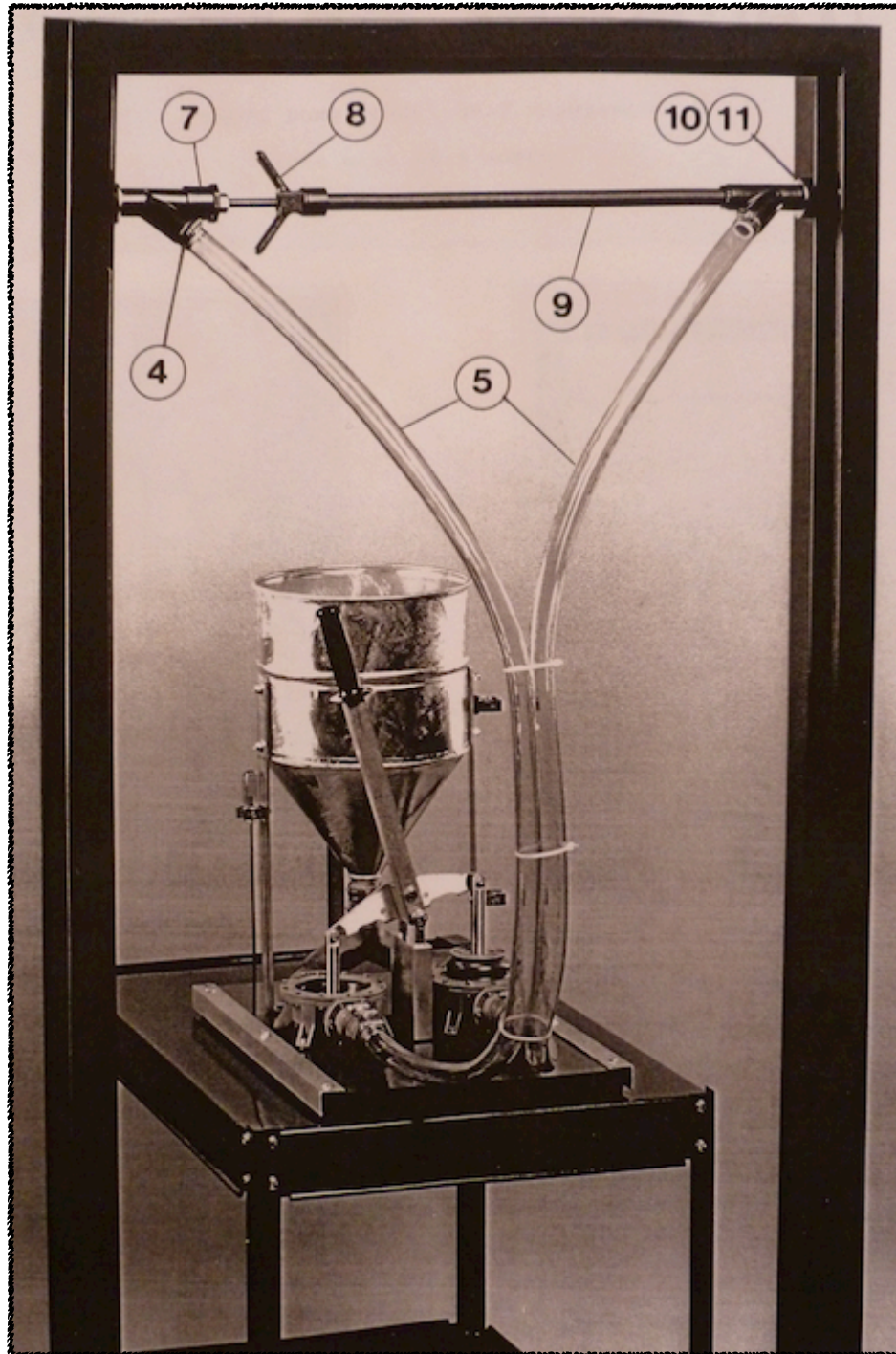

APPLICATIONS

Our model GP-7 Grout Pump is the perfect tool for filling hollow metal door frames. Now you can fill both sides of the frame at the same time. Using existing holes in the frame (or creating two 1" minimum diameter holes on opposite sides) allows attachment of the twin hose support assembly. Moving the vertical handle operates two diaphragm pumps simultaneously.

SPECIFICATIONS

Model	GP-7 Grout Pump
Pump Type	Twin Diaphragm, Self-Priming
Power Source	Hand Operated
*Output Capacity	5 gallons per minute
Output Pressure	Zero to 15 psi
Hopper Capacity	.62 cubic foot (4.6 gallons)
Hose Support Assembly	Adjust to fit 34" to 48" doors
Placement Hose Size	1 ½" ID by 60" long, Clear Vinyl
Discharge Head	10 foot Vertical Lift
Dimensions	16 ½" x 25" x 24" high
Net Weight	35 pound, including hose

OPTIONS

Hose Support Assembly to fit wider doorways is available.

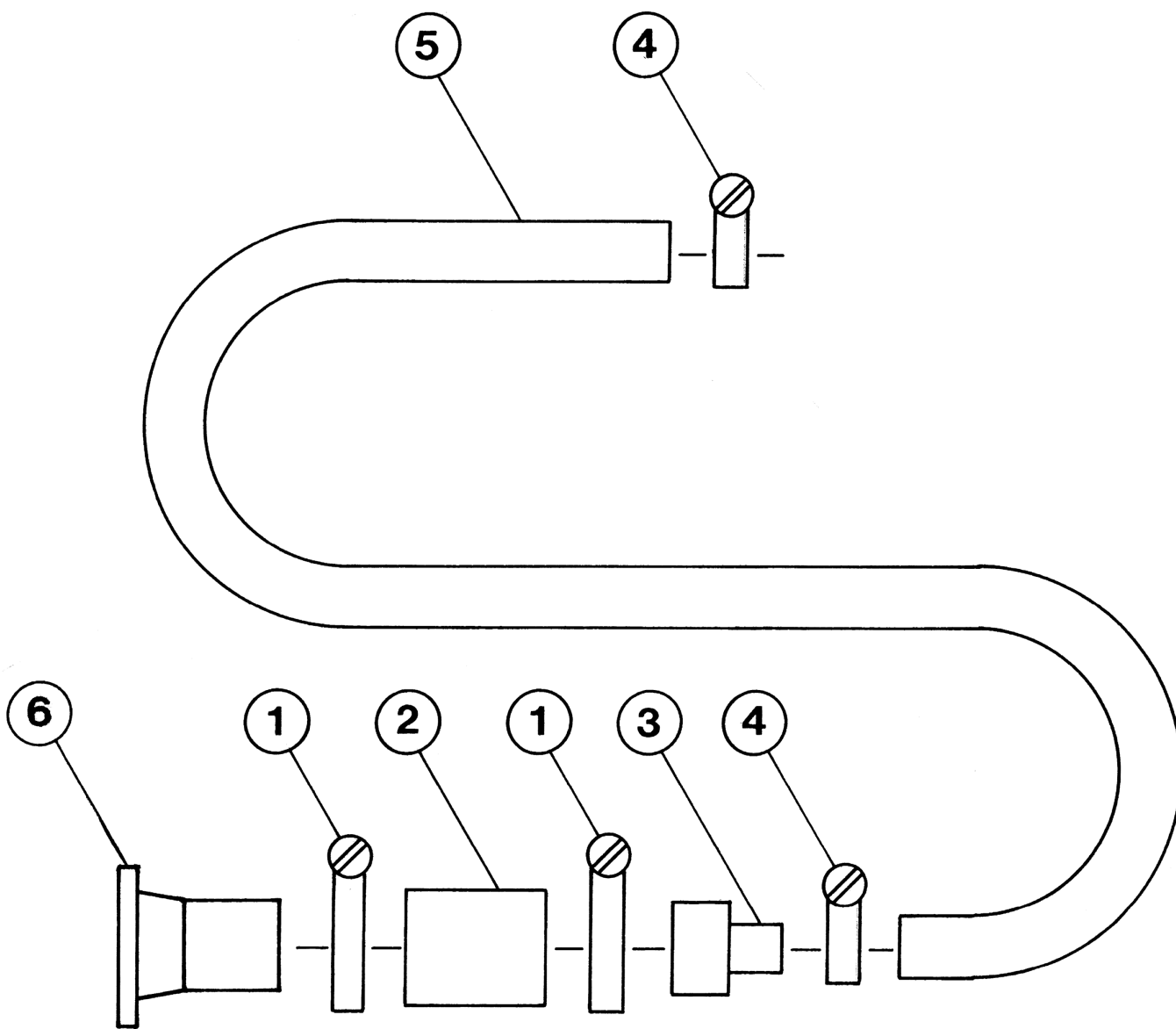

PARTS LIST (specific to GP-7)

<u>Item</u>	<u>Qty</u>	<u>Part Number</u>	<u>Description</u>
1	4	2178	Hose Clamp, #24
2	2	5022-0250	Sleeve
3	2	5076	Aluminum Adapter
4	4	2175	Hose Clamp, #12
5	2	5078-7200	Hose, 1" ID x 72" long
6	2	5019-16	Outlet Flange
7	1	5222	Hose Support w/rod (34" to 48" door frame)
7	1	5222-1	Hose Support w/rod (48" to 60" door frame)
7	1	5222-2	Hose Support w/rod (60" to 72" door frame)
8	1	5225	Wing Nut
9	1	5221	Hose Support w/tube
10	2	5224	Backup Washer
11	2	5223	Rubber Gasket

DESCRIPTION OF PRODUCT

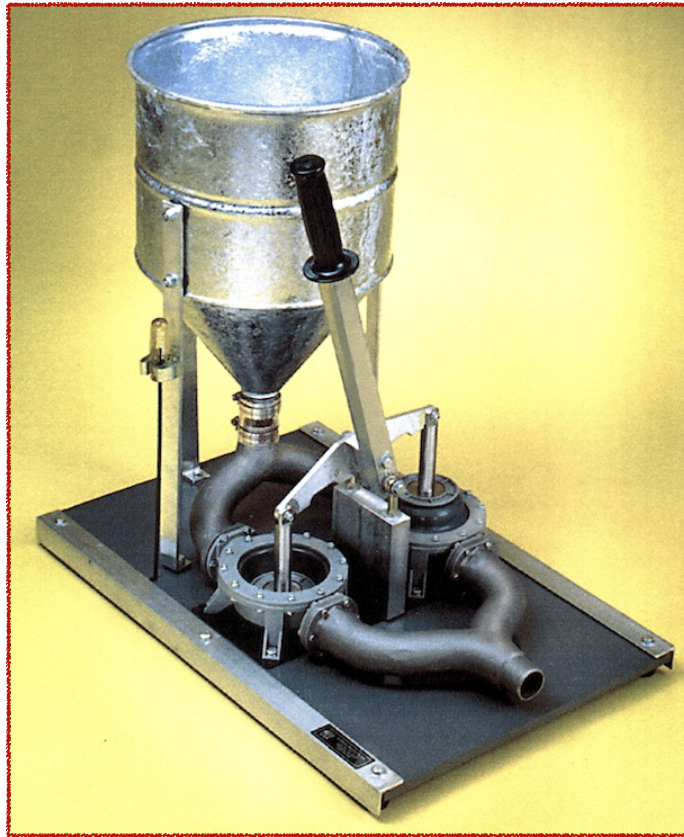

GROUT PUMP MODEL GP-6

The Kenrich model GP-6 is a hand operated twin diaphragm pump. It is designed to pump most types of water based grouts (not chemical based epoxy grouts). This model features two separate pumps connected by common inlet and outlet manifolds. Both pumps are powered by single pump handle.

The pumping action is achieved by moving the vertical pump handle back and forth (or up and down if the pump handle is in the optional horizontal position). When the pump handle is moved to the right, the grout mixture in the hopper is drawn into the left pump, while at the same time the grout mixture already in the right pump forced out into the placement hose where it is directed to the work area. When the handle is moved to the left, grout is drawn into the right pump while the grout in the left pump is forced out.

Limited Warranty

1) DURATION:

Three months (90 days) from date of purchase by the original purchaser.

2) WHO GIVES THIS WARRANTY (WARRANTOR):

Kenrich Products, Inc.
6853 #B N.E. 42nd Avenue
Portland, OR, 97218

3) WHO RECEIVES THIS WARRANTY (PURCHASER):

The original purchaser (other than for purposes of resale) of this Kenrich product.

4) WHAT IS COVERED UNDER THIS WARRANTY:

Defects in material and workmanship which occur within the duration of the warranty period.

5) WHAT IS NOT COVERED UNDER THIS WARRANTY:

A- IMPLIED WARRANTIES:, INCLUDING THOSE OF MERCHANTABILITY AND FITNESS FOR A PARTICULAR PURPOSE. Some states do not allow limitations on how long an implied warranty last, so the above limitations may not apply to you.

B- ANY INCIDENTAL, INDIRECT, OR CONSEQUENTIAL LOSS, DAMAGE OR EXPENSE THAT MAY RESULT FROM ANY DEFECT, FAILURE, MALFUNCTION OF A KENRICH PRODUCT. Some states do not allow exclusion limitation of incidental or consequential damages so the above limitations or exclusion may not apply to you.

C- Any failure that result from an accident, purchaser's abuse , neglect or failure to operate the product in accordance with the instructions provided in the owners manual supplied with the product.

D- Items or service that are normally required to maintain the product (i. e. diaphragms and flapper valves).

6) RESPONSIBILITIES OF WARRANTOR UNDER THIS WARRANTY:

Repair or replace, at Warrantor's option, products or components which have failed within the duration of the warranty period.

7) RESPONSIBILITIES OF PURCHASER UNDER THIS WARRANTY:

A) Deliver or ship the Kenrich product direct to Kenrich Products at address listed above. Freight cost, if any, must be borne by the purchaser.

B) Use reasonable care in the operation and maintenance of the product as described in the owners manual.

This Limited Warranty gives you specific legal rights and you may also have other rights which vary from State to State.

APPLICATIONS

Filling hollow concrete block walls
Grouting metal door and window frames in place
Hollow areas under machine bed plates
Filling voids
Placing grout anywhere that high pressure is not required

SPECIFICATIONS

Model	GP-6 Grout Pump
Pump Type	Twin Diaphragm, Self-Priming
Power Source	Hand Operated
*Output Capacity	11 gallons per minute
Output Pressure	Zero to 15 psi
Hopper Capacity	.62 cubic foot (4.6 gallons)
Placement Hose Size	1 ½ " ID by 60" long, Clear Vinyl
Discharge Head	10 foot Vertical Lift
Dimensions	16 ½ " x 25" x 24" high
Net Weight	32 pound, including hose

OPTIONS

Placement Hose	10 feet, 15 feet, and 20 feet
1 ½ " Hose Ends	Straight, 90° and 180° Elbows
Port Seal	Rubber, will fit 1 ½" Hose Ends
Hose Reducer Kits	¾" and 1" ID available

PERFORMANCE RECOMMENDATIONS

- 1) Always use the shortest length of placement hose as possible. The ideal is five feet long. When grouting metal door frames, place the pump on a cart or platform. This raises the pump handle to a better working height and allows the use of the standard five foot long placement hose.
- 2) Always use the largest diameter hose that access will allow. The ideal size is 1 ½" inside diameter. Never use a "**rubber based**" hose.
- 3) If limited access requires that you must use a hose reducer kit, (either ¾" or 1" inside diameter), remember that this reduction in hose size requires that the operator must cycle the pump at a much slower rate.
Note: **Never force the pump handle.**
- 4) It is always recommended that a quality pre-packaged grout to used. These products usually contain additives to help the grout pump and flow easier.
- 5) If you are mixing your own grout (sand/cement/water), the mixture will usually require additional cement in order to keep the sand in suspension. When pumping "home made" grout, extra time will be required to find the exact proportions of sand/cement/water to achieve a pumpable mixture.

OPERATION INSTRUCTIONS

- 1) Place grout in a suitable container and mix per manufacturers instructions. Pour the mixed grout mixture into hopper. Though usually not required, some grouts are easier to start pumping if the pump is first primed with a cement/ water slurry.
- 2) Move the vertical handle back and forth (or up and down if the handle has been installed in optional horizontal position) to draw the grout mixture from the hopper through the pumps and out the clear placement hose to the work area. CAUTION: VERY MINIMAL PUMP PRESSURE IS REQUIRED TO FILL VOIDS WITH GROUT.
Note: **Never force the pump handle.**
- 3) Be sure the work area begin filled is vented to allow any trapper air to escape.
- 4) Do not allow the grout to harden while inside or on the outside of the pump and related components. Clean immediately after use.
- 5) This pump is designed to pump most types of water based grouts. It is not to be used to pump chemical based epoxy grouts.

TROUBLESHOOTING GUIDE

PROBLEM	CAUSES	CORRECTIONS
Pump will not draw the grout mixture into pump.	Grout mixture is too thick.	Add water to grout mixture and/or prime the pump with a cement/water slurry.
	Hole in diaphragm(s).	Replace diaphragm(s).
	Incorrect installation or worn flapper valve(s).	Check for correct installation and/or replace damaged valves.
<hr/>		
Pumps water OK but will not pump grout mixture.	Grout mixture is too thick.	Add water to grout mixture and/or prime the pump with a cement/water slurry.
	Aggregate size too large.	Use smaller aggregate and/or screen out larger pieces.
<hr/>		
Grout mixture leakage.	Loose screws that attach clamp ring, inlet & outlet manifold to pump bodies.	Check and tighten screws as necessary.
	Cracked pump body.	Check and replace as required.
	Hole in diaphragm(s).	Replace diaphragm(s).
	Loose hose clamp(s).	Tighten hose clamp(s).

CLEANING & MAINTENANCE INSTRUCTIONS

- 1) Keep all interior and exterior surfaces of your Kenrich grout pump clean.
- 2) Immediately after use, flush the inside of the pump by filling the hopper with clean water while at the same time operating the pump. Continue until the water discharged through the placement hose is clear.
- 3) Rinse off all exterior surfaces with clean water until clean.
- 4) To prevent air and/or grout leakage, periodically check all pump screws and hose clamps for tightness. Always tighten screws evenly.
- 5) Be sure that any water trapped in the pump is drained out before winter storage to prevent damage caused from freezing.

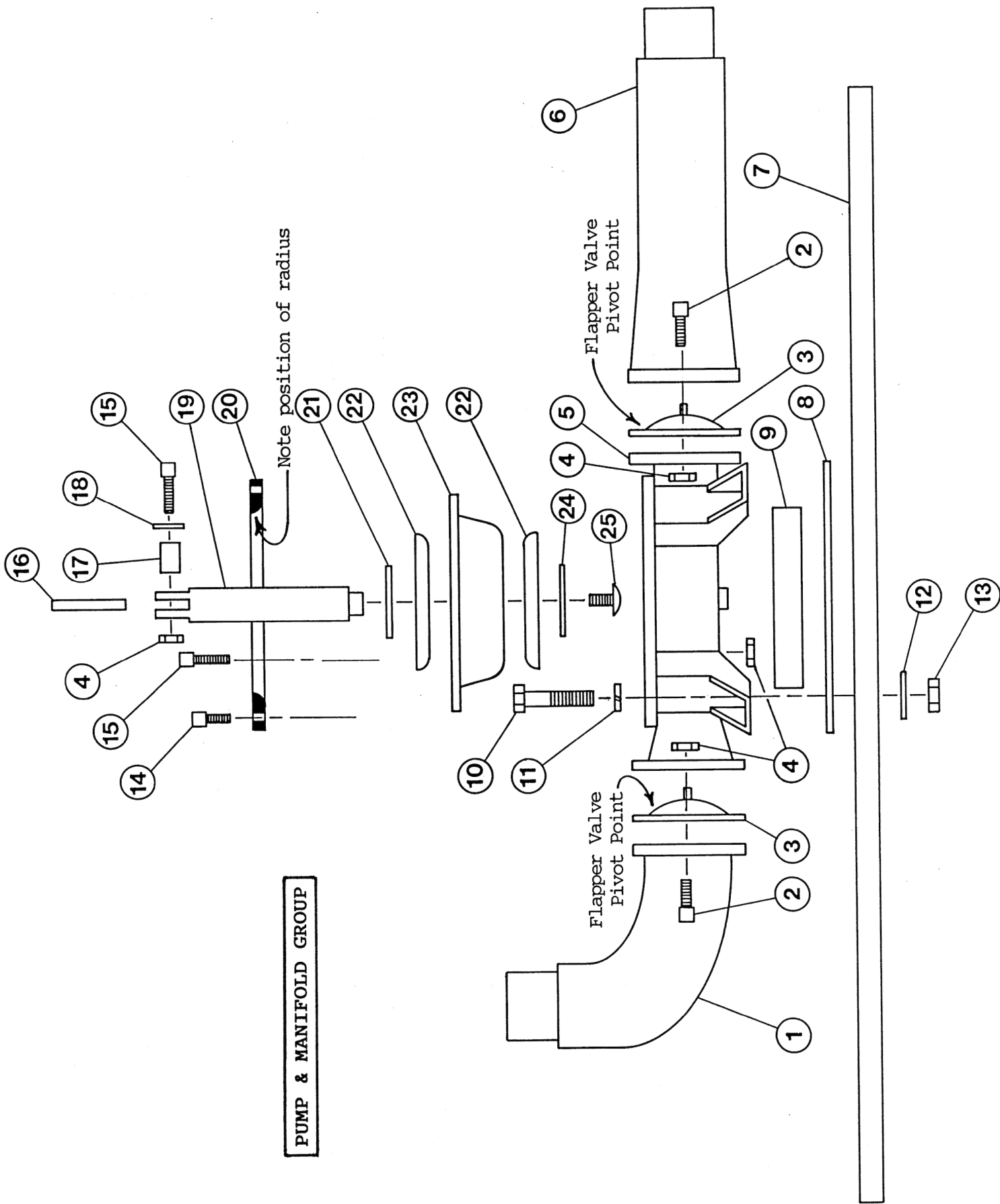

PUMP & MANIFOLD GROUP

SERVICE INSTRUCTIONS

- 1) Start with the diaphragm that is in the down position.
- 2) Using the tool supplied with the pump, remove 12 clamp ring retaining screws and lift up the clamp ring (item 20). Now move the pump handle to raise the diaphragm (item 23) from the pump body (item 5).
- 3) Pivot the clevis (item 19) outward to expose the bottom of the diaphragm (item 23) and remove the truss head retaining screw (item 25). Remove and discard the worn diaphragm.
- 4) Install new diaphragm and related parts as shown in illustration. Tighten truss head screw.
- 5) Swing the clevis down and lower diaphragm into pump body (item 5). Be careful to align rib on diaphragm into groove on pump body.
- 6) Position clamp ring, install 12 screws and tighten evenly.
- 7) Now replace second diaphragm using the same procedure as the first diaphragm.

FLAPPER VALVE REPLACEMENT

- 1) Loosen the hose clamp that attachment the hopper to the inlet manifold (item 1). Remove 3 capscrews that connect the hopper support legs to the baseboard. Lift off the hopper assembly and set aside.
- 2) Using the tool supplied with the pump, remove 24 screws (item 2) that attach the inlet and outlet manifolds (item 1 & item 6).
- 3) Remove and discard flapper valves (item 3). Then position the new flapper valves carefully noting direction and position of pivot point as shown on illustration. Align manifolds and install screws. Tighten evenly.
- 4) Install hopper assembly, support leg mounting capscrews and tighten hose clamp.
- 5) Replace tool in mounting clip on hopper support leg.

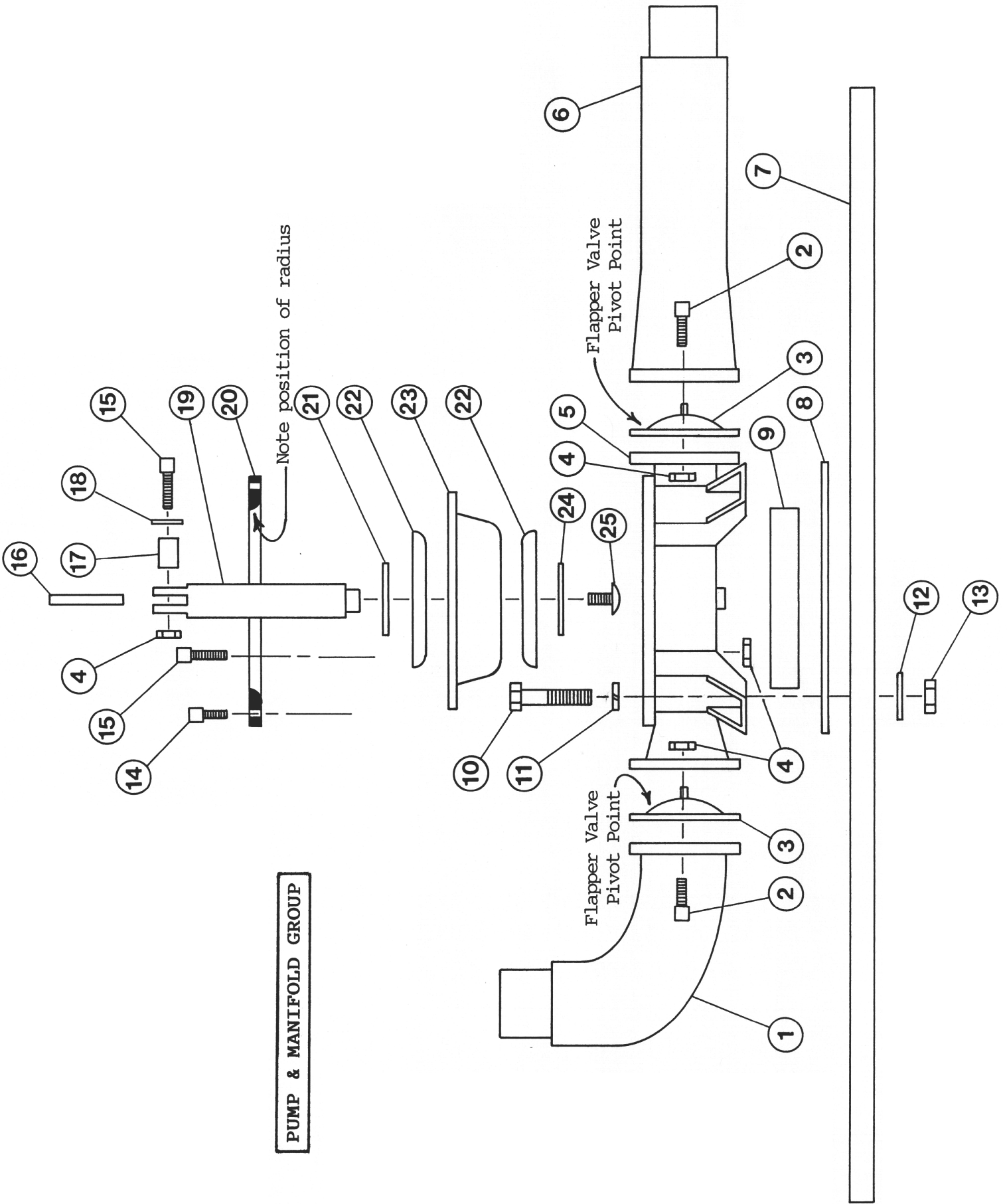

<u>Item</u>	<u>Qty</u>	<u>Part Number</u>	<u>Description</u>
1	1	5164	Inlet Manifold
2	24	1528-0062	Socket Head Machine Screw
3	4	5019-15	Flapper Valve
4	46	1453	Machine Hex Nut
5	2	5019-12	Pump Body
6	1	5165	Outlet Manifold
7	1	5159	Baseboard
8	1	5166	Spacer Plate
9	2	5157	PVC Spacer, 4" diameter
10	8	1000-0100	Hex Head Capscrew
11	8	1380	Lockwasher
12	8	1350	Flatwasher
13	8	1200	Hex Nut
14	4	1528-0050	Socket Head Machine Screw
15	22	1528-0075	Socket Head Machine Screw
16	1	5171	Rocker Arm
17	2	5019-6	Pivot Bushing, short
18	2	1490	SAE Flatwasher
19	2	5154	Clevis
20	2	5019-33	Clamp Ring
21	2	5019-22	Reinforce Washer, $\frac{1}{2}$ " hole
22	4	5019-21	Button
23	2	5019-9UR	Diaphragm
24	2	5019-29	Reinforce Washer, $\frac{1}{4}$ " hole
25	2	1050-0050	Truss Head Screw
NS	1	5019-34	Repair Kit (contains 2 diaphragms & 4 flapper valves)

Handle shown in standard vertical position.

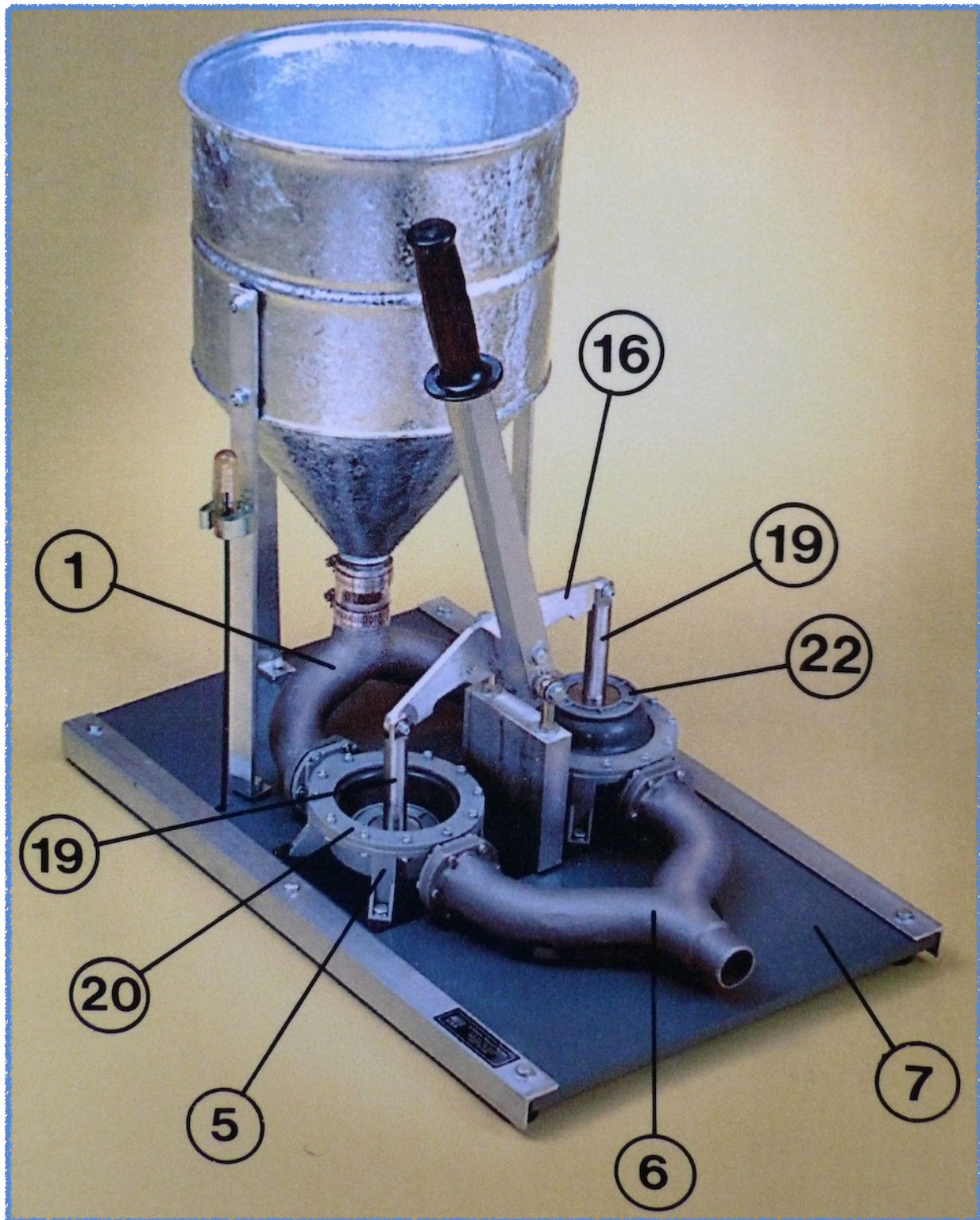

Handle shown in optional horizontal position.

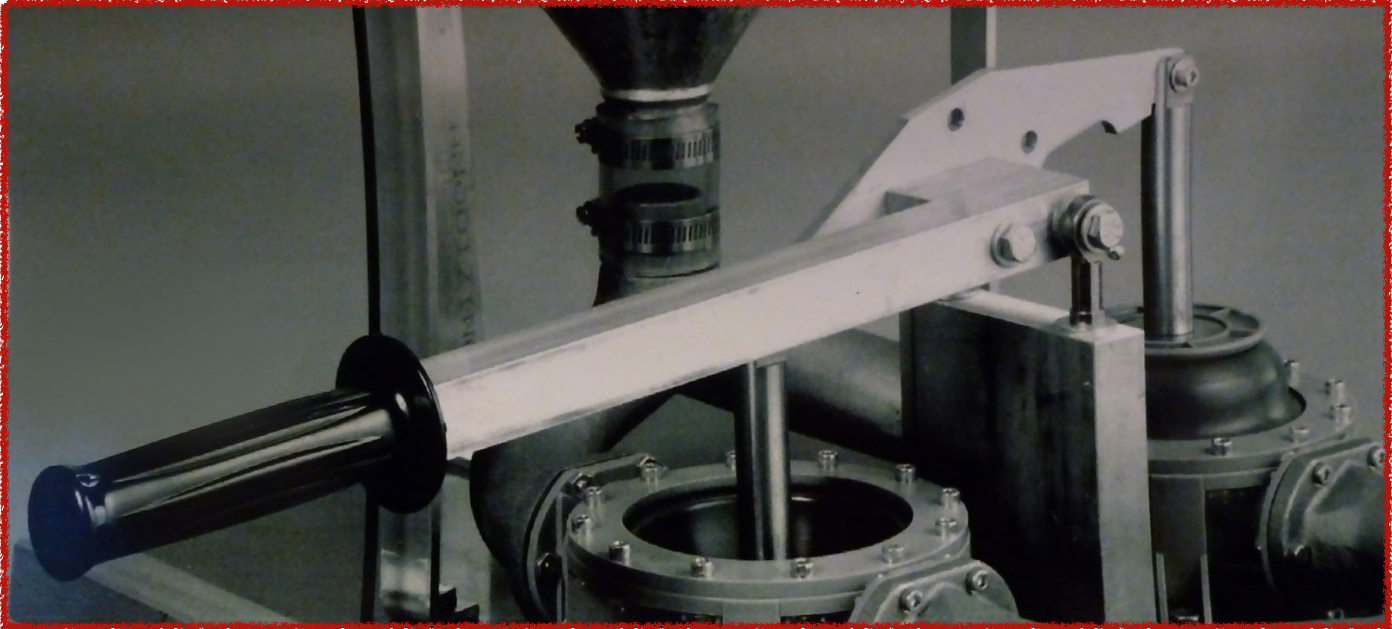

Item	Qty	Part Number	Description
1	2	1011-0600	Capscrew
2	2	1351	Flatwasher
3	1	5159	Baseboard
4	1	5166	Spacer Plate
5	1	5167	Support Block
6	8	1361	SAE Flatwasher
7	2	5168	Rod End
8	1	1001-0400	Capscrew
9	1	1001-0300	Capscrew
10	1	5171	Rocker Arm
11	2	1221	Esna Locknut
12	1	5169	Handle Weldment
13	1	5170	Vinyl Grip

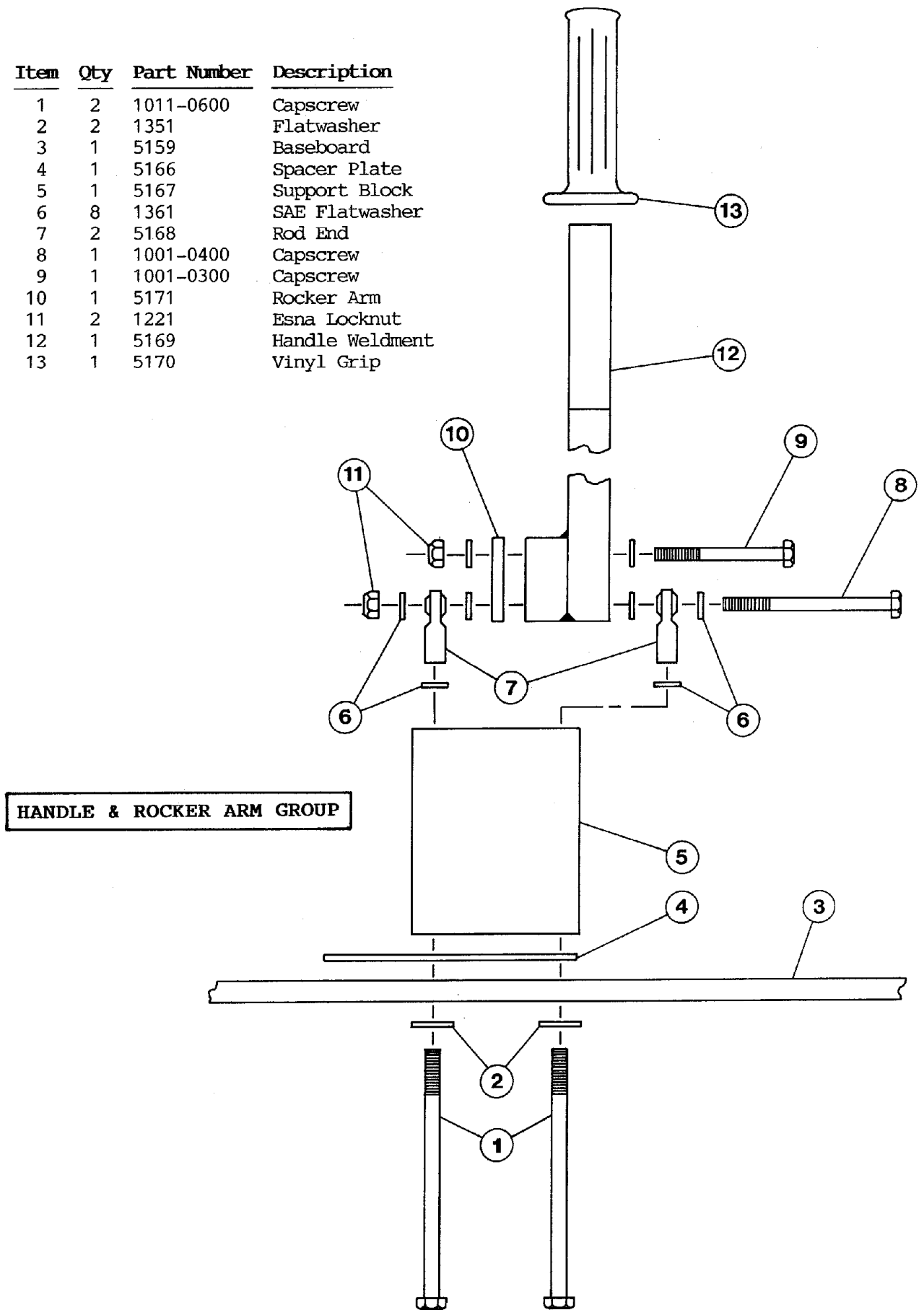

HOPPER & BASEBOARD GROUP

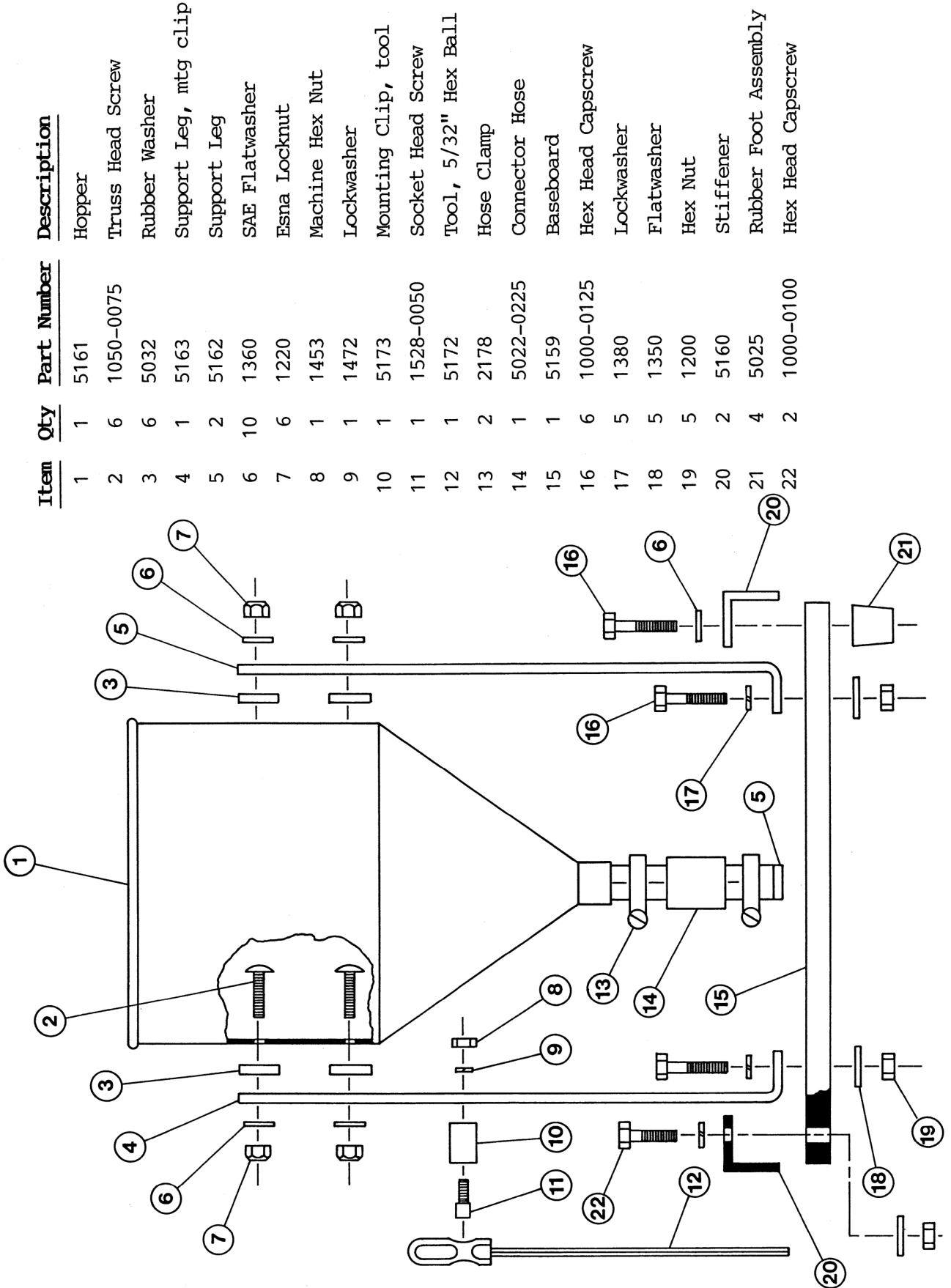

Item	Qty	Part Number	Description
1	1	5161	Hopper
2	6	1050-0075	Truss Head Screw
3	6	5032	Rubber Washer
4	1	5163	Support Leg, mtg clip
5	2	5162	Support Leg
6	10	1360	SAE Flatwasher
7	6	1220	Esna Locknut
8	1	1453	Machine Hex Nut
9	1	1472	Lockwasher
10	1	5173	Mounting Clip, tool
11	1	1528-0050	Socket Head Screw
12	1	5172	Tool, 5/32" Hex Ball
13	2	2178	Hose Clamp
14	1	5022-0225	Connector Hose
15	1	5159	Baseboard
16	6	1000-0125	Hex Head Capscrew
17	5	1380	Lockwasher
18	5	1350	Flatwasher
19	5	1200	Hex Nut
20	2	5160	Stiffener
21	4	5025	Rubber Foot Assembly
22	2	1000-0100	Hex Head Capscrew

1 1/2" HOSE ENDS & SEAL INSTALLATION

Straight, #5023

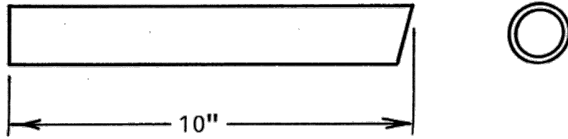

Seal Installation

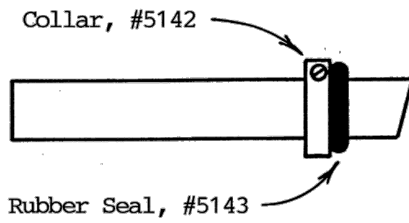

180° Elbow, #5140

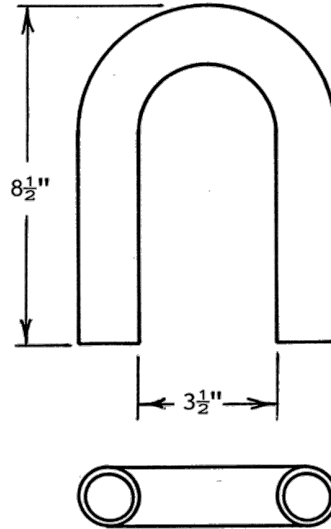

90° Elbow, #5139

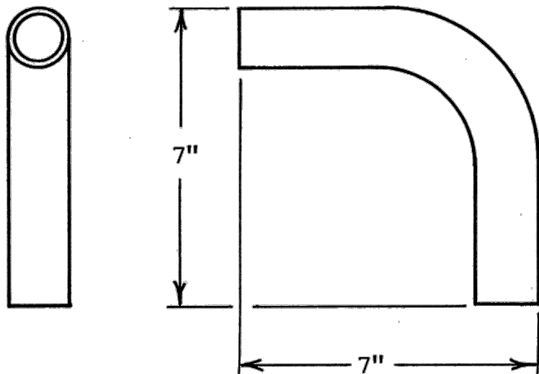

180° Elbow, Short Leg, #5141

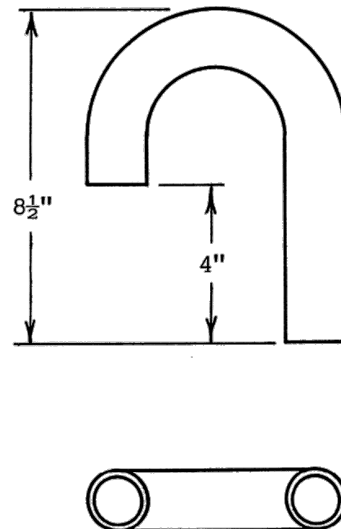

1 1/2" I.D. PLACEMENT HOSE

<u>Item</u>	<u>Qty</u>	<u>Part Number</u>	<u>Description</u>
1	2	2178	Hose Clamp
2	1	5022-5ft	Placement Hose
3	1	5022-10ft	Placement Hose
4	1	5022-15ft	Placement Hose
5	1	5022-20ft	Placement Hose
6	1	5023	Barrel

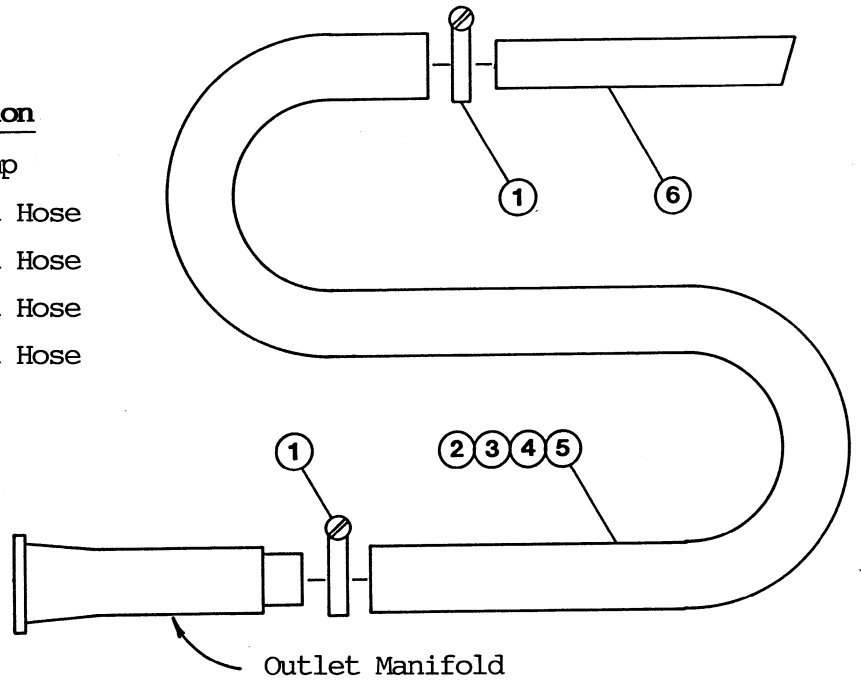

HOSE REDUCER KITS

<u>Item</u>	<u>Qty</u>	<u>3/4" Kit</u>	<u>1" Kit</u>	<u>Description</u>
All	1	5034	5083	Complete Hose Kit
1	2	2178	2178	Hose Clamp
2	1	5022-0250	5022-0250	Sleeve
3	1	5081	5076	Adapter
4	2	2174	2175	Hose Clamp
5	1	5079-6000	5078-6000	Placement Hose
6	1	5130	5131	Nozzle

