



KC85T

HIGH EFFICIENCY MULTICRYSTAL PHOTOVOLTAIC MODULE



HIGHLIGHTS OF KYOCERA PHOTOVOLTAIC MODULES

Kyocera's advanced cell processing technology and automated production facilities produce a highly efficient multicrystal photovoltaic module.

The conversion efficiency of the Kyocera solar cell is over 16%.

These cells are encapsulated between a tempered glass cover

and a pottant with back sheet to provide efficient protection from the severest environmental conditions.

The entire laminate is installed in an anodized aluminum frame to provide structural strength and ease of installation.

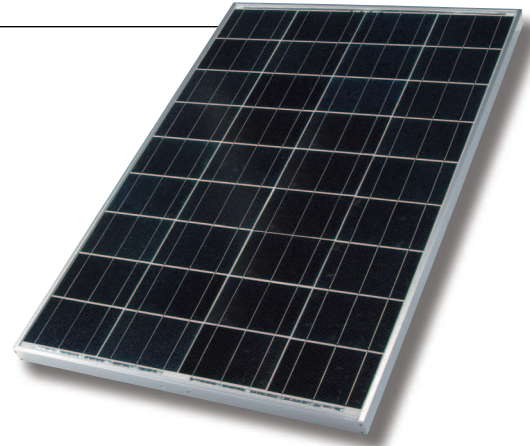

APPLICATIONS

- Microwave / Radio repeater stations
- Electrification of villages in remote areas
- Medical facilities in rural areas
- Power source for summer vacation homes
- Emergency communication systems
- Water quality and environmental data monitoring systems
- Navigation lighthouses, and ocean buoys
- Pumping systems for irrigation, rural water supplies and livestock watering
- Aviation obstruction lights
- Cathodic protection systems
- Desalination systems
- Recreational vehicles
- Railroad signals
- Sailboat charging systems
- etc.

QUALIFICATIONS

- **MODULE** : UL1703 certified
Hazardous Locations Class I, Div 2, Groups A, B, C and D
- **FACTORY** : ISO9001 and ISO 14001

QUALITY ASSURANCE

Kyocera multicrystal photovoltaic modules have passed the following tests.

- Thermal cycling test
- Thermal shock test
- Thermal / Freezing and high humidity cycling test
- Electrical isolation test
- Hail impact test
- Mechanical, wind and twist loading test
- Salt mist test
- Light and water-exposure test
- Field exposure test

LIMITED WARRANTY

※1 year limited warranty on material and workmanship

※20 years limited warranty on power output: For detail, please refer to "category IV" in Warranty issued by Kyocera

(Long term output warranty shall warrant if PV Module(s) exhibits power output of less than 90% of the original minimum rated power specified at the time of sale within 10 years and less than 80% within 20 years after the date of sale to the Customer. The power output values shall be those measured under Kyocera's standard measurement conditions. Regarding the warranty conditions in detail, please refer to Warranty issued by Kyocera)

ELECTRICAL CHARACTERISTICS

Current-Voltage characteristics of Photovoltaic Module KC85T at various cell temperatures

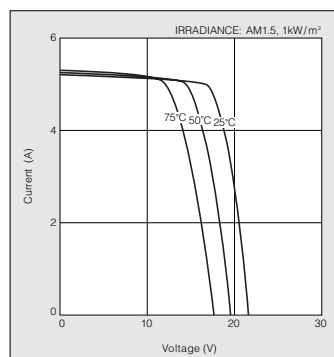

Current-Voltage characteristics of Photovoltaic Module KC85T at various irradiance levels

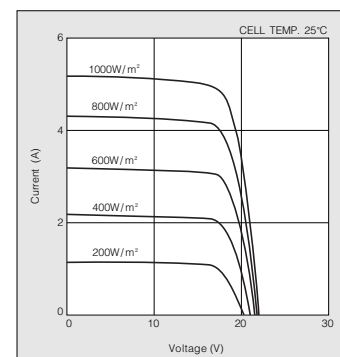

MODEL
KC85T

Physical Specifications

Unit : mm (in.)

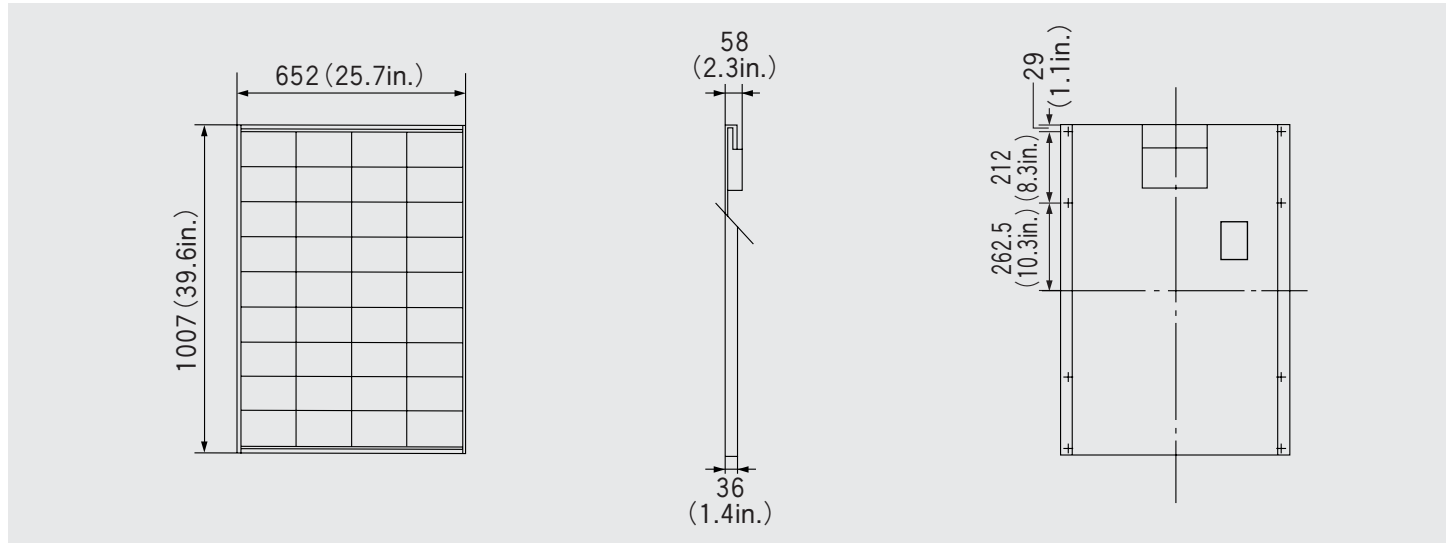

Specifications

Electrical Performance under Standard Test Conditions (*STC)

Maximum Power (Pmax)	87W (+10%/−5%)
Maximum Power Voltage (Vmpp)	17.4V
Maximum Power Current (Impp)	5.02A
Open Circuit Voltage (Voc)	21.7V
Short Circuit Current (Isc)	5.34A
Max System Voltage	600V
Temperature Coefficient of Voc	−8.21×10 ^{−2} V/°C
Temperature Coefficient of Isc	2.12×10 ^{−3} A/°C

*STC : Irradiance 1000W/m², AM1.5 spectrum, module temperature 25°C

Electrical Performance at 800W/m², NOCT, AM1.5

Maximum Power (Pmax)	62W
Maximum Power Voltage (Vmpp)	15.3V
Maximum Power Current (Impp)	4.06A
Open Circuit Voltage (Voc)	19.7V
Short Circuit Current (Isc)	4.31A

NOCT (Nominal Operating Cell Temperature) : 47°C

Cells

Number per Module	36
-------------------	----

Module Characteristics

Length × Width × Depth	1007mm(39.6in)×652mm(25.7in)×58mm(2.3in)
Weight	8.3kg(18.3lbs.)

Junction Box Characteristics

Length × Width × Depth	170.6mm(6.7in)×191.6mm(7.5in)×51.5mm(2.0in)
IP Code	IP65

Reduction of Efficiency under Low Irradiance

Reduction	6.1%
-----------	------

Reduction of efficiency from an irradiance of 1000W/m² to 200W/m² (module temperature 25°C)

Please contact our office for further information



KYOCERA Corporation

KYOCERA Corporation Headquarters

CORPORATE SOLAR ENERGY DIVISION
6 Takeda Tobadono-cho
Fushimi-ku, Kyoto
612-8501, Japan
TEL:(81)75-604-3476 FAX:(81)75-604-3475
<http://www.kyocera.com>

KYOCERA Solar, Inc.

7812 East Acoma Drive
Scottsdale, AZ 85260, USA
TEL:(1)480-948-8003 or (800)223-9580 FAX:(1)480-483-6431
<http://www.kyocerasolar.com>

KYOCERA Solar do Brasil Ltda.

Av. Guignard 661, Loja A
22790-200, Recreio dos Bandeirantes, Rio de Janeiro, Brazil
TEL:(55)21-2437-8525 FAX:(55)21-2437-2338
<http://www.kyocerasolar.com.br>

KYOCERA Solar Pty Ltd.

Level 3, 6-10 Talavera Road, North Ryde
N.S.W. 2113, Australia
TEL:(61)2-9870-3948 FAX:(61)2-9888-9588
<http://www.kyocerasolar.com.au/>

KYOCERA Fineceramics GmbH

Fritz Muller strasse 107, D-73730 Esslingen, Germany
TEL:(49)711-93934-917 FAX:(49)711-93934-950
<http://www.kyocerasolar.de/>

KYOCERA Asia Pacific Pte. Ltd.

298 Tiong Bahru Road, #13-03/05
Central Plaza, Singapore 168730
TEL:(65)6271-0500 FAX:(65)6271-0600

KYOCERA Asia Pacific Ltd.

Room 801-802, Tower 1 South Seas Centre, 75 Mody Road,
Tsimshatsui East, Kowloon, Hong Kong
TEL:(852)2-7237183 FAX:(852)2-7244501

KYOCERA Asia Pacific Ltd. Taipei Office

10 Fl., No.66, Nanking West Road, Taipei, Taiwan
TEL:(886)2-2555-3609 FAX:(886)2-2559-4131

KYOCERA(Tianjin) Sales & Trading Corporation

19F, Tower C HeQiao Building 8A GuangHua Rd.,
Chao Yang District, Beijing 100026, China
TEL:(86)10-6583-2270 FAX:(86)10-6583-2250