

Precast Concrete Insulated Sandwich Wall Panels

Technical Brochure

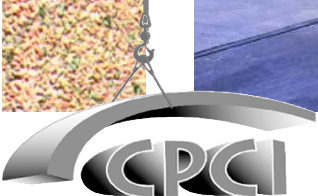

Canadian Precast/Prestressed Concrete Institute

Precast Concrete Insulated Sandwich Wall Panels



Insulated precast concrete panels provide functional and aesthetic value for exterior wall systems. Insulated precast sandwich wall panels consist of two reinforced or prestressed concrete wythes with a continuous layer of rigid insulation sandwiched between.

Precast insulated sandwich wall panels are available in a wide range of widths, lengths, thickness and exterior finishes. Standard modular panels provide speed and economy. Custom panels can be produced for a variety of special applications. Insulated sandwich wall panels offer many benefits because of their unique construction.

Energy Efficient

- Precast insulated sandwich panels have superior insulating properties - the type and thickness of rigid insulation contained in sandwich panels can vary with the RSI-value requirements for each building.
- The thickness of the insulation will be determined by the thermal characteristics of the material and the design temperatures of the structure.
- A minimum thickness of 25 mm is recommended with no limitation on maximum thickness.
- Insulation values are available from R5 to R20 or greater to suit project requirements.
- The insulation is installed under controlled factory conditions and is well protected by the concrete.
- The panel's high thermal mass is unmatched by any other material.
- Consult CPCI members for standard or custom insulation configurations.

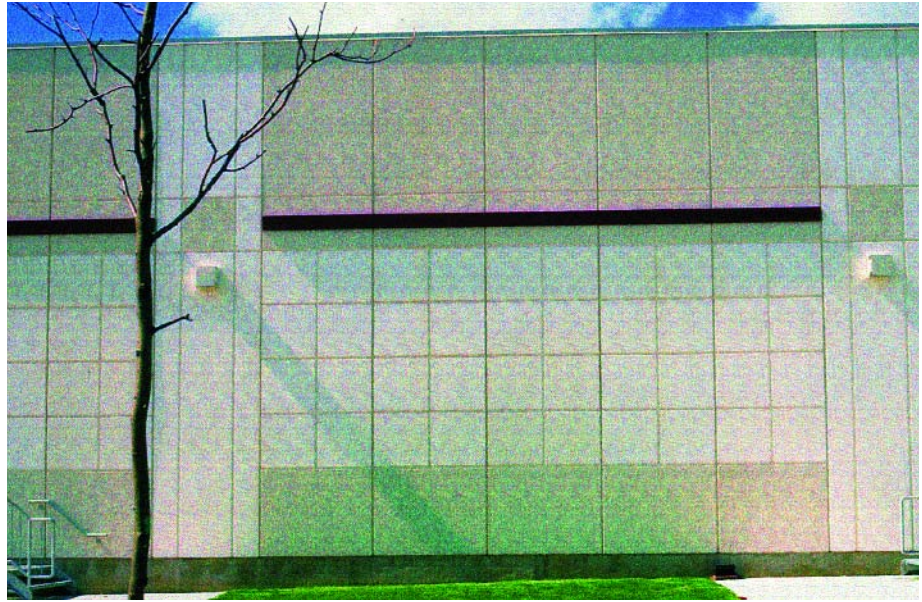

Long Life

- Durable precast concrete construction comes with a variety of pleasing aesthetic appearances.
- Minimum concrete strength is 35 MPa.
- Low maintenance means savings over the entire life of a building.
- The rigid insulation remains in place over time. The solid precast sandwich panel exterior and interior wythes prevent settling or shifting that could reduce thermal efficiency ensuring no delays due to bad weather.



Economical

- Panels are plant-produced in standard designs under controlled factory conditions.
- Panels have attractive exterior surfaces and smooth hard interior surfaces (ready for paint).
- Precast insulated panels are an inexpensive, strong, durable, energy efficient, fire resistant cladding system.
- Panels allow for easy expansion or adaptation to new uses during the life of a building.



Fast Construction

- Fast erection allows the building shell to be enclosed quickly in all seasons - ensuring no delays due to bad weather.
- Panels can be erected at rates of up to 120 linear meters per day on concrete or steel frame buildings.
- Exterior walls for entire buildings can be installed in a day or days.
- Panels are usually designed to span from the foundation wall to the roof without intermediate supports.
- Panels can be used for both load bearing and non-load bearing applications.

Attractive Finishes

- Designers have the flexibility to select from a wide range of shapes, finishes, colours and sizes.
- Exterior finishes can be smooth, ribbed or textured.
- Prefinished smooth concrete interior wall surfaces resist everyday wear and tear damage.
- Prefinished smooth concrete interior wall surfaces meet the requirements for food processing and other clean occupancies.

When speed, economy and appearance are important, precast insulated sandwich wall panels are the solution of choice.





Structural Integrity

- Single storey panels can usually be designed to span between the foundation and roof beams without intermediate supports.
- Load bearing panels can eliminate the need for beams and columns along exterior walls.
- Precast sandwich panels can accommodate a wide variety of loads, including wind, seismic and equipment.

Fire Resistant

- Precast concrete has superior fire resistance. The rigid insulation is protected between two layers of precast concrete.
- Sandwich panels can provide for 1 to 3 hour fire resistance when required.
- Precast wall panels have inherent fire containment characteristics.
- Precast concrete adds safety and security. This should improve insurance rates and mortgage approvals.
- Consult CPCI members for specific fire rating requirements.





Acoustic/Vibration Control

- High sound-attenuating properties result from the two layers of concrete combined with the insulating core.
- Enhanced noise containment keeps unwanted noise out and inside noise from disturbing the neighbours.
- Precast sandwich panels are ideal for residential buildings, schools, colleges, high-tech labs, research departments and related specialized environments.
- Consult CPCI members for STC ratings of specific panel design/insulation thickness combinations.

Modular Insulated Sandwich Wall Panels

- Modular panels are mass-produced in standard widths on long-line casting beds under controlled factory conditions.
- A layer of continuous insulation separates the inner and outer concrete wythes.
- Composite panels have the inner and outer wythes interconnected through the insulation by rigid ties.
- Composite panels are usually longitudinally prestressed.
- With attractive sculptured exterior surfaces and steel-formed interior finishes, modular panels provide a strong, durable, energy-efficient, fire resistant cladding system.
- Consult CPCI members for standard sizes, exterior finish patterns and colours.

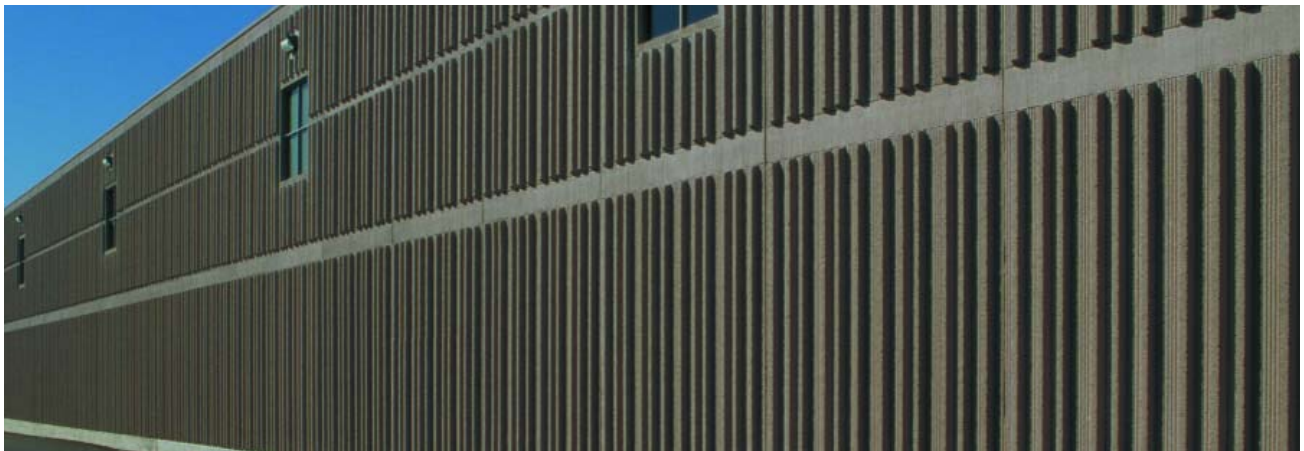



Custom Insulated Sandwich Wall Panels

- Custom sandwich panels are usually produced face down in custom forms and are available in a greater variety of exterior finishes and panel sizes.
- A layer of continuous insulation separates the inner and outer concrete wythes.
- The interior finish is smooth steel trowel (suitable for painting).
- Panels are generally designed as non-composite, in which the inner structural wythe is thicker and stiffer and transfers vertical and lateral loads to the building's structural framework.
- The inner structural wythe supports the weight and loads imposed on the exterior wythe through relatively flexible ties and/or hangers.
- Consult CPCI members for the full range of exterior colours, textures and finish patterns.

Panel Sizes

- The size of insulated panels will be primarily determined by architectural design considerations.
- The maximum panel dimensions and weight should be determined based on handling, transportation and installation requirements. Consult CPCI members.
- The maximum dimension of composite precast concrete insulated panels will be in the order of $L = 48t$, where L = the maximum panel dimension and t = overall panel thickness, excluding any ribs.



- The maximum dimension of non-composite precast concrete insulated panels will be in the order of $L = 48c$, where L = the maximum panel dimension and c = overall panel thickness, minus the thickness of the insulation.
- Panel thickness can vary from 170 to 300 mm depending on design considerations and insulation thickness.
- Consult the CPCI Design Manual and CPCI members for specific design information.

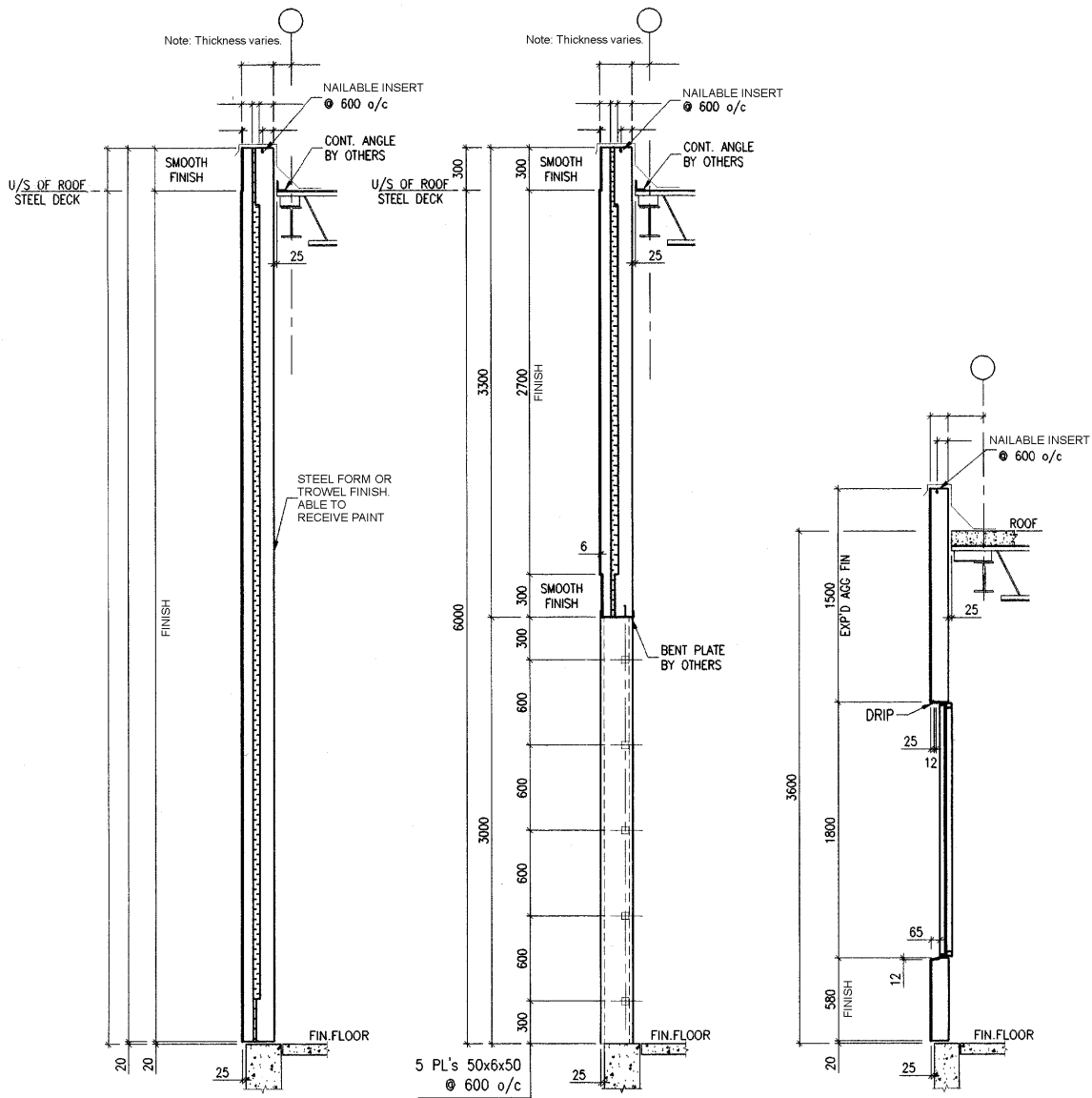

Section 1
Full Height Wall

Section 2
Truck Door

Section 3
Office Window

Typical Wall Sections

Note: Dimensions shown are for descriptive purpose only. Consult CPCI members for specific dimensions.

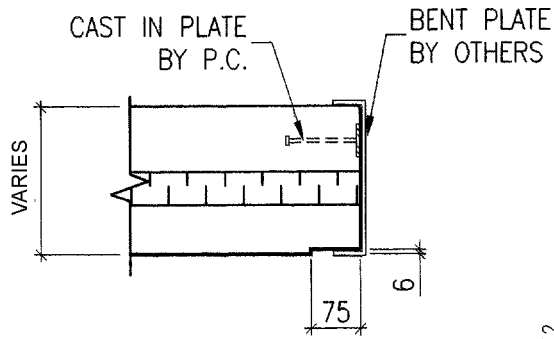

Plan Detail

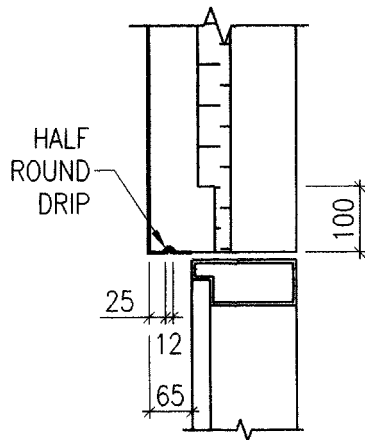

Head Detail @ Man Door

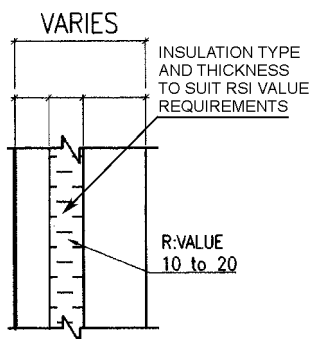

Typical Wall Sections

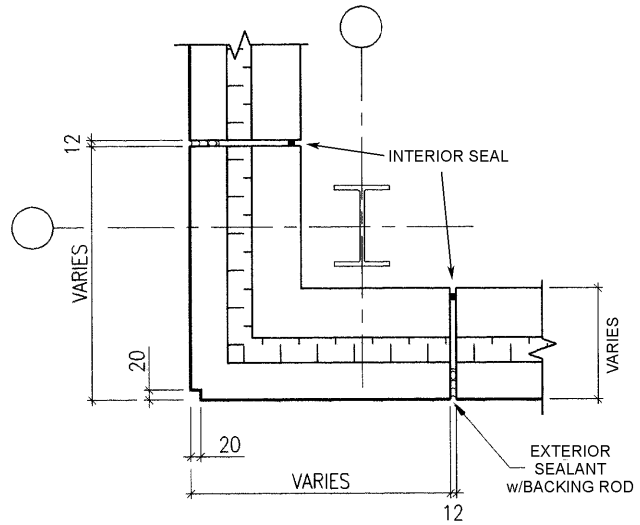

Plan Detail @ Corner

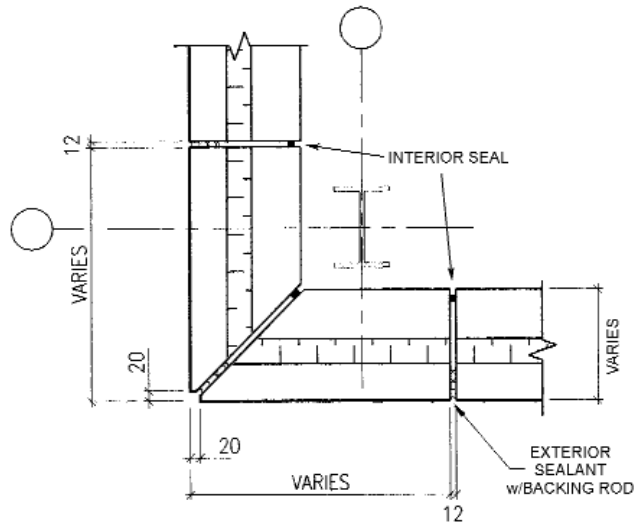

Mitred Detail

Insulation and panel thickness varies as required to meet insulated wall performance.

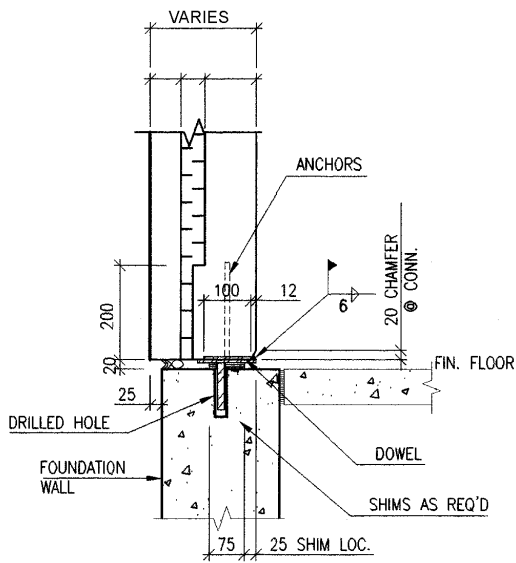

Section
Bottom Lateral
(Connection D-1)

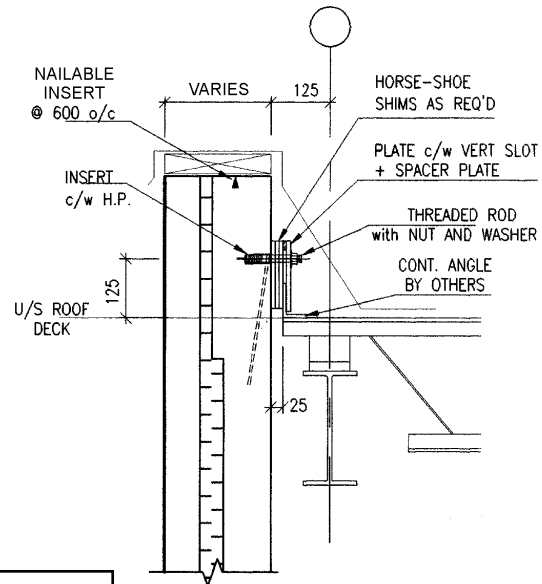

Section
Top Lateral
(Connection D-2)

Note: All connections shown are for concept design only.

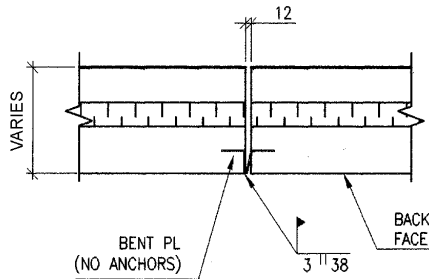

Plan Detail
Mid-Height Lateral
(Connection D-3)

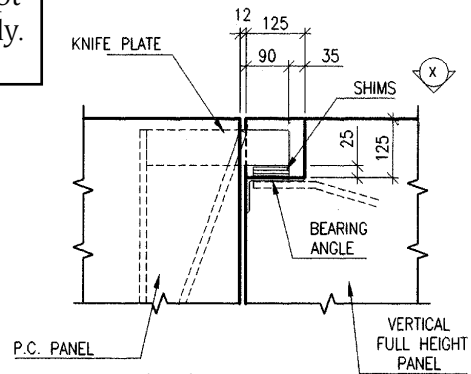

Back Elevation
Load Bearing @ O.H. Door
(Connection D-5)

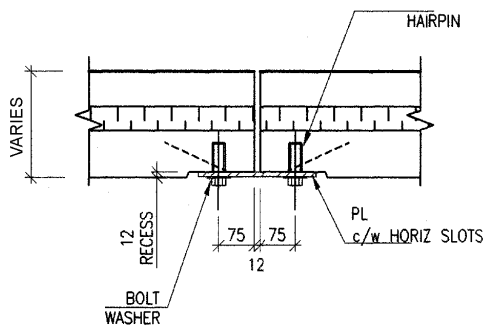

Plan Detail
Panel to Panel Lateral
(Connection D-4)

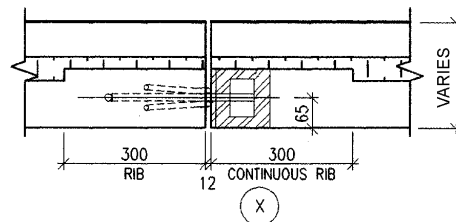

Plan Detail
Load Bearing @ O.H. Door
(Connection D-5)

Specification

Section 03450 - Insulated Wall Panels

1.0 General

1.1 Description

- .1 The General conditions of the Contract and Supplementary General Conditions apply to this Division, except as qualified herein and/or excluded.
- .2 Refer to drawings and specifications.

1.2 Work Included

- .1 Design, supply, delivery and installation of:
 - .1 Precast concrete insulated wall panels.
 - .2 Field sealing of all precast concrete wall panels inside where accessible and outside between precast panels and between precast and foundation walls.
 - .3 Take delivery and cast into precast work boxes/inserts/openings required by other trades.

Spec Note: *Structural fabricator to provide approved shop drawings for precaster's reference.*

- .2 Supply information required for installation of bracing, supports, inserts and similar accessories required for work under this contract supplied and installed by others.

1.3 Related Work

- .1 Section 03300 - Cast-in-Place Concrete
- .2 Section 03300 - Cast-in-Place Concrete: Setting only of inserts or anchors unless otherwise noted on Structural Drawings
- .3 Section 07200 - Thermal Protection
- .4 Section 07900 - Joint Sealers
- .5 Section 08400 - Entrances & Storefronts
- .6 Section 08500 - Windows
- .7 Section 07800 - Fire and Smoke Protection
- .8 Supply and installation of:
 - .1 Hollow metal frames: Section 08100 - Metal Doors & Frames.
 - .2 Structural steel framing except around door openings: Section 05100 - Structural Metal Framing.
 - .3 Field caulking between precast concrete and masonry.

Spec Note: *Latest Standards are listed. Specifier to update specification to latest CSA Standard.*

1.4 Reference Standards

- .1 CSA A23.1-00, Concrete Materials and Methods of Concrete Construction
- .2 CSA A23.2-00, Methods of Test for Concrete
- .3 CSA A23.3-94, Design of Concrete Structures
- .4 CSA A23.4-00, Precast Concrete-Materials and Construction
- .5 CSA A251-00, Qualification Code for Architectural and Structural Precast Concrete Products
- .6 CSA A266.4-M78, Guidelines for the Use of Admixtures in Concrete
- .7 CSA A266.5-M1981, Guidelines for the Use of Superplasticizing Admixtures in Concrete.
- .8 CSA A283-1980, Qualification Code for Concrete Testing Laboratories
- .9 CAN/CSA-G164-M92, Hot Dip Galvanizing of Irregularly Shaped Articles

Specification

continued...

- .10 CSA W186-M1997, Welding of Reinforcing Bars in Reinforced Concrete Construction
- .11 W47.1-97, Certification of Companies for Fusion Welding of Steel Structures

1.5 Qualifications of Manufacturer

- .1 Fabricate precast concrete elements certified by the Canadian Standards Association in the appropriate category(ies) according to CSA Standard A23.4-00 "Precast Concrete - Materials and Construction". The precast concrete manufacturer shall be certified in accordance with the CSA Certification Program for Architectural and Structural Precast Concrete prior to submitting a tender and must specifically verify as part of his tender that he is currently certified in the appropriate category(ies):
 - (A) Precast Concrete Products - Architectural

Spec Note: *Delete categories that are not applicable.*

- (I) Non-Prestressed or (II) Prestressed
- (B) Precast Concrete Products - Structural
 - (I) Non-Prestressed or (II) Prestressed
- (C) Precast Concrete Products - Speciality
 - (I) Non-Prestressed or (II) Prestressed

Only precast concrete elements fabricated by certified manufacturers are acceptable to the Owner. Certification must be maintained for the duration of the fabrication and erection for the project. Fabricate precast concrete elements in accordance with _____ (Provincial) Building Code requirements.

- .2 The insulated precast concrete manufacturer shall have a proven record and satisfactory experience in the design, manufacture and erection of insulated precast concrete facing units of the type specified. The company shall have adequate financing, equipment, plant and skilled personnel to detail, fabricate and erect the work of this Section as required by the Specification and Drawings. The size of the plant shall be adequate to maintain the required delivery schedule.

1.6 By-Laws and Codes

- .1 Conform with applicable requirements of _____ (Provincial) Building Code, National Building Code and local authorities having jurisdiction.
- .2 Design and provide reinforcement, anchors and supports as required by codes and to Consultant's approval. Submit relevant design data prepared by a registered structural engineer for approval if so requested by the Consultant.

1.7 Allowable Tolerances

- .1 Conform with requirements of CSA A23.4-Section 10
- .2 Refer to related Sections of this Specification and fabricate work to accommodate specified tolerances.

1.8 Source Quality Control

- .1 In addition to quality control, an independent inspection and testing company may be appointed by the Owner to verify compliance with this Specification.
- .2 Cooperate with Inspector to facilitate his work.
- .3 Cost of independent inspection to be paid by the owner.

Specification

continued...

1.9 Shop Drawings

Spec Note: *It is not the Precast Manufacturer's responsibility to confirm and correlate dimensions at the job site. Precast concrete is a prefabricated material. Site dimensioning would require the structure to be complete before fabrication could commence.*

- .1 Prepare and submit shop drawings in accordance with the General Conditions of the contract, CSA A23.4 and CSA A23.3, and as specified below. Submit in accordance with Section 01330.
- .2 Submit fully detailed and dimensioned drawings showing method of fastening and sealing. Indicate type of finish and other pertinent information on each shop drawing.
- .3 Show exact location of inserts and anchors required to be cast in precast units for interface elements.
- .4 Show the system of identifying units for erection purposes on shop drawings and apply a similar mark on units at time of manufacture.
- .5 Provide Shop Drawings to obtain approvals from the Authorities Having Jurisdiction prior to fabrication of the insulated precast panels.
- .6 Each drawing submitted shall bear stamp and signature of a registered professional engineer registered in [Canada] [Province of _____].

Spec Note: *See CSA A23.4-00 Re: Variation. Precast concrete industrial/commercial sandwich wall panels are often manufactured "face-up" and will have slight colour variations. Establish a series of samples to establish an acceptable colour range.*

1.10 Samples

- .1 Provide samples of insulated precast cladding for approval. Unless otherwise noted, the minimum sample size shall be 300 x 300 x 25 mm. Finish exposed face as described under "finishes" elsewhere in this Section. Make samples to obtain approval. All work shall match the approved production run panel colour range.

1.11 Warranty

- .1 Provide standard warranty with a duration of one (1) year in accordance with the General Conditions. Warranty shall be in writing and shall warrant materials and workmanship under this Section to be free from defects for the period stipulated.

1.12 Delivery, Storage and Protection

- .1 Accept full responsibility for delivery, handling and storage of units.
- .2 Deliver, handle and store precast units in a near vertical plane at all times, and by methods approved by the manufacturer. Do not permit units to contact earth or staining influences or to rest on corners.

1.13 Design

- .1 Requirements: Design and fabricate insulated panels, brackets and anchorage devices so that when installed they will:
 - .1 Compensate for allowable construction tolerances in structure to which they are secured.
 - .2 Tolerate structural deflection of span/360 due to live load and distortion of structure, without imposing load on panel assembly.

Specification

continued...

- .3 Adequately sustain themselves, and superimposed wind, snow loads, without exceeding deflection of span/360.
- .4 Permit no water infiltration into the building under design loads.
- .2 Design loads shall be as specified by the _____(Provincial) Building Code.
- .3 Panels to be non-composite or composite as required to meet unsupported span requirements.
- .4 Insulate panels to provide an R_____wall assembly.

2.0 Products

2.1 Materials

- .1 Cement, [grey cement][white cement][colouring material], aggregates, water admixture: to CSA A23.4 and CSA A23.1.

Spec Note:

Re 2.1.2: Due to the large variety of exposed aggregate finishes for precast concrete and the lack of standards, it is necessary to preselect finish, texture and colour in cooperation with CPCI members. Ensure that this is done before the specification is written and include the generic name of the selected aggregate, sizes of aggregate and the proportions of different colours and sizes. Precast concrete industrial/commercial sandwich wall panels are often manufactured "face-up" and will have slight colour variations. Establish a series of samples to establish an acceptable colour range.

- .2 Exposed aggregate [and special facing materials]: [quartz] [dolomite] [granite] [marble] [river stone] to match selected finish sample.
- .3 Use same brand and source of cement and aggregate for the entire project to maximize the uniformity of coloration and other mix characteristics.
- .4 Reinforcing steel: to CSA A23.4.
- .5 Forms: to CSA A23.4.
- .6 Hardware and miscellaneous materials: to CSA A23.4.
- .7 Anchors and supports: to CSA G40.21, Type [400W].

Spec Note:

Re 2.1.7: Type 400W is weldable structural grade steel having a yield strength of 400 MPa. Refer to CSA G40.21 for other grades and yield strengths available.

- .8 Welding materials: to CSA W47.1-97 and CSA W186-[M1997].
- .9 Steel primer: to CGSB 1-GP-40M.
- .10 Air entrainment admixture: to CSA A266.4.
- .11 Bearing pads: smooth, [high impact plastic] [steel].
- .12 Bearing pads: neoprene, [60] durometer hardness to ASTM D2240, and [17] MPa minimum tensile strength to ASTM D412, moulded to size or cut from moulded sheet.
- .13 Shims: [plastic] [steel].
- .14 Zinc-rich primer: to CGSB 1-GP-181M.
- .15 Surface retardant: to CSA A266.2.
- .16 Insulation: extruded polystyrene to CAN/CGSB - 51.20 - M87 Type 2 OR expanded polystyrene to CAN/CGSB-51.20, Type 1.

2.2 Concrete Mixes

- .1 Unless otherwise noted or specified, use concrete mix designed to produce a minimum of 35 MPa compressive cylinder strength at 28 days, with a maximum water/cement ratio to CSA A23.4.
- .2 Use white or grey cement in facing matrix.
- .3 Air Entrainment of Concrete Mix: Refer to CSA A23.4
- .4 Use of calcium chloride not permitted.

Specification

continued...

2.3 Reinforcement and Anchors

- .1 Add reinforcement in accordance with CSA W.186.70.
- .2 Paint anchors after fabrication with zinc rich primer. Touch up anchors with zinc rich primer after welding.
- .3 Reinforcing Steel: To CSA G30.16 or CSA G30.12.
- .4 If panels are prestressed, conform to CSA A23.3.

2.4 Fabrication

- .1 Production of insulated precast concrete wall panels, fabricate units to CSA A23.4.
- .2 Mark each precast unit to correspond to identification mark on shop drawings for location.
- .3 Mark each precast unit with date cast.
- .4 Ensure that surfaces to receive sealant are smooth and free of laitance to provide a suitable base for adhesion. Ensure that release agents do not deleteriously affect the sealing of the joints.
- .5 Cast panels in accurate rigid moulds designed to withstand high frequency vibration. Set reinforcing anchors and auxiliary items as shown on the drawings. Cast in anchors, blocking and inserts supplied by other Sections as required to accommodate their work.
- .6 Anchors, lifting hooks, shear bars, spacers and other inserts or fittings required shall be as recommended and/or designed by manufacturer for a complete and rigid installation. Each shall conform to requirements of local building By-Laws. Lift hooks shall be adequately sized to safely handle panels according to panel dimension and weight. Anchors/inserts shall be concealed where practical.
- .7 Burn off exposed lift cables paint and fill in if required.

2.5 Finish

Spec Note: *Select from 2.5.1 to 2.5.6 for the type of finish required and delete the remainder. Precast concrete industrial/commercial sandwich wall panels are often manufactured "face-up" and will have slight colour variations. Establish a series of samples to establish an acceptable colour range.*

- .1 Finish and colour of precast units to match sample in [Consultant's] office.
- .2 Fluted finish: achieve finish using trapezoidal form liners or other mechanical methods.
- .3 Smooth finish: as cast using smooth [plastic] [steel] [wood] form liners.
- .4 Exposed aggregate finish:
 - .1 Apply even coat of retardant to inside face of forms.
 - .2 Remove panels from forms after concrete hardens.
 - .3 Expose coarse aggregate by washing and brushing away surface mortar.
 - .4 Expose aggregate to depth required.
- .5 Sandblast finish: in order to expose aggregate face, sandblast surface to depth to match approved sample.

Spec Note: *Re 2.5.6: Specify other finishes, broomed, bushhammered rib, textured form material, as required.*

- .6 Interior panel finish to be smooth steel trowel or smooth form finish.

Specification

continued...

3.0 Execution

3.1 General

- .1 Erect precast work in accordance with CSA A23.4.

Spec Note:

It is not the Precast Manufacturer's responsibility to confirm and correlate dimensions at the job site. Precast concrete is a prefabricated material. Site dimensioning would require the structure to be complete before fabrication could commence.

- .2 Supply anchors for precast units required to be cast into the concrete frame to Contractor for installation. Provide such items in ample time to meet construction program. Supply layout drawings locating accurately the position of all cast in items to be installed by other Sections.
- .3 Structural Engineer to sign-off on building stability prior to precast erection.

3.2 Installation

- .1 Set precast concrete units, straight, level and square.
- .2 Non-cumulative Erection Tolerances as per CSA A23.4.
 - .1 Joint dimension.
 - .2 Joint taper.
 - .3 Edge alignment.
 - .4 Faces of adjacent panels.
 - .5 Bowed panels.
- .3 Fasten units in place as per approved connection detail shop drawings. Protect work from damage by weld splatter.
- .4 Clean field welds with wire brush and touch up with galvafruid paint or zinc rich primer.
- .5 Remove temporary shims and spacers from joints of non-load bearing panels after fastening but before sealant is applied.
- .6 Apply sealant and joint backing to exterior and interior joints to provide a complete weathertight installation in accordance with Section 07900. All exterior joints are to be vented.

3.3 Cleaning

- .1 If required, clean exposed face work by washing and brushing only, as precast is erected. Use approved masonry cleaner if washing and brushing fails to achieve required finish. Remove immediately materials which set up or harden. This section is not responsible for soiling or damage by others.

End of Section

Applications



Retail Centre



Cinema



Restaurant



Bus Transit Headquarters

Applications



Industrial Park



Retail Centre



Warehouse Complex



Retail Centre



Canadian Precast/Prestressed Concrete Institute

196 Bronson Avenue
Suite 100
Ottawa, Ontario
K1R 6H4

Telephone:
(613) 232-2619

Fax:
(613) 232-5139

Toll Free:
1-877-YES-CPCI
(1-877-937-2724)

E-mail:
info@cpci.ca

Web:
www.cpci.ca
www.precastsearch.com



DISCLAIMER: Substantial effort has been made to ensure that all data and information in this publication is accurate. CPCI cannot accept responsibility of any errors or oversights in the use of material or in the preparation of engineering plans. The designer must recognize that no design guide can substitute for experienced engineering judgment. This publication is intended for use by professional personnel competent to evaluate the significance and limitations of its contents and able to accept responsibility for the application of the material it contains. Users are encouraged to offer comments to CPCI on the content and suggestions for improvement. Questions concerning the source and derivation of any material in the design guide should be directed to CPCI.