

The Ultimate Deck Surface



Installation Manual

INTRODUCTION TO ADHERED DECTEC MEMBRANES

The DecTec System using, our internally reinforced deck waterproofing membranes, is adhered directly to the plywood or concrete substrate, which in turn has been fastened or otherwise secured to the structure by others. The Adhered System is described as follows:

Adhered System

The membrane is fully adhered, using either our approved WBA100 (water based) or SBA100 (solvent based) adhesives, to a smooth prepared, pre-secured substrate. All seams and/or terminations are then hot-air welded to produce a watertight seal.

DecTec membranes are ideal for adhering to decks due to the high quality internal reinforcements combined with the spread-coating manufacturing process we use. The reinforcements produce exceptional dimensional stability, closely matching that of the substrate. Our unique spread-coating process further adds to this stability since the liquid plastisol “paste” randomly flows around, and through, the reinforcement. The entire product is then passed through a high temperature oven to “gel” the plastisol and to fuse the components together. The finished DecTec membrane is stress-free and unable to delaminate under any conditions including “ponding” or standing water, which is defined as water causing the field membrane, or a properly welded seam, to be submerged for a length of time greater than 48 hours. DecTec membranes also withstand extreme weather conditions from –40 Deg.F to 120 Deg.F as well as remaining stable through repeated freeze/thaw cycles.

Finally, each DecTec accessory available today was developed by DecTec, specifically for DecTec membranes. These products have superior properties, as do our membranes, and complete the DecTec system.

The ease of installation allows for almost anyone to be able to transform even the most tired deck into a beautiful extension of the home as well as protect the structure and add functionality for waterproof storage or living areas.

We welcome you to review this installation guide and detail drawings. Please feel free to contact us if you have any questions or need any additional information.

Thank you for choosing DecTec for your deck roofing and waterproofing needs.

1.1 DECTEC HOT-AIR WELDING EQUIPMENT & HAND TOOLS



- Leister Triac hand welder with 0-10 heat settings and #30A1 (20 mm) nozzle
- Silicone rubber hand roller – 40 mm wide(#22D)
- Shears (Heavy Scissors)
- Olfa (or similar) razor utility knife
- Tape Measure
- Chalk Line
- Hammer
- 4”solvent resistant paint brush
- 3”putty knife
- Angle grinder or edger (7”works best)
- Grinder Backup Pad – 7 5/8”
- 36 Grit Sanding Discs for Grinder
- 1” Wood Chisel
- Tin Snips
- Small Crowbar (12”)
- 3/8” Reversible Drill (Keyless Chuck is best)
- 3/16” Masonary Drill Bit for Brick/Concrete
- 5/16” Socket Driver Bit for Drill
- Basic Drill Bit Set
- Screw Driver Bits for Drill
- Safety Glasses
- Ear Protection
- Broom or Leaf Blower
- Richard’s #8 V-Notch Trowel (1/16” x 1/16” V Notch)
- Wire brush (used to clean welder tip)
- Caulking gun
- Level
- Square/Straightedge
- Hand held Linoleum Roller (small 8”)
- 100 foot Extension Cord



Quick Tips

1. Always “walk” the deck prior to quoting and/or beginning installation. Look for any protrusions such as nail or screw heads, or construction materials, (plaster etc.), and the general condition of the deck surface. Also look to ensure the proper type of materials and construction requirements have been used. Min. 5/8” inch (15.5 mm) thick, Tongue & Groove, CDX plywood screwed at 6” intervals and glued.
2. Prep the deck using only DecPatch II patching compound and, once completely dry, grind level and smooth. Install flashings with the appropriate screws or ring nails. Use pins/plugs for plaster or concrete finishes. When quoting always round up flashing length needed to the next full length, i.e. If 43’ total is required – price the job using 48’ = 6 lengths @ 8’ each (for metal), or price at 50’ = 5 lengths @ 10’ each for Termination Bar.
3. When measuring out the deck, add 1 lin. Foot to the length and 6” to the width of each cut. This will give you a buffer for decks which may be out of square or in the event of an incorrect measure etc. Remember, if you are wrapping membrane down onto the face of the flashing, to add the amount needed to your total length and width. It is also a good idea to show the “direction” of the sheet by marking with an arrow on the back of each piece you cut with a chalk marker. Take 2 – 3 minutes now to closely examine the membrane for any visible defects in color, pattern, or construction, it is your responsibility to ensure that no product is installed with visible flaws.
4. Sweep or blow the deck off and ensure it is clean before laying out your cuts. Take a close look again to ensure it is smooth.
5. Lay out the cuts onto the deck exactly as they will be when completed, making sure they are running in the same direction, otherwise the light refraction will cause them to look like 2 different colors. Snap a line, or other wise mark, where your first piece will lay making sure it is square to the deck and you have allowed enough extra to complete the edge finish desired. This will allow you to quickly place your sheet and ensure it is straight without having to measure again. Always start from the outside edge and roll out each sheet parallel with the house. Then, once all pieces are in place, trim off the large waste amounts and fit the membrane into place. Remember to leave 6” – 8” to run up the wall, and 3” – 4” around the perimeter to allow for minor adjustments. This will be your final chance to double check your cuts and layouts, its also time to closely examine the material again for possible defects. Once installed, there will be NO provision for removal and reinstallation of goods with visible color or construction defects. It will be the sole liability of the Dealer and / or their installers.
6. Back roll, or fold back, half of the sheet over the other and spread WBA100 adhesive onto the deck surface only, using a #8 Notched Trowel, at a rate of 125 – 150 sq. ft per gallon of adhesive. If using SBA100, apply with a medium nap paint roller at approx. 80 sq. ft per gallon, divided between both surfaces, as it must be applied to both the deck and the membrane. (see complete install manual and Technical bulletins). Do not spread any adhesives onto the flashings or seam overlap areas that are going to be welded, this will contaminate the weld. Roll the sheet into the adhesive minimizing air entrapment. Starting at the center of the sheet as you roll the piece in, work to the edges using your hands, to “push” any trapped air out from under the sheet and ensure good contact with the adhesive. Roll with heavy roller after, being sure to roll in both directions. If a sheet becomes wrinkled, or still has a bubble, pull the sheet up in the affected area and lay it back in again as described. If installing another “run”, snap a chalk line 1” to 1.5” in from the edge closest to the exterior wall of the glued down sheet, this gives you a reference as to where to place the next sheet and provides a proper overlap for your seam. Always clean off the chalk, or cover it entirely over, prior to welding the seam. Otherwise you may end up “welding” the chalk into the seam making it a permanent part of the install and resulting in a very unhappy customer! Repeat the process above to install each subsequent piece. When using SBA100 you must work quickly, spreading smaller amounts of adhesive at a time as it sets up much faster than WBA100. You also will NOT be able to pull up the membrane to reposition when using SBA100. Obviously, complete contact between sheet and deck is essential with either adhesive – make sure you are using a proper spread rate.
7. Once the membrane is in place and fully adhered, all seams and terminations can be welded. Weld your seams first, then proceed to your details. Trim and exact fit all details before welding. Never cut inside corners, use a dog ear as per install manual and weld to the side which is visually less noticeable. Use DecFlash preformed flashings for ease of installation, or if experienced, cut pieces out of scrap for outside corners, posts, or boots, and weld into place. Weld all terminations to PVC clad metal and do final trimming. Use a flat, rounded edge, screwdriver to check all seams.
8. Do final site inspection and clean up all debris. Always clear off the deck and sweep or wipe clean. Leaving a clean site will be a lasting “first” impression of your customers new DecTec deck, and an immediate referral to all their friends and neighbors.

1.1 JOB CONDITIONS

- A. Only as much of the new waterproofing as can be made weathertight each day, including all flashing and detail work, shall be installed. All seams shall be cleaned and heat welded before leaving the job site that day.
- B. All work shall be scheduled and executed without exposing the interior building areas to the effects of inclement weather. The existing building and its contents shall be protected against all risks. Access decks from the exterior when possible to reduce potential damage.
- C. All surfaces to receive new membrane or flashings shall be dry. Should surface moisture occur, the Applicator shall provide the necessary equipment to thoroughly dry the substrate prior to application unless previously arranged with the contractor or builder.
- D. The Applicator is cautioned that Dectec membranes are incompatible with asphalt, coal tar, heavy oils, roofing cements, EPDM rubber, creosote, liquid applied coatings and some preservative materials. Such materials shall not come into nor remain in contact with DecTec membranes. The Applicator shall consult DecTec regarding compatibility, precautions and recommendations if unsure.
- E. Arrange work sequence to avoid use of newly constructed waterproofing as a walking surface or for equipment movement and storage. Where such access is absolutely required, ensure all necessary protection and barriers to segregate the work area, and to prevent damage to adjacent areas, is in place. A substantial protection layer consisting of plywood over felt or plywood over insulation board shall be in place for all new and existing deck areas that receive traffic during construction.
- F. Prior to and during application, all dirt, debris and dust shall be removed from surfaces, either by vacuuming, sweeping, blowing with compressed air or a leaf blower and/or similar methods.
- G. The Applicator shall follow all safety regulations as required by OSHA/WCB and any other applicable authority having jurisdiction. Care should also be taken to ensure that overloading of a deck and/or structure does not occur.
- H. Contaminants such as, but not limited to, grease, oils, solvents and tar shall not be allowed to come into contact with the membrane.
- I. Precautions should be taken when using adhesives or sealants at or near fresh air intakes or vents to prevent odors from entering the building and affecting others.
- J. Flammable adhesives, or materials, shall not be stored or used in the vicinity of open flames, sparks and excessive heat.
- K. Applicator shall immediately stop work if any unusual or concealed condition is discovered and shall immediately notify Owner of such condition in writing for correction at the Owner's expense.
- L. Site cleanup, including both interior and exterior building areas which have been affected by construction, shall be completed to the Owner's satisfaction.
- M. The Applicator should verify that any and all deck drains or scupper lines are clear of debris and not blocked before starting work. Any blockages should be reported both verbally, and in writing, to the owner or their representative. After completion of necessary work, the Dectec Applicator should also then demonstrate with the owner, or their representative, that all lines are still clear.
- N. Skyline Building Systems Inc. requires that in the rare event of a warranty claim, the owner shall allow the DecTec Applicator, our Agents and / or Employees access to visually inspect the area in question and, if necessary, take physical samples for testing purposes. NO claim will be honored without an inspection or written acknowledgment from Skyline Building Systems.

1.1 WARRANTIES

- A. DecTec 10 Year Limited Membrane Warranty
Upon successful completion of the work and receipt of the Warranty Registration Card, the DecTec Warranty will come into effect.
- B. Applicator/Contractor Warranty

The Applicator shall supply the Owner with a separate workmanship warranty. In the event any work related to waterproofing, flashing, or metal is found to be, within the Applicator warranty term, defective or otherwise not in accordance with the Contract Documents, the Applicator shall repair that defect at no cost to the Owner. The Applicator's warranty obligation shall run directly to the Owner.

PART 3 - PRODUCTS

2.1 GENERAL

- A. Components to be used other than those supplied or manufactured by DecTec must be submitted for review and acceptance by DecTec. DecTec's acceptance of any other product is only for a determination of an opinion of compatibility with DecTec products and not for inclusion in the DecTec warranty. The specifications, installation instructions, limitations, and/or restrictions of the respective manufacturers must be reviewed by the Owner's Representative for acceptability for the intended use with DecTec products. Use of non-approved accessories will automatically void the DecTec warranty.

2.2 MISCELLANEOUS FASTENERS AND ANCHORS

- A. All fasteners, anchors, nails, straps, bars, etc. shall be post-galvanized steel, aluminum or stainless steel. Mixing metal types and methods of contact shall be assembled in such a manner as to avoid galvanic corrosion. Fasteners for attachment of metal to masonry shall be expansion type fasteners with stainless steel pins. All concrete fasteners and anchors shall have a minimum embedment of 1.25 inch (32 mm) and shall be approved for such use by the fastener manufacturer. All miscellaneous wood fasteners and anchors used for flashings shall have a minimum embedment of 1 inch (25 mm) and shall be approved for such use by the fastener manufacturer.

SUBSTRATE CONDITION

- A. Applicator shall be responsible for acceptance or provision of proper substrate to receive new waterproofing materials.
- B. Applicator shall verify that the work done under related sections meets the following conditions:
 - 1. Deck drains and/or scuppers have been reconditioned and/or replaced and installed properly.
 - 2. Deck curbs, nailers, equipment supports, vents and other deck penetrations are properly secured and prepared to receive new waterproofing materials.
 - 3. All surfaces are smooth and free of dirt, debris and incompatible materials.
 - 4. All deck surfaces shall be free of water, ice and snow and completely dry.
 - 5. The Owner's Representative shall ensure that the deck is secured to the structural framing according to local building code.

New Construction

1. Wood Deck:

Approved wood deck - **The deck substrate shall be minimum 5/8 inch (15.5 mm) thick, Tongue & Groove, CDX plywood.** OSB construction of any kind is NOT acceptable. Plywood shall be installed, screwed and glued to structure, according to FM and/or local code requirements.

2. Poured Lightweight (Cellular) Concrete Substrate:

The lightweight concrete shall be installed by a trained lightweight concrete Applicator in accordance with the lightweight concrete manufacturer's requirements and industry practice. The surface shall be created with a water-based sealer accepted by the lightweight concrete manufacturer to create a surface free from dust and loose material. The wet and dry densities shall be in accordance with the manufacturer's and FM's (if applicable) requirements. Sharp ridges or other projections above the surface shall be removed before installing.

3. Poured Normal Weight Structural Concrete Deck:

The deck shall be installed and cured in accordance with industry standards. The surface shall have a smooth and level finish and shall be free of dust, excess moisture, oil-based curing agents, and loose debris. Sharp ridges or other projections above the surface shall be removed before installation of membrane.

4. Precast / Pre-stressed Concrete Panel Deck:

The deck shall be installed in accordance with the concrete panel manufacturer's requirements and industry practice. The surface shall have a smooth and level finish and shall be free of dust, moisture, oil or loose debris. All joints between pre-cast units shall be grouted. Any differentials in height between pre-cast units shall be feathered for a smooth transition. Sharp ridges or other projections above the surface shall be removed before installation of membrane. Panels shall be secured to structural supports as recommended by architect (by others).

A. Renovation with Removal of Existing Membrane

General Criteria:

The Owner's Representative and Applicator shall determine the condition of the deck and sub structure. Deteriorated decking or wet or deteriorated materials are to be removed and replaced. After removal of existing membrane, inspect deck substrate and reuse only if dry and in stable condition. Install new DecTec membrane on new approved acceptable substrate only.

B. Renovation Over Existing Membrane

General Criteria:

Installing DecTec over existing membranes or coatings, paints, or sealant of any kind, is not acceptable. The Owner's Representative and Applicator shall determine the condition of the deck substrate and structure. Deteriorated materials are to be replaced. If substrate and structure are acceptable, fasten minimum 5/8" inch (15.5 mm) thick, Tongue & Groove, CDX plywood over existing membrane into structural joists and then apply DecTec on new substrate.

SUBSTRATE PREPARATION

Ensure that all plywood joints, knotholes and voids are filled using DecPatch compound. This cement based filler shall be mixed as per the directions and forced into all areas using a putty knife or similar. Raised or uneven areas should be built up and feathered back to provide a smooth transition. Once the Patch has dried it should be sanded or ground down, using an angle grinder, belt sander or similar, to provide a smooth surface and eliminate any rough edges, gaps, joints etc. It is important to note that the more attention paid to this area of installation, will greatly enhance the finished overall appearance. Any irregularities under the membrane will be "telegraphed" through to the surface. Be sure to blow off or sweep the deck after sanding.



D. **DecTec SBA 100 Adhesive:**

1. Over the properly installed and prepared substrate surface, DecTec SBA 100 adhesive should be applied using solvent-resistant 3/4 inch (19 mm) nap paint rollers. The adhesive is to be applied to the substrate at a rate according to DecTec requirements. The adhesive shall be applied in smooth, even coating with no gaps, globs, puddles or similar inconsistencies. Only an area that can be completely covered in the same day's operations, shall be coated with adhesive. The first layer of adhesive shall be allowed to dry completely prior to installing the membrane. **DO NOT APPLY ADHESIVE TO SEAM OR OTHER AREAS TO BE HOT-AIR WELDED.**
2. When the adhesive on the substrate is dry, the DecTec membrane is unrolled. Adjacent sheets shall be overlapped a minimum of 1.5". Once in place, one-half of the sheet's length shall be turned back and the underside shall be coated with DecTec SBA 100 adhesive at a rate of 1/2 gallon per 100 ft² (0.2 liters/m²). When the membrane adhesive has dried slightly to produce strings when touched with a dry finger, the coated membrane shall be rolled onto the previously coated substrate being careful to avoid wrinkles. **Do not allow adhesive on the underside of the DecTec membrane to dry completely.** The amount of membrane that can be coated with adhesive before rolling into substrate will be determined by ambient temperature, humidity and applicator experience. The bonded sheet shall be pressed firmly in place with a linoleum roller by frequent rolling in two directions. The remaining un-bonded half of the sheet shall be folded back and the procedure repeated. **CAREFUL NOT TO ALLOW AIR TO BE TRAPPED UNDER THE MEMBRANE.**

Notes:

- a) The Applicator shall count the amount of pails of adhesive used per area as the installation progresses to verify conformance to the specified adhesive rate.
- b) No adhesive shall be applied in seam areas.
- c) All membrane shall be applied in the same “direction” to avoid color changes from light reflection.
- d) All dyelots must be checked to ensure same dyelot pieces are being welded together. Slight color variations between dyelots is normal and will not be considered a defect.

Spread Rates for SBA100 adhesive used to attach the membrane to the substrate, either horizontally or vertically. Use exclusively for on-grade concrete installations and vertical flashings, can also be used on plywood substrates.

	<u>Substrate Rate</u> gallons/100 ft ²		<u>Membrane Rate</u> gallons/100 ft ²		<u>Total Rate</u> gallons/100 ft ²	
Metal or Aluminum	0.75	+	0.50	=	1.25	
Smooth Plywood	1.00	+	0.50	=	1.50	
Structural Concrete	1.25	+	0.50	=	1.75	
Cellular Concrete	1.50	+	0.50	=	2.00	

Notes:

- a. Due to an increase in viscosity when outdoor temperatures during installation are below 40°F (5°C), add 0.5 gal/100 ft² (0.2 l/m²) to rate for estimating purposes. Do not install when air temperature is within 5°F of dew point. Solvent evaporation time increases significantly when temperatures drop. Ensure first layer of DecTec SBA 100 is fully dry before second layer is applied to the back of the membrane for proper reactivation.



C. DecTec WBA 100 Adhesive:

- Over the properly installed and prepared absorbent substrate, DecTec WBA 100 adhesive shall be poured out of the pail and spread using a 1/16" x3/32" V notched trowel. The adhesive is to be applied to the substrate at a rate according to DecTec requirements (no adhesive is placed on back of the membrane). The adhesive should be applied in an even coating with no holidays, globs, puddles, or similar irregularities. The formation of a film on the surface of the adhesive shall not be allowed to occur. Cover the deck with adhesive working away from the membrane. The membrane is to be carefully unrolled into the wet adhesive while the edges are overlapped a minimum of 1.5". The membrane is then to be pressed firmly into the adhesive layer with a linoleum roller by frequent rolling in both directions, insuring all trapped air is removed.

	Substrate Rate gallons/100 ft ²		Membrane Rate gallons/100 ft ²		Total Rate gallons/100 ft ²
Smooth Plywood	0.70	+	0	=	0.70
Structural Concrete	0.80	+	0	=	0.80
Cellular Concrete	0.70	+	0	=	0.70

Notes:

- The Applicator shall count the amount of pails of adhesive used per area as the installation progresses to verify conformance to the specified adhesive rate.
- No adhesive shall be applied in seam areas.
- All membrane shall be applied in the same "direction" to avoid color changes from light reflection.
- All dyelots must be checked to ensure same dyelot pieces are being welded together. Slight color variations between dyelots is normal and will not be considered a defect.
- WBA100 adhesive should not be applied, allowed to cure, or stored below 50°F (10°C).
- Use a linoleum roller to consistently and evenly press the membrane into the adhesive layer.
- There is a significant increase in drying time due to an increase in humidity and/or a decrease in temperature. Do not install when outdoor or substrate temperatures during drying period are expected to fall below 50°F (10°C)
- WBA100 is not to be used on any vertical surfaces unless held in place by means of nailing, stapling etc. and **ONLY** when subsequent construction, such as siding or stucco, is to be installed over top of the vertical membrane and provide a proper weathertight system. This additional construction **MUST** be completed before inclement weather or other uncontrollable environmental forces may compromise the waterproofing of the deck.





3.1 HOT-AIR WELDING OF SEAM OVERLAPS

A. General

1. All seams shall be hot-air welded. Seam overlaps should be a minimum of 1.5” wide when hand welding, except for certain details or as per code requirements.
2. Recommended welding equipment is the Leister Triac hand welder, available from DecTec.
3. All membrane to be welded shall be clean and dry. No adhesives shall be present within the lap areas.

B. Hand-Welding

Hand-welded seams shall be completed in two stages.

1. Using a Leister Triac hand welder, equipped with the 30A1 nozzle or similar, the back edge of the seam shall be welded with a narrow but continuous weld to prevent loss of hot air during the final welding.
2. The nozzle shall be inserted into the seam at a 45 degree angle to the edge of the membrane. Once the proper welding temperature has been reached and the membrane begins to “flow,” the hand roller is positioned perpendicular to the nozzle and pressed lightly. For all seams, the ¾ inch (20 mm) wide nozzle is recommended for use. The welder and the roller are moved together in a steady continuous motion – never “start and stop”. Do not allow the liquefied membrane to “bleed out” from between the two layers.

D. Quality Control of Welded Seams

1. The Applicator shall check all welded seams for continuity using a rounded screwdriver. Visible evidence that welding is proceeding correctly is smoke during the welding operation. On-site evaluation of welded seams shall be made to all seams on every project. Any gaps or un-welded areas must be re-welded before proceeding.



3.2 MEMBRANE FLASHINGS To be constructed from DecTec "Guardian" membrane.

All flashings shall be installed concurrently with the DecTec membrane as the job progresses. No temporary flashings shall be allowed without the prior written approval of the Owner's Representative. If any water is allowed to enter under the newly completed decking membrane, the affected area shall be removed and replaced at the Applicator's expense. Flashing shall be adhered, where applicable, using DecTec SBA100 solvent adhesive, to compatible, dry, smooth, and solvent-resistant surfaces. Use caution to ensure adhesive fumes are not drawn into the building

- A. DecTec SBA 100 Adhesive for Membrane Flashings
 - 1. Over the properly installed and prepared flashing substrate, DecTec adhesive shall be applied according to instructions found on the Product Data Sheet. The DecTec adhesive shall be applied in smooth, even coats with no gaps, globs or similar inconsistencies. Only an area which can be completely covered in the same day's operations shall be flashed. The bonded sheet shall be pressed firmly in place with a hand roller.
 - 2. No adhesive shall be applied in seam areas that are to be welded. All panels of membrane shall be applied in the same manner, overlapping the edges of the panels as required by welding techniques.
- B. All flashings shall extend a minimum of 8 inches above substrate level unless otherwise specified by owner or his representatives, and/or local code requirements.
- C. All flashing membranes shall be consistently adhered to substrates. All interior corners shall be folded, not cut and exterior corners shall be cut and hot-air welded into place. (See detail drawings). No bitumen shall be in contact with the DecTec membrane.
- D. DecTec flashings shall be terminated according to recommended details.



INSIDE CORNERS

Field piece is to “flash” up adjoining wall a minimum of 6”. Apply adhesive as per adhesive instructions, and hand rub the membrane flat onto the deck and wall surfaces starting first with one side (A), then the other (B). Once both walls are flashed in all excess material should form a pocket in the corner. Ensure both sides are adhered as tightly into the corner as possible. Crimp the two pieces together and crease making sure everything is as tight as possible. Then weld the two pieces of the pocket together forming a single “flap”. Then fold the “flap” over either left or right depending upon best aesthetics and weld to wall flashing as shown below.

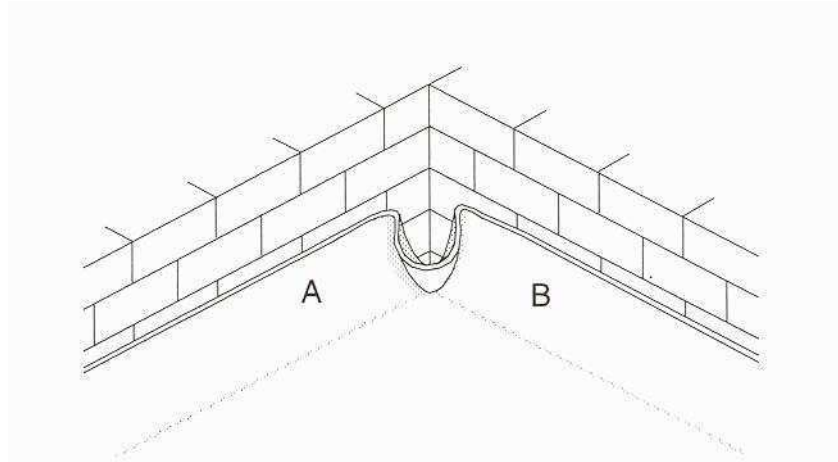

WELD AREAS (“Inside” of 2 flaps – squeeze together to make “pig’s ear”.)

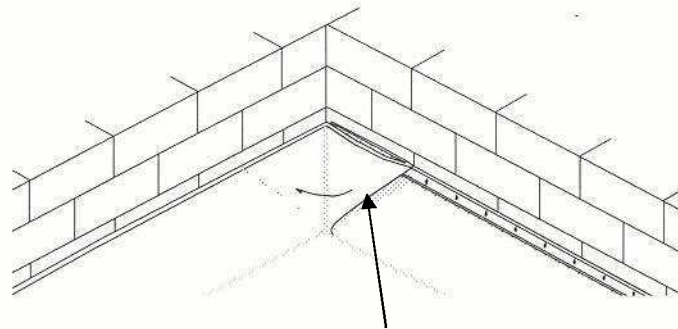
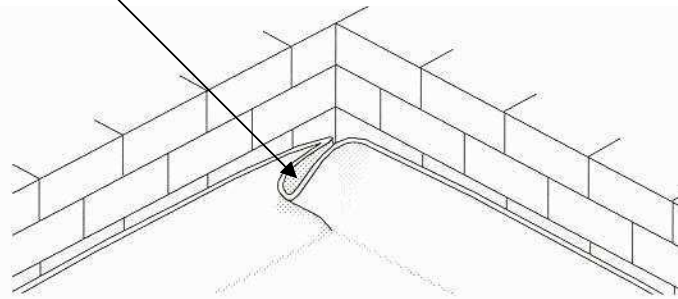

WELD AREAS
(Weld in behind “ear” and fuse to membrane on wall, or vertical, surface)

OUTSIDE CORNERS

Field piece is to “flash” up adjoining wall a minimum of 6”. Cut membrane at a max. angle of 45 Degree into the corner to allow it to “fall” around the corner. After fully gluing down the membrane, and performing field seams, create a corner boot by taking a roughly 12”square piece of DecTec, round off one corner with your shears. Enlarge the rounded corner by heating the back (smooth) side until it appears glossy. Using both hands, “work” the product in an outward motion so as to stretch the material wider. (see diagram at bottom). Place the boot ,with the rounded corner laying flat onto the field piece, ensuring it is overlapping all edges of the field piece, and trim off excess. Once the boot is properly placed, weld completely.

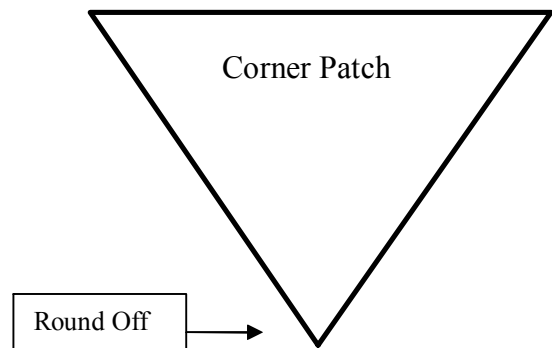
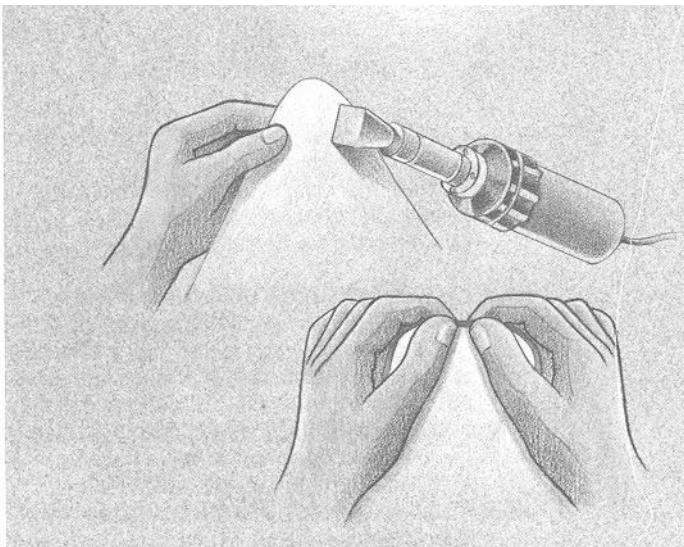
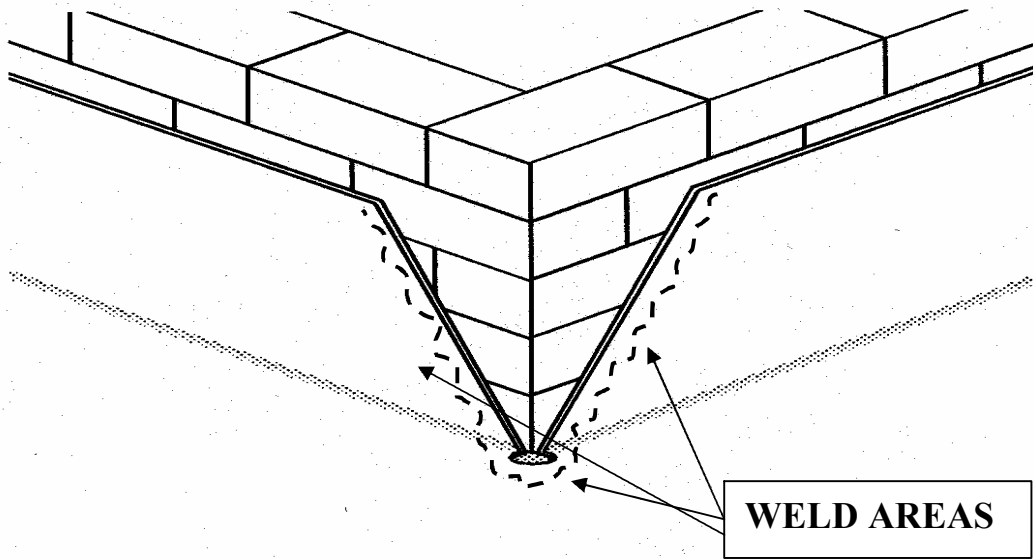

Round off “point” of triangle shaped outside corner patch, heat and work as shown in illustration at left. Weld onto existing field and flashed membrane.

FLASHING A ROUND PENETRATION

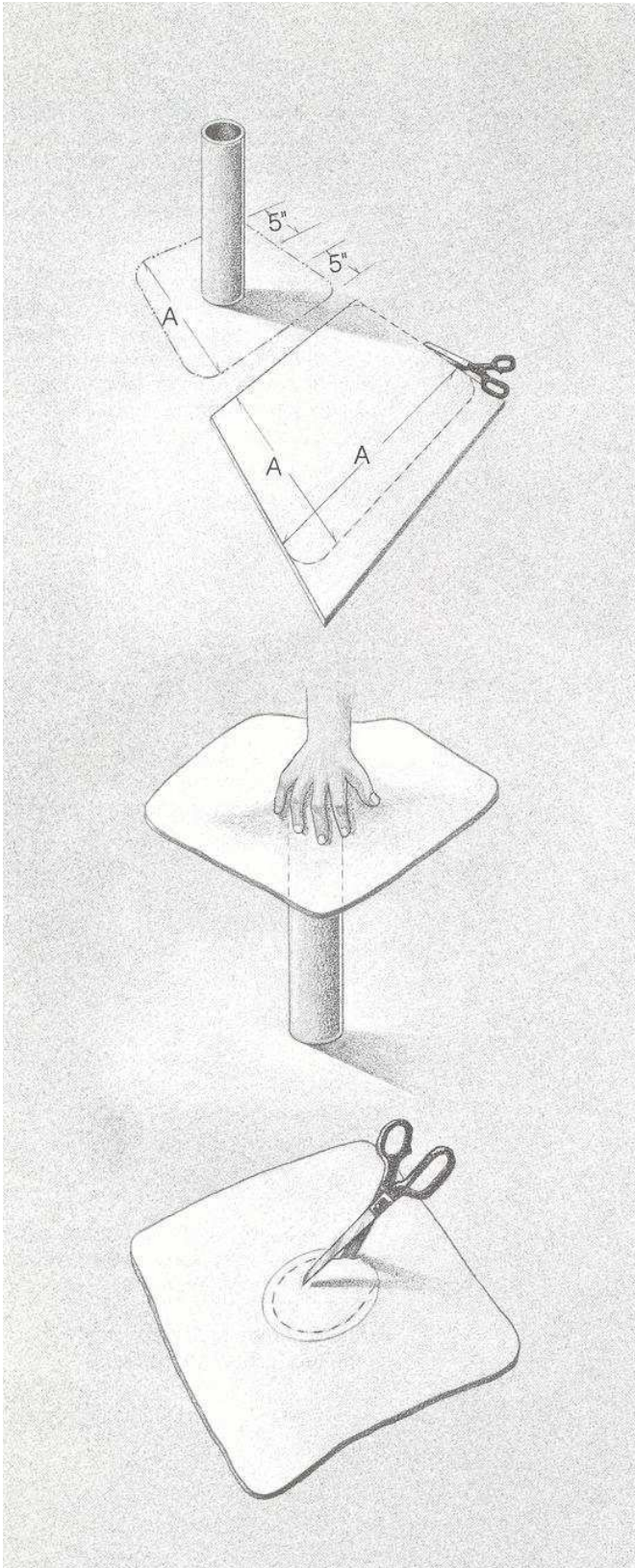

1. Cut DecTec field sheet tight to the round penetration. Cut an additional piece of DecTec approx. 12" to 16" square, (Depending upon pipe size), to be used as a base plate.

2. Center the base plate over the top of the penetration and trace π onto the membrane to show diameter.

3. Then cut a hole in the membrane that is $\frac{1}{2}$ " smaller all the way around, than the traced diameter of the penetration. Stretch the base plate down over the stack until it is flat onto the field piece except where it will "neck" up the base of the stack. Make sure the textured side is up to match the field.

(CON'T)

4. Cut a piece of DecTec to extend 2 inches above the height of the penetration and wrap around allowing for a 1" to 2" overlap, and weld together creating a tube. (Make sure not to wrap the pipe overly tight, as you will not be able to slide it off after welding).

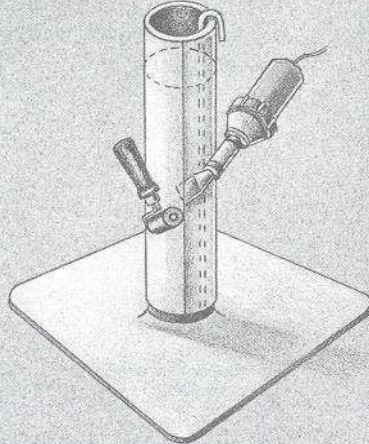

5. Flange the bottom 1" by heating until glossy and working with your fingers in an outward motion so as to expand the membrane and creating a scalloped effect with the base.

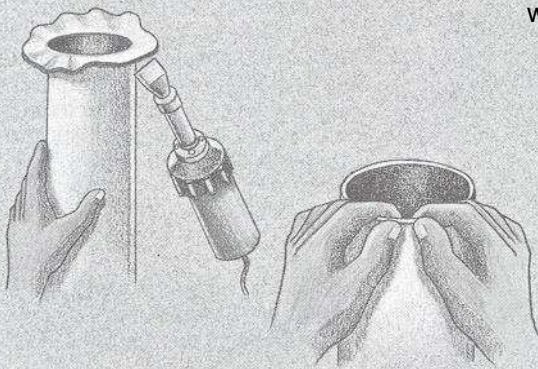

6. Slide the flashing with scalloped end down, back onto the penetration. Weld the scalloped "flange" onto the base plate and then weld the base plate to the field sheet. Install a hose clamp around the top and caulk the leading edge.

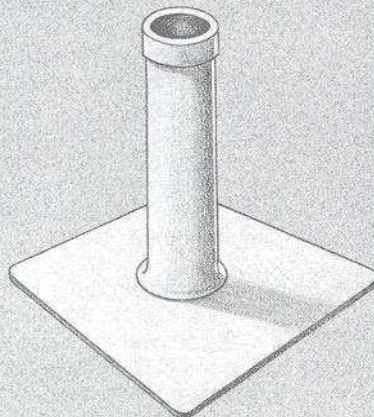

7. Check all welds after they have thoroughly cooled and re-weld any inconsistencies.

DecTec NDR 4-1 Drain Product Data Sheet and Installation Instructions.

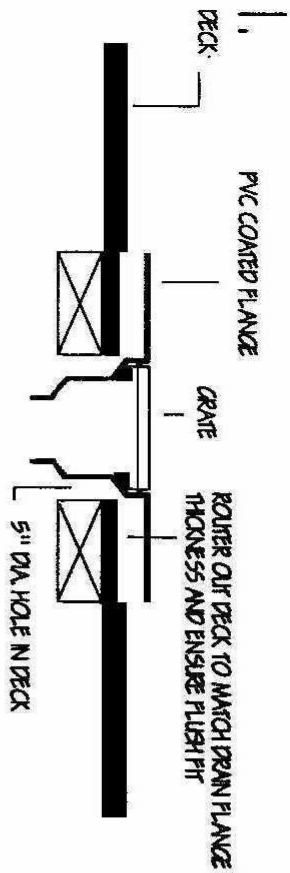

1. Find low spot on deck.
2. Cut 5" Diameter hole to accommodate drain sump.
3. Place drain through opening making sure it is centered, and trace around flange.
4. Remove drain & router within traced circle of drain flange to a depth that will allow the top of the flange to sit flush with the deck.

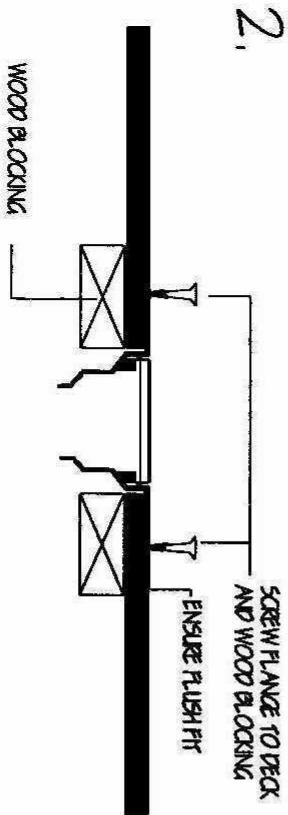

5. Ensure that there is proper solid blocking (1.5" thick minimum) under extent of flange area.
6. Cut drain to required length / pipe size, and place in hole setting the flange into the routed area so that top of flange is flush with surrounding deck surface.
7. Screw flange through deck and into blocking with self-tapping, self-counter-sink screws provided. **NOTE:** 24 screws are provided with each drain, use as many as are necessary to secure the drain to the deck without "Oil Canning" the flange. Take care not to place screws too close to inside edge of flange to ensure proper coverage of weld area between membrane and flange.

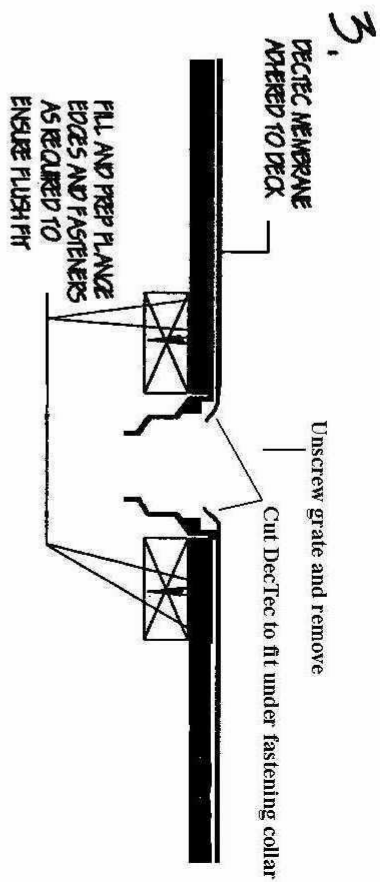

8. Fill and prep flange edge and screws to same standard as deck joints and cracks. Remove grate and grate screws before beginning.
9. Install DecTec membrane to deck with adhesive. Cut hole in membrane to fit under fastening collar and hot air weld to PVC coated drain flange.

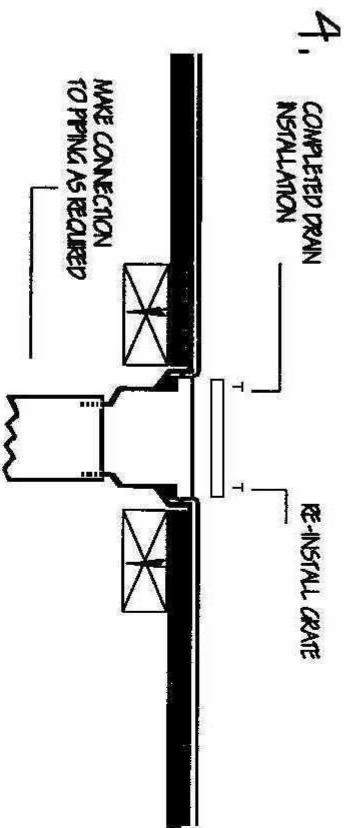

10. Reinstall grate with supplied stainless steel screws ensuring membrane is fully clamped down but not visible or blocking grate slots.
11. Complete piping to appropriate location. Piping may be connected to drain by use of appropriate adhesive, optional EPDM Super Seal, or mechanical joint. **NOTE:** Type of piping, attachment, and number of drains are determined by local design authority in accordance with local codes and requirements.
12. Drain installation is now complete and should be tested before leaving jobsite and periodically to ensure proper function.

3.3 METAL FLASHINGS

- A. Metal details, fabrication practices and installation methods shall conform to the applicable requirements of the Owners Representative, Project Engineer/Architect or DecTec.
- B. Metal is not covered under the DecTec warranty.
- C. Complete all metal work in conjunction with waterproofing and flashings so that a watertight condition exists daily.
- D. Metal shall be installed to provide adequate resistance to bending to allow for normal thermal expansion and contraction.
- E. Metal joints shall be watertight.
- F. Metal flashings shall be securely fastened into solid wood blocking. Fasteners shall penetrate the wood nailer a minimum of 1 inch (25 mm).
- G. Counter flashings shall overlap base flashings at least 4 inches (100 mm).

3.4 DecCLAD PVC METAL BASE FLASHINGS/EDGE METAL

All flashings shall be installed concurrently with the waterproofing membrane as the job progresses. No temporary flashings shall be allowed without the prior written approval of the Owner's Representative. If any water is allowed to enter under the newly completed decking due to incomplete flashings, the affected area shall be removed and replaced at the Applicator's expense.

- A. DecCLAD PVC metal flashings shall be formed and installed per the Detail Drawings.
 - 1. All metal flashings shall be fastened into solid wood nailers with two rows of post galvanized flat head annular ring nails, 4 inches (100 mm) on center staggered. Fasteners shall penetrate the nailer a minimum of 1 inch (25 mm) or as dictated by Local Building Code.
 - 2. Metal shall be installed to provide adequate resistance to bending and allow for normal thermal expansion and contraction. Adjacent sheets of DecCLAD PVC clad metal shall be spaced 1/4 inch (6 mm) apart. A 4 inch minimum (100 mm) wide strip of DecTec flashing membrane shall be hot-air welded over the joint within 3/4" of the join on either side.

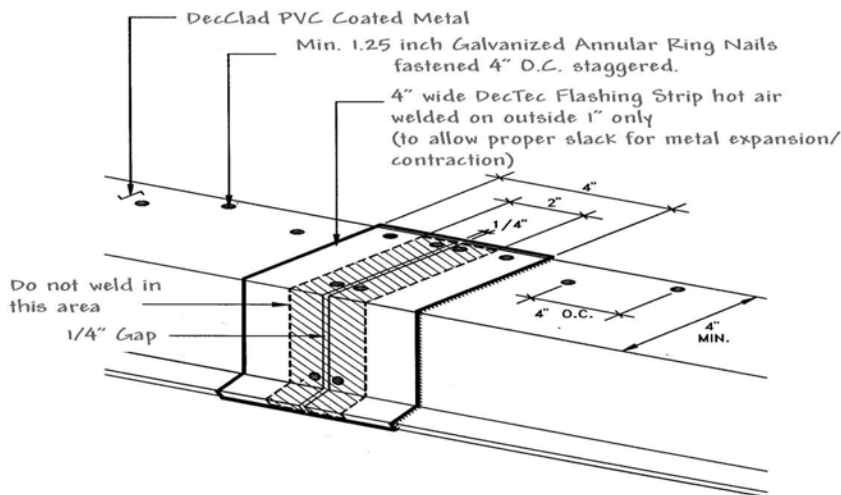



Optional Installation of Edge Metal by using router on deck edge to make metal flush and ensure positive watershed.

4.0 COMPLETION

- A. Prior to demobilization from the site, the work shall be reviewed by the Owner’s Representative and the Applicator. All defects noted and non-compliances with the Specifications or the recommendations of DecTec shall be itemized in a punch list. These items must be corrected immediately by the Applicator to the satisfaction of the Owner’s Representative prior to demobilization.

GENERAL/ MISC.

DecTec has attempted to obtain information from the manufacturers of other products often used in conjunction with DecTec products with respect to the characteristics of such products, as well as their compatibility with DecTec’s products. In as much as these other products as supplied in the field are subject to possible variation in their productions, and in as much as their specifications and performance characteristics are subject to change without notification by the manufacturers, DecTec expressly excludes from its warranty any responsibility for the performance or quality of the products of others used in conjunction with DecTec products. DecTec provides this manual as a guide only in technical support to applicators, architects or deck designers/specifiers. DecTec assumes no liability for error in design of or for misuse of this guide specification. The deck designer, engineer, architect or contractor must verify suitability of the specification and details.

HEALTH & SAFETY

The safety of every contractor on all jobs should always be ensured. It is the responsibility of the management of the company to educate and inform its employees in the particular precautions and safety measures which should be observed at the job site.

DecTec materials have been evaluated by the National Institute of Occupational Safety and Health (NIOSH) and have been found to pose no hazard or danger to the worker.

“NIOSH concludes that no health hazard from exposures to solvent contained in the adhesive, or hydrogen chloride from the heat sealing of polyvinyl-chloride roofing material existed during the period of the survey.”

NIOSH does make the following recommendations for ensuring the safe use of DecTec materials:

1. Workers should maintain an upwind position whenever possible to minimize solvent exposures.
2. Skin contact with the adhesive should be avoided to prevent possible dermatitis.
3. Confined spaces or areas of restricted airflow should be entered with air purifying, organic vapor cartridge respiratory protection.
4. Workers should be instructed to cease work and find fresh air immediately at the first signs of solvent intoxication (light-headedness, headache, dizziness, and drowsiness).

More specific information regarding the contents and safe use of specific DecTec products may be obtained by contacting DecTec Technical Department. Consult all relevant Material Safety Data Sheets.

In addition to the above precautions for safe use of DecTec materials, the contractor is also cautioned that DecTec membranes do become slippery when excessively wet, frosted or ice covered, and any foot traffic in the presence of water or moisture on the membrane surface should be conducted with care. The building owner's personnel should also be notified by the contractor that this condition exists. Further, areas of anticipated construction traffic by others, should be protected from damage.

General comments for use

DecTec membranes are defined as “Articles” and are therefore exempt from the requirements of the OSHA Hazard Communication Standard (29CFR 1910).

This information sheet is provided as a guide and cannot be considered all-inclusive or absolute. Heat sealing, and other heat applications, may subject personnel to potentially hazardous situations, particularly in closed or confined areas.

Chemical name

Polyvinyl chloride (plasticized) - (CH₂CHCL)_n.

Handling

No personal protective equipment is required with normal handling which is typical of similar PVC products such as auto seat covers, home furniture, baby furniture, tarpaulins, handbags, window shades, flooring, and footwear.

Flammability and combustion

During storage and use, DecTec membranes do not present a flammability hazard; they do not flame, but are self-extinguishing. During combustion PVC releases HCL gas which, with water, can create hydrochloric acid. Other by-products include CO and others. Smoke produced during combustion should not be inhaled as is also true for smoke produced from wood, paper, or other materials burned under similar poor combustion conditions.

Scrap disposal

Disposal of scrap vinyl presents no special problems. Because it is an inert material, the preferred method is burial in a properly operated landfill. However, any disposal must comply with all local, State, and Federal regulations. Incineration under good combustion conditions such as found in forced draft incinerators, is the alternate disposal procedure.

DISCLAIMER

This information and recommendations contained herein are offered as a service to our customers and are not intended to relieve the user from responsibility. The information and recommendations provided, are believed by DecTec to be accurate at the time of preparation, or obtained by sources believed to be generally reliable. DecTec makes no warranty concerning their accuracy and will not be liable for claims relating to any use regardless of whether it is claimed that the information or recommendations are inaccurate, incomplete, or otherwise misleading.

