



RhinoBond®

INDUCTION FASTENING SYSTEM

Non-penetrating fastening system for thermoplastic roofing

Owner's Manual

FEATURING



IMPORTANT!
Save this manual
and read it in
full before use.



153 BOWLES ROAD
AGAWAM, MA 01001
800-633-3800
WWW.OLYFAST.COM

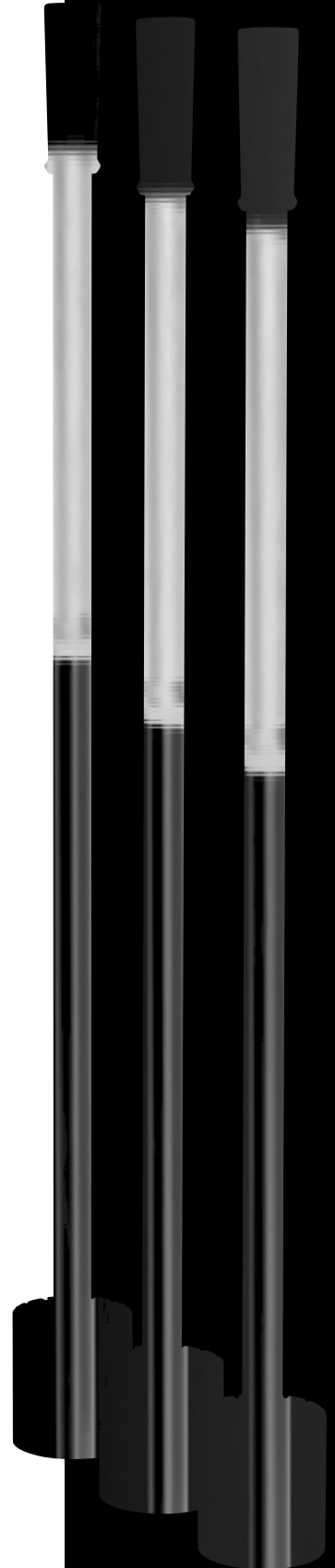
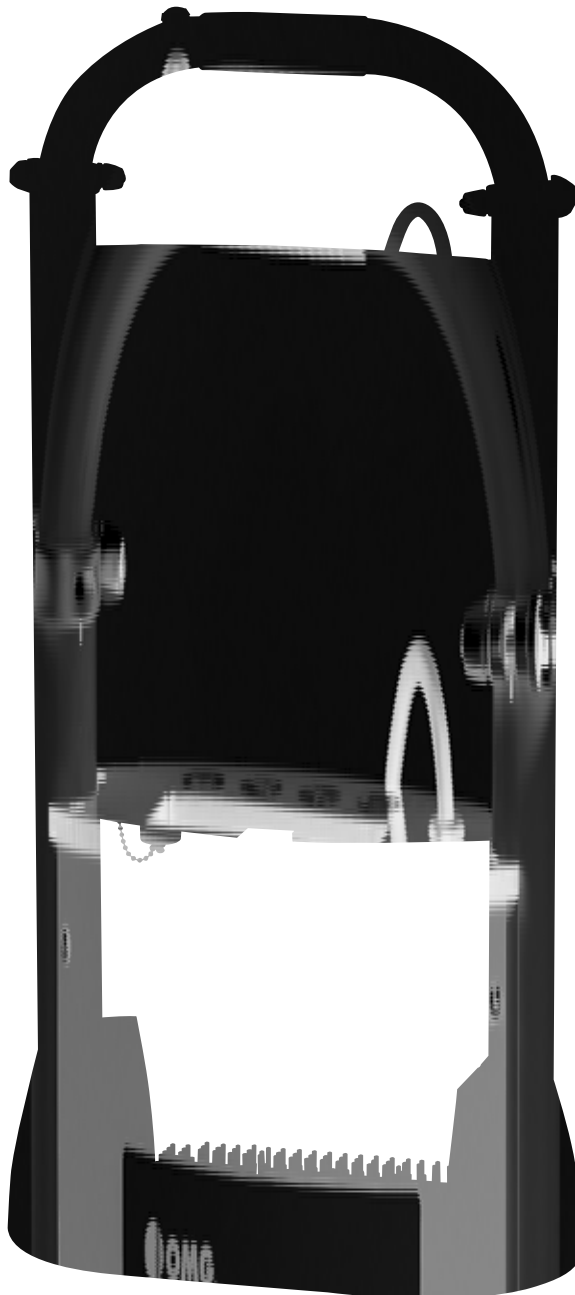

Introducing the RhinoBond® System

Congratulations! You have in your hands one of the industry's most advanced fastening systems for installing thermoplastic membrane roofing. RhinoBond is a portable, easy-to-use system that fastens thermoplastic membrane to the substrate using microprocessor-controlled induction welding.

Roofing installed this way has **several benefits:**

- **Creates no point of entry for moisture**
- **Has superior wind uplift resistance**
- **Requires 25–50% fewer fasteners per square** to meet FM 1-90 uplift requirements.

Although the RhinoBond tool is lightweight and portable, it uses a powerful induction heating system that creates a strong bond between thermoplastic roofing materials and fastening plates. The technology that makes this possible, SINCH Technology, is a compact microprocessor-controlled electromagnetic induction bonding process. Today, this rugged technology is being used to revolutionize industrial and consumer applications.

While RhinoBond is a safe, tested tool, we caution you to be sure that every member of your crew has a thorough understanding of the RhinoBond System before attempting to use it. Read, understand and follow all instructions.

Thank you for choosing the RhinoBond System. Please send us your feedback and suggestions at any time. We look forward to hearing from you!

Sincerely,

RhinoBond Product Development Team
OMG, Inc.
info@olyfast.com
rhinobond@olyfast.com
800-633-3800
www.olyfast.com

See full warranty information on page 10 of this manual.

RhinoBond® and SINCH Technology® are registered trademarks of OMG, Inc., a leading provider of innovative fastening solutions and products for the construction industry.

Patent protected.

Contact your roofing membrane manufacturer for the most current list of approvals.



Table of Contents

Safety Instructions	1
RhinoBond Tool	2
System Description	
RhinoBond System Components	3
Tools Required.....	3
Operating Instructions	
Step 1: Install the Plates.....	4
Step 2: Calibrate the RhinoBond Tool	5
Bond Results.....	6
Calibration Tips.....	6
Step 3: Bond the Membrane	7
RhinoBond Weld Test	7
The RhinoBond Display	
Display Functions	8
Menu Options/Features.....	8
Error Messages.....	9
Warranty Information	10

WARNING

The RhinoBond System produces heat that can seriously injure people and damage metal objects. Please be sure that you and your crew members read and understand all instructions in this manual before attempting to use the RhinoBond System. Failure to follow all instructions could result in **property damage, serious personal injury, electric shock or death.**

Read All Instructions

DO NOT USE THIS TOOL if you have (or anyone near you has) a **pacemaker, surgical implant, prosthesis or other medical device.** The RhinoBond tool may interfere with their proper operation.

DO NOT activate tool over metal objects in or on the floor.

DO NOT use the cord to carry the tool.

UNPLUG THE CORD before attempting to inspect or clean the tool, or you risk electric shock.



DO NOT allow any object containing metal, such as keys, jewelry, watches etc., within 3 inches of the bottom of the tool during use.



DO NOT activate tool over the power cord.



KEEP THE CORD AWAY FROM heat, liquids, sharp edges and moving parts.



IF THE CORD IS DAMAGED, stop using the tool and contact your authorized RhinoBond System Service Technician for repair.



STAY ALERT. Do not use this tool when tired or under the influence of drugs, alcohol or medication that can alter your awareness.

SAVE THESE INSTRUCTIONS

RhinoBond Tool

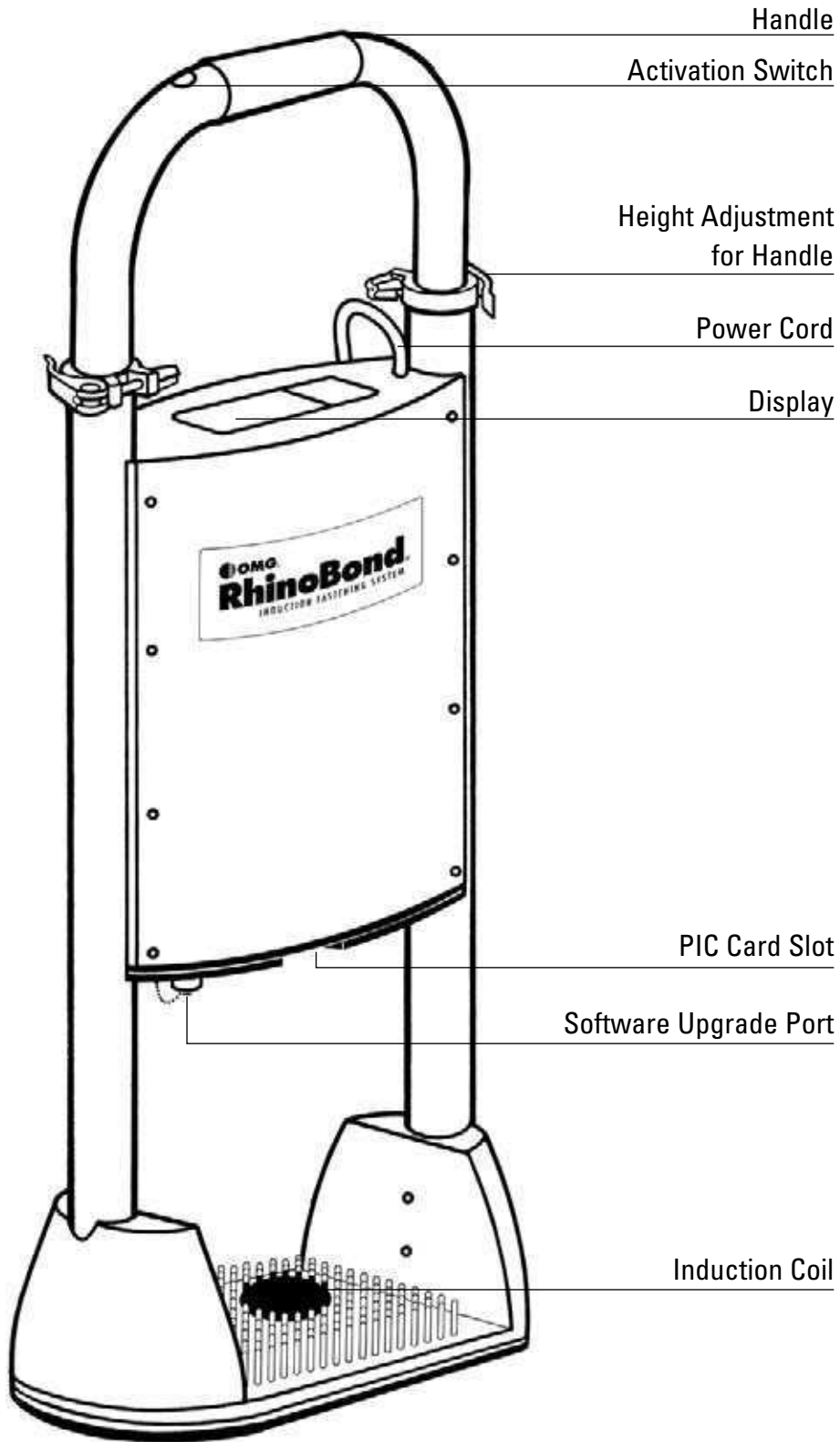

System Description

RhinoBond System Components



RhinoBond Tool
with carrying case



Cooling Clamps
6 included with carrying case



RhinoBond Fasteners and Plates
(Order separately to coordinate with specific roofing materials.)

Tools Required



Stable Power*
110–125 volts, 60 Hz
*Use 5,000 watt (min.) generator with one 20A GFCI protected circuit per tool. Two tools per 5,000 watt generator.



Power Cord
100 feet maximum
12 gauge minimum

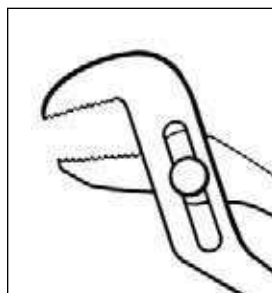

Pliers

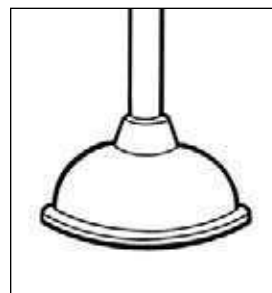

Heavy Duty Plunger

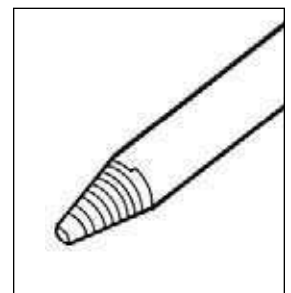

Grease Pencil

Operating Instructions

STEP 1: INSTALL THE PLATES

Always use the manufacturer's specifications when installing a fastening pattern.

When using the RhinoBond tool, it is important to install plates in a straight line. This will improve system performance and help you more easily identify plates under the membrane.

Example:

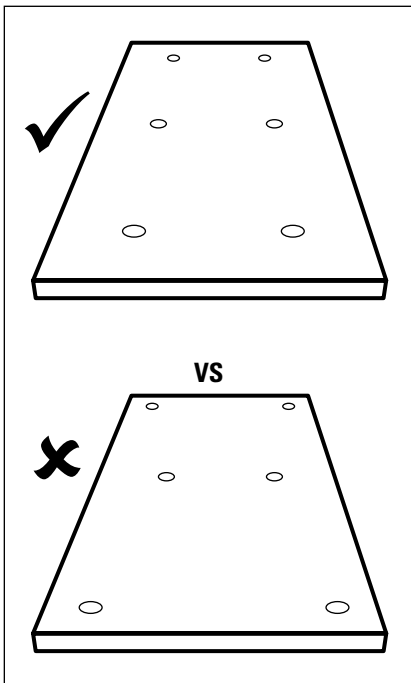

IMPORTANT TIP

Based on roofing manufacturer's fastening pattern, use chalk lines to guide fastener/plate placement.

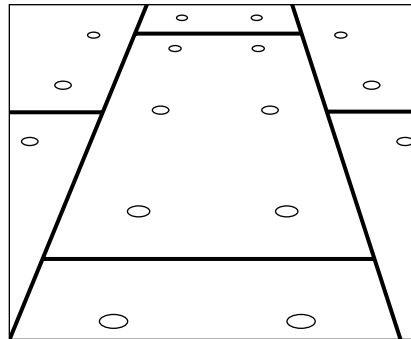

Lay insulation over substrate. Place plates in pattern specified by roofing system manufacturer.

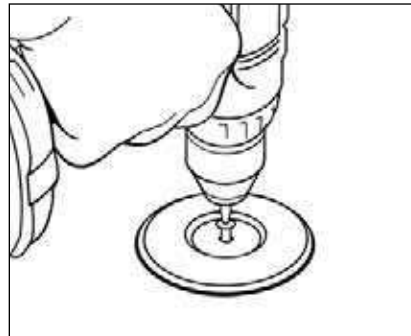

Secure plates using RhinoBond fasteners.

IMPORTANT TIP

Use only RhinoBond fasteners. For best installation results, use a variable speed screw gun (2,500 rpm max.).

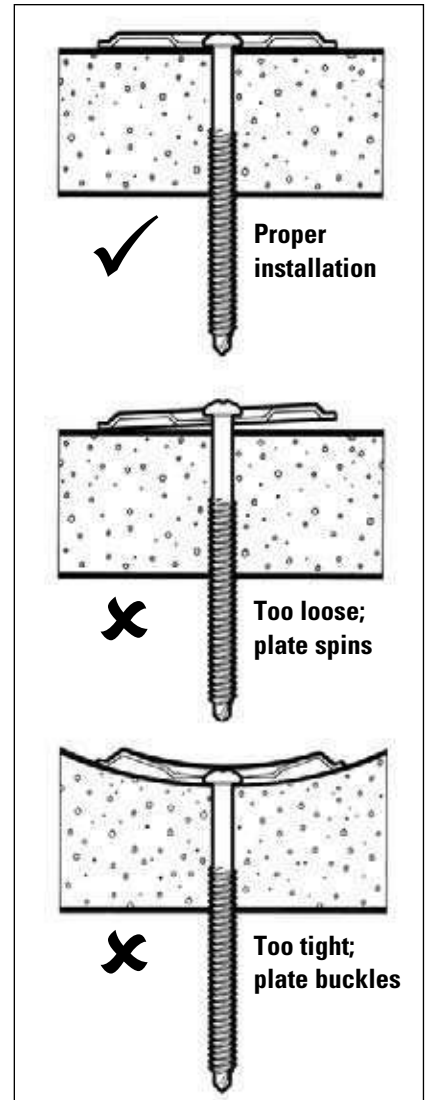

WARNING: Do not overdrive fasteners.

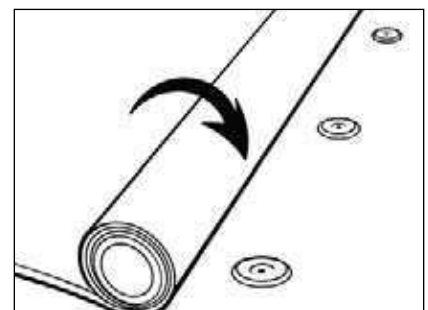

Lay membrane over the plates.

STEP 2: CALIBRATE THE RHINOBOND TOOL

Adjust the RhinoBond tool for maximum bond strength based on the ambient temperature (from 0°F to 120°F) and membrane thickness. Adjust the energy level to produce an optimal bond. Start calibration at 0 and test samples at +1, +2, +3, etc.

IMPORTANT TIP

Whenever the ambient temperature changes by 15°F (warmer or colder) recalibrate the RhinoBond tool.

Use the following calibration process to adjust the energy setting **for each tool** to the appropriate level for the conditions on the job.

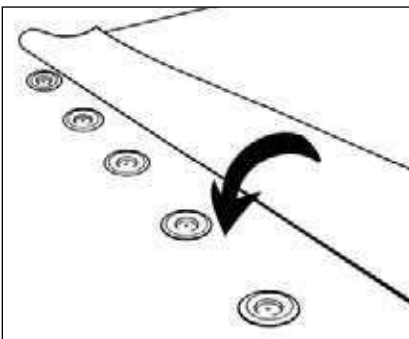

Place 5 plates on a sample of your insulation, 10" apart. (Do *not* use screws.) Lay a sample of your membrane over the plates.

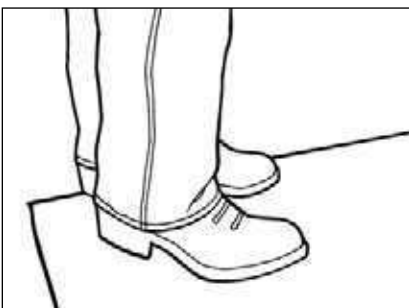

Locate each plate by rubbing the membrane with the sole of your shoe.

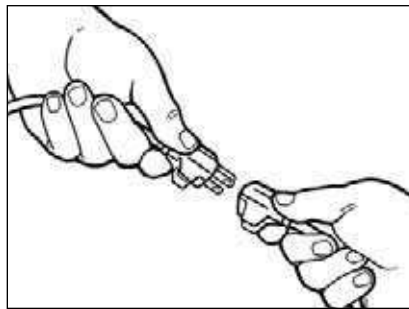

Plug the RhinoBond tool into a stable 120V/20A energy source.

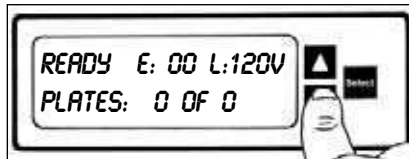

Determine initial energy setting to produce an optimal bond.

Press ▲ or ▼ next to the display to change the energy setting to the appropriate initial setting, then press **Select**.

THIS IS A GUIDELINE ONLY. Each tool should be calibrated based on the specific application conditions. If using more than one tool, calibrate each tool individually as proper settings may vary from tool to tool.

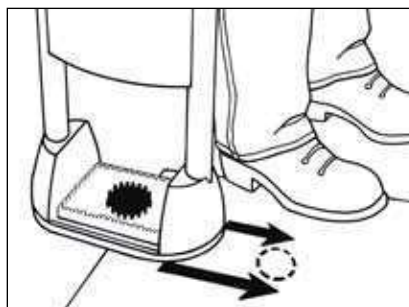

Center red circle of the RhinoBond tool directly over the first plate.

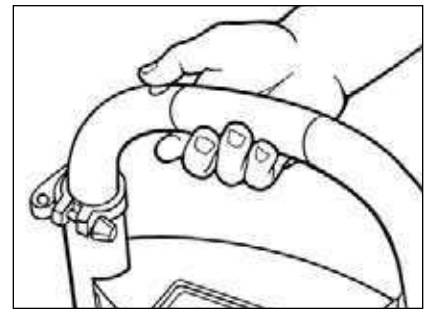

Activate the weld using the Activation button on the handle. **WARNING: Do not move RhinoBond tool during cycle.**

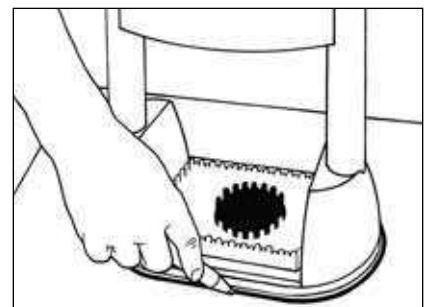

While the RhinoBond is activated (welding), trace around the base of the tool with a grease pencil. This will help you judge your accuracy in centering the coil over the plate.

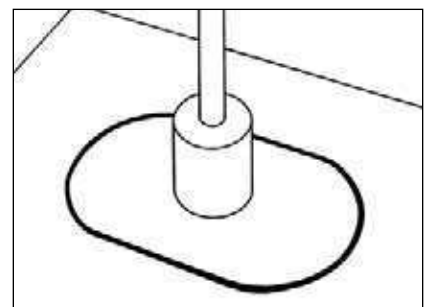

Remove RhinoBond tool after the cycle ends and immediately set a cooling clamp directly onto the center of the plate.

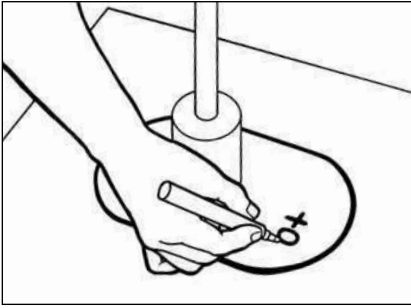

Mark the energy setting next to the plate position with a grease pencil.



Increase energy setting using **▲** to reach +1 and **Select** to accept the new setting. Weld the second plate and trace around it. Immediately place the cooling clamp onto the plate and mark this new setting.

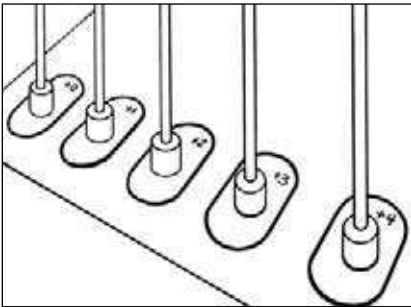

Repeat this process for each plate, increasing the energy +1 unit each time. Allow plates to cool completely, at least 5 minutes, before continuing.

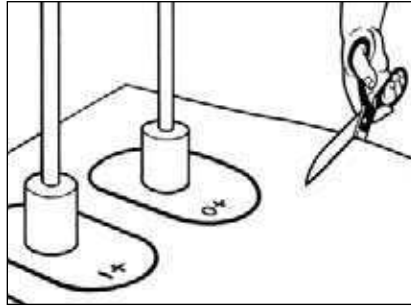

If your calibration sample is attached to the roll of membrane, cut it off.

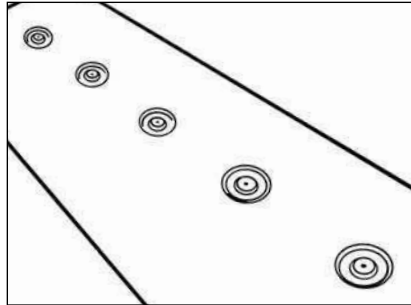

Remove the cooling clamps and turn membrane over to reveal the welded plates.

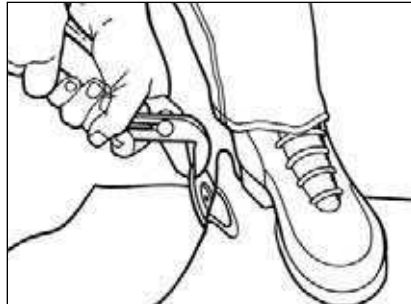

Use pliers to peel each plate off of the membrane.

Bond Results

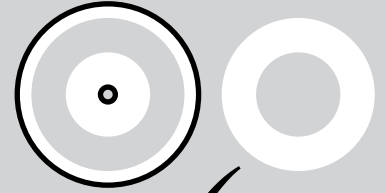

100% Bond ✓

Total, even, consistent adhesion of membrane. Plate makes a visible impression on the top of membrane.

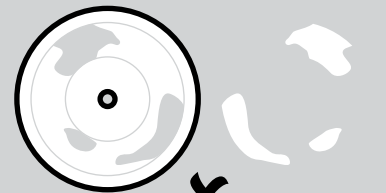

Partial Bond ✗

Uneven/incomplete adhesion of membrane. Energy setting may be too low, heat source may be off-center, or plate may be overdriven.

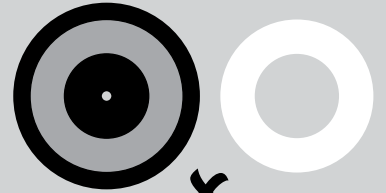

Excessive Heat ✗

Membrane may turn yellow, melt or become dimpled.

CALIBRATION TIPS

If a Low Voltage message appears in the RhinoBond display or if you do not get a 100% weld during calibration, check power at the end of the cord and determine what else is running on the same circuit.

Power output may be diminished if:

- The cord is too long.
- The power source is overloaded.

STEP 3: BOND THE MEMBRANE



Set tool to level that provides a 100% bond. Several settings may yield a 100% bond. If this happens, select the energy level setting in the middle. See previous page for example of optimal and undesirable bonds.

IMPORTANT TIP

Read **Additional Display Options** on page 8 for useful display messages and optional features before proceeding.

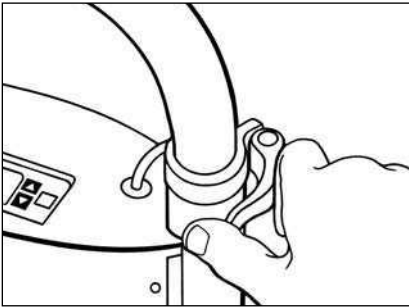

Adjust the handle height, if desired, by releasing handle clamps and gently pulling or pushing handle to desired position.

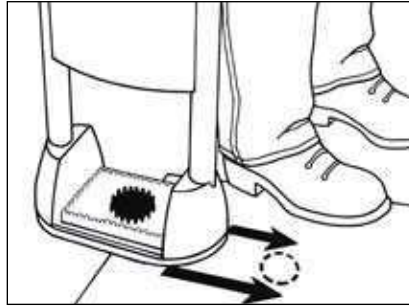

Center the calibrated RhinoBond tool over the first plate in pattern and activate the weld. **WARNING: Tool must be centered** over the plate to create a 100% bond. **If an error occurs during activation, refer to page 9 for corrective action.**

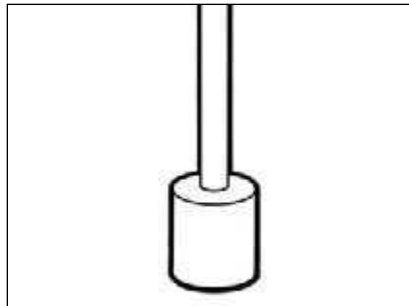

Place cooling clamp over the welded plate. **WARNING: Keep clamp in place at least 45 seconds** while the assembly cools.

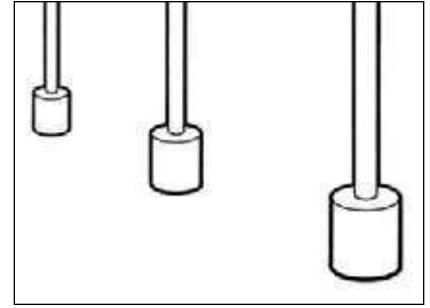

Repeat process for each plate.

IMPORTANT TIP

To increase your pace, work across the sheet, moving cooling clamps from one row to the next as you need them.

RhinoBond Weld Test

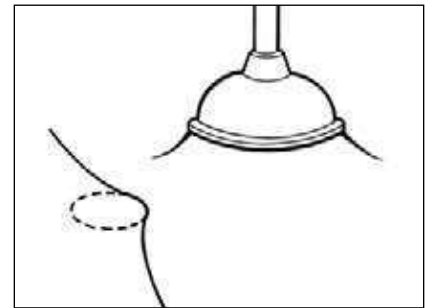

To determine if a weld has been made, place the plunger next to a welded plate and create enough suction to lift the membrane. A weld will create the membrane as shown. If the assembly is not welded, the membrane will lift up from the plate.

Mark any plates that are not welded as a reminder to complete the weld.

The RhinoBond Display

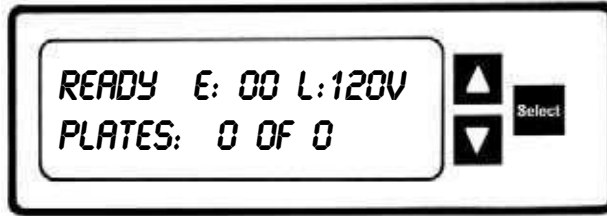

Display Functions



STARTUP SCREEN displays current RhinoBond software version for 30 seconds.

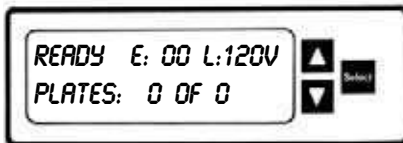

READY SCREEN displays energy level, power voltage and number of plate welds completed. At startup, energy and welds completed reads: 0.

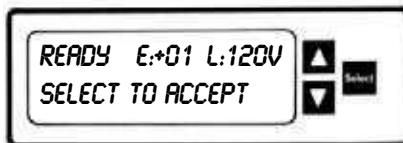

▲ AND ▼ increase or decrease energy setting one step at a time (+1 for more energy, -1 for less energy). Press **Select** to accept new setting.

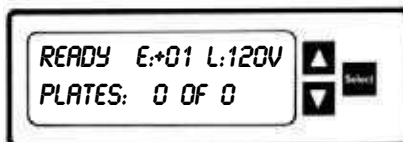

READY SCREEN returns once new energy setting is accepted.

Menu Options/Features

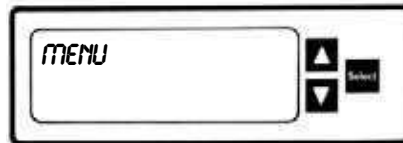

PRESS **Select** KEY to activate the Menu. Then press ▲ or ▼ to scroll through Menu options.

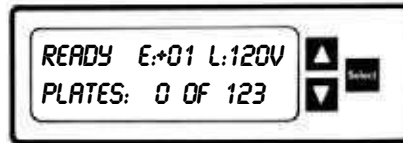
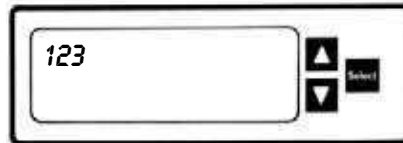

OPTION: ENTER # OF PLATES allows you to record the number of plates for the total job. Press **Select** to activate the option. Press ▲ or ▼ to enter the first digit. Press **Select** to accept and move to the next digit. Repeat until full number is entered and accepted. Press **Select** again to exit.





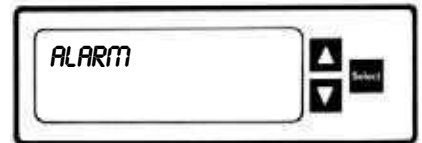

PLATES REMAINING allows you to view the number of plates which have not been welded for a particular job.

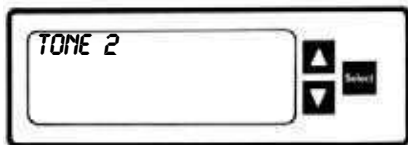
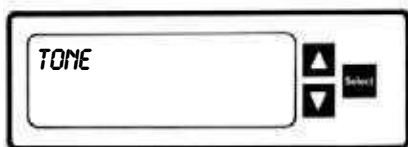

OPTION: SET ALARM activates an alarm that signals the end of a completed weld. Press **Select** to activate the option. Press ▲ or ▼ to choose Alarm On or Alarm Off mode. Press **Select** to accept the mode and exit.



OPTION: SET TONE offers two tone options, to help you distinguish between two RhinoBond units used in close proximity. Press  to activate the option. Press  or  to choose Tone 1 or Tone 2. Press  to accept the tone and exit.



OPTION: CYCLES TO DATE displays the number of cycles completed to date. Cycles are automatically recorded for maintenance and repair purposes. Press  to view Cycles to Date and again to exit.

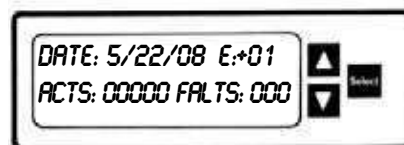

OPTION: VIEW LOG allows a foreman to review the date and details of each event/job. The energy level setting is displayed along with the number of Activations and Faults at the energy level used. Contact OMG for additional information when troubleshooting a job.

Error Messages

IMPORTANT

If an error occurs during activation, the display will indicate one of the following error messages.

Allow the target assembly to cool completely, check all connections, realign the tool, and activate the weld again. **WAIT AT LEAST 5 MINUTES BEFORE ATTEMPTING TO ACTIVATE THE WELD A SECOND TIME AFTER A FAULT.** The tool can be used to weld other assemblies while waiting for the assembly to cool.



LOW LINE VOLTAGE. CORRECT SOURCE: Check voltage at your source. Your power may be diminished if:

- **Your cord is too long**
- **Your power source is inadequate or overloaded**



HIGH LINE VOLTAGE. CORRECT SOURCE: Correct voltage at your source using an AC Line Voltage Regulator.



NO PLATE FOUND: RhinoBond tool is not centered properly over the plate.



OVERLOAD: RhinoBond senses excessive metal. The tool may be too close to the metal deck. Try activating the tool while it is pointed toward the sky.

The RhinoBond System Warranty

The RhinoBond System is guaranteed for 200,000 cycles of operation. During this period OMG, Inc., at its option, will repair or replace any tool for the first end-user. This will be done free of charge, provided the tool is determined defective in materials or workmanship upon examination by an Authorized RhinoBond System Service Technician.

This Warranty will be honored only if:

- A. No evidence of abuse, misuse or failure to follow safety or operating instructions, or improper maintenance or modification of the tool, is present. (Read Safety and Operating Instruction Manual for safe use and maintenance instructions.)
- B. When replacement is necessary, the first end-user returns the tool with transportation prepaid, to the nearest Authorized RhinoBond System Service Technician with purchase receipt or other positive proof of purchase.
- C. Only genuine RhinoBond tool and fasteners are used in the application.

THE FOREGOING WARRANTY IS IN LIEU OF ALL OTHER WARRANTIES. ALL OTHER WARRANTIES, WHETHER ORAL, WRITTEN, EXPRESS OR IMPLIED, INCLUDING BUT NOT LIMITED TO THE IMPLIED WARRANTIES OF MERCHANTABILITY AND FITNESS FOR A PARTICULAR PURPOSE SHALL NOT APPLY. THESE OTHER EXPRESS OR IMPLIED WARRANTIES ARE SPECIFICALLY EXCLUDED. BUYER'S OR USER'S REMEDIES ARE SOLELY AND EXCLUSIVELY AS STATED HEREIN. OMG, INC. SHALL IN NO EVENT BE LIABLE FOR INCIDENTAL, CONSEQUENTIAL, INDIRECT OR SPECIAL DAMAGES RESULTING FROM FAILURE OF THIS WARRANTY. IN NO EVENT, WHETHER AS A RESULT OF BREACH OF CONTRACT, WARRANTY, TORT (INCLUDING NEGLIGENCE) OR OTHERWISE, SHALL OMG, INC.'S LIABILITY TO THE BUYER OR USER OF THE TOOL OR ANY LOSS OR DAMAGE ARISING OUT OF THE BREACH OF WARRANTY, CONTRACT OR TORT, EXCEED THE PURCHASE PRICE HEREIN. ANY CLAIM OR LIABILITY SHALL IN ANY EVENT TERMINATE UPON THE EXPIRATION OF THE WARRANTY PERIOD SPECIFIED ABOVE.

OMG, Inc.
153 Bowles Road
Agawam, MA 01001
800-633-3800
www.olyfast.com

© 2011 OMG, Inc. All rights reserved.