

REEF INDUSTRIES, INC.

The Manufacturing Leader of Specialized Industrial Plastic Films Since 1957.



GRIFFOLYN[®] REINFORCED VAPOR PROTECTION ARCHITECTURE · ENGINEERING SPECIFICATION GUIDE



GRIFFOLYN[®] REINFORCED VAPOR PROTECTION

ARCHITECTURE · ENGINEERING SPECIFICATION GUIDE

DIVISION 7

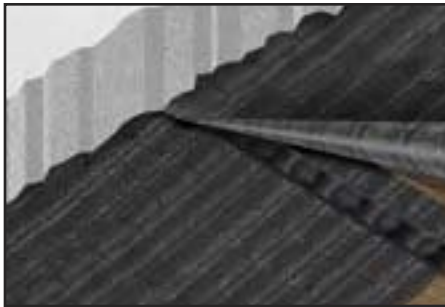

Slab Vapor Protection

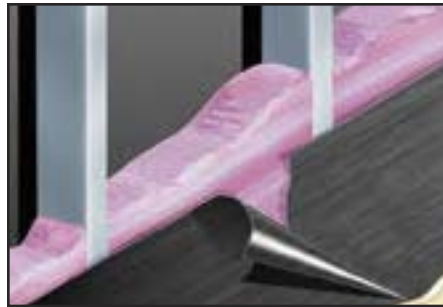

Wall Vapor Protection

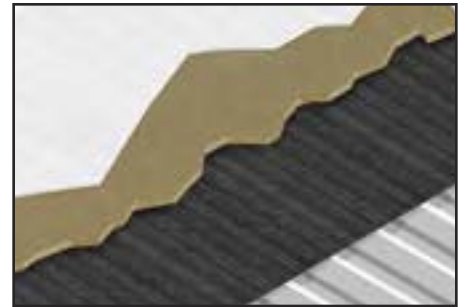

Roof Vapor Protection

TOLLFREE 1.800.231.6074
www.reefindustries.com

Enter dates of updated material received here.

(If it has been more than 12 months since an update has been received, please call 1.800.231.6074.)



Please send me updated information as it becomes available about Griffolyn[®] Vapor Protection products.

Name _____

Company _____

Phone _____ Fax _____

Address _____

City _____ State _____ Zip _____

Country _____ E-mail _____

GRIFFOLYN® REINFORCED VAPOR RETARDERS

UNDER SLAB WALLS ROOF DECKS



Protect Your Building Envelope From The Destructive Forces Of Nature

Assured System Performance

About Reef Industries

Does your structure require special consideration in terms of vapor control? Does your vapor control system require high performance materials and the expertise to properly implement them? If so, no company is better able to support your efforts than Reef Industries, the pioneer and industry leader in reinforced laminates and composites for vapor retarder applications.

Founded as the original division of Reef Industries in 1957, Griffolyn introduced a newly patented process to manufacture internally reinforced film laminates. The result was high strength, lightweight and ruggedly durable materials that offered easy to use and cost effective solutions to vapor control problems. The heavier and more tedious to install materials then in use, were rapidly replaced as Griffolyn systems became recognized as the state of the art technology.

Over the years, new technologies and innovations spawned a variety of new manufacturing techniques and product lines. The increasing scope and range of production capability encompassed additional product offerings and in 1976, the corporate identity of Reef Industries, Inc. was adopted.

Reef Industries is headquartered in Houston, Texas and operates six product divisions including Griffolyn. A state-of-the-art manufacturing facility and two fabrication plants support a worldwide sales network. Technical support and research groups, staffed by knowledgeable engineers and chemists, work closely with the most experienced sales department in the industry. This team is uniquely qualified to provide extensive support services to Griffolyn specifiers and customers.

CONTACT INFORMATION

Reef Industries, Inc.

9209 Almeda Genoa Rd.

Houston, TX 77075

Toll-Free: 1-800-231-6074

Phone: 713-507-4251

Fax: 713-507-4295

Email: ri@reefindustries.com

www.reefindustries.com

CONSIDERATIONS FOR DESIGNERS AND SPECIFIERS

Moisture Problems in Buildings

Each year, countless building owners suffer the problems associated with material and systems failures due to moisture. Anyone who has faced a shutdown or limited use of their facility due to a wall system, roof assembly or flooring failure can attest to the cost and inconveniences involved. There is much to motivate design professionals to utilize every available means to avoid and minimize the potential for these problems:

- Inconvenience to the owner/client
- Monetary loss from disrupted operations
- Bad publicity
- High repair costs
- Adverse effects on indoor air quality
- Design liability exposure and litigation
- Potential impact on "Errors and Omissions" insurance premiums

Water Vapor Migration

One of the primary functions of the building thermal envelope is to maintain desirable temperature and humidity for occupant comfort. Within the range of temperatures encountered in buildings, water may exist as a vapor, liquid or solid.

Moisture-related problems in buildings may arise from:

1. The presence of too much moisture
2. Changes in moisture content
3. Effects of a change of state, such as freezing within wall cavities
4. Deterioration of materials due to corrosion of metals, or rotting of wood framing

In the design, specification and construction of the building envelope, the behavior of moisture must be considered, particularly the occurrence of condensation. Problems may arise when moisture comes into contact with a cold surface such as a window, or within outdoor walls or roof-ceiling assemblies. Condensation within walls that enclose air conditioned spaces must be considered in warm humid climates.

Moisture moves in air due to differences in vapor pressure, but also with movement of the air itself. The causes of air motion through construction assemblies must be considered, especially infiltration and exfiltration at windows, doors and other penetrations of the building envelope.

Vapor Retarders and Air Barriers

Most building materials are permeable to moisture. Porous materials that become saturated with moisture lose their insulating ability and may not regain it when dry. Walls are particularly susceptible, and moisture migration should be prevented or minimized by use of low permeance membranes, called vapor retarders (formerly referred to as vapor barriers). A vapor retarder is a material that has a flow rating of one perm or less (1 perm = 1 grain/hr-ft²-in Hg vapor pressure difference). Permeability of one perm is often still too high for a vapor retarder to be effective in most building applications. A lower permeability rating is generally required. As a general rule, vapor retarders should be installed as close as possible to the side of the assembly through which moisture enters. Air barriers are designed to stop the movement of air, which can cause not only convective heat flow, but movement of large volumes of moisture along with the air.

Permeability, Strength, Durability, Fire Retardancy

Low permeability, high strength, and durability are the primary selection and specification criteria. Additionally, building code provisions may sometimes require use of materials which are fire retardant. Vapor retarders should be selected according to their intended performance, as determined by recognized, industry standard test methods.

The investment made in selecting and specifying an effective vapor retarder system during the design and construction process are only pennies per square foot. The cost of corrective measures required by improperly installing a vapor retarder, installing the wrong vapor retarder, or not installing one at all, has proven to be many dollars per square foot.

NOTES TO SPECIFIER: Careful placement and sealing of vapor retarder materials is essential to ensure effective moisture vapor control. Perforation of the membrane for any reason will limit its effectiveness and can be responsible for failure at the time of installation. The use and placement of vapor retarders should be determined by a qualified design professional familiar with their use, and with local climatic conditions. In no case should two non-permeable materials be used in the same assembly since moisture could be trapped between them, resulting in extensive damage. By design, Griffolyn Vapor Retarders are not "breathable" (vapor permeable) and are not appropriate for use where breathable materials are required.

THE GRIFFOLYN® SYSTEM

Griffolyn® Vapor Retarder Materials

The main components of the Griffolyn system are several grades of high performance polyethylene vapor retarder material made of HDPE (high density polyethylene), LDPE (low density polyethylene), or LLDPE (linear low density polyethylene). They are reinforced with a heavy-duty polyester cord grid for high strength and durability. Vapor retarders can be manufactured in sizes to meet project requirements up to 200 feet x 200 feet (61 m x 61 m), greatly reducing the number of in-field seams and the potential for failure.

Fab Tape™

Fab Tape is an asphaltic mastic which creates a durable field seam between multiple vapor retarder sections and for sealing around penetrations. Proper installation is imperative to ensure optimal bonding and sealing.

Fab Tape Application

Both Griffolyn surfaces must be clean and dry. On a dirty surface the tape will adhere to sand and dust instead of the Griffolyn Vapor Retarder Material. If the surface is wet, pockets of moisture are created which can thermally expand and contract, degrading adhesion and destroying the seal.

Warm temperatures promote better initial adhesion. Fab Tape will reach maximum bond strength in about 24 hours when ambient temperatures exceed 60°F (15°C). In ambient temperatures below 60°F (15°C), longer bonding times should be expected, unless supplemental heat is applied.

Proper grading of the subgrade beneath the vapor retarder is essential for optimal sealing. A rough, rutted or lumpy sub-grade can cause wrinkles and gaps which make it difficult to achieve an effective bond.

Placement of Fab Tape during installation.

Lay both vapor retarder sections over a smooth surface with a 6 inch (150 mm) overlap. Fold the top section back and apply the Fab Tape 4 inches (100 mm) back and parallel to the edge of the bottom section. Smooth out any gaps or voids while applying the tape. Remove the release paper and firmly press the top section to the bottom while maintaining even tension to avoid gaps which could cause leaks. Allow adequate time for complete bonding before subjecting the seam to substantial stress.

Griff Tape™

Griff Tape is a self-adhesive tape used to repair holes in the vapor retarder caused by jobsite damage. The tape helps to assure an effective seal around the building envelope.

Pipe Boots

The application of pipe boots helps to maintain the integrity and performance of the vapor retarder system. Pipe boots are available in several sizes compatible with Griffolyn Vapor Retarder Materials.

Installation of pipe boots. Attach Fab Tape around perimeter of the boot and remove the backing paper. Be sure the ends of the tape overlap each other. Lower the boot over the pipe and press the boot material firmly to the vapor retarder material around the pipe. Lower the tube section and wrap Fab Tape around the pipe. Place the tape to allow some slack when the boot is raised above the tape. Remove backing paper. Raise the tube section and secure over tape. (See special instructions for Type-65G.)

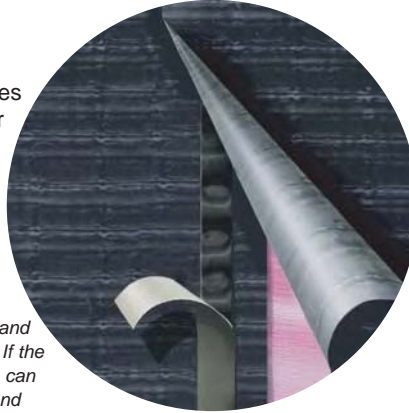

Transguard® 4000

The American Concrete Institute (ACI) recommends maintaining satisfactory moisture content during concrete curing for best results. Lack of sufficient moisture may cause cracking, dusting, scaling and crazing. Transguard 4000 is a strong, lightweight, re-usable, wet-cure cover with a high water retention rate that helps maintain appropriate moisture levels during the concrete curing process. Transguard 4000 is totally synthetic to avoid concrete staining common to other covers.

NEW ENVIRONMENTAL CONSIDERATIONS

Indoor Air Quality An important issue receiving a lot of attention lately is the subject of so-called "sick building syndrome". It can have many causes including dangerous molds, bacteria, mildew, gasses given off by building materials, and inadequate ventilation. Indoor air quality (IAQ) problems don't just make a building "sick"; they also carry with them a high degree of human health risk. There is growing evidence that many of these problems are made worse, if not caused by, unwanted moisture in buildings. Much of this moisture enters through exterior walls and floor slabs. Mold, mildew, and other organisms feed on organic materials in the building. They often flourish in wall cavities and in the dark, moist environment under flooring materials and carpeting.

Radon Control Radon gas is a naturally occurring by-product of the decay of uranium in the soil. It can enter buildings through cracks in foundation walls and floor slabs. High levels of radon in buildings have been linked to increased risk of lung cancer. The use of vapor retarders can effectively reduce the amount of radon entering a building when used as part of a complete radon control system.

Crawlspace Moisture One of the leading sources of health related problems and moisture related damage to a home is caused by ventilated dirt crawlspaces. Ventilated dirt crawlspaces provide a source of moisture that can lead to mold, mildew, fungus and even structural wood damage. It has been shown that unvented and conditioned crawlspaces with an effective crawlspace membrane provide better moisture control than vented crawlspaces.

Non-solvent Flooring Adhesives

Effective Jan. 1, 1996 chlorinated solvents that have been a part of flooring adhesives for many years could no longer be manufactured in the United States. Adhesive manufacturers now use either water-based or "100% solids" formulations. A disadvantage of these formulations is that they may re-emulsify in the presence of water penetrating the floor slab from below, causing the floor system to fail prematurely.

Flooring materials have changed, too. Materials such as vinyl asbestos tile (VAT) which were "breathable" have been replaced by vinyl composition tile (VCT) which is not vapor permeable. These materials are highly susceptible to failure from condensation forming underneath the floor covering. An effective vapor retarder below concrete slabs is now more important than ever.

SOURCES OF VAPOR RETARDER PROBLEMS

By understanding some of the pitfalls surrounding the effective installation of vapor retarders, specifiers can head off potential problems and failures. Contractors must install vapor retarder systems correctly by following the project specifications and the manufacturer's installation recommendations. Some of the most common problems of vapor retarder systems include:

1. Placing concrete on a vapor retarder rather than an absorptive base such as sand or gravel increases the water "bleeding" period. Concrete finishers sometimes poke holes in the vapor retarder to allow water to disperse so they can start work sooner.
2. Workers often puncture the vapor retarder with stakes while placing edge forms and reinforcing bar supports.
3. Vehicular traffic before and during concrete placement can rip thin, non-reinforced plastic sheets or cause underlying sharp aggregate to make thousands of tiny perforations in the vapor retarder material.
4. Unsealed openings may occur along lapped edges of the vapor retarder, at intentional penetrations for pipes, conduits, outlet boxes and at the floor-wall intersection. The vapor retarder should be pulled up and sealed to the footing or foundation wall.

UNDER SLAB APPLICATIONS

Natural soil capillarity can allow large volumes of moisture to contact the underside of a slab. Properly formed capillary breaks within the soil foundation system, combined with a high performance vapor retarder, are the first lines of defense. Without an under slab vapor retarder, moisture can be forced upwards under pressure into habitable space. Mineral salts from the ground and from the concrete itself can be transported through the slab to the underside of the flooring system causing visible efflorescence and staining.

Some of the problems commonly associated with moisture migration through the slab include:

- Deterioration of flooring adhesive
- Bumps, ridges or bubbles under flooring
- Color changes
- Mold, mildew and bacteria growth
- Peaking, curling, or warping of flooring
- Efflorescence (build-up of mineral salts)

The majority of flooring failures result directly from a high emission of moisture from the concrete slab. It is said that moisture is the largest single problem in the flooring and coated surfaces industries today.

Many of the vapor retarders installed under building slabs do not perform adequately due to improper placement or puncturing. Ineffective vapor retarders will not reduce permeability enough to control even the small amount of moisture it takes to interfere with the bond integrity of modern flooring systems.

The need for an under slab vapor retarder in high humidity areas with high water tables is well understood. However buildings in arid climates also need vapor retarders.

Air conditioning the interior of the structure creates a significant difference in vapor pressure which can cause moisture to be drawn out of the ground (an area of relatively high vapor pressure) through the slab and into the space above (an area of low vapor pressure). Landscape irrigation systems, planters, broken plumbing pipes and other water sources can lead to moisture problems, even in arid regions.

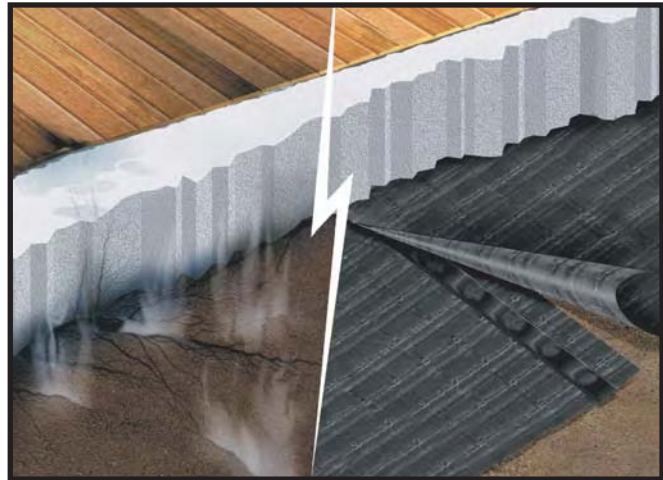

The majority of flooring failures result directly from a high emission of moisture from the concrete slab. Slab moisture is the largest single problem in the flooring and coated surface industries today. The low permeance and high strength of Griffolyn under slab vapor retarders effectively control under slab moisture infiltration, preventing expensive flooring failures.

All major flooring manufacturers have specifications

requiring moisture tests before installation of their flooring materials. Even if new concrete is allowed to dry to the point where flooring can safely be installed, the absence or improper installation of a vapor retarder can lead to expensive failures later. Research into moisture-related flooring failures has shown a high correlation between the severity of the failure and the absence of a vapor retarder. Buildings without a vapor retarder will not necessarily have moisture problems. However, buildings with vapor emission problems are usually found to have inadequate vapor retarders.

There are two ASTM standards for vapor retarders under concrete slabs, ASTM E-1745-97 "Standard Specifications for Water Vapor Retarders Used in Contact with Soil or Granular Fill Under Concrete Slabs". ASTM E-1745-97 list three classifications which may be used to specify vapor retarders. The second standard is ASTM E-1643-98 "Standard Practice for Installation of Water Vapor Retarders Used in Contact with Earth or Granular Fill Under Concrete Slabs". (See the Product Description & Application Selector Guide)

WALL APPLICATIONS

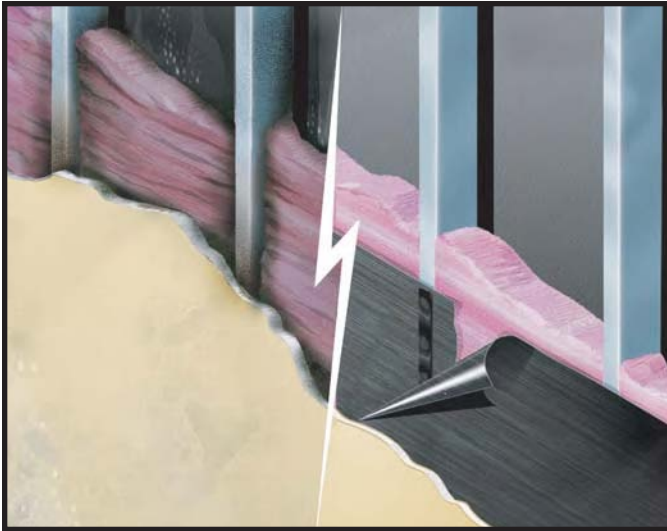

Moisture Infiltration in wall cavities can result in mold and decay problems. Damaging moisture is introduced into wall cavities through air leaks and vapor diffusion. Griffolyn vapor retarders effectively control moisture infiltration into the building envelope.

“Caution: Do not rely on sheet polyethylene as a primary vapor retarder. During temperature cycling and exposure to air, polyethylene deteriorates and cracks resulting in an ineffective seal.”

SpecGUIDE 07190 - Vapor Retarders
The Construction Specification Institute (CSI)

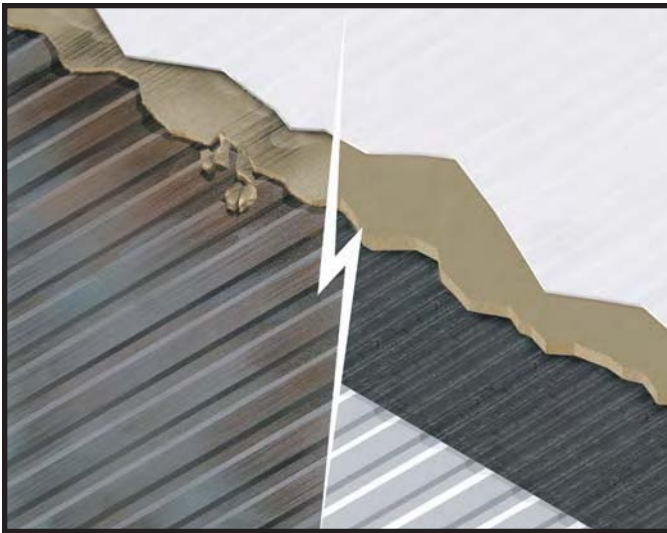

Moisture in the roof assembly can cause structural corrosion, staining, mold and mildew growth and saturated insulation. A Griffolyn vapor retarder system can stop water vapor from causing loss of insulation performance, structural damage and other moisture-related problems.

Fire retardant vapor retarder materials may be required by building codes. Consult the building code authority having jurisdiction for more information.

Properly protecting the building envelope from mold and degradation caused by moisture infiltration usually requires the use of a vapor retarder in wall assemblies. This is especially true in regions where there is a substantial difference between inside and outside moisture levels, which can create a large vapor pressure differential.

Moisture is introduced into walls through both air leaks (convection) and vapor diffusion. Of these two methods, air leaks present a greater potential for causing moisture damage. It is estimated that air leakage through a hole of less than one square inch can allow passage of up to nearly eight gallons of water into the building envelope over the course of a single heating season. A high quality vapor retarder might be able to eliminate condensation caused by diffusion, but even an excellent vapor retarder is of little use if it can be bypassed by convective currents.

Griffolyn vapor retarders effectively control air leaks and vapor diffusion to reduce the amount of moisture infiltration into the building. The effectiveness of the vapor retarder will be greatly affected by the number of penetrations through the material made during installation. All penetrations should be sealed with a pipe boot, Fab Tape, or Griff Tape before finishing the wall.

The location of a Griffolyn vapor retarder in the structure depends upon whether the building is to be located in a predominantly heating climate or cooling climate. The concept is to keep the vapor retarder on the warm side of the dew point to prevent condensation on cold surfaces inside the wall. The same consideration applies when placing vapor retarders in roof deck assemblies. For design standards and more information, consult the ASHRAE “Handbook of Fundamentals” published by The American Society of Heating, Refrigeration and Air Conditioning Engineers.

ROOF APPLICATIONS

Some buildings generate large amounts of moisture as a result of activities or processes they contain. Examples include natatoriums, manufacturing facilities, certain industrial processes and food plants. As a result of condensation which can occur within the roof assembly, these buildings may experience problems with saturated insulation, structural corrosion, staining, mildew growth, and other moisture-related problems.

An effective vapor retarder system located on the warm side of the dew point can stop water vapor from reaching a temperature or location where it can cause loss of insulation performance or serious damage. For many years the National Roofing Contractors Association (NRCA) has maintained that vapor retarders should be considered for use in low-slope membrane roof assemblies where:

- The outside average January temperature is below 40 degrees F (4°C), and the expected interior winter humidity is 45% or greater.



ASHRAE has also developed design criteria for low sloped roofs. Consult their “Handbook of Fundamentals” for methodology on use of vapor retarders. NRCA recommends that when ASHRAE guidelines are followed, the vapor retarder:













































- permeability rating should approach 0 perm
- should be completely sealed at side and end laps
- should be sealed and flashed at all roof perimeters and penetrations
- should envelope the vertical edges of insulation boards
- must be able to resist damage from hot asphalt or specified adhesives
- should be chemically compatible with conventional roofing materials
- may need to have good adhesion and shear properties

PRODUCT DESCRIPTIONS

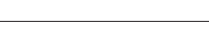

Vapor Retarder Products

Griffolyn® Type-65	Griffolyn® Type-85	Griffolyn® Type-105
Type-65 is a reinforced 3-ply polyethylene, general purpose vapor retarder which meets the strength and permeance requirements for most applications.	Type-85 is a reinforced 5-ply vapor retarder which offers greater strength and lower permeance for a higher level of integrity in under slab and roofing applications.	Type-105 is a reinforced 7-ply vapor retarder which is engineered to deliver the extra strength and extra low permeance needed to meet the additional requirements of wood flooring, special coatings and special flooring systems.
		

07220	Roof & Deck Insulation			
07410	Metal Roof & Wall Panels			
07420	Plastic Roof & Wall Panels			
07460	Siding			
07500	Membrane Roofing			
07610	Metal Roofing			
09250	Gypsum Board			
09500	Ceilings			
09620	Specialty Flooring			
09640	Wood Flooring			
09650	Resilient Flooring			
09660	Static Control Flooring			
09670	Fluid Applied Flooring			
09680	Carpet			
09950	Wall Coverings			

NEW PRODUCTS!

Standard Specification for Water Vapor Retarders Used
in Contact with Soil or Granular Fill Under Concrete Slabs.

“ASTM E-1745-97 REQUIREMENTS”

Criteria	Test Method	Class A	Class B	Class C
Water Vapor Permeance	ASTM E-96	0.3 perms	0.3 perms	0.3 perms
Tensile Strength	ASTM D-882	45.0 lbf/in	30.0 lbf/in	13.6 lbf/in
Puncture Resistance	ASTM D-1709 Method B	2200 grams	1700 grams	475 grams











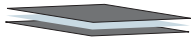





































“GRIFFOLYN VAPOR RETARDER PERFORMANCE”

Criteria	Test Method	15 mil GREEN	10 mil GREEN
Classification		Class A	Class A&B
Water Vapor Permeance	ASTM E-96	0.018 perms	0.027 perms
Tensile Strength	ASTM D-882	58 lbf	45 lbf
Puncture Resistance	ASTM D-1709 Method B	3100 gm	2270 gm

& APPLICATION SELECTOR GUIDE

07 26 00/GRI
BuyLine 3575

Fire Retardant Products

Griffolyn® VAPORguard®	Griffolyn® Type-65G	Transguard® 4000	Griffolyn® Type-55 FR	Griffolyn® TX-1200® FR	Griffolyn® Type-90 FR
VAPORguard is specifically engineered to combine high density polyethylene and aluminum to provide an extremely low permeance for special applications such as radon protection, cold storage, museums, and computer rooms.	Type-65G combines the high performance of Griffolyn high density reinforced polyethylene with a non-woven geotextile for an under slab vapor retarder with superior puncture resistance.	Transguard 4000 Concrete Curing Covers have a higher moisture retention than burlap, requiring less frequent re-wetting which helps to maintain the correct moisture level for proper concrete curing.	Type-55 FR is a reinforced 3-ply general purpose fire retardant vapor retarder for use in walls, ceilings and roof assemblies.	TX-1200 FR is a reinforced 3-ply vapor retarder which offers greater strength and lower permeance. Qualifies as a Class I building product for a higher level of integrity in walls, ceilings and roof assemblies.	Type-90 FR is a reinforced 5-ply vapor retarder which is engineered to deliver the extra strength and extra low permeance required in applications with extreme temperature variation.
					
					
					
					
					
					
					
					
					
					
					
					
					
					
					
					

NOTES TO SPECIFIER: When specifying products from the above CSI Master Format sections, please consult the specific product manufacturer regarding their requirements for vapor retarders. Some manufacturers require the presence of a vapor retarder before they will warrant their product.

“SURFACE BURNING CHARACTERISTICS”

Griffolyn Type-55 FR, TX-1200 FR and Type-90 FR pass NFPA 701 Large Scale “Standard Methods of Fire Tests for Flame-Resistant Textiles and Films.” They have a Class I / Class A Flame Spread Rating per UBC-42 and ASTM E-84.

Product	Flame Spread	Smoke Developed
Type-55 FR	10	70
TX-1200 FR	10	45
Type-90 FR*	5	135

* Class II / Class B

Physical Properties & Typical Values

ASTM D-3776 / Weight

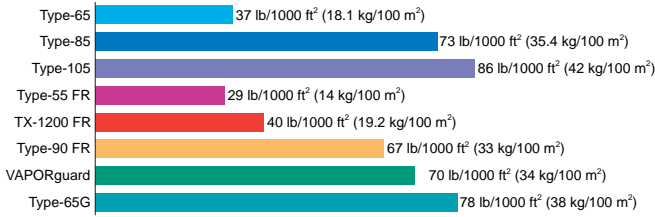

D-3776 is the procedure used for calculating the weight of the material.

ASTM D-2582 / Puncture Propagation Tear

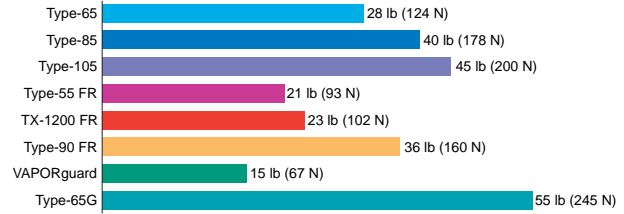

D-2582 determines the dynamic tear resistance of the material when subjected to end-use snagging-type hazards.

ASTM E-96 / Permeance (PERM)

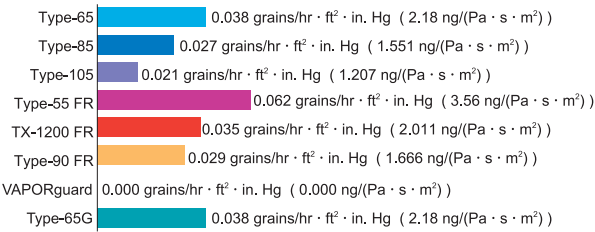

E-96 determines the rate at which water vapor passes through a material 73.4° F, 50% RH

ASTM D-1709 / Puncture Resistance

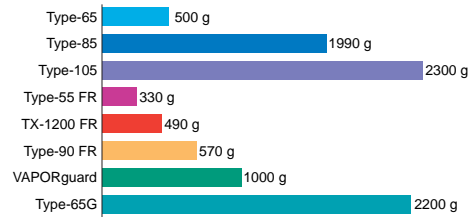

D-1709 determines the performance of the material when impacted by an object.

ASTM D-882 / 3" Tensile Strength

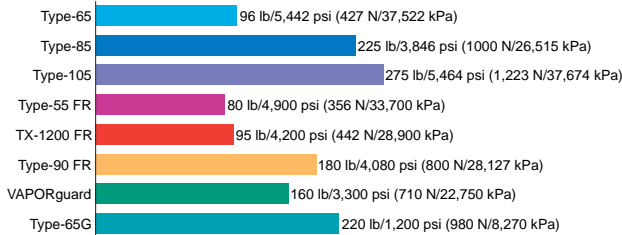

D-882 measures the ability of the material to resist a tensile-type load.

ASTM D-4833 / Puncture Strength

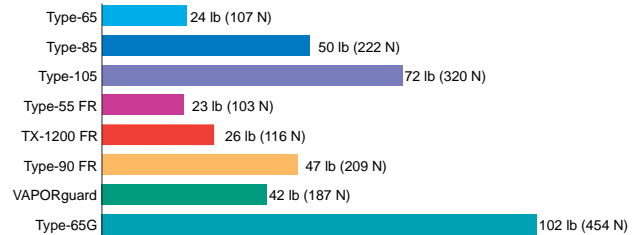

D-4833 measures the ability of the material to resist punctures.

Units in parentheses are metric for compliance on government projects.

Call Today for Samples and Specification Guide

1-800-231-6074



9209 Almeda Genoa Rd.
Houston, TX 77075

Phone: 713-507-4251 Fax: 713-507-4295

www.reefindustries.com

email: ri@reefindustries.com

The information provided herein is based upon data believed to be reliable. All testing is performed in accordance with ASTM standards and procedures. All values are typical and nominal and do not represent either minimum or maximum performance of the product. Although the information is accurate to the best of our knowledge and belief, no representation of warranty or guarantee is made as to the suitability or completeness of such information. Likewise, no representation of warranty or guarantee, express or implied, or merchantability, fitness or otherwise, is made as to product application for a particular use.

Standard Specification for Water Vapor Retarders Used in Contact with Soil or Granular Fill Under Concrete Slabs.

ASTM E-1745-97

Permeance
ASTM E-96 (B)
(ASTM E-154 Section 7)

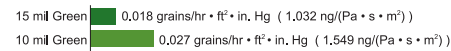

Tensile Strength
ASTM D-882
(ASTM E-154 Section 9)

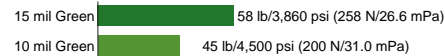

Puncture Resistance
ASTM D-1709
Method B



03 39 00/ARM
Buyline 2812

ARMORLON[®]
DIVISION OF REEF INDUSTRIES, INC.



Transguard[®] 4000
Reusable Wet Curing Covers

About Reef Industries

Does your project specify wet curing control? The American Concrete Institute recommends maintaining a satisfactory moisture content for the best concrete curing results. Lack of sufficient moisture during the curing process can cause cracking, dusting, scaling and crazing. Transguard® 4000 provides an effective way to maintain appropriate moisture levels during curing. No company is better able to support your efforts than Reef Industries, the pioneer and industry leader in reinforced laminates and composites for concrete curing control and vapor retarder applications.

Armorlon products offer the durability and strength of canvas but possess the flexibility and ease of handling of a far lighter material. Transguard 4000 is a concrete curing control material for both field and pre-cast applications. Armorlon, where value and performance go hand in hand.

Reef manufacturing and fabrication encompasses a host of different production processes, equipment and machinery housed in three plants.

The foundation of all Reef products is film. Extruded via the most advanced technology and equipment available, films are formulated to possess performance characteristics necessary to a broad spectrum of downstream products. Intermediate conversions such as lamination, printing, slitting, coating and treating take place in preparation for finished goods fabrication. Fusion welding, heat sealing, sewing and a variety of special or proprietary techniques take place in two modern fabrication plants and produce finished goods for a diverse array of industries.

Reef Industries Inc. offers the most experienced and capable sales staff in the industry. Among our sales managers exist nearly 120 years experience with Reef and an average tenure of more than 10 years. That kind of stability says something about a company and how it serves its customers. We're proud of our reputation and hope to share that experience with you.

CONTACT INFORMATION

Reef Industries, Inc.

9209 Almeda Genoa Rd.

Houston, TX 77075

Toll Free 1-800-231-6074

713-507-4251 Fax: 713-507-4295

Email: ri@reefindustries.com

www.reefindustries.com

Product Description & Application:

Transguard® 4000 is a natural polypropylene non-woven fabric with a white polyethylene backing that allows for proper moisture control during the concrete curing process, reducing cracking, dusting and scaling. The lightweight, reusable wet cure covers are more flexible than other curing materials, resulting in much easier installations, that save time, labor and money.

Transguard® 4000 features exceptionally low permeability and will retain water to permit the concrete to achieve maximum expansion. Transguard is available in stock sizes and also custom fabricated sizes to meet the requirements of nearly any application, including specialized bridge support columns and caps, as well as flatwork pavement projects.

Features & Advantages

- Easily handled-Fewer people can install in less time.
- Low permeability-Superior water retention; reduces amount of rewetting.
- Reflective-Reflects heat to decrease moisture loss.
- Reusable-Synthetic material; will not rot or deteriorate like burlap.
- Seals easily and effectively at edges and overlaps.
- Does not produce brown stains or affect the appearance of concrete.
- Allows for light traffic during the curing process without damaging the concrete.
- Stock sizes available for immediate shipment.
- Complies with AASHTO Specification M-171 for reflection and moisture retention and is D.O.T. approved in most states.

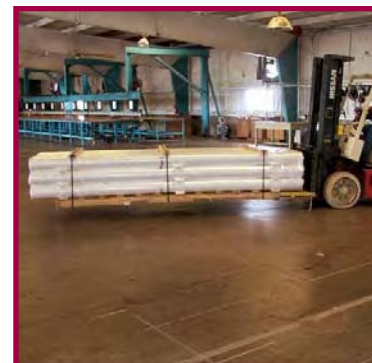

Transguard® 4000 Installation Instructions:

03 39 00/ARM
Buyline 2812

The material must be applied with the white polyethylene side up, so that moisture will entirely cover the full span of the deck. The blankets should be placed so that adjoining blankets overlap at least 6". All laps and outside edges shall be weighted to prevent displacement of blanket before curing is completed. Weighting and overlapping should be performed so as to ensure intimate contact between the blanket and concrete surface. Transguard® 4000 should be soaked thoroughly on the non-woven synthetic side, re-wetting when necessary may be performed by the use of a soaker hose or equivalent.

Transguard® 4000 is used for various applications, and care should be taken to keep a check for proper moisture retention.

Stock is available in these two convenient sizes: 24'x100' and 12'x100' rolls.



Wet the exposed concrete.



Apply Transguard® curing covers.



Place Transguard® covers so they lay flat, with a minimum 6" of overlap.



Check daily for proper moisture content.



Refer to project specifications for the required curing period.



Re-wetting may be performed by the use of a soaker hose or equivalent.



Transguard's superior water retention reduces the amount of re-wetting.

Transguard® 4000

Reusable Wet Curing Covers

Physical Properties & Typical Values

Transguard 4000 consists of a natural colored polypropylene non-woven fabric with a white polyethylene coating applied to one side. The non-perforated white coating contains ultraviolet light stabilizers providing protection against UV degradation.

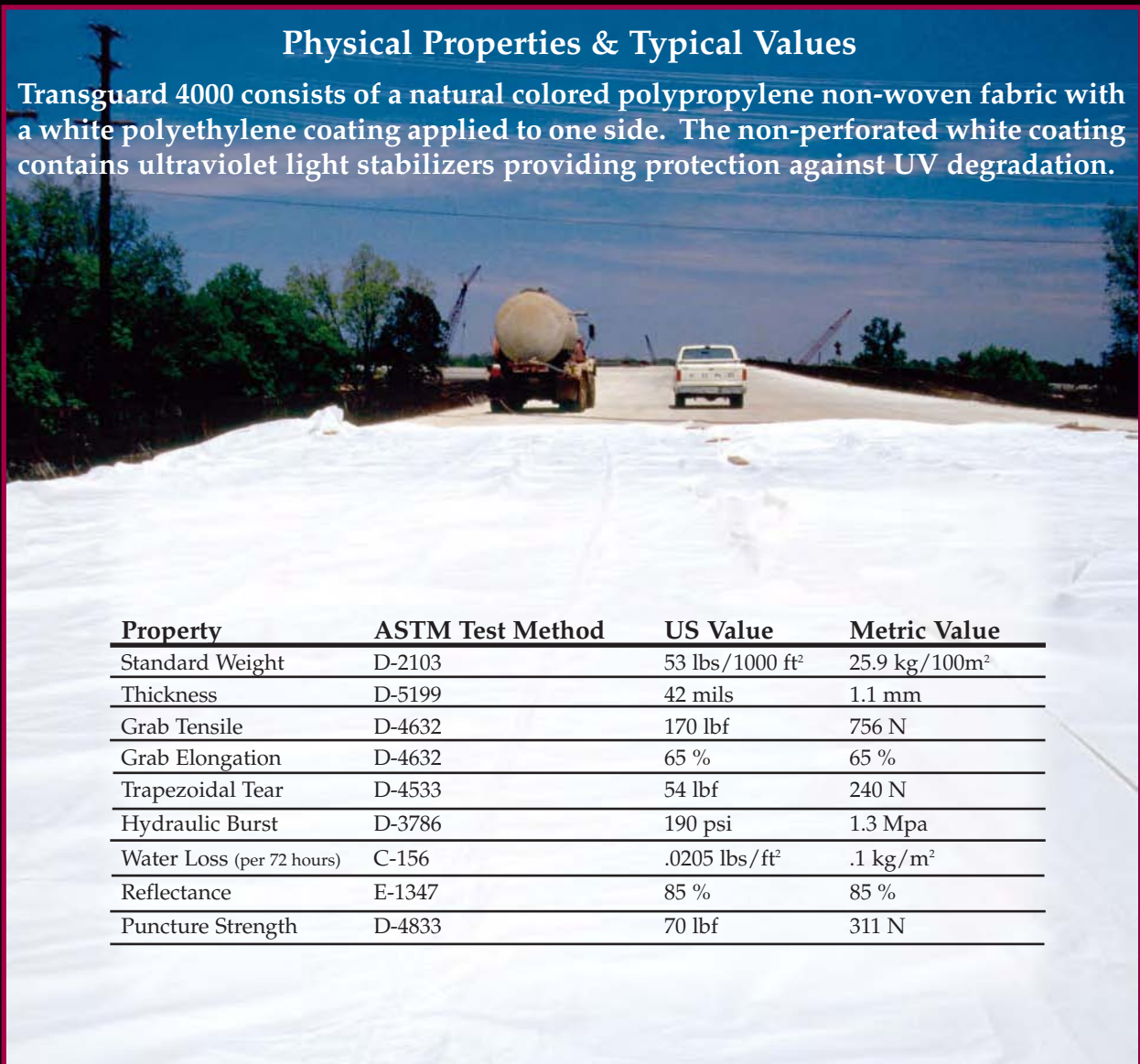

Property	ASTM Test Method	US Value	Metric Value
Standard Weight	D-2103	53 lbs/1000 ft ²	25.9 kg/100m ²
Thickness	D-5199	42 mils	1.1 mm
Grab Tensile	D-4632	170 lbf	756 N
Grab Elongation	D-4632	65 %	65 %
Trapezoidal Tear	D-4533	54 lbf	240 N
Hydraulic Burst	D-3786	190 psi	1.3 Mpa
Water Loss (per 72 hours)	C-156	.0205 lbs/ft ²	.1 kg/m ²
Reflectance	E-1347	85 %	85 %
Puncture Strength	D-4833	70 lbf	311 N

The information provided herein is based upon data believed to be reliable. All testing is performed in accordance with ASTM standards and procedures. All values are typical and nominal and do not represent either minimum or maximum performance of the product. Although the information is accurate to the best of our knowledge and belief, no representation of warranty or guarantee is made as to the suitability or completeness of such information. Likewise, no representation of warranty or guarantee, express or implied, or merchantability, fitness or otherwise, is made as to product application for a particular use.



9209 Almeda Genoa Rd.
Houston, TX 77075
713-507-4251 Fax: 713-507-4295
email: ri@reefindustries.com

Call Today for Samples and Specification Guide

800-231-6074

www.reefindustries.com

CRITICAL VAPOR BARRIER APPLICATIONS: A Total System Approach

Provided by the Griffolyn Division of Reef Industries, Inc.

While vapor barriers are a prudent precaution on any project to avoid costly moisture infiltration problems, there are a number of project types where the implementation of a vapor barrier system is imperative. Some projects such as gymnasiums present a greater need for reliable moisture protection due to the delicate precision and high susceptibility to moisture damage of hardwood floor components. Others such as natatoriums, cleanrooms and cold storage facilities create unique problems because of the high humidity and exaggerated differences in temperature and vapor pressure between the exterior and interior. In addition, environmental conditions such as a high water table or climate can produce moisture infiltration worries if the building is not protected by a properly installed vapor barrier system. The three primary characteristics to consider when specifying a vapor barrier for critical applications are permeance, strength & durability and efficiency of installation.

The amount of moisture vapor that can pass through the membrane (permeance) is especially important in applications where there will be a substantial interior/exterior difference in temperature, humidity or vapor pressure. Many "solid" building materials such as wood, brick, concrete or gypsum board offer little moisture protection due to their porous nature and require vapor barriers in such critical applications.

Without proper installation, the permeance and strength of the material are of little consequence. Moisture will flow through gaps in seams and around pipe penetrations just as readily as it does through tears in the membrane.

Griffolyn® reinforced vapor barriers utilize a total system approach to providing effective protection against moisture infiltration. There are several levels of permeance to choose from to meet the specific project demands for roofing, wall & ceiling and underslab applications. The high strength of the Griffolyn reinforced membrane helps ensure that field performance is consistent with the lab-tested perm rating.

The strength of the total system approach is most evident in the installation process. The most effective way to minimize moisture transmission through leaking field seams is to eliminate the seams altogether. Griffolyn vapor barriers are custom manufactured to fit almost any job with a single membrane. In cases where the job site is irregularly shaped or too large to make a single membrane practical, the multiple membranes can be easily and effectively sealed together with Fab Tape. This is a specially formulated sealing material that ensures an effective water and vapor tight system.

Almost every construction site has pipes and other obstructions that must penetrate the vapor barrier. Often a hole is simply cut in the membrane to allow the pipe to pass through the material. Water vapor can also pass through if the hole is left unsealed. The Griffolyn vapor barrier system provides specially designed pipe boots to effectively seal around every



The high susceptibility of hardwood floors to moisture damage can be offset through the proper installation of a vapor barrier system under the slab.



The effects of high humidity and exaggerated differences in interior/exterior vapor pressures associated with indoor pools can be controlled with an effective vapor barrier system.

penetration in the material.

Reef Industries, Inc., has been manufacturing and fabricating specialized industrial plastics since 1957. Reef is taking a proactive role in the architectural industry by working with ASTM and ACI committees to help bring meaningful standards to this historically fragmented industry. In addition, the R&D department is constantly working on ways to incorporate the latest technological advances with time-tested manufacturing methods to produce innovative materials. All Griffolyn membranes are tested annually using current ASTM and other regulated testing methods to provide architects with the most accurate data for specifying vapor barriers.

Reef Industries will continue to produce high quality vapor barrier systems and provide architects with technical information and assistance in product selection and specification. Call 800/231-6074, extension 262C for answers to your questions about your critical applications.

Don't puncture the vapor retarder

Even small holes increase water-vapor emissions

BY BRUCE A. SUPRENANT AND WARD R. MALISCH

Specifiers often require concrete floors to be placed directly on a vapor retarder to reduce inflow of moisture from the subgrade soil and provide long-term protection for moisture-sensitive floor coverings. Water-vapor emissions as high as 100 pounds/1,000 square feet/24 hours have been measured over soils (Ref. 1).

Covering the subgrade with a vapor retarder can help reduce emission rates from concrete-floor surfaces to the 3 or 5 lbs/1,000 sf/24 hrs typically required by floor-covering installers. But what happens if the vapor retarder is punctured or installed incorrectly? (See "Sources of Vapor-Retarder Leaks.") To answer this question, The Aberdeen Group performed calcium-chloride cup tests on vapor retarders with and without holes.

Test setup and procedure

We performed the calcium-chloride cup tests over intact and punctured vapor retarders placed over a sand subbase at two moisture contents. We also varied vapor-retarder thickness and the size of the punctures.

Technicians placed ASTM C 33 concrete sand in twelve 16-inch-diameter, 3 $\frac{3}{4}$ -inch-deep metal pans. To simulate saturated sand, they poured water into eight of the pans until the water level was visible just below the top of the pan. They weighed the sand in the other four pans and added 8% water by weight to simulate a typical optimum moisture content for a granular subbase.

The technicians covered four of the saturated-sand samples with 8-mil-thick polyethylene sheeting and the other four with 40-mil-thick polyethylene, using duct tape to secure the overhanging sides to the pan and prevent moisture loss. They used a similar procedure to cover the four pans containing lower-moisture-content sand with an 8-mil-thick polyethylene sheet.

Figure 1 shows the test setup, and Table 1 shows the test condition of the vapor retarder. In each of the three sets of four pans, one vapor retarder was intact, one had

a $\frac{1}{8}$ -inch-diameter nail hole, one had a $\frac{1}{4}$ -inch-diameter stake hole and one had an opening cut to the size of the lid for the calcium-chloride test kit.

Technicians measured water-vapor emission rates for all 12 specimens, using calcium-chloride cup test kits that were left in place three days. After the first test, the filled pans were stored in the laboratory for

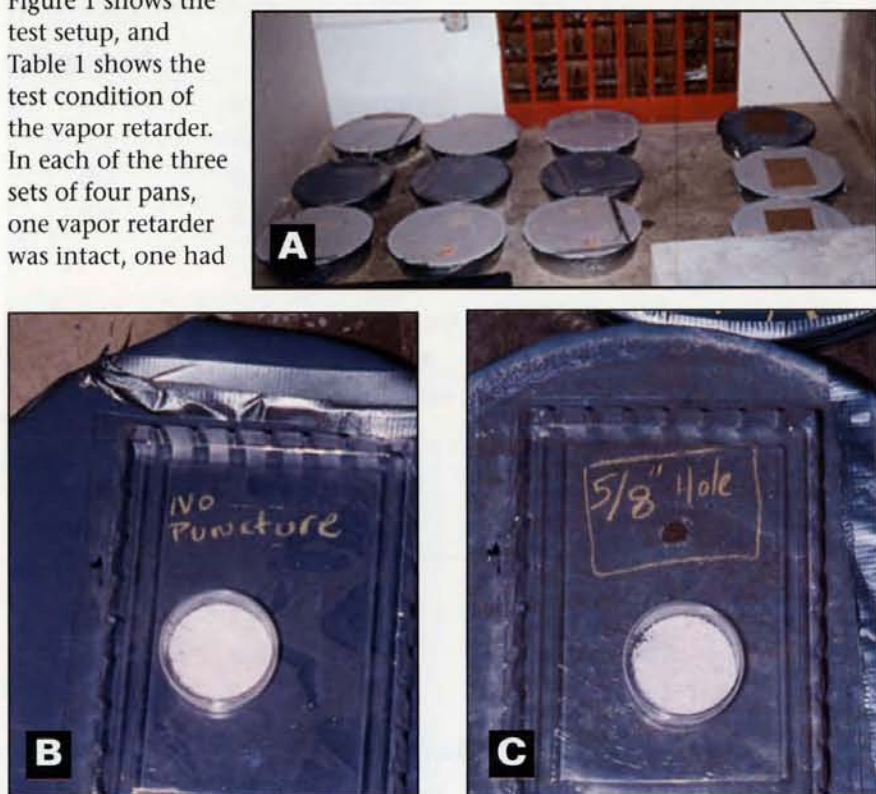

Figure 1. To measure water-vapor emissions through holes in the vapor retarder, eight pans filled with wet sand (photo A) were covered with 8-mil polyethylene sheeting (white) and four pans with 40-mil polyethylene (gray). Polyethylene covering three of the pans on the right had openings cut to the size of the lid for the vapor-emission test kit. As shown in photo B, emission rate from the uncovered sand was measured with the calcium-chloride cup placed directly on the sand. Photo C shows a test kit mounted over a $\frac{1}{8}$ -inch-diameter hole in the polyethylene covering.

about 10 weeks and then retested for vapor emissions. For the retest, no additional water was added to the sand.

Significant emissions through stake holes

Table 1 also shows the water-vapor emission rates for each initial test and retest. The emission rate through the vapor retarders with no holes averaged 0.6 lb/1,000 sf/24 hrs, and the results appear to indi-

cate a higher emission rate through the thicker vapor retarder. However, we have conducted many calcium-chloride cup tests, and our experience doesn't support a conclusion that reducing the vapor-retarder thickness reduces vapor-emission rate. We believe the measured differences in emission rates over the intact vapor retarders more likely reflect a high test-precision error relative to the low emission rates that were measured.

A 3/8-inch-diameter nail hole allowed an average emission rate of 1.3 lbs/1,000 sf/24 hrs, and a 3/4-inch-diameter stake hole increased the average emission rate to 3 lbs/1,000 sf/24 hrs. Stake holes of this size could conceivably cause localized floor-covering failures or delay floor-covering installation, since a 3-pound rate is often the maximum allowed for installation of moisture-sensitive floor coverings.

The measured water-vapor emission rate through the lid-sized opening was about the same regardless of the moisture content, and the rate didn't decrease after more than two months of drying. In the field this means that when concrete is placed on a granular layer that is above a vapor retarder, any trapped moisture—whether from rain, workers sprinkling the layer or compaction—will provide a significant amount of moisture to the concrete slab.

After the retests were completed, we measured the moisture content of the sand in the three pans with lid-sized openings in the polyethylene. The moisture contents of the saturated sand were 18.8% and 15.6% for the 8-mil and 40-mil polyethylene, respectively, while the moisture content of the 8% sand had dropped to 2.5%. Surprisingly, even the granular base with 2.5% moisture content emitted water vapor at about the same rate as the wetter subbases. However, the measured values were much lower than the maximum soil emission values cited in Reference 1.

Comparison with other vapor-retarder test results

Our results showing the effects of intact vapor retarders are similar to those from earlier tests by Brewer (Ref. 3). He measured moisture inflow from the subbase into 4-inch-thick concrete specimens with a water-cement ratio of 0.70 and placed directly on:

- Compacted clay
- Compacted clay covered with a gravel layer

Table 1 Moisture-emission test results (lbs/1,000 sf/24 hrs)

Initial test				
Date tested:	04/11/98	04/11/98	04/11/98	
Plastic thickness:	8 mil	40 mil	8 mil	
Sand moisture:	saturated	saturated	8% moisture	
Relative humidity:	32%	32%	32%	
Temperature:	70°F	70°F	70°F	
Test condition				Average
No holes	0.3	0.7	0.4	0.5
Nail hole — 3/8 in.	1.1	1.0	0.9	1.0
Stake hole — 3/4 in.	3.0	2.9	2.0	2.6
Open sand	8.9	9.4	8.8	9.0
Retest				
Date tested:	06/22/98	06/22/98	06/22/98	
Plastic thickness:	8 mil	40 mil	8 mil	
Sand moisture:	saturated	saturated	8% moisture	
Relative humidity:	50%	50%	50%	
Temperature:	72°F	72°F	72°F	
Test condition				Average
No holes	0.6	0.9	0.6	0.7
Nail hole — 3/8 in.	2.2	1.4	1.4	1.7
Stake hole — 3/4 in.	3.9	3.3	2.6	3.3
Open sand	11.4	12.5	11.4	11.7
Summary				
Test condition	Initial test	Retest	Average	
No holes	0.5	0.7	0.6	
Nail hole — 3/8 in.	1.0	1.7	1.3	
Stake hole — 3/4 in.	2.6	3.3	3.0	
Open sand	9.0	11.7	10.4	

- Compacted clay covered with a vapor retarder
 - Compacted clay covered with a gravel layer and vapor retarder
- He used two different vapor retarders: 4-mil polyethylene and 55-pound roofing felt. For details of his tests, see the article "Moisture Movement Through Concrete Slabs," *Concrete Construction*, November 1997, pp. 879-885.

Brewer started measuring moisture inflow about a month after the concrete had been placed. At this time, the inflow for concrete placed directly on compacted clay was about 20 lbs/1,000 sf/24 hrs. Inflow for the clay covered with a vapor retarder was about 7 lbs/1,000 sf/24 hrs.

Thus, an intact vapor retarder over a clay subgrade reduced moisture inflow by about 13 lbs/1,000 sf/24 hrs.

Inflow for concrete placed directly on a gravel layer over compacted clay was about 14 lbs/1,000 sf/24 hrs. Covering the clay and gravel with a vapor retarder had reduced inflow to about 6 lbs/1,000 sf/24 hrs. Thus, an intact vapor retarder over a gravel subbase reduced moisture inflow by about 8 lbs/1,000 sf/24 hrs, respectively.

Brewer's values are in the same range as our initial and retest values of about 9 and 11 lbs/1,000 sf/24 hrs, respectively, for intact vapor retarders placed over a wet sand sub-

base. Brewer wasn't able to detect vapor-emission differences between 4-mil polyethylene and 55-pound roofing felt, and we couldn't detect differences between 8-mil and 40-mil polyethylene.

Ensuring an effective vapor retarder

Because punctures or other openings in a vapor retarder can significantly increase water-vapor emissions through concrete floor slabs, specifiers should consider protective measures during the design process.

Some specifiers prefer a thick vapor retarder that will be more puncture-resistant during typical construction activities. Others require placement of a granular layer over the vapor retarder, specifying the use of a rounded gravel because angular crushed particles are more likely to puncture the vapor retarder. More cautious specifiers may require both a thicker vapor retarder and the placement of a rounded, granular layer over it. Whenever granular materials are placed over a vapor retarder, specifiers should be aware that a prolonged drying period may be needed if the granular materials get wet during building construction.

Contractors, too, must avoid damaging the vapor retarder. Some form manufacturers make supports for slab edge forms (Fig. 2) that don't require

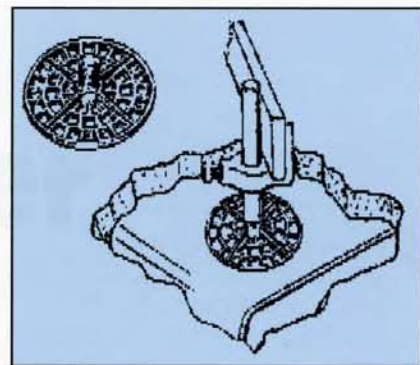

Figure 2. Pad-and-post supports for slab edge forms don't require puncturing the vapor retarder with a stake.

puncturing the vapor retarder with stakes. Many contractors use job-built edge-form supports with wide bearing pads to avoid puncturing the plastic with edge-form stakes.

Finally, contractors must install the vapor retarder correctly by following manufacturers' instructions that usually require:

- Lapping joints and sealing them
- Sealing around all penetrations
- Lapping over footings, sealing to foundation walls, or both
- Protecting the vapor retarder during installation of reinforcing steel and utilities and during concrete placement
- Repairing any damage to the vapor retarder

References

1. Heinz R. Trechsel, editor, *Moisture Control in Buildings*, ASTM Manual Series: MNL 18, ASTM, West Conshohocken, Pa., 1994.
2. ASTM E 1643, "Standard Practice for Installation of Water Vapor Retarders Used in Contact with Earth or Granular Fill Under Concrete Slabs," ASTM, 1994.
3. H.W. Brewer, "Moisture Migration—Concrete Slab-on-Ground Construction," *Journal of PCA Research and Development Laboratories*, Vol. 7, No. 2, Portland Cement Association, Skokie, Ill., May 1965.

Sources of vapor-retarder leaks

Through punctures caused by:

- Finishers poking holes in the vapor retarder so they can start work sooner. Because placing concrete directly on a vapor retarder instead of an absorptive base increases the bleeding period, some finishers do this to minimize delays.
- Workers puncturing the vapor retarder with stakes while placing edge forms and rebar supports.
- Vehicle traffic before and during the pour, which can rip the thin plastic sheets or cause underlying sharp aggregates to puncture them.

Through openings at:

- Unsealed edges along laps.
- Penetrations in the vapor retarder.
- Floor-wall joints. The vapor retarder should be pulled up at the sides and sealed to the footing or foundation wall, as recommended by Reference 2.

6 mil Polyethylene Vapor Retarder Failure

**Slab on Grade
Fulshear, Texas
Photographs - Summer 1998**







AVOID VAPOR RETARDER FAILURE WITH GRIFFOLYN REINFORCED VAPOR RETARDERS
CALL TODAY FOR SPECIFICATIONS AND YOUR PRICE QUOTE

Toll-Free 1-800-231-6074

9209 Almeda Genoa Rd. Houston, Texas 77075

Phone 713-507-4251 Fax 713-507-4295 E-mail - ri@reefindustries.com

www.reefindustries.com

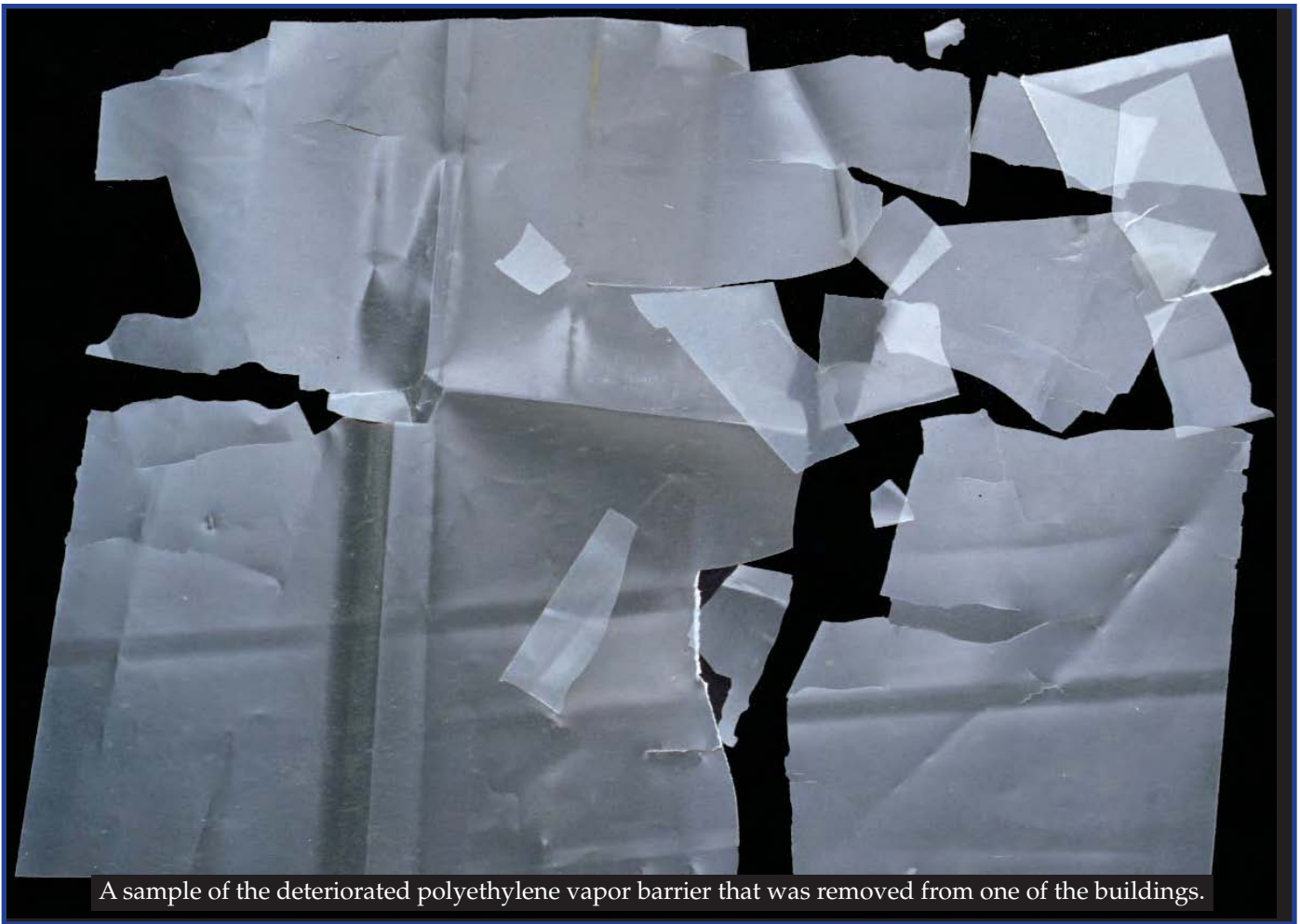

A sample of the deteriorated polyethylene vapor barrier that was removed from one of the buildings.

The following is a case study where 6 mil polyethylene was used as a vapor barrier and proved to be ineffective and very costly.

In 1990 two buildings were constructed in upstate New York. The preformed metal roofing system consisted of 22 ga. galvanized steel panels with 20 year paint finish, three inches of isocyanurate insulation, 6 mil polyethylene vapor barrier, and a galvanized steel structural deck. The building in question is a gymnasium building with no ceilings and is approximately 6 or 7 years old.

PROBLEM: After the building was approximately 1 1/2 to 2 years old, severe leakage developed. Water was dripping from holes in the structural deck where screws holding down girts had missed their mark and had been removed or had their threads or base metal stripped. The problem was attributed to the the vapor barrier. During the first and second winter the insulation was found to be completely saturated with water and frozen. Again this problem was attributed to moisture from within the building penetrating the faulty vapor

barrier. When the roof was removed, they found the polyethylene vapor barrier to be torn over most of the area. The leaking occurred only on sunny days during mid-winter until mid-spring. The first roof was removed and the vapor barrier was found not to be taped and in one case folded back on itself with no vapor protection. A new vapor barrier was installed properly and the problems ended in 1993-1994.

The second roof was partially checked in 1993 and only a small failure in installation was found and fixed. This area corresponded to 2/3 of the reported leaks. The following winter no leaks were reported. In the winter of 1994-1995 numerous leaks were reported, some in the same areas as before and a similar additional number in new areas.

In 1995-1996 the owner commissioned an emergency contract to replace the roof system. What was found was portions of the vapor barrier product

in total failure. It was cracked, broken and was discolored. It was so brittle it crumbled when touched.

SOLUTION: Install the Griffolyn® Vapor Barrier System and avoid the inconvenience and cost of untimely repairs. Made to last the life of the roof and resist thermally degrading, unlike the 6 mil polyethylene. The Griffolyn systems perform in the extreme temperatures required of a roofing system. No other product line on the market can match the unique set of benefits quality and performance.

Call today for technical assistance.

800/231-6074

GRIFFOLYN®
DIVISION OF REEF INDUSTRIES, INC.

9209 Almeda Genoa
Houston, Texas 77075
713/507-4251
713/507-4295 FAX
ri@reefindustries.com

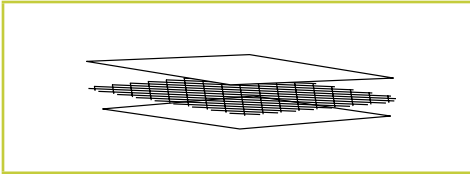

Griffolyn® Type-65 is a 3-ply laminate combining two layers of high-density polyethylene and a high-strength cord grid. The non-woven cord grid provides a uniform loading resistance. It is specifically engineered to provide high strength and durability in a lightweight material.

PHYSICAL PROPERTIES AND TYPICAL VALUES

PROPERTY	ASTM TEST METHOD	U.S. VALUE	METRIC VALUE
Weight	D-751	40 LB/1000 FT ²	19.5 KG/100 M ²
3" Tensile Strength	D-882	100 LBF	445 N
Puncture Strength	D-4833	24 LBF	106 N
PPT Resistance	D-2582	30 LBF	133 N
Dart Impact Strength	D-1709	1.1 LBS	500 g
Cold Impact Strength	D-1790	-40°F	-40°C
Permeance	E-96	0.038 Grain/Hr•Ft ² •in.Hg	2.18 NG/(PA•S•M ²)

FEATURES

- Multiple layers and cord reinforcement resist punctures and tears.
- UV stabilization protects the material from degradation during extended exposure to sunlight.
- Cold-crack resistance eliminates failures in extremely cold temperatures.
- Chemically resistant to withstand exposure without significant deterioration.
- Low permeability greatly inhibits moisture transmission.
- Flexibility and light weight allow for easy handling and quick installation.
- Custom fabrication is available to meet your exact specifications.
- High durability allows for significant savings through reuse and fewer replacements.
- Class C, ASTM E-1745-97 Standard Specification for Water Vapor Retarders Used in Contact With Soil or Granular Fill Under Concrete Slabs.

The information provided herein is based upon data believed to be reliable. All testing is performed in accordance with ASTM standards and procedures. All values are typical and nominal and do not represent either minimum or maximum performance of the product. Although the information is accurate to the best of our knowledge and belief, no representation of warranty or guarantee is made as to the suitability or completeness of such information. Likewise, no representation of warranty or guarantee, expressed or implied, or merchantability, fitness or otherwise, is made as to product application for a particular use.

©2006 REEF INDUSTRIES, INC. Griffolyn is a registered trademark of Reef Industries, Inc. 09-06

TOLLFREE 1.800.231.6074

9209 Alameda Genoa Rd. • Houston, Texas 77075
 P: 713.507.4251 • F: 713.507.4295
 Email: ri@reefindustries.com



SUGGESTED APPLICATIONS

- Architectural vapor retarder for underslab, in walls & ceilings and in roofing systems.
- Pallet, cable reel and drum covers for outside storage.
- Floor covers, dust partitions and cleanroom enclosures.
- Temporary walls, plant dividers, building enclosures and containment tents.
- Shipping container covers and liners.
- Soil covers to control leachate for stockpiles and landfills.
- Erosion control and slope protection covers.

ORDERING INFORMATION

AVAILABLE COLORS:

Black

SIZES:

Standard rolls from 4' x 100' to 40' x 100' in increments of 4' widths are available for immediate shipment. Standard length and width tolerances are $\pm 1\%$ (minimum 2")

Custom sizes up to 120' x 200' and custom fabrication are available to meet your exact specifications.

USABLE TEMPERATURE RANGE:

Minimum: -25°F -31.6°C

Maximum: 170°F 77°C

OUTDOOR EXPOSURE

Under normal continuous exposure the average life expectancy ranges from 18 to 30 months, depending on color.

The information provided herein is based upon data believed to be reliable. All testing is performed in accordance with ASTM standards and procedures. All values are typical and nominal and do not represent either minimum or maximum performance of the product. Although the information is accurate to the best of our knowledge and belief, no representation of warranty or guarantee is made as to the suitability or completeness of such information. Likewise, no representation of warranty or guarantee, expressed or implied, or merchantability, fitness or otherwise, is made as to product application for a particular use.

©2006 REEF INDUSTRIES, INC. Griffolyn is a registered trademark of Reef Industries, Inc. 09-06

TOLLFREE 1.800.231.6074

9209 Almeda Genoa Rd. • Houston, Texas 77075

P: 713.507.4251 • F: 713.507.4295

Email: ri@reefindustries.com



GRIFFOLYN® TYPE-85

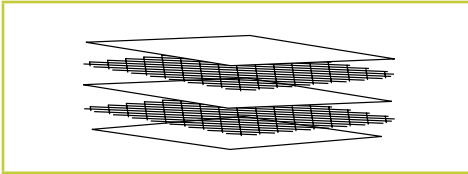

Griffolyn® Type-85 is a 5-ply laminate combining three layers of high density polyethylene and two high-strength cord grids. It is specifically engineered to provide high strength and durability in a lightweight material.

PHYSICAL PROPERTIES AND TYPICAL VALUES

PROPERTY	ASTM TEST METHOD	U.S. VALUE	METRIC VALUE
Weight	D-3776	70 LB/1000 FT ²	34.2 KG/100 M ²
3" Tensile Strength	D-882	225 LBF	1000 N
Puncture Strength	D-4833	50 LBF	222 N
PPT Resistance	D-2582	60 LBF	267 N
Dart Impact Strength	D-1709	4 LBS	1800 g
Cold Impact Strength	D-1790	-40°F	-40°C
Permeance	E-96	0.027 Grain/Hr•Ft ² •in.Hg	1.551 NG/(PA•S•M ²)

FEATURES

- Multiple layers and cord reinforcement resist punctures and tears.
- UV stabilization protects the material from degradation during extended exposure to sunlight.
- Cold-crack resistance eliminates failures in extremely cold temperatures.
- Chemically resistant to withstand exposure without significant deterioration.
- Low permeability greatly inhibits moisture transmission.
- Flexibility and light weight allow for easy handling and quick installation.
- Custom fabrication is available to meet your exact specifications.
- High durability allows for significant savings through reuse and fewer replacements.
- Class B, ASTM E-1745-97 Standard Specification for Water Vapor Retarders Used in Contact With Soil or Granular Fill Under Concrete Slabs.

The information provided herein is based upon data believed to be reliable. All testing is performed in accordance with ASTM standards and procedures. All values are typical and nominal and do not represent either minimum or maximum performance of the product. Although the information is accurate to the best of our knowledge and belief, no representation of warranty or guarantee is made as to the suitability or completeness of such information. Likewise, no representation of warranty or guarantee, expressed or implied, or merchantability, fitness or otherwise, is made as to product application for a particular use.

©2006 REEF INDUSTRIES, INC. Griffolyn is a registered trademark of Reef Industries, Inc. 09-06

TOLLFREE 1.800.231.6074

9209 Alameda Genoa Rd. • Houston, Texas 77075

P: 713.507.4251 • F: 713.507.4295

Email: ri@reefindustries.com

REEF INDUSTRIES, INC.
The Manufacturing Leader of Specialized Industrial Plastic Films Since 1957.

TYPE-85

GRIFFOLYN®

PRODUCT INFORMATION • SPECIFICATION GUIDE



SUGGESTED APPLICATIONS

- Pallet, cable reel and drum covers for outside storage.
- Floor covers, dust partitions and cleanroom enclosures.
- Temporary walls, plant dividers, building enclosures and containment tents.
- Architectural vapor retarder for underslab, walls & ceilings and in roofing systems.
- Shipping container covers and liners.
- Soil covers to control leachate for stockpiles and landfills.
- Erosion control and slope protection covers.
- Agricultural storage systems, hay covers and windbreaks.
- Athletic field and equipment covers.

ORDERING INFORMATION

AVAILABLE COLORS:

Black

SIZES:

Standard rolls from 4' x 100' to 40' x 100' in increments of 4' widths are available for immediate shipment. Standard length and width tolerances are $\pm 1\%$ (minimum 2")

Custom sizes up to 150' x 200' and custom fabrication are available to meet your exact specifications.

USABLE TEMPERATURE RANGE:

Minimum: -40°F -40°C

Maximum: 170°F 77°C

OUTDOOR EXPOSURE

Under normal continuous exposure the average life expectancy ranges from 36 to 48 months.

The information provided herein is based upon data believed to be reliable. All testing is performed in accordance with ASTM standards and procedures. All values are typical and nominal and do not represent either minimum or maximum performance of the product. Although the information is accurate to the best of our knowledge and belief, no representation of warranty or guarantee is made as to the suitability or completeness of such information. Likewise, no representation of warranty or guarantee, expressed or implied, or merchantability, fitness or otherwise, is made as to product application for a particular use.

©2006 REEF INDUSTRIES, INC. Griffolyn is a registered trademark of Reef Industries, Inc. 09-06

TOLLFREE 1.800.231.6074

9209 Almeda Genoa Rd. • Houston, Texas 77075

P: 713.507.4251 • F: 713.507.4295

Email: ri@reefindustries.com



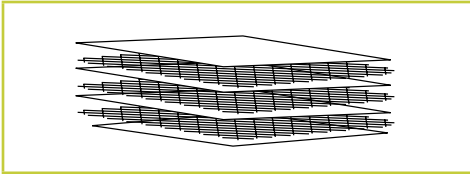

Griffolyn® Type-105 is a 7-ply laminate combining four layers of high density polyethylene and three high-strength cord grids. It is specifically engineered to provide high strength and durability in a lightweight material.

PHYSICAL PROPERTIES AND TYPICAL VALUES

PROPERTY	ASTM TEST METHOD	U.S. VALUE	METRIC VALUE
Weight	D-3776	86 LB/1000 FT ²	42 KG/100 M ²
3" Tensile Strength	D-882	275 LBF	1223 N
Puncture Strength	D-4833	72 LBF	320 N
PPT Resistance	D-2582	50 LBF	222 N
Dart Impact Strength	D-1709	5.0 LBS	2300 g
Cold Impact Strength	D-1790	-40°F	-40°C
Permeance	E-96	0.021 Grain/Hr•Ft ² •in.Hg	1.207 NG/(PA•S•M ²)

FEATURES

- Multiple layers and cord reinforcement resist punctures and tears.
- UV stabilization protects the material from degradation during extended exposure to sunlight.
- Cold-crack resistance eliminates failures in extremely cold temperatures.
- Chemically resistant to withstand exposure without significant deterioration.
- Low permeability greatly inhibits moisture transmission.
- Flexibility and light weight allow for easy handling and quick installation.
- Custom fabrication is available to meet your exact specifications.
- High durability allows for significant savings through reuse and fewer replacements.
- Class A, ASTM E-1745-97 Standard Specification for Water Vapor Retarders Used in Contact With Soil or Granular Fill Under Concrete Slabs.

The information provided herein is based upon data believed to be reliable. All testing is performed in accordance with ASTM standards and procedures. All values are typical and nominal and do not represent either minimum or maximum performance of the product. Although the information is accurate to the best of our knowledge and belief, no representation of warranty or guarantee is made as to the suitability or completeness of such information. Likewise, no representation of warranty or guarantee, expressed or implied, or merchantability, fitness or otherwise, is made as to product application for a particular use.

TOLLFREE 1.800.231.6074

9209 Alameda Genoa Rd. • Houston, Texas 77075
 P: 713.507.4251 • F: 713.507.4295
 Email: ri@reefindustries.com



SUGGESTED APPLICATIONS

- Pallet, cable reel and drum covers for outside storage.
- Floor covers, dust partitions and cleanroom enclosures.
- Temporary walls, plant dividers, building enclosures and containment tents.
- Architectural vapor retarder for underslab, walls & ceilings and in roofing systems.
- Shipping container covers and liners.
- Soil covers to control leachate for stockpiles and landfills.
- Erosion control and slope protection covers.
- Agricultural storage systems, hay covers and windbreaks.
- Athletic field and equipment covers.

ORDERING INFORMATION

AVAILABLE COLORS:

Black

SIZES:

Standard rolls from 4' x 100' to 40' x 100' in increments of 4' widths are available for immediate shipment. Standard length and width tolerances are $\pm 1\%$ (minimum 2")

Custom sizes up to 100' x 200' and custom fabrication are available to meet your exact specifications.

USABLE TEMPERATURE RANGE:

Minimum: -45°F -42°C

Maximum: 170°F 77°C

OUTDOOR EXPOSURE

Under normal continuous exposure the average life expectancy ranges from 30 to 48 months.

The information provided herein is based upon data believed to be reliable. All testing is performed in accordance with ASTM standards and procedures. All values are typical and nominal and do not represent either minimum or maximum performance of the product. Although the information is accurate to the best of our knowledge and belief, no representation of warranty or guarantee is made as to the suitability or completeness of such information. Likewise, no representation of warranty or guarantee, expressed or implied, or merchantability, fitness or otherwise, is made as to product application for a particular use.

©2006 REEF INDUSTRIES, INC. Griffolyn is a registered trademark of Reef Industries, Inc. 09-06

TOLLFREE 1.800.231.6074

9209 Almeda Genoa Rd. • Houston, Texas 77075

P: 713.507.4251 • F: 713.507.4295

Email: ri@reefindustries.com



GRIFFOLYN® TYPE-65 G

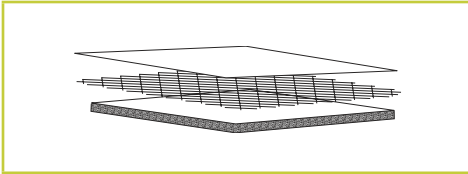

Griffolyn® Type-65 G is a 3-ply laminate combining two layers of high density polyethylene and a high-strength cord grid with a layer of non-woven geotextile fiber. It is specifically engineered to provide high strength and durability in a lightweight material.

PHYSICAL PROPERTIES AND TYPICAL VALUES

PROPERTY	ASTM TEST METHOD	U.S. VALUE	METRIC VALUE
Weight	D-3776	76 LB/1000 FT ²	37.1 KG/100 M ²
3" Tensile Strength	D-882	190 LBF	845 N
Puncture Strength	D-4833	102 LBF	450 N
PPT Resistance	D-2582	56 LBF	249 N
Dart Impact Strength	D-1709	4.85 LBS	2200 g
Cold Impact Strength	D-1790	-40°F	-40°C
Permeance	E-96	0.038 Grain/Hr•Ft ² •in.Hg	2.125 NG/(PA•S•M ²)

FEATURES

- Multiple layers and cord reinforcement combined with the geotextile layer offer extremely high puncture and tear resistance.
- UV stabilization protects the material from degradation during extended exposure to sunlight.
- Cold-crack resistance eliminates failures in extremely cold temperatures.
- Low permeability greatly inhibits moisture transmission.
- Flexibility and light weight allow for easy handling and quick installation.
- Custom fabrication is available to meet your exact specifications.
- Class A, ASTM E-1745-97 Standard Specification for Water Vapor Retarders Used in Contact With Soil or Granular Fill Under Concrete Slabs.

SUGGESTED APPLICATIONS

Architectural vapor retarder under slab on grade.

The information provided herein is based upon data believed to be reliable. All testing is performed in accordance with ASTM standards and procedures. All values are typical and nominal and do not represent either minimum or maximum performance of the product. Although the information is accurate to the best of our knowledge and belief, no representation of warranty or guarantee is made as to the suitability or completeness of such information. Likewise, no representation of warranty or guarantee, expressed or implied, or merchantability, fitness or otherwise, is made as to product application for a particular use.

©2006 REEF INDUSTRIES, INC. Griffolyn is a registered trademark of Reef Industries, Inc. 09-06

TOLLFREE 1.800.231.6074

9209 Alameda Genoa Rd. • Houston, Texas 77075

P: 713.507.4251 • F: 713.507.4295

Email: ri@reefindustries.com

REEF INDUSTRIES, INC.

The Manufacturing Leader of Specialized Industrial Plastic Films Since 1957.

TYPE-65 G

GRIFFOLYN®

PRODUCT INFORMATION • SPECIFICATION GUIDE



ORDERING INFORMATION

AVAILABLE COLORS:

Black

SIZES:

Standard rolls from 4' x 100' to 40' x 100' in increments of 4' widths are available for immediate shipment. Standard length and width tolerances are $\pm 1\%$ (minimum 2")

Custom sizes up to 100' x 100' and custom fabrication are available to meet your exact specifications.

USABLE TEMPERATURE RANGE:

Minimum: -25°F -31.6°C

Maximum: 170°F 77°C

OUTDOOR EXPOSURE

Under normal continuous exposure the average life expectancy ranges from 18 to 30 months, depending on color.

The information provided herein is based upon data believed to be reliable. All testing is performed in accordance with ASTM standards and procedures. All values are typical and nominal and do not represent either minimum or maximum performance of the product. Although the information is accurate to the best of our knowledge and belief, no representation of warranty or guarantee is made as to the suitability or completeness of such information. Likewise, no representation of warranty or guarantee, expressed or implied, or merchantability, fitness or otherwise, is made as to product application for a particular use.

©2006 REEF INDUSTRIES, INC. Griffolyn is a registered trademark of Reef Industries, Inc. 09-06

TOLLFREE 1.800.231.6074

9209 Alameda Genoa Rd. • Houston, Texas 77075

P: 713.507.4251 • F: 713.507.4295

Email: ri@reefindustries.com



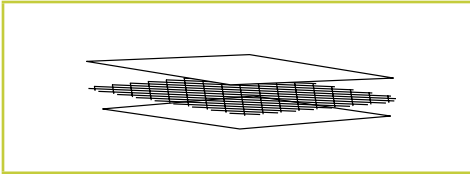

Griffolyn® Type-55 FR is a 3-ply laminate combining two layers of fire retardant low density polyethylene and a high-strength cord grid. It is specifically engineered to provide high strength and durability in a lightweight material.

PHYSICAL PROPERTIES AND TYPICAL VALUES	PROPERTY	ASTM TEST METHOD	U.S. VALUE	METRIC VALUE
	Weight	D-3776	30 LB/1000 FT ²	14.6 KG/100 M ²
	3" Tensile Strength	D-882	80 LBF	356 N
	3" Load @ Break	D-882	26 LBF	116 N
			1590 PSI	10.7 MPA
	Tongue Tear	D-751 B	11 LBF	49 N
	Trapezoidal Tear	D-4533	24 LBF	107 N
	PPT Resistance	D-2582	21 LBS	93 N
	Dart Impact Strength	D-1709	1.1 LBS	.5 KG
	Cold Impact Strength	D-1790	-20°F	-28°C
Permeance	E-96	0.062 Grain/Hr•Ft ² •in.Hg	3.556 NG/(PA•S•M ²)	
Fire Retardancy	E-84	5 flame spread, 60 smoke developed		
	NFPA 701	Pass		

Conforms to the following safety codes:

- Passes NFPA 701 Large Scale – “Standard Methods of Fire Tests for Flame-Resistant Textiles and Films”.
- Class I, Class A flame spread rating per UBC-42 and ASTM E-84.

FEATURES

- Fire retardant to meet safety requirements in critical equipment and material areas.
- Multiple layers and cord reinforcement resist punctures and tears.
- Cold-crack resistance eliminates failures in extremely cold temperatures.
- Low permeability greatly inhibits moisture transmission.
- Flexibility and light weight allow for easy handling and quick installation.
- Custom fabrication is available to meet your exact specifications.
- High durability allows for significant savings through reuse and fewer replacements.

The information provided herein is based upon data believed to be reliable. All testing is performed in accordance with ASTM standards and procedures. All values are typical and nominal and do not represent either minimum or maximum performance of the product. Although the information is accurate to the best of our knowledge and belief, no representation of warranty or guarantee is made as to the suitability or completeness of such information. Likewise, no representation of warranty or guarantee, expressed or implied, or merchantability, fitness or otherwise, is made as to product application for a particular use.

TOLLFREE 1.800.231.6074

9209 Alameda Genoa Rd. • Houston, Texas 77075
 P: 713.507.4251 • F: 713.507.4295
 Email: ri@reefindustries.com



SUGGESTED APPLICATIONS

- Temporary walls, plant dividers, building enclosures and containment tents.
- Shipping container covers and liners.
- Floor covers, dust partitions and cleanroom enclosures.
- Bags and tubing (printing available).
- Industrial Packaging.
- Custom covers and outside storage.
- Architectural vapor retarder in walls, ceilings and in roofing systems.

ORDERING INFORMATION

AVAILABLE COLORS:

Natural, Blue, Yellow and Green

SIZES:

Standard rolls from 4' x 100' to 40' x 100' in increments of 4' widths are available for immediate shipment. Standard length and width tolerances are $\pm 1\%$ (minimum 2")

Custom sizes up to 100' x 125' and custom fabrication are available to meet your exact specifications.

USABLE TEMPERATURE RANGE:

Minimum: -5°F -20°C

Maximum: 150°F 66°C

OUTDOOR EXPOSURE

Under normal continuous exposure the average life expectancy ranges from 10 to 12 months, depending on color.

The information provided herein is based upon data believed to be reliable. All testing is performed in accordance with ASTM standards and procedures. All values are typical and nominal and do not represent either minimum or maximum performance of the product. Although the information is accurate to the best of our knowledge and belief, no representation of warranty or guarantee is made as to the suitability or completeness of such information. Likewise, no representation of warranty or guarantee, expressed or implied, or merchantability, fitness or otherwise, is made as to product application for a particular use.

©2006 REEF INDUSTRIES, INC. Griffolyn is a registered trademark of Reef Industries, Inc. 09-06

TOLLFREE 1.800.231.6074

9209 Almeda Genoa Rd. • Houston, Texas 77075

P: 713.507.4251 • F: 713.507.4295

Email: ri@reefindustries.com



GRIFFOLYN® T-55 ASFR

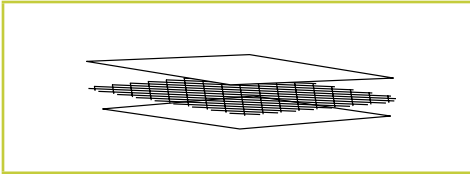

Griffolyn® Type-55 ASFR is a 3-ply laminate combining two layers of antistatic fire retardant, low density polyethylene film and a high-strength cord grid. It is specifically engineered to provide high strength and durability in a lightweight material.

PHYSICAL PROPERTIES AND TYPICAL VALUES	PROPERTY	ASTM TEST METHOD	U.S. VALUE	METRIC VALUE
	Weight	D-2103	34.3 LB/1000 FT ²	16.7 KG/100 M ²
	3" Tensile Strength	D-882	82 LBF	364 N
	3" Load @ Break	D-882	20 LBF	89 N
			1100 PSI	8 MPA
	3" Elongation @ Break	D-882	190 %	190 %
	Tongue Tear	D-751 B	12 LBF	53 N
	PPT Resistance	D-2582	19 LBF	85 N
	Dart Impact Strength	D-1709	1.0 LBF	0.45 KG
	Cold Impact Strength	D-1790	-0°F	-18°C
	Static Decay (50% RH, 10% cutoff)	NFPA-99	0.02 seconds	0.02 seconds
	Surface Resistivity	NFPA-99	4.8 x 10 ¹⁰ Ohms	4.8 x 10 ¹⁰ Ohms
Fire Retardancy	E-84	15 flame spread, 60 smoke developed		
	NFPA 701	Pass		

Conforms to the following safety codes:

- Passes NFPA 701 Large Scale – “Standard Methods of Fire Tests for Flame-Resistant Textiles and Films”.
- Class I, Class A flame spread rating per UBC-42 and ASTM E-84.

FEATURES

- Fire retardant to meet safety requirements in critical equipment and material areas.
- Multiple layers and cord reinforcement resist punctures and tears.
- Cold-crack resistance eliminates failures in cold temperatures.
- Low permeability greatly inhibits moisture transmission.
- Flexibility and light weight allow for easy handling and quick installation.
- Custom fabrication is available to meet your exact specifications.
- High durability allows for significant savings through reuse and fewer replacements.

The information provided herein is based upon data believed to be reliable. All testing is performed in accordance with ASTM standards and procedures. All values are typical and nominal and do not represent either minimum or maximum performance of the product. Although the information is accurate to the best of our knowledge and belief, no representation of warranty or guarantee is made as to the suitability or completeness of such information. Likewise, no representation of warranty or guarantee, expressed or implied, or merchantability, fitness or otherwise, is made as to product application for a particular use.

TOLLFREE 1.800.231.6074

9209 Alameda Genoa Rd. • Houston, Texas 77075
 P: 713.507.4251 • F: 713.507.4295
 Email: ri@reefindustries.com



SUGGESTED APPLICATIONS

- Temporary walls, plant dividers, building enclosures and containment tents.
- Shipping container covers and liners.
- Floor covers, dust partitions and cleanroom enclosures.
- Bags and tubing (printing available).
- Industrial Packaging.

ORDERING INFORMATION

AVAILABLE COLORS:

Natural

SIZES:

Standard rolls from 4' x 100' to 40' x 100' in increments of 4' widths are available for immediate shipment. Standard length and width tolerances are $\pm 1\%$ (minimum 2")

Custom sizes up to 100' x 200' and custom fabrication are available to meet your exact specifications.

USABLE TEMPERATURE RANGE:

Minimum: 0°F -18°C

Maximum: 170°F 77°C

OUTDOOR EXPOSURE

Under normal continuous exposure the average life expectancy ranges from 8 to 12 months, depending on color.

The information provided herein is based upon data believed to be reliable. All testing is performed in accordance with ASTM standards and procedures. All values are typical and nominal and do not represent either minimum or maximum performance of the product. Although the information is accurate to the best of our knowledge and belief, no representation of warranty or guarantee is made as to the suitability or completeness of such information. Likewise, no representation of warranty or guarantee, expressed or implied, or merchantability, fitness or otherwise, is made as to product application for a particular use.

©2006 REEF INDUSTRIES, INC. Griffolyn is a registered trademark of Reef Industries, Inc. 09-06

TOLLFREE 1.800.231.6074

9209 Alameda Genoa Rd. • Houston, Texas 77075

P: 713.507.4251 • F: 713.507.4295

Email: ri@reefindustries.com



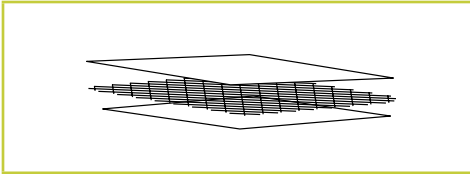

Griffolyn® TX-1200 FR is a 3-ply laminate combining two layers of fire retardant, linear, low density polyethylene and a high-strength cord grid. It is specifically engineered to provide high strength and durability in a lightweight material.

PHYSICAL PROPERTIES AND TYPICAL VALUES

PROPERTY	ASTM TEST METHOD	U.S. VALUE	METRIC VALUE
Weight	D-3776	41 LB/1000 FT ²	19.9 KG/100 M ²
3" Tensile Strength	D-882	90 LBF	400 N
Puncture Strength	D-4833	36 LBF	160 N
PPT Resistance	D-2582	25 LBF	111 N
Dart Impact Strength	D-1709	1.05 LBS	480 g
Cold Impact Strength	D-1790	-15°F	-27°C
Permeance	E-96	0.035 Grain/Hr•Ft ² •in.Hg	2.011 NG/(PA•S•M ²)
Fire Retardancy	E-84	5 flame spread, 70 smoke developed	
	NFPA 701	Pass	

Conforms to the following safety codes:

- Passes NFPA 701 Large Scale – “Standard Methods of Fire Tests for Flame-Resistant Textiles and Films”.
- Class I, Class A flame spread rating per UBC-42 and ASTM E-84.

FEATURES

- Multiple layers and cord reinforcement resist punctures and tears.
- Cold-crack resistance eliminates failures in cold temperatures.
- Low permeability greatly inhibits moisture transmission.
- Flexibility and light weight allow for easy handling and quick installation.
- Custom fabrication is available to meet your exact specifications.
- Long life expectancy allows for significant cost savings through reuse and fewer replacements.

SUGGESTED APPLICATIONS

- Temporary walls, plant dividers, building enclosures and containment tents.
- Floor covers, dust partitions and cleanroom enclosures.
- Architectural vapor retarder in walls & ceilings and in roofing systems.
- Pallet, cask and drum covers for outside storage.
- Shipping container covers and liners.

The information provided herein is based upon data believed to be reliable. All testing is performed in accordance with ASTM standards and procedures. All values are typical and nominal and do not represent either minimum or maximum performance of the product. Although the information is accurate to the best of our knowledge and belief, no representation of warranty or guarantee is made as to the suitability or completeness of such information. Likewise, no representation of warranty or guarantee, expressed or implied, or merchantability, fitness or otherwise, is made as to product application for a particular use.

TOLLFREE 1.800.231.6074

9209 Alameda Genoa Rd. • Houston, Texas 77075
 P: 713.507.4251 • F: 713.507.4295
 Email: ri@reefindustries.com



ORDERING INFORMATION

AVAILABLE COLORS:

Natural and Yellow

SIZES:

Standard rolls from 4' x 100' to 40' x 100' in increments of 4' widths are available for immediate shipment. Standard length and width tolerances are $\pm 1\%$ (minimum 2")

Custom sizes up to 100' x 200' and custom fabrication are available to meet your exact specifications.

USABLE TEMPERATURE RANGE:

Minimum: -15°F -27°C

Maximum: 170°F 77°C

OUTDOOR EXPOSURE

Under normal continuous exposure the average life expectancy ranges from 10 to 12 months, depending on color.

The information provided herein is based upon data believed to be reliable. All testing is performed in accordance with ASTM standards and procedures. All values are typical and nominal and do not represent either minimum or maximum performance of the product. Although the information is accurate to the best of our knowledge and belief, no representation of warranty or guarantee is made as to the suitability or completeness of such information. Likewise, no representation of warranty or guarantee, expressed or implied, or merchantability, fitness or otherwise, is made as to product application for a particular use.

©2006 REEF INDUSTRIES, INC. Griffolyn is a registered trademark of Reef Industries, Inc. 09-06

TOLLFREE 1.800.231.6074

9209 Alameda Genoa Rd. • Houston, Texas 77075

P: 713.507.4251 • F: 713.507.4295

Email: ri@reefindustries.com



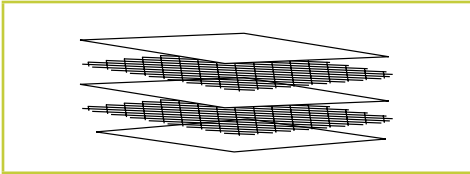

Griffolyn® Type-90 FR is a 5-ply laminate combining three layers of fire retardant, linear low density polyethylene and two high-strength cord grids. It is specifically engineered to provide high strength and durability in a lightweight material.

PHYSICAL PROPERTIES AND TYPICAL VALUES	PROPERTY	ASTM TEST METHOD	U.S. VALUE	METRIC VALUE
	Weight	D-3776	64 LB/1000 FT ²	31.5 KG/100 M ²
	3" Tensile Strength	D-882	165 LBF	734 N
	3" Load @ Break	D-882	68 LBF	302 N
			1550 PSI	10.7 MPA
	3" Elongation @ Break	D-882	350 %	350 %
	Tongue Tear	D-882	24 LBF	107 N
	Trapezoidal Tear	D-4533	40 LBF	178 N
	Puncture Strength	D-4833	47 LBF	209 N
	PPT Resistance	D-2582	42 LBF	187 N
	Dart Impact Strength	D-1709	2 LBS	.9 KG
	Cold Impact Strength	D-1790	-40°F	-40°C
	Permeance	E-96	0.028 Grain/Hr•Ft ² •in.Hg	1.606 NG/(PA•S•M ²)
Fire Retardancy	E-84	5 flame spread, 135 smoke developed		
	NFPA 701	Pass		

Conforms to the following safety codes:

- Passes NFPA 701 Large Scale – “Standard Methods of Fire Tests for Flame-Resistant Textiles and Films”.

FEATURES

- Multiple layers and cord reinforcement resist punctures and tears.
- Flexibility and light weight allow for easy handling and quick installation.
- Custom fabrication is available to meet your exact specifications.
- Long life expectancy allows for significant cost savings through reuse and fewer replacements.

The information provided herein is based upon data believed to be reliable. All testing is performed in accordance with ASTM standards and procedures. All values are typical and nominal and do not represent either minimum or maximum performance of the product. Although the information is accurate to the best of our knowledge and belief, no representation of warranty or guarantee is made as to the suitability or completeness of such information. Likewise, no representation of warranty or guarantee, expressed or implied, or merchantability, fitness or otherwise, is made as to product application for a particular use.

TOLLFREE 1.800.231.6074

9209 Alameda Genoa Rd. • Houston, Texas 77075
 P: 713.507.4251 • F: 713.507.4295
 Email: ri@reefindustries.com



SUGGESTED APPLICATIONS

- Temporary walls, plant dividers, building enclosures and containment tents.
- Architectural vapor retarders in walls, ceilings and roofing systems.
- Floor covers, dust partitions and cleanroom enclosures.
- Equipment covers.
- Pallet and custom covers for outside storage.
- Custom shipping container covers and liners.
- Environmental covers for waste containment and disposal.

ORDERING INFORMATION

AVAILABLE COLORS:

Green

SIZES:

Standard rolls from 4' x 100' to 40' x 100' in increments of 4' widths are available for immediate shipment. Standard length and width tolerances are $\pm 1\%$ (minimum 2")

Custom sizes up to 100' x 150' and custom fabrication are available to meet your exact specifications.

USABLE TEMPERATURE RANGE:

Minimum: -50°F -45°C

Maximum: 170°F 77°C

OUTDOOR EXPOSURE

Under normal continuous exposure the average life expectancy ranges from 10 to 12 months.

The information provided herein is based upon data believed to be reliable. All testing is performed in accordance with ASTM standards and procedures. All values are typical and nominal and do not represent either minimum or maximum performance of the product. Although the information is accurate to the best of our knowledge and belief, no representation of warranty or guarantee is made as to the suitability or completeness of such information. Likewise, no representation of warranty or guarantee, expressed or implied, or merchantability, fitness or otherwise, is made as to product application for a particular use.

©2006 REEF INDUSTRIES, INC. Griffolyn is a registered trademark of Reef Industries, Inc. 09-06

TOLLFREE 1.800.231.6074

9209 Alameda Genoa Rd. • Houston, Texas 77075

P: 713.507.4251 • F: 713.507.4295

Email: ri@reefindustries.com



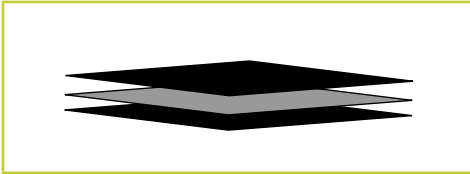

Vaporguard® is a 3-ply laminate with an aluminum core surrounded by two layers of multi-axially oriented, high density polyethylene. It is specifically engineered to provide high strength and durability in a lightweight material.

PHYSICAL PROPERTIES AND TYPICAL VALUES

PROPERTY	ASTM TEST METHOD	U.S. VALUE	METRIC VALUE
Weight	D-3776	72 LB/1000 FT ²	35 KG/100 M ²
3" Tensile Strength	D-882	110 LBF	489 N
Puncture Strength	D-4833	50 LBF	222 N
PPT Resistance	D-2582	18 LBF	80 N
Dart Impact Strength	D-1709	4.0 LBS	1800 g
Cold Impact Strength	D-1790	-50°F	-45°C
Permeance	E-96	0.000 Grain/Hr•Ft ² •in.Hg	0.0 NG/(PA•S•M ²)

FEATURES

- Multiple polyethylene layers and aluminum layer provide extremely low permeability and resist punctures and tears.
- UV stabilization protects the material from degradation during extended exposure to sunlight.
- Cold-crack resistance eliminates failures in extremely cold temperatures.
- Chemically resistant to withstand exposure without significant deterioration.
- Aluminum core provides extremely low permeability for minimal moisture transmission.
- Flexibility and light weight allow for easy handling and quick installation.
- Custom fabrication is available to meet your exact specifications.
- Class B, ASTM E-1745-97 Standard Specification for Water Vapor Retarders Used in Contact With Soil or Granular Fill Under Concrete Slabs.

The information provided herein is based upon data believed to be reliable. All testing is performed in accordance with ASTM standards and procedures. All values are typical and nominal and do not represent either minimum or maximum performance of the product. Although the information is accurate to the best of our knowledge and belief, no representation of warranty or guarantee is made as to the suitability or completeness of such information. Likewise, no representation of warranty or guarantee, expressed or implied, or merchantability, fitness or otherwise, is made as to product application for a particular use.

TOLLFREE 1.800.231.6074

9209 Alameda Genoa Rd. • Houston, Texas 77075
 P: 713.507.4251 • F: 713.507.4295
 Email: ri@reefindustries.com



SUGGESTED APPLICATIONS

- Architectural vapor retarder for underslab, walls & ceilings and in roofing systems. Ideal for cold storage and high moisture areas.
- Floor covers, dust partitions and cleanroom enclosures.
- Temporary walls, plant dividers, building enclosures and containment tents.
- Soil covers to control leachate for stockpiles and landfills.
- Erosion control and slope protection covers.

ORDERING INFORMATION

AVAILABLE COLORS:

Black

SIZES:

Standard rolls from 4' x 100' to 40' x 100' in increments of 4' widths are available for immediate shipment. Standard length and width tolerances are $\pm 1\%$ (minimum 2")

Custom sizes up to 100' x 120' and custom fabrication are available to meet your exact specifications.

USABLE TEMPERATURE RANGE:

Minimum: -50°F -45°C

Maximum: 170°F 77°C

OUTDOOR EXPOSURE

Under normal continuous exposure the average life expectancy ranges from 18 to 30 months, depending on color.

The information provided herein is based upon data believed to be reliable. All testing is performed in accordance with ASTM standards and procedures. All values are typical and nominal and do not represent either minimum or maximum performance of the product. Although the information is accurate to the best of our knowledge and belief, no representation of warranty or guarantee is made as to the suitability or completeness of such information. Likewise, no representation of warranty or guarantee, expressed or implied, or merchantability, fitness or otherwise, is made as to product application for a particular use.

©2006 REEF INDUSTRIES, INC. Griffolyn is a registered trademark of Reef Industries, Inc. 09-06

TOLLFREE 1.800.231.6074

9209 Almeda Genoa Rd. • Houston, Texas 77075

P: 713.507.4251 • F: 713.507.4295

Email: ri@reefindustries.com



TRANSGUARD® 4000

Reusable Wet Cure Covers

Transguard® 4000 consists of a natural colored polypropylene nonwoven fabric with a 4 mil coating applied to one side. The nonperforated white coating contains ultraviolet light stabilizers providing protection against UV degradation.

PHYSICAL PROPERTIES AND TYPICAL VALUES

PROPERTY	ASTM TEST METHOD	U.S. VALUE	METRIC VALUE
Weight	D-2103	53 LB/1000 FT ²	25.9 KG/100 M ²
Thickness	D-5199	42 MIL	1.1 MM
Grab Tensile	D-4632	170 LBF	756 N
Grab Elongation	D-4632	65 %	65 %
Trapezoidal Tear	D-4533	54 LBF	240 N
Hydraulic Burst	D-3786	190 PSI	1.3 MPA
Water Loss (per 72 hrs.)	C-156	.0205 LBS/FT ²	.1 KG/M ²
Reflectance	E-1347	85 %	85 %
Puncture Strength	D-4833	70 LBS	311 KG

FEATURES

Transguard® 4000 Reusable Wet Cure Covers meet or exceed AASHTO M-171 and ASTM C-171, "Standard Specification for Sheet Materials for Curing Concrete" for moisture retention and reflection.

The information provided herein is based upon data believed to be reliable. All testing is performed in accordance with ASTM standards and procedures. All values are typical and nominal and do not represent either minimum or maximum performance of the product. Although the information is accurate to the best of our knowledge and belief, no representation of warranty or guarantee is made as to the suitability or completeness of such information. Likewise, no representation of warranty or guarantee, expressed or implied, or merchantability, fitness or otherwise, is made as to product application for a particular use.

©2006 REEF INDUSTRIES, INC. Armorlon and Transguard are registered trademarks of Reef Industries, Inc. 09-06

TOLLFREE 1.800.231.6074

9209 Alameda Genoa Rd. • Houston, Texas 77075

P: 713.507.4251 • F: 713.507.4295

Email: ri@reefindustries.com

REEF INDUSTRIES, INC.

The Manufacturing Leader of Specialized Industrial Plastic Films Since 1957.

TRANSGUARD® 4000

ARMORLON®

PRODUCT INFORMATION • SPECIFICATION GUIDE



10 MIL GREEN

Griffolyn® 10 mil is a co-extruded polyolefin membrane containing the latest polymer technology, resulting in superior puncture resistance, impact and tensile strength. It is specifically engineered to provide high strength and durability in a vapor retarder.

ASTM E-1745-97 REQUIREMENTS

CRITERIA	ASTM TEST METHOD	CLASS A	CLASS B	GRIFFOYLN® 10 MIL
Water Vapor Permeance	E-96 / F - 1249	0.3 PERMS	0.3 PERMS	0.027 PERMS
Tensile Strength	D-882	45.0 LBF/in.	30 LBF/in.	45 LBF/in.
Puncture Resistance	D-1709	2200 g	1700 g	2250 g

PHYSICAL PROPERTIES AND TYPICAL VALUES

PROPERTY	ASTM TEST METHOD	U.S. VALUE	METRIC VALUE
Roll Weight	D-2103	110 LBS	50 KG
Roll Size		12' x 200'	3.65 M x 61 M
1" Load @ Break	D-882	45 LBF	200 N
		4500 PSI	31 MPA
3" Elongation @ Break	D-882	600 %	600 %
Tongue Tear	D-2261	11.5 LBF	51 N
Dart Impact Strength	D-1709	5 LBS	2250 g
Permeance	E-96	0.027 Grain/Hr•Ft ² •in.Hg	1.549 NG/(PA•S•M ²)
PPT Resistnace	D-2582	35 LBF	156 N

FEATURES

- Class A and Class B, ASTM E-1745-97 Standard Specification for Water Vapor Retarders Used in Contact With Soil or Granular Fill Under Concrete Slabs.
- Low permeability greatly inhibits moisture transmission.
- Flexibility allows for easy handling and quick installation.
- Cold-crack resistance eliminates failures in extremely cold temperatures.

The information provided herein is based upon data believed to be reliable. All testing is performed in accordance with ASTM standards and procedures. All values are typical and nominal and do not represent either minimum or maximum performance of the product. Although the information is accurate to the best of our knowledge and belief, no representation of warranty or guarantee is made as to the suitability or completeness of such information. Likewise, no representation of warranty or guarantee, expressed or implied, or merchantability, fitness or otherwise, is made as to product application for a particular use.

©2006 REEF INDUSTRIES, INC. Griffolyn is a registered trademark of Reef Industries, Inc. 09-06

TOLLFREE 1.800.231.6074

9209 Alameda Genoa Rd. • Houston, Texas 77075

P: 713.507.4251 • F: 713.507.4295

Email: ri@reefindustries.com

REEF INDUSTRIES, INC.

The Manufacturing Leader of Specialized Industrial Plastic Films Since 1957.

10 MIL GREEN

GRIFFOYLN®

PRODUCT INFORMATION • SPECIFICATION GUIDE



15 MIL GREEN

Griffolyn® 15 mil is a co-extruded polyolefin membrane containing the latest polymer technology, resulting in superior puncture resistance, impact and tensile strength. It is specifically engineered to provide high strength and durability in a vapor retarder.

ASTM E-1745-97 REQUIREMENTS

CRITERIA	ASTM TEST METHOD	CLASS A	GRIFFOYLN® 15 MIL
Water Vapor Permeance	E-96 / F-1249	0.3 PERMS	0.018 PERMS
Tensile Strength	D-882	45.0 LBF/in.	60 LBF/in.
Puncture Resistance	D-1709	2200 g	3100 g

PHYSICAL PROPERTIES AND TYPICAL VALUES

PROPERTY	ASTM TEST METHOD	U.S. VALUE	METRIC VALUE
Roll Weight	D-2103	125 LBS	57 KG
Roll Size		12' x 150'	3.65 M x 45.7 M
1" Load @ Break	D-882	60 LBF	267 N
		4000 PSI	27.7 MPA
3" Elongation @ Break	D-882	580 %	580 %
Tongue Tear	D-2261	24 LBF	107 N
Dart Impact Strength	D-1709	7 LBS	3100 g
Permeance	E-96	0.018 Grain/Hr•Ft ² •in.Hg	1.032 NG/(PA•S•M ²)
PPT Resistnace	D-2582	47 LBF	209 N

FEATURES

- Class A, ASTM E-1745-97 Standard Specification for Water Vapor Retarders Used in Contact With Soil or Granular Fill Under Concrete Slabs.
- Low permeability greatly inhibits moisture transmission.
- Flexibility allows for easy handling and quick installation.
- Cold-crack resistance eliminates failures in extremely cold temperatures.

The information provided herein is based upon data believed to be reliable. All testing is performed in accordance with ASTM standards and procedures. All values are typical and nominal and do not represent either minimum or maximum performance of the product. Although the information is accurate to the best of our knowledge and belief, no representation of warranty or guarantee is made as to the suitability or completeness of such information. Likewise, no representation of warranty or guarantee, expressed or implied, or merchantability, fitness or otherwise, is made as to product application for a particular use.

©2006 REEF INDUSTRIES, INC. Griffolyn is a registered trademark of Reef Industries, Inc. 09-06

TOLLFREE 1.800.231.6074

9209 Alameda Genoa Rd. • Houston, Texas 77075

P: 713.507.4251 • F: 713.507.4295

Email: ri@reefindustries.com

REEF INDUSTRIES, INC.

The Manufacturing Leader of Specialized Industrial Plastic Films Since 1957.

15 MIL GREEN

GRIFFOYLN®

PRODUCT INFORMATION • SPECIFICATION GUIDE





WATER VAPOR TRANSMISSION DEFINITIONS AND CONVERSION FACTORS

Water Vapor Transmission Rate (WVTR)

The steady water vapor flow in unit time through unit area of a body, normal to specific parallel surfaces, under specific conditions of temperature and humidity at each surface.

$WVT = G/tA$

G = weight change; t = time; and A = surface area

Units: grains / h(ft²)
G / h(m²)

Conversion factors

Grains / h • ft² x 0.697 = g/h • m²
g/h • m² x 1.43 = grains/h • ft²

Water Vapor Permeance

The time rate of water vapor transmission through unit area of flat material or constructions induced by unit vapor pressure difference between two specific surfaces, under specified temperature and humidity conditions. Permeance is a performance evaluation of a material, not a property.

Permeance = WVT/Dp = WVT/S(R1-R2)

Dp = vapor pressure difference

S = saturation vapor pressure at test temperature

R1 = RH at the source R2 = at the vapor sink

Units: 1 perm = 1.00 grains/h • ft² • in Hg
= 5.72E-08 g/Pa • s • m²
= 2.74E-02 g/h • m² • mm Hg

Conversion factors

Perms x 5.72E-08 = g/Pa • s • m²
G/Pa • s • m² x 1.75E-07 = Perms
Mm Hg = 1.333E-02 Pa

Water Vapor Permeability

The time rate of water vapor transmission through unit area of a flat material of unit area induced by unit vapor pressure difference between two specific surfaces under specified temperature and humidity conditions. Permeability is a property of a material.

Permeability = Permeance x Thickness

Units Perm-inches = grains • in/h • ft² in Hg
= 6.88E-10 g/Pa • s • m

Conversion Factors

Perm-inches x 1.45E-08 = g/Pa • s • m
G/Pa • s • m x 6.88E-10 = Perm-inches

Fab Tape™ is a double sided asphaltic mastic tape. It is available in black.

PHYSICAL PROPERTIES AND TYPICAL VALUES

PROPERTY	U.S. VALUE	METRIC VALUE
Thickness	35 Mils	.9 MM
Width	1.5 In.	38 MM
Roll Length	100 Ft.	30.5 M
Roll Weight	3.75 LBS	1.7 KG
Specific Gravity	1.4	1.4
Solubility in Water	Insoluble	Insoluble
T-55 Black 3" Peel	19 LBS	84.5 N
TX-1200 Black 3" Shear	31 LBS	138 N
Temperature for Testing Above	50° - 95° F	10° - 35° C

INSTALLATION

The surface to be taped should be clean and dry. The tape will not adhere if the surfaces are not properly prepared. Dirty or wet surfaces should be completely cleaned with water, paper towels, dry rags or other materials which will prepare the surface for the tape. Accumulations of dust should also be removed to insure a secure seam.

The product obtains optimum adhesion when the surfaces to be bonded are warm. The surfaces should be above 50-60°F to insure an acceptable bond. In order to obtain a bond at lower temperatures, external heat may be required. The use of an industrial style hot air blower is one recommended method. Extra care should be taken when attempting to install tape at temperatures below 32°F.

The information provided herein is based upon data believed to be reliable. All testing is performed in accordance with ASTM standards and procedures. All values are typical and nominal and do not represent either minimum or maximum performance of the product. Although the information is accurate to the best of our knowledge and belief, no representation of warranty or guarantee is made as to the suitability or completeness of such information. Likewise, no representation of warranty or guarantee, expressed or implied, or merchantability, fitness or otherwise, is made as to product application for a particular use.

TOLLFREE 1.800.231.6074

9209 Alameda Genoa Rd. • Houston, Texas 77075
 P: 713.507.4251 • F: 713.507.4295
 Email: ri@reefindustries.com



Griffolyn® Griff Tape™ is an adhesive backed tape. It is available in two colors: black or white.

PHYSICAL PROPERTIES AND TYPICAL VALUES

PROPERTY	U.S. VALUE	METRIC VALUE
Roll Length	180 Ft	55 M
Width	4 IN	100 MM
Adhesion to Steel	38 OZ/IN	11 G/MM
Elongation	20 %	20 %
Gauge	11 MILS	.28 MM
Tensile 1"	25 LBS	111 N
Unwind 1"	2.5 LBS	11 N
Max. Performance Temperature	200°F	93°C
Fire Retardancy E-84	5 flame spread, 0 smoke developed, 0 fuel contribution	

INSTALLATION

The surface to be taped should be clean and dry. The tape will not adhere if the surfaces are not properly prepared. Dirty or wet surfaces should be completely cleaned with water, paper towels, dry rags or other materials which will prepare the surface for the tape. Accumulations of dust should also be removed to insure a secure seam.

The product obtains optimum adhesion when the surfaces to be bonded are warm. The surfaces should be above 50-60°F to insure an acceptable bond. In order to obtain a bond at lower temperatures, external heat may be required. The use of an industrial style hot air blower is one recommended method. Extra care should be taken when attempting to install tape at temperatures below 32°F.

The information provided herein is based upon data believed to be reliable. All testing is performed in accordance with ASTM standards and procedures. All values are typical and nominal and do not represent either minimum or maximum performance of the product. Although the information is accurate to the best of our knowledge and belief, no representation of warranty or guarantee is made as to the suitability or completeness of such information. Likewise, no representation of warranty or guarantee, expressed or implied, or merchantability, fitness or otherwise, is made as to product application for a particular use.

©2006 REEF INDUSTRIES, INC. Fab Tape is a trademark of Reef Industries, Inc. 09-06

TOLLFREE 1.800.231.6074

9209 Alameda Genoa Rd. • Houston, Texas 77075

P: 713.507.4251 • F: 713.507.4295

Email: ri@reefindustries.com



Griffolyn® Griff Tape™ FR is a fire retardant pressure sensitive tape. Tape color is white.

PHYSICAL PROPERTIES AND TYPICAL VALUES

PROPERTY	U.S. VALUE	METRIC VALUE
Roll Length	180 Ft	55 M
Roll Weight	3.75 LBS	1.7 KG
Width	4 IN	100 MM
Adhesion to Steel	66 OZ/IN	72 G/MM
Adhesion to Backing	41 OZ/IN	45.9 KG/CM
Tensile Strength	26 LBS/IN	4.5 KG/CM
FR Rating: Vertical Burn Time 60 Sec.	0.5 Sec.	0.5 Sec.
Vertical Burn Drip 60 Sec.	No Drip	No Drip
Vertical Burn Length 60 Sec.	5 IN	127 MM

INSTALLATION

The surface to be taped should be clean and dry. The tape will not adhere if the surfaces are not properly prepared. Dirty or wet surfaces should be completely cleaned with water, paper towels, dry rags or other materials which will prepare the surface for the tape. Accumulations of dust should also be removed to insure a secure seam.

The product obtains optimum adhesion when the surfaces to be bonded are warm. The surfaces should be above 40°F to insure an acceptable bond. In order to obtain a bond at lower temperatures, external heat may be required. The use of an industrial style hot air blower is one recommended method. Extra care should be taken when attempting to install tape at temperatures below 32°F.

The information provided herein is based upon data believed to be reliable. All testing is performed in accordance with ASTM standards and procedures. All values are typical and nominal and do not represent either minimum or maximum performance of the product. Although the information is accurate to the best of our knowledge and belief, no representation of warranty or guarantee is made as to the suitability or completeness of such information. Likewise, no representation of warranty or guarantee, expressed or implied, or merchantability, fitness or otherwise, is made as to product application for a particular use.

©2006 REEF INDUSTRIES, INC. Fab Tape is a trademark of Reef Industries, Inc. 09-06

TOLLFREE 1.800.231.6074

9209 Alameda Genoa Rd. • Houston, Texas 77075

P: 713.507.4251 • F: 713.507.4295

Email: ri@reefindustries.com



3" DIA O.D. PIPE
MAXIMUM

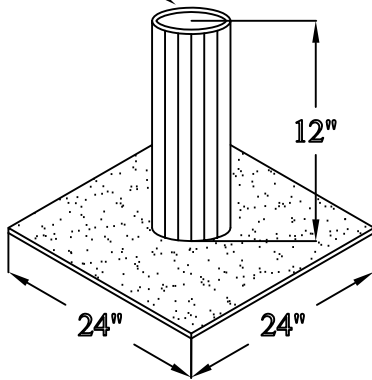

REEF INDUSTRIES PART NO: 60-0075

PIPEBOOTS ARE MADE FROM GRIFFOLYN MATERIAL. THE 5" LAYFLAT (3" DIA) PIPEBOOT IS DESIGNED TO FIT PIPES RANGING FROM 1/2" TO 2-1/2" IN DIAMETER INCLUDES 24" x 24" APRON

5" DIA O.D. PIPE
MAXIMUM

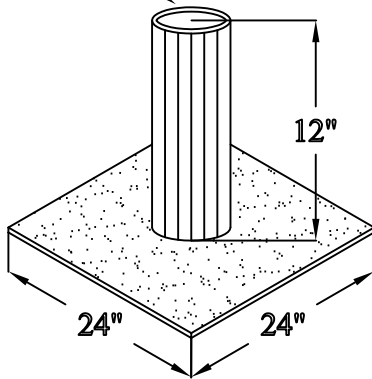

REEF INDUSTRIES PART NO: 60-0076

PIPEBOOTS ARE MADE FROM GRIFFOLYN MATERIAL. THE 8" LAYFLAT (5" DIA) PIPEBOOT IS DESIGNED TO FIT PIPES RANGING FROM 2-1/2" TO 4-1/2" DIA. INCLUDES 24" x 24" APRON

8" DIA O.D. PIPE
MAXIMUM

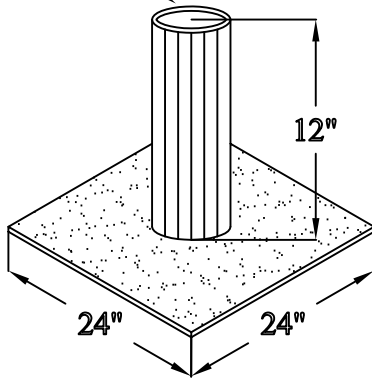

REEF INDUSTRIES PART NO: 60-0116

PIPEBOOTS ARE MADE FROM GRIFFOLYN MATERIAL. THE 14" LAYFLAT (8" DIA) PIPEBOOT IS DESIGNED TO FIT PIPES RANGING FROM 4-1/2" TO 8" DIA. INCLUDES 24" x 24" APRON

09-15-03 V: 2.0

NOTE: This document provides information related to the installation of "pipeboots" and its components. This document does not attempt to address all aspects of an installation for all application. The information presented is general information in order to familiarize the individual with the overall scope of the project.

DWG 1 OF 3

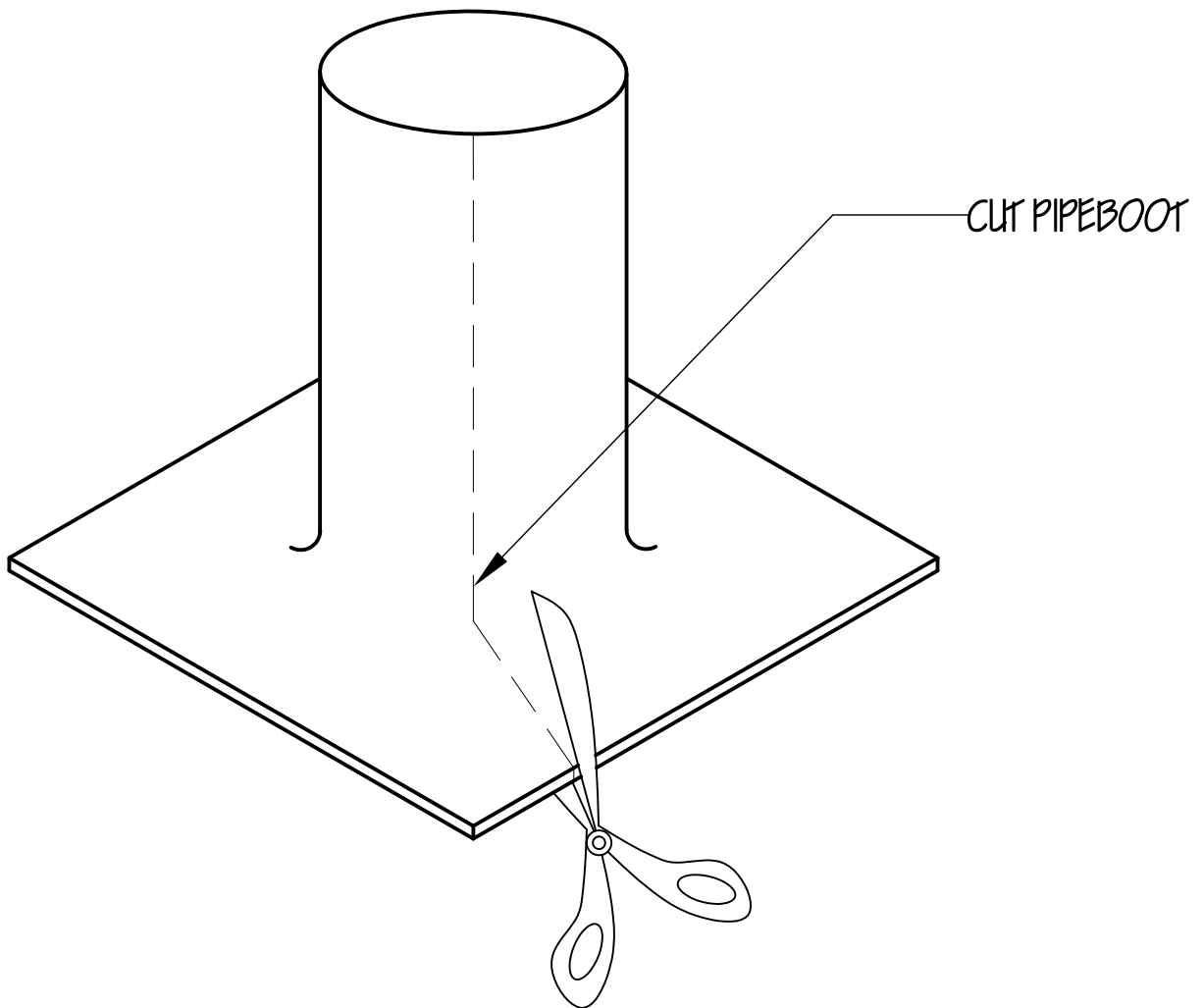

STEP 1

CUT PIPEBOOT OPEN

12-18-2002 V 1.0

NOTE: This document provides information related to the installation of "pipeboots" and it's components. This document does not attempt to address all aspects of an installation for all application. The information presented is general information in order to familiarize the individual with the overall scope of the project.

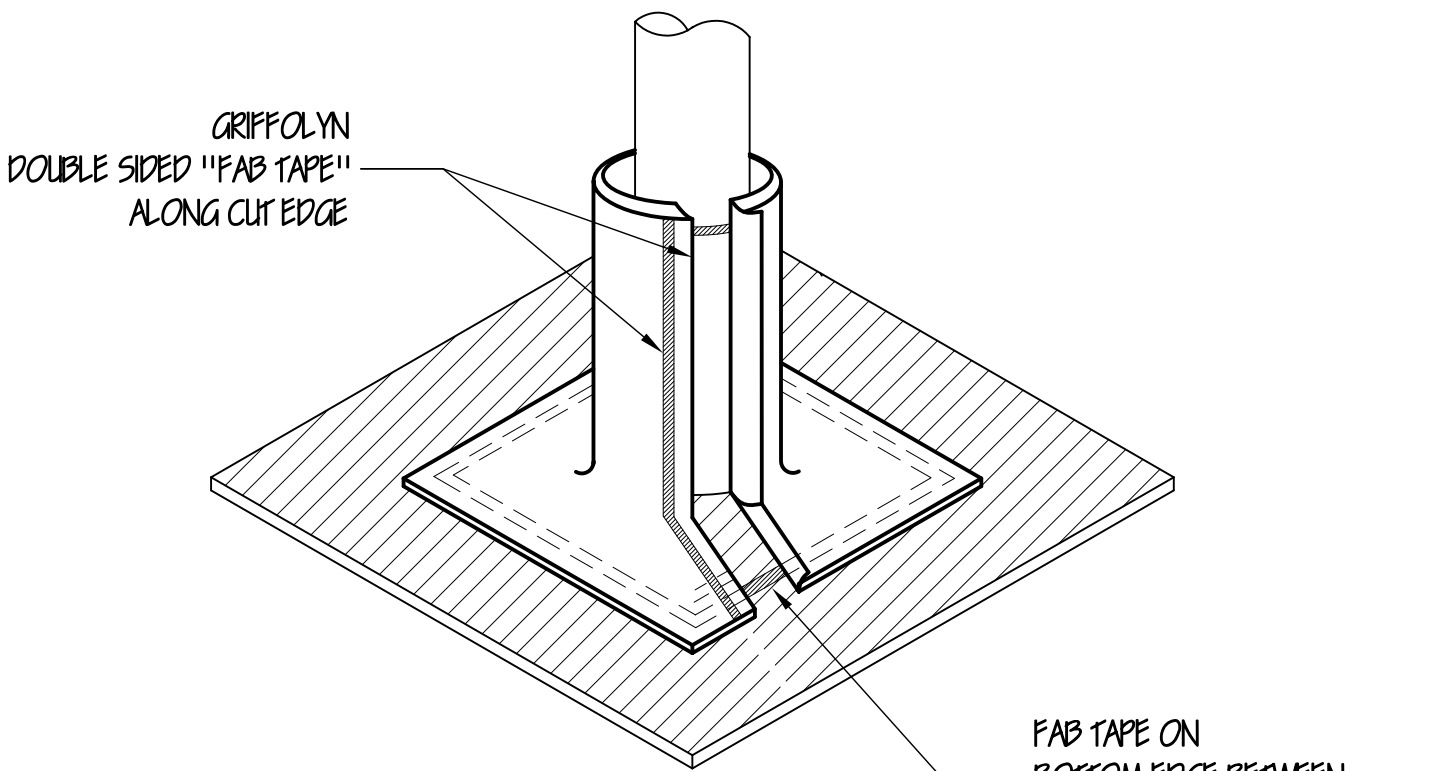

STEP 2
AFTER PIPEBOOT IS CUT, APPLY DOUBLE
SIDED GRIFFOLYN "FAB TAPE" ADJACENT TO
CUT EDGE OF PIPEBOOT AND (1) ROW AROUND
PIPE BELOW TOP EDGE OF PIPEBOOT

12-18-2002 V1.0

NOTE: This document provides information related to the installation of "pipeboots" and it's components. This document does not attempt to address all aspects of an installation for all application. The information presented is general information in order to familiarize the individual with the overall scope of the project.

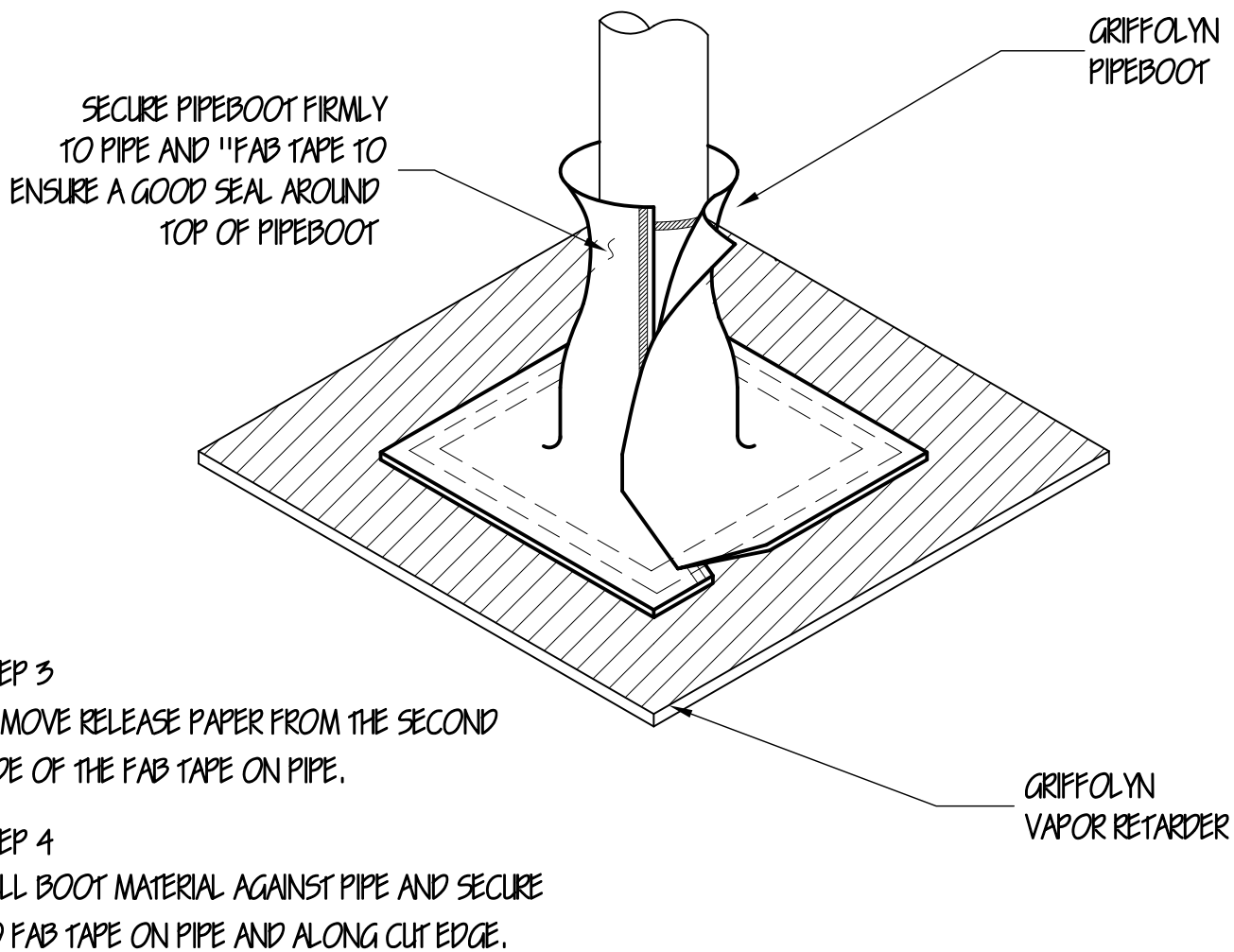

12-18-2002 V1.0

NOTE: This document provides information related to the installation of "pipeboots" and it's components. This document does not attempt to address all aspects of an installation for all application. The information presented is general information in order to familiarize the individual with the overall scope of the project.

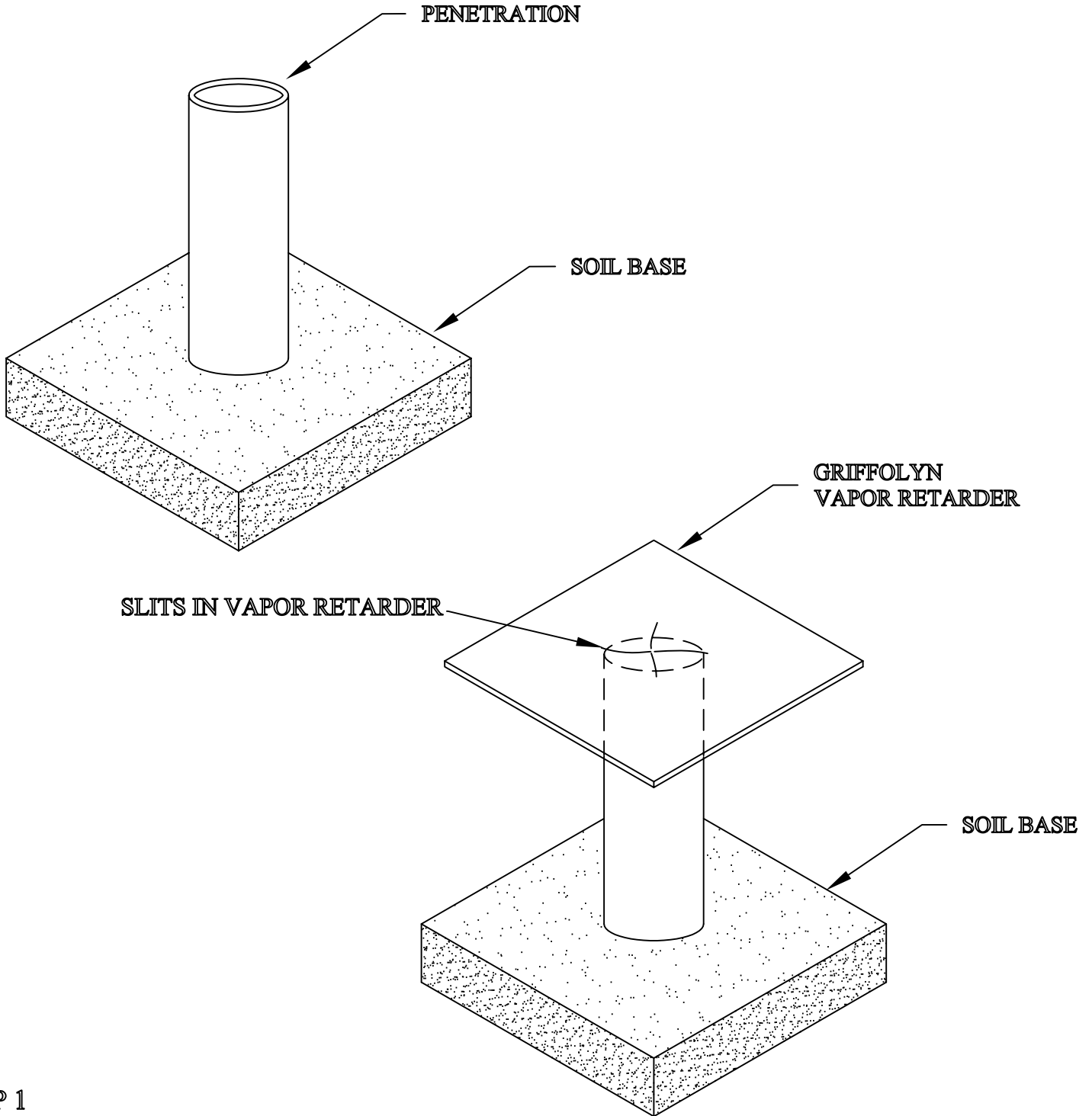

STEP 1

- A. PLACE VAPOR RETARDER OVER PENETRATION
- B. CUT AN OPENING AS SMALL AS PRACTICAL IN THE VAPOR RETARDER.

12-13-02 V: 1.0

NOTE: This document provides information related to the installation of "pipeboots" and its components. This document does not attempt to address all aspects of an installation for all application. The information presented is general information in order to familiarize the individual with the overall scope of the project.

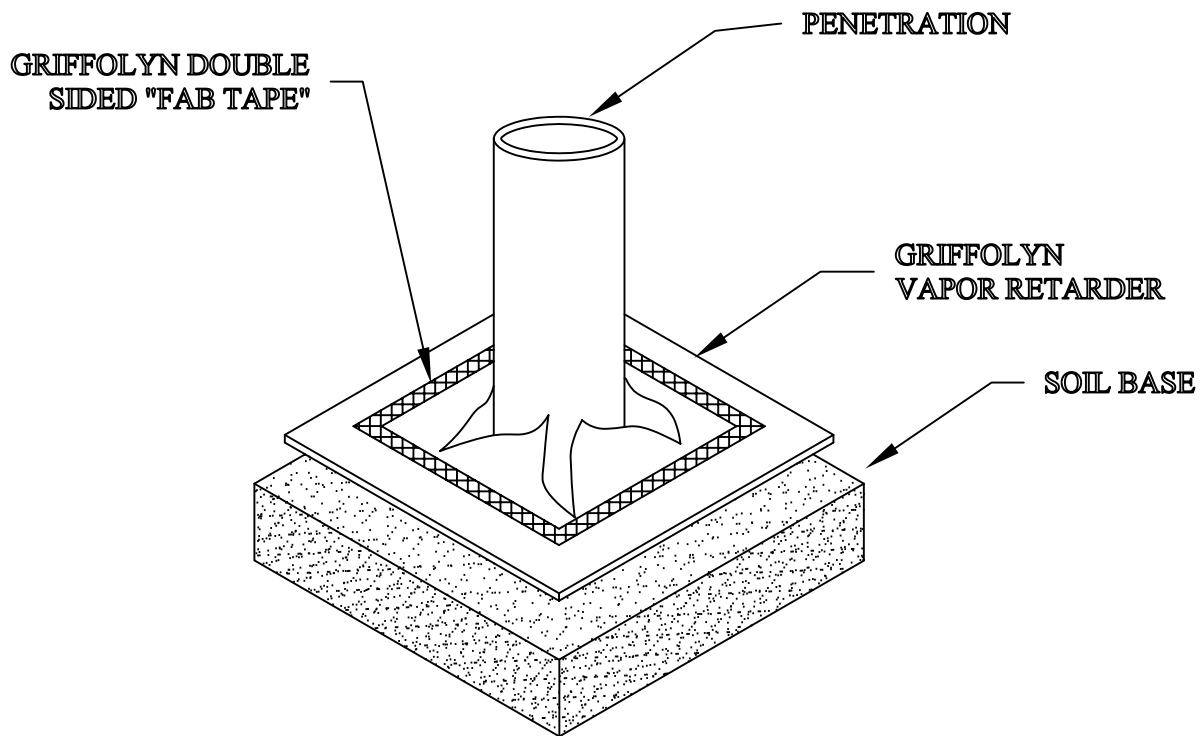

NOTE:
ALL SURFACE AREAS WHERE TAPE WILL BE APPLIED SHOULD BE CLEAN AND DRY.

STEP 2

- A. PLACE DOUBLE SIDED FAB TAPE ON AREAS AS INDICATED.
- B. LEAVE RELEASE PAPER ON FABTAPE.

12-13-02 V: 1.0

NOTE: This document provides information related to the installation of "pipeboots" and its components. This document does not attempt to address all aspects of an installation for all application. The information presented is general information in order to familiarize the individual with the overall scope of the project.

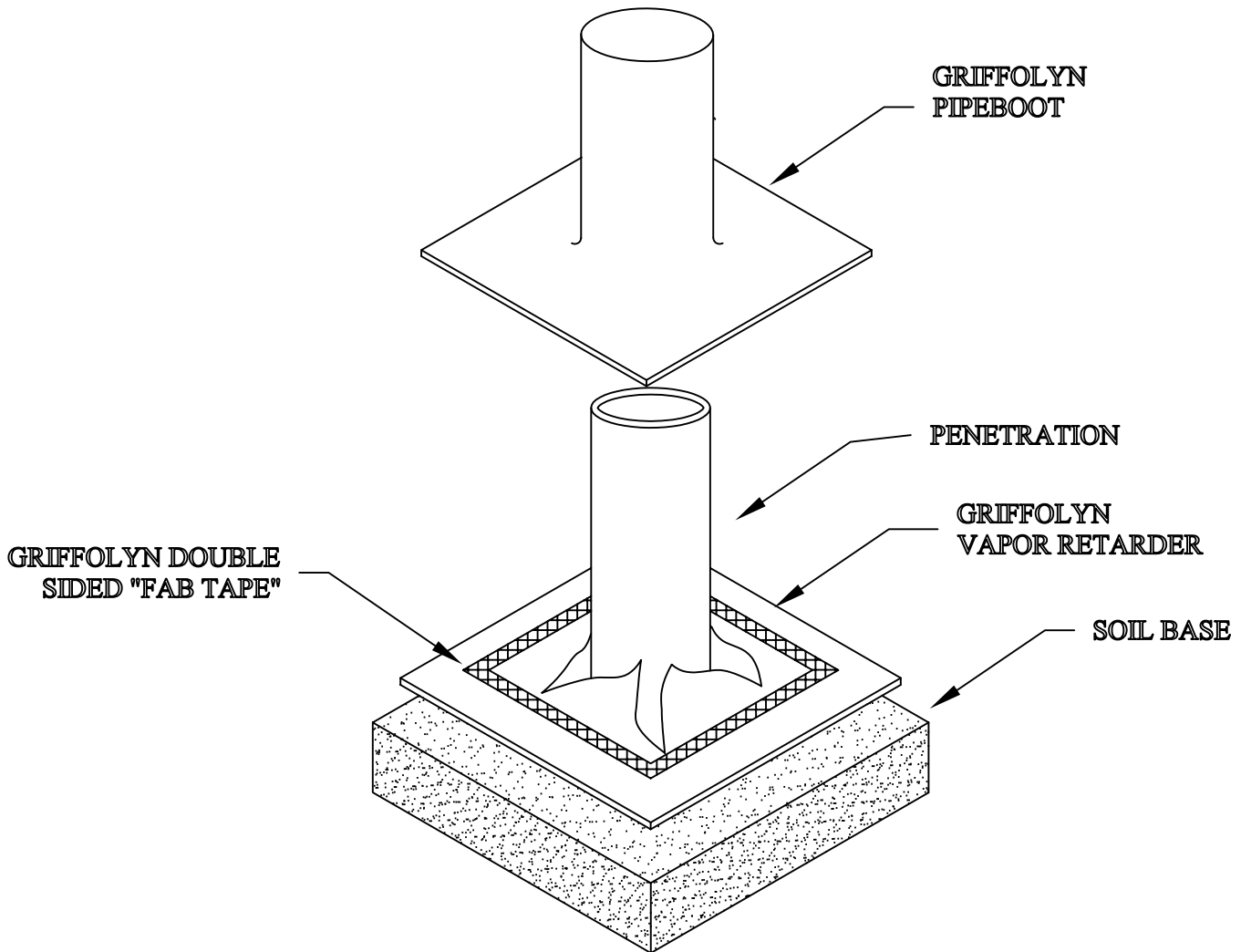

STEP 3

- A. PLACE PIPEBOOT OVER PENETRATION.
- B. FLATTEN BASE OF PIPEBOOT OVER LINER AND FABTAPE
- C. LIFT OUTER EDGES OF BOOT AND REMOVE RELEASE PAPER FROM FAB TAPE AND
- D. SECURE PIPEBOOT TO FAB TAPE

12-13-02 V: 1.0

NOTE: This document provides information related to the installation of "pipeboots" and it's components. This document does not attempt to address all aspects of an installation for all application. The information presented is general information in order to familiarize the individual with the overall scope of the project.

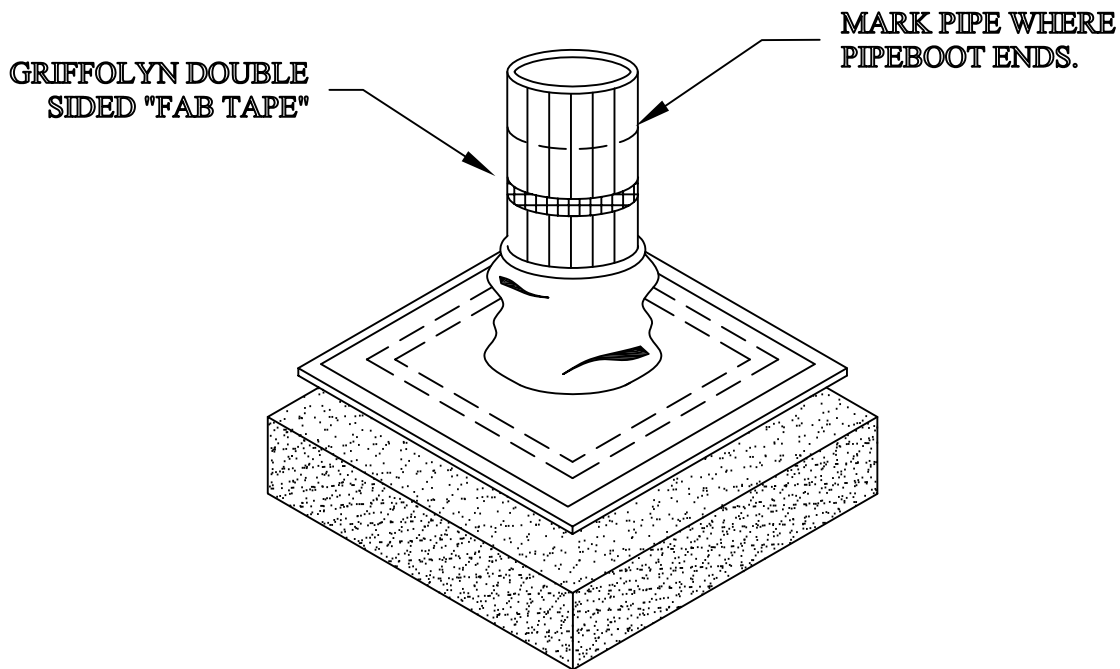

STEP 4

A. MARK TOP EDGE OF PIPEBOOT ON PIPE AND SLIDE BOOT DOWN APPROX. 4 INCHES.

B. PLACE THE FAB TAPE APPROX 2" BELOW THE MARK ON THE PIPE

12-13-02 V: 1.0

NOTE: This document provides information related to the installation of "pipeboots" and it's components. This document does not attempt to address all aspects of an installation for all application. The information presented is general information in order to familiarize the individual with the overall scope of the project.

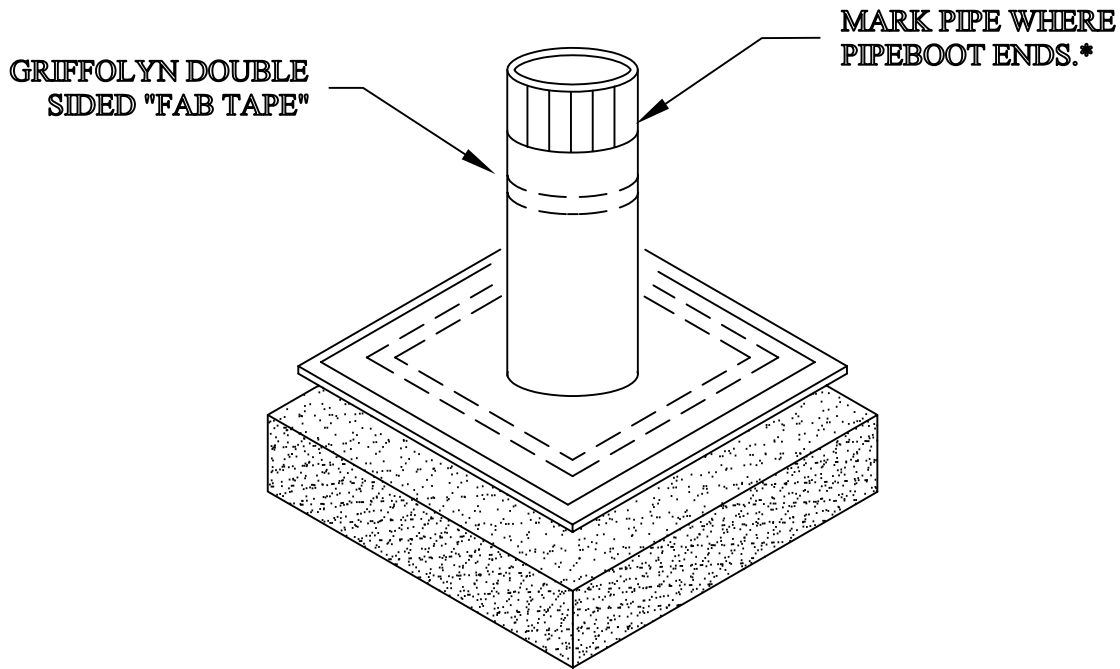

STEP 5

- A. REMOVE THE RELEASE PAPER FROM THE FAB TAPE
- B. PULL BOOT UP AROUND FAB TAPE AND SECURE BOOT TO TAPE.

NOTE:

TAKE CARE TO SEAL THE PIPEBOOT TO THE VAPOR RETARDER AND TO THE PIPE
IT MAY BE NECESSARY TO SHORTEN THE PIPEBOOT
TO ACCOMODATE PLUMBING FITTINGS, HOWEVER THE
TOP EDGE OF THE BOOT SHOULD BE AT/ABOVE SLAB LEVEL.

12-13-02 V: 1.0

NOTE: This document provides information related to the installation of "pipeboots" and it's components. This document does not attempt to address all aspects of an installation for all application. The information presented is general information in order to familiarize the individual with the overall scope of the project.

Installation Instructions for the Use of Fab Tape™

Fab Tape™ is an asphaltic mastic which creates a durable field seam around penetrations in the material and effectively joins multiple sheets of Griffolyn® Vapor Retarders. Proper installation is imperative to ensure the integrity of the bond.

Both Griffolyn surfaces must be absolutely clean and dry.

Fab Tape adheres better to sand and dust than to polyethylene. Water creates pockets which can thermally expand and contract sufficiently to degrade adhesion and destroy the seal. When exposed to sunlight, black Griffolyn can reach temperatures of up to 170°F. Clean thoroughly with mild soap, rinse with clean water and dry completely with a hot air device for best results.

Warm polyethylene surfaces promote better initial adhesion.

It takes about 24 hours in a warm environment for Fab Tape to reach maximum bond strength. When the ambient temperature falls below 60°F the time is extended unless additional heat sources are employed.

Proper grading of the substrate beneath the Griffolyn Vapor Retarder is essential for optimal sealing.

A rough, rutted and/or lumpy subgrade can cause wrinkles and gaps which will inhibit the bonding process.

To begin installation, lay both sheets over a smooth subgrade with a 6" or more overlap. Apply the Fab Tape 4" back from and parallel to the edge of the bottom sheet. Be sure to smooth out any gaps or voids while applying the tape. If a double seam is required, increase the overlap to 12" and run the second row of tape parallel to and 4" to 6" away from the first row before sealing the first seam.

Remove the release paper to expose the second adhesive side and firmly press the top sheet to the bottom one while maintaining even tension on both sheets. Uneven tension can cause gaps and voids which will prevent proper bonding and cause leaks.

Firm hand pressure is sufficient for initial adhesion on warm sunny days. After 24 hours the bond is permanently set. Overcast conditions and/or temperatures of less than 60°F will require additional heat, pressure and time to bond completely. A veneer proofing roller is very effective for applying additional pressure when the Griffolyn Vapor Retarder is installed over a smooth subgrade.

Allow adequate time for complete bonding before subjecting the joint to substantial stress.

**Call 1-800-231-6074 for answers
to your installation questions.**

Reef Industries, Inc. 9209 Almeda Genoa Rd. Houston, TX 77075
USA Toll Free 800-231-6074 Tel: 713-507-4251 Fax: 713-507-4295
www.reefindustries.com ri@reefindustries.com



Call today for
technical assistance
or to place your order.

800/231-6074

9209 Almeda Genoa
Houston, Tx 77075

Tel: 713.507.4251
Fax: 713.507.4295

Reef Industries, Inc.
9209 Almeda Genoa Rd.
Houston, Texas 77075
Toll Free (800) 231-6074
Phone (713) 507-4251
Fax (713) 507-4295
Web Site www.reefindustries.com
E-Mail ri@reefindustries.com

Product Guide Specification

Specifier Notes: This product guide specification is written according to the Construction Specifications Institute (CSI) Format, including *MasterFormat* (1995 Edition), *SectionFormat*, and *PageFormat*, contained in the *CSI Manual of Practice*.

The section must be carefully reviewed and edited by the Architect to meet the requirements of the project and local building code. Coordinate this section with other specification sections and the drawings.

Delete all "Specifier Notes" when editing this section.

SECTION 07260

REINFORCED VAPOR RETARDERS FOR UNDER SLABS

Specifier Notes: This section covers Reef Industries, Inc. "Griffolyn" reinforced vapor retarders for under concrete slab applications.

To prepare a "Short Form" version of this section, delete Articles 1.2 Related Sections, 1.3 References, and 1.5 Quality Assurance. Renumber remaining articles in Part 1.

Consult Reef Industries for assistance in editing this section for the specific application.

PART 1 GENERAL

1.1 SECTION INCLUDES

- A. Reinforced vapor retarders for under concrete slab applications.

1.2 RELATED SECTIONS

Specifier Notes: Edit the following list as required for the project. List other sections with work directly related to the reinforced vapor retarders.

- A. Section 02300 - Earthwork: Subgrade below reinforced vapor retarders.
- B. Section 03300 - Cast-in-Place Concrete.

- C. Section 09620 - Specialty Flooring.
- D. Section 09640 - Wood Flooring.
- E. Section 09650 - Resilient Flooring.
- F. Section 09660 - Static Control Flooring.
- G. Section 09670 - Fluid-Applied Flooring.
- H. Section 09680 - Carpet.

1.3 REFERENCES

Specifier Notes: List standards referenced in this section, complete with designations and titles. This article does not require compliance with standards, but is merely a listing of those used.

- A. ASTM D 882 - Tensile Properties of Thin Plastic Sheeting.
- B. ASTM D 1709 - Impact Resistance of Plastic Film by the Free-Falling Dart Method.
- C. ASTM D 2582 - Puncture-Propagation Tear Resistance of Plastic Film and Thin Sheeting.
- D. ASTM D 3776 - Mass per Unit Area (Weight) of Woven Fabric.
- E. ASTM D 4833 - Index Puncture Resistance of Geotextiles, Geomembranes, and Related Products.
- F. ASTM E 96 - Water Vapor Transmission of Materials.
- G. ASTM E 1643 - Installation of Water Vapor Retarders Used in Contact with Earth or Granular Fill Under Concrete Slabs.
- H. ASTM E 1745 - Water Vapor Retarders Used in Contact with Soil or Granular Fill Under Concrete Slabs.

1.4 SUBMITTALS

- A. Comply with Section 01330 - Submittal Procedures.
- B. Product Data: Submit manufacturer's product data, including installation instructions.
- C. Samples: Submit manufacturer's samples of reinforced vapor retarders.

1.5 QUALITY ASSURANCE

Specifier Notes: Describe requirements for a meeting to coordinate the installation of the reinforced vapor retarders and to sequence related work. Delete this paragraph if not required.

- A. Preinstallation Meeting: Convene a preinstallation meeting [2] [_____] weeks before start of installation of reinforced vapor retarders. Require attendance of parties directly affecting

work of this section, including Contractor, Architect, and installer. Review installation, protection, and coordination with other work.

1.6 DELIVERY, STORAGE, AND HANDLING

- A. Delivery: Deliver materials to site in manufacturer's original, unopened containers and packaging, with labels clearly identifying product name and manufacturer.
- B. Storage: Store materials in a clean, dry area in accordance with manufacturer's instructions.
- C. Handling: Protect materials during handling and installation to prevent damage.

PART 2 PRODUCTS

2.1 MANUFACTURER

- A. Reef Industries, Inc., 9209 Almeda Genoa Rd., Houston, Texas 77075.
Toll Free (800) 231-6074. Phone (713) 507-4251. Fax (713) 507-4295.
Web Site www.reefindustries.com. E-Mail ri@reefindustries.com.

2.2 REINFORCED VAPOR RETARDERS FOR UNDER CONCRETE SLABS

Specifier Notes: Consult Reef Industries for assistance in determining the required reinforced vapor retarder for the specific under slab application. Delete vapor retarders not required.

- A. Reinforced Vapor Retarder: Griffolyn Type-65.
 - 1. Material: 3-ply laminate, combining 2 layers of high-density polyethylene and 1 high-strength non-woven cord grid.
 - 2. Weight, ASTM D 3776: 37 lb/1,000 ft² (18.1 kg/100 m²).
 - 3. Puncture Propagation Tear, ASTM D 2582: 28 lb (124 N).
 - 4. Permeance (Perm), ASTM E 96: 0.038 grains/hr-ft²-in Hg (2.18 ng/(Pa-s-m²)).
 - 5. Drop Dart, ASTM D 1709 Method B: 500 g.
 - 6. Tensile Strength, 3 Inches, ASTM D 882: 96 lb/5,442 psi (427 N/37,522 kPa).
 - 7. Puncture Strength, ASTM D 4833: 24 lb (106 N).
 - 8. Classification, ASTM E 1745: Class C.
 - 9. Usable Temperature Range: -25 to 170 degrees F (-32 to 77 degrees C).
- B. Reinforced Vapor Retarder: Griffolyn Type-85.
 - 1. Material: 5-ply laminate, combining 3 layers of high-density polyethylene and 2 high-strength non-woven cord grids.
 - 2. Weight, ASTM D 3776: 70 lb/1,000 ft² (34.2 kg/100 m²).
 - 3. Puncture Propagation Tear, ASTM D 2582: 40 lb (178 N).
 - 4. Permeance (Perm), ASTM E 96: 0.027 grains/hr-ft²-in Hg (1.551 ng/(Pa-s-m²)).
 - 5. Drop Dart, ASTM D 1709: 1,900 g.
 - 6. Tensile Strength, 3 Inches, ASTM D 882: 225 lb/3846 psi (1000 N/26,515 kPa).
 - 7. Puncture Strength, ASTM D 4833: 50 lb (222 N).
 - 8. Classification, ASTM E 1745: Class B.
 - 9. Usable Temperature Range: -40 to 170 degrees F (-40 to 77 degrees C).
- C. Reinforced Vapor Retarder: Griffolyn Type-105.
 - 1. Material: 7-ply laminate, combining 4 layers of high-density polyethylene and 3 high-

strength non-woven cord grids.

2. Weight, ASTM D 3776: 82 lb/1,000 ft² (40 kg/100 m²).
3. Puncture Propagation Tear, ASTM D 2582: 45 lb (200 N).
4. Permeance (Perm), ASTM E 96: 0.021 grains/hr-ft²-in Hg (1.207 ng/(Pa-s-m²)).
5. Drop Dart, ASTM D 1709: 2,300 g.
6. Tensile Strength, 3 Inches, ASTM D 882: 275 lb/5,464 psi (1,223 N/37,674 kPa).
7. Puncture Strength, ASTM D 4833: 72 lb (320 N).
8. Classification, ASTM E 1745: Class A.
9. Usable Temperature Range: -45 to 170 degrees F (-42 to 77 degrees C).

D. Reinforced Vapor Retarder: Griffolyn Vaporguard.

1. Material: 3-ply laminate, with an aluminum core surrounded by 2 layers of multi-axially oriented, high-density polyethylene sheets.
2. Weight, ASTM D 3776: 70 lb/1,000 ft² (34.2 kg/100 m²).
3. Puncture Propagation Tear, ASTM D 2582: 15 lb (68 N).
4. Permeance (Perm), ASTM E 96: 0.000 grains/hr-ft²-in Hg (0.000 ng/(Pa-s-m²)).
5. Drop Dart, ASTM D 1709: 590 g.
6. Tensile Strength, 3 Inches, ASTM D 882: 100 lb/2,200 psi (448 N/15,160 kPa).
7. Puncture Strength, ASTM D 4833: 42 lb (187 N).
8. Classification, ASTM E 1745: Class C.
9. Usable Temperature Range: -40 to 170 degrees F (-40 to 77 degrees C).

E. Reinforced Vapor Retarder: Griffolyn Type-65 G.

1. Material: 4-ply laminate, combining 2 layers of high-density polyethylene and a high-strength non-woven cord grid with a layer of non-woven geotextile fiber.
2. Weight, ASTM D 3776: 80 lb/1,000 ft² (39 kg/100 m²).
3. Puncture Propagation Tear, ASTM D 2582: 55 lb (245 N).
4. Permeance (Perm), ASTM E 96: 0.038 grains/hr-ft²-in Hg (2.18 ng/(Pa-s-m²)).
5. Drop Dart, ASTM D 1709: 2900 g.
6. Tensile Strength, 3 Inches, ASTM D 882: 220 lb/1,220psi (980 N/8,270 kPa).
7. Puncture Strength, ASTM D 4833: 102 lb (454 N).
8. Classification, ASTM E 1745: Class A.
9. Usable Temperature Range: -25 to 170 degrees F (-32 to 77 degrees C).

2.3 ACCESSORIES

- A. General: Ensure accessories are from same manufacturer as reinforced vapor retarders.
- B. Mastic Tape: Griffolyn Fab Tape.
1. Description: Black, double-sided, asphaltic, pressure-sensitive, mastic tape.
 2. Weight: 3.75 pounds per 100 feet.
 3. Thickness: 35 mils.
 4. 3 Inch Seam Shear: 35 pounds.
- C. Self-Adhesive Repair Tape: Griffolyn Griff-Tape.
- D. Pipe Boots: Griffolyn pipe boots, factory-fabricated.

PART 3 EXECUTION

3.1 EXAMINATION

- A. Examine areas to receive reinforced vapor retarders. Notify Architect if areas are not acceptable. Do not begin installation until unacceptable conditions have been corrected.

3.2 INSTALLATION

- A. Install reinforced vapor retarders in accordance with ASTM E 1643 and manufacturer's instructions.
- B. Install vapor retarders continuously at locations under slab as indicated on the drawings. Ensure there are no discontinuities in vapor retarder at seams and penetrations.
- C. Install vapor retarders in largest practical widths.
- D. Ensure subgrade beneath vapor retarder is smooth, level, and compacted with no sharp projections.
- E. Join sections of vapor retarder and seal penetrations in vapor retarder with mastic tape. Ensure vapor retarder surfaces to receive mastic tape are clean and dry.
- F. Ensure there is no moisture entrapment by vapor retarder due to rainfall or ground water intrusion.
- G. Immediately repair holes in vapor retarder with self-adhesive repair tape.
- H. Seal around pipes and other penetrations in vapor retarder with pipe boots in accordance with manufacturer's instructions.

3.3 PROTECTION

- A. Protect reinforced vapor retarders from damage during installation of reinforcing steel and utilities and during placement of concrete slab or granular materials.
- B. Immediately repair damaged vapor retarder in accordance with manufacturer's instructions.

END OF SECTION

Reef Industries, Inc.
9209 Alameda Genoa Rd
Houston, Texas 77075
Toll Free (800) 231-6074
Phone (713) 507-4251
Fax (713) 507-4295
Web Site www.reefindustries.com
E-Mail ri@reefindustries.com

Product Guide Specification

Specifier Notes: This product guide specification is written according to the Construction Specifications Institute (CSI) Format, including *MasterFormat* (1995 Edition), *SectionFormat*, and *PageFormat*, contained in the *CSI Manual of Practice*.

The section must be carefully reviewed and edited by the Architect to meet the requirements of the project and local building code. Coordinate this section with other specification sections and the drawings.

Delete all "Specifier Notes" when editing this section.

SECTION 07260

REINFORCED VAPOR RETARDERS FOR ROOF DECKS

Specifier Notes: This section covers Reef Industries, Inc. "Griffolyn" reinforced vapor retarders for roof deck applications.

To prepare a "Short Form" version of this section, delete Articles 1.2 Related Sections, 1.3 References, and 1.5 Quality Assurance. Renumber remaining articles in Part 1.

Consult Reef Industries for assistance in editing this section for the specific application.

PART 1 GENERAL

1.1 SECTION INCLUDES

- A. Reinforced vapor retarders for roof deck applications.

1.2 RELATED SECTIONS

Specifier Notes: Edit the following list as required for the project. List other sections with work directly related to the reinforced vapor retarders.

- A. Section 07220 - Roof and Deck Insulation.
- B. Section 07410 - Metal Roof and Wall Panels.

- C. Section 07420 - Plastic Roof and Wall Panels.
- D. Section 07500 - Membrane Roofing.
- E. Section 07610 - Sheet Metal Roofing.

1.3 REFERENCES

Specifier Notes: List standards referenced in this section, complete with designations and titles. This article does not require compliance with standards, but is merely a listing of those used.

- A. ASTM D 882 - Tensile Properties of Thin Plastic Sheeting.
- B. ASTM D 1709 - Impact Resistance of Plastic Film by the Free-Falling Dart Method.
- C. ASTM D 2582 - Puncture-Propagation Tear Resistance of Plastic Film and Thin Sheeting.
- D. ASTM D 3776 - Mass per Unit Area (Weight) of Woven Fabric.
- E. ASTM D 4833 - Index Puncture Resistance of Geotextiles, Geomembranes, and Related Products.
- F. ASTM E 84 - Surface Burning Characteristics of Building Materials.
- G. ASTM E 96 - Water Vapor Transmission of Materials.
- H. NFPA 701 - Fire Tests for Flame-Resistant Textiles and Films.

1.4 SUBMITTALS

- A. Comply with Section 01330 - Submittal Procedures.
- B. Product Data: Submit manufacturer's product data, including installation instructions.
- C. Samples: Submit manufacturer's samples of reinforced vapor retarders.

1.5 QUALITY ASSURANCE

Specifier Notes: Describe requirements for a meeting to coordinate the installation of the reinforced vapor retarders and to sequence related work. Delete this paragraph if not required.

- A. Preinstallation Meeting: Convene a preinstallation meeting [2] [_____] weeks before start of installation of reinforced vapor retarders. Require attendance of parties directly affecting work of this section, including Contractor, Architect, and installer. Review installation, protection, and coordination with other work.

1.6 DELIVERY, STORAGE, AND HANDLING

- A. Delivery: Deliver materials to site in manufacturer's original, unopened containers and packaging, with labels clearly identifying product name and manufacturer.
- B. Storage: Store materials in a clean, dry area in accordance with manufacturer's instructions.

- C. Handling: Protect materials during handling and installation to prevent damage.

PART 2 PRODUCTS

2.1 MANUFACTURER

- A. Reef Industries, Inc., 9209 Almeda Genoa Rd., Houston, Texas 77075.
Toll Free (800) 231-6074. Phone (713) 507-4251. Fax (713) 507-4295.
Web Site www.reefindustries.com. E-Mail ri@reefindustries.com.

2.2 REINFORCED VAPOR RETARDERS FOR ROOF DECKS

Specifier Notes: Consult Reef Industries for assistance in determining the required reinforced vapor retarder for the specific roof deck application. Delete vapor retarders not required.

- A. Reinforced Vapor Retarder: Griffolyn Type-65.
 - 1. Material: 3-ply laminate, combining 2 layers of high-density polyethylene and 1 high-strength non-woven cord grid.
 - 2. Weight, ASTM D 3776: 37 lb/1,000 ft² (18.1 kg/100 m²).
 - 3. Puncture Propagation Tear, ASTM D 2582: 28 lb (124 N).
 - 4. Permeance (Perm), ASTM E 96: 0.038 grains/hr-ft²-in Hg (2.18 ng/(Pa-s-m²)).
 - 5. Drop Dart, ASTM D 1709: 500 g.
 - 6. Tensile Strength, 3 Inches, ASTM D 882: 96 lb/5,442 psi (427 N/37,522 kPa).
 - 7. Puncture Strength, ASTM D 4833: 24 lb (107 N).
 - 8. Usable Temperature Range: -25 to 170 degrees F (-32 to 77 degrees C).

- B. Reinforced Vapor Retarder: Griffolyn Type-85.
 - 1. Material: 5-ply laminate, combining 3 layers of high-density polyethylene and 2 high-strength non-woven cord grids.
 - 2. Weight, ASTM D 3776: 70 lb/1,000 ft² (34.2 kg/100 m²).
 - 3. Puncture Propagation Tear, ASTM D 2582: 40 lb (178 N).
 - 4. Permeance (Perm), ASTM E 96: 0.027 grains/hr-ft²-in Hg (1.551 ng/(Pa-s-m²)).
 - 5. Drop Dart, ASTM D 1709: 1,900 g.
 - 6. Tensile Strength, 3 Inches, ASTM D 882: 225 lb/3,846 psi (1000 N/26,515 kPa).
 - 7. Puncture Strength, ASTM D 4833: 50 lb (222 N).
 - 8. Usable Temperature Range: -40 to 170 degrees F (-40 to 77 degrees C).

- C. Reinforced Vapor Retarder: Griffolyn Type-105.
 - 1. Material: 7-ply laminate, combining 4 layers of high-density polyethylene and 3 high-strength non-woven cord grids.
 - 2. Weight, ASTM D 3776: 82 lb/1,000 ft² (40 kg/100 m²).
 - 3. Puncture Propagation Tear, ASTM D 2582: 45 lb (200 N).
 - 4. Permeance (Perm), ASTM E 96: 0.021 grains/hr-ft²-in Hg (1.207 ng/(Pa-s-m²)).
 - 5. Drop Dart, ASTM D 1709: 2,300 g.
 - 6. Tensile Strength, 3 Inches, ASTM D 882: 275 lb/5,464 psi (1,223 N/37,674 kPa).
 - 7. Puncture Strength, ASTM D 4833: 72 lb (320 N).
 - 8. Usable Temperature Range: -45 to 170 degrees F (-42 to 77 degrees C).

- D. Reinforced Vapor Retarder: Griffolyn Vaporguard.
 - 1. Material: 3-ply laminate, with an aluminum core surrounded by 2 layers of multi-axially oriented, high-density polyethylene.

2. Weight, ASTM D 3776: 70 lb/1,000 ft² (34.2 kg/100 m²).
 3. Puncture Propagation Tear, ASTM D 2582: 15 lb (68 N).
 4. Permeance (Perm), ASTM E 96: 0.000 grains/hr-ft²-in Hg (0.000 ng/(Pa-s-m²)).
 5. Drop Dart, ASTM D 1709: 590 g.
 6. Tensile Strength, 3 Inches, ASTM D 882: 100 lb/2,200 psi (448 N/15,160 kPa).
 7. Puncture Strength, ASTM D 4833: 42 lb (187 N).
 8. Usable Temperature Range: -40 to 170 degrees F (-40 to 77 degrees C).
- E. Fire Retardant Reinforced Vapor Retarder: Griffolyn Type-55 FR.
1. Material: Fire retardant 3-ply laminate, combining 2 layers of linear low-density polyethylene and 1 high-strength non-woven cord grid.
 2. Weight, ASTM D 3776: 29 lb/1,000 ft² (14 kg/100 m²).
 3. Puncture Propagation Tear, ASTM D 2582: 18 lb (80 N).
 4. Permeance (Perm), ASTM E 96: 0.062 grains/hr-ft²-in Hg (3.556 ng/(Pa-s-m²)).
 5. Drop Dart, ASTM D 1709: 330 g.
 6. Tensile Strength, 3 Inches, ASTM D 882: 85 lb/5,059 psi (378 N/34,885 kPa).
 7. Puncture Strength, ASTM D 4833: 23 lb (102 N).
 8. Surface Burning Characteristics:
 - a. NFPA 701, Large Scale: Pass.
 - b. UBC 42 and ASTM E 84: Class I, Class A flame spread rating. Flame spread 5, smoke developed 45.
 9. Usable Temperature Range: -5 to 150 degrees F (-20 to 66 degrees C).
- F. Fire Retardant Reinforced Vapor Retarder: Griffolyn TX-1200 FR.
1. Material: Fire retardant 3-ply laminate, combining 2 layers of linear low-density polyethylene and 1 high-strength non-woven cord grid.
 2. Weight, ASTM D 3776: 43 lb/1,000 ft² (21 kg/100 m²).
 3. Puncture Propagation Tear, ASTM D 2582: 26 lb (116 N).
 4. Permeance (Perm), ASTM E 96: 0.036 grains/hr-ft²-in Hg (2.06 ng/(Pa-s-m²)).
 5. Drop Dart, ASTM D 1709 Method B: 330 g.
 6. Tensile Strength, 3 Inches, ASTM D 882: 100 lb/4,504 psi (445 N/31,058 kPa).
 7. Puncture Strength, ASTM D 4833: 26 lb (116 N).
 8. Surface Burning Characteristics:
 - a. NFPA 701, Large Scale: Pass.
 - b. UBC 42 and ASTM E 84: Class I, Class A flame spread rating. Flame spread 5, smoke developed 70.
 9. Usable Temperature Range: -10 to 170 degrees F (-23 to 77 degrees C).
- G. Fire Retardant Reinforced Vapor Retarder: Griffolyn Type-90 FR.
1. Material: Fire retardant 5-ply laminate, combining 3 layers of linear low-density polyethylene and 2 high-strength non-woven cord grids.
 2. Weight, ASTM D 3776: 70 lb/1,000 ft² (34.2 kg/100 m²).
 3. Puncture Propagation Tear, ASTM D 2582: 36 lb (1608 N).
 4. Permeance (Perm), ASTM E 96: 0.028 grains/hr-ft²-in Hg (1.61 ng/(Pa-s-m²)).
 5. Drop Dart, ASTM D 1709: 1,200 g.
 6. Tensile Strength, 3 Inches, ASTM D 882: 185 lb/4,250 psi (823 N/29,200 kPa).
 7. Puncture Strength, ASTM D 4833: 47 lb (209 N).
 8. Surface Burning Characteristics:
 - a. NFPA 701, Large Scale: Pass.
 - b. UBC 42 and ASTM E 84: Class I, Class B flame spread rating. Flame spread 5, smoke developed 135.
 9. Usable Temperature Range: -40 to 170 degrees F (-40 to 77 degrees C).

2.3 ACCESSORIES

- A. General: Ensure accessories are from same manufacturer as reinforced vapor retarders.
- B. Mastic Tape: Griffolyn Fab Tape.
 - 1. Description: Black, double-sided, asphaltic, pressure-sensitive, mastic tape.
 - 2. Weight: 3.75 pounds per 100 feet.
 - 3. Thickness: 35 mils.
 - 4. 3 Inch Seam Shear: 35 pounds.
- C. Self-Adhesive Repair Tape: Griffolyn Griff-Tape.
- D. Pipe Boots: Griffolyn pipe boots, factory-fabricated.

PART 3 EXECUTION

3.1 EXAMINATION

- A. Examine areas to receive reinforced vapor retarders. Notify Architect if areas are not acceptable. Do not begin installation until unacceptable conditions have been corrected.

3.2 INSTALLATION

- A. Install reinforced vapor retarders in accordance with manufacturer's instructions.
- B. Install vapor retarders continuously at locations on roof deck as indicated on the drawings. Ensure there are no discontinuities in vapor retarder at seams and penetrations.
- C. Install vapor retarders in largest practical widths.
- D. Ensure surface beneath vapor retarder is smooth with no sharp projections.
- E. Join sections of vapor retarder and seal penetrations in vapor retarder with mastic tape. Ensure vapor retarder surfaces to receive mastic tape are clean and dry.
- F. Immediately repair holes in vapor retarder with self-adhesive repair tape.
- G. Seal around pipes and other penetrations in vapor retarder with pipe boots in accordance with manufacturer's instructions.

3.3 PROTECTION

- A. Protect reinforced vapor retarders from damage until covered by roof insulation.
- B. Immediately repair damaged vapor retarder in accordance with manufacturer's instructions.

END OF SECTION

Reef Industries, Inc.
9209 Almeda Genoa Rd.
Houston, Texas 77075
Toll Free (800) 231-6074
Phone (713) 507-4251
Fax (713) 507-4295
Web Site www.reefindustries.com
E-Mail ri@reefindustries.com

Product Guide Specification

Specifier Notes: This product guide specification is written according to the Construction Specifications Institute (CSI) Format, including *MasterFormat* (1995 Edition), *SectionFormat*, and *PageFormat*, contained in the *CSI Manual of Practice*.

The section must be carefully reviewed and edited by the Architect to meet the requirements of the project and local building code. Coordinate this section with other specification sections and the drawings.

Delete all "Specifier Notes" when editing this section.

SECTION 07260

REINFORCED VAPOR RETARDERS FOR WALLS

Specifier Notes: This section covers Reef Industries, Inc. "Griffolyn" reinforced vapor retarders for wall applications.

To prepare a "Short Form" version of this section, delete Articles 1.2 Related Sections, 1.3 References, and 1.5 Quality Assurance. Renumber remaining articles in Part 1.

Consult Reef Industries for assistance in editing this section for the specific application.

PART 1 GENERAL

1.1 SECTION INCLUDES

- A. Reinforced vapor retarders for wall applications.

1.2 RELATED SECTIONS

Specifier Notes: Edit the following list as required for the project. List other sections with work directly related to the reinforced vapor retarders.

- A. Section 07410 - Metal Roof and Wall Panels.
- B. Section 07420 - Plastic Roof and Wall Panels.

- C. Section 07460 - Siding.
- D. Section 09250 - Gypsum Board.
- E. Section 09500 - Ceilings.
- F. Section 09720 - Wall Covering.

1.3 REFERENCES

Specifier Notes: List standards referenced in this section, complete with designations and titles. This article does not require compliance with standards, but is merely a listing of those used.

- A. ASTM D 882 - Tensile Properties of Thin Plastic Sheeting.
- B. ASTM D 1709 - Impact Resistance of Plastic Film by the Free-Falling Dart Method.
- C. ASTM D 2582 - Puncture-Propagation Tear Resistance of Plastic Film and Thin Sheeting.
- D. ASTM D 3776 - Mass per Unit Area (Weight) of Woven Fabric.
- E. ASTM D 4833 - Index Puncture Resistance of Geotextiles, Geomembranes, and Related Products.
- F. ASTM E 84 - Surface Burning Characteristics of Building Materials.
- G. ASTM E 96 - Water Vapor Transmission of Materials.
- H. NFPA 701 - Fire Tests for Flame-Resistant Textiles and Films.

1.4 SUBMITTALS

- A. Comply with Section 01330 - Submittal Procedures.
- B. Product Data: Submit manufacturer's product data, including installation instructions.
- C. Samples: Submit manufacturer's samples of reinforced vapor retarders.

1.5 QUALITY ASSURANCE

Specifier Notes: Describe requirements for a meeting to coordinate the installation of the reinforced vapor retarders and to sequence related work. Delete this paragraph if not required.

- A. Preinstallation Meeting: Convene a preinstallation meeting [2] [_____] weeks before start of installation of reinforced vapor retarders. Require attendance of parties directly affecting work of this section, including Contractor, Architect, and installer. Review installation, protection, and coordination with other work.

1.6 DELIVERY, STORAGE, AND HANDLING

- A. Delivery: Deliver materials to site in manufacturer's original, unopened containers and

packaging, with labels clearly identifying product name and manufacturer.

- B. Storage: Store materials in a clean, dry area in accordance with manufacturer's instructions.
- C. Handling: Protect materials during handling and installation to prevent damage.

PART 2 PRODUCTS

2.1 MANUFACTURER

- A. Reef Industries, Inc., 9209 Almeda Genoa Rd., Houston, Texas 77075.
Toll Free (800) 231-6074. Phone (713) 507-4251. Fax (713) 507-4295.
Web Site www.reefindustries.com. E-Mail ri@reefindustries.com.

2.2 REINFORCED VAPOR RETARDERS FOR WALLS

Specifier Notes: Consult Reef Industries for assistance in determining the required reinforced vapor retarder for the specific wall application. Delete vapor retarders not required.

- A. Reinforced Vapor Retarder: Griffolyn Type-65.
 - 1. Material: 3-ply laminate, combining 2 layers of high-density polyethylene and 1 high-strength non-woven cord grid.
 - 2. Weight, ASTM D 3776: 37 lb/1,000 ft² (18.1 kg/100 m²).
 - 3. Puncture Propagation Tear, ASTM D 2582: 28 lb (124 N).
 - 4. Permeance (Perm), ASTM E 96: 0.038 grains/hr-ft²-in Hg (2.18 ng/(Pa-s-m²)).
 - 5. Drop Dart, ASTM D 1709: 500 g.
 - 6. Tensile Strength, 3 Inches, ASTM D 882: 96 lb/5,442 psi (427 N/37,522 kPa).
 - 7. Puncture Strength, ASTM D 4833: 24 lb (106 N).
 - 8. Usable Temperature Range: -25 to 170 degrees F (-32 to 77 degrees C).

- B. Reinforced Vapor Retarder: Griffolyn Type-85.
 - 1. Material: 5-ply laminate, combining 3 layers of high-density polyethylene and 2 high-strength non-woven cord grids.
 - 2. Weight, ASTM D 3776: 70 lb/1,000 ft² (34.2 kg/100 m²).
 - 3. Puncture Propagation Tear, ASTM D 2582: 40 lb (178 N).
 - 4. Permeance (Perm), ASTM E 96: 0.027 grains/hr-ft²-in Hg (1.551 ng/(Pa-s-m²)).
 - 5. Drop Dart, ASTM D 1709: 1,900 g.
 - 6. Tensile Strength, 3 Inches, ASTM D 882: 225 lb/3,846 psi (1000 N/26,515 kPa).
 - 7. Puncture Strength, ASTM D 4833: 50 lb (222 N).
 - 8. Usable Temperature Range: -40 to 170 degrees F (-40 to 77 degrees C).

- C. Reinforced Vapor Retarder: Griffolyn Type-105.
 - 1. Material: 7-ply laminate, combining 4 layers of high-density polyethylene and 3 high-strength non-woven cord grids.
 - 2. Weight, ASTM D 3776: 82lb/1,000 ft² (40 kg/100 m²).
 - 3. Puncture Propagation Tear, ASTM D 2582: 45 lb (200 N).
 - 4. Permeance (Perm), ASTM E 96: 0.021 grains/hr-ft²-in Hg (1.207 ng/(Pa-s-m²)).
 - 5. Drop Dart, ASTM D 1709: 2,300 g.
 - 6. Tensile Strength, 3 Inches, ASTM D 882: 275 lb/5,464 psi (1,223 N/37,674 kPa).
 - 7. Puncture Strength, ASTM D 4833: 72 lb (320 N).
 - 8. Usable Temperature Range: -45 to 170 degrees F (-42 to 77 degrees C).

- D. Reinforced Vapor Retarder: Griffolyn Vaporguard.
1. Material: 3-ply laminate, with an aluminum core surrounded by 2 layers of multi-axially oriented, high-density polyethylene.
 2. Weight, ASTM D 3776: 70 lb/1,000 ft² (34.2 kg/100 m²).
 3. Puncture Propagation Tear, ASTM D 2582: 15 lb (68 N).
 4. Permeance (Perm), ASTM E 96: 0.000 grains/hr-ft²-in Hg (0.000 ng/(Pa-s-m²)).
 5. Drop Dart, ASTM D 1709: 590 g.
 6. Tensile Strength, 3 Inches, ASTM D 882: 100 lb/2,200 psi (448 N/15,160 kPa).
 7. Puncture Strength, ASTM D 4833: 42 lb (187 N).
 8. Usable Temperature Range: -40 to 170 degrees F (-40 to 77 degrees C).
- E. Fire Retardant Reinforced Vapor Retarder: Griffolyn Type-55 FR.
1. Material: Fire retardant 3-ply laminate, combining 2 layers of linear low-density polyethylene and 1 high-strength non-woven cord grid.
 2. Weight, ASTM D 3776: 29 lb/1,000 ft² (14 kg/100 m²).
 3. Puncture Propagation Tear, ASTM D 2582: 18 lb (80 N).
 4. Permeance (Perm), ASTM E 96: 0.062 grains/hr-ft²-in Hg (3.556 ng/(Pa-s-m²)).
 5. Drop Dart, ASTM D 1709: 330 g.
 6. Tensile Strength, 3 Inches, ASTM D 882: 85 lb/5,059 psi (378 N/34,885 kPa).
 7. Puncture Strength, ASTM D 4833: 23 lb (102 N).
 8. Surface Burning Characteristics:
 - a. NFPA 701, Large Scale: Pass.
 - b. UBC 42 and ASTM E 84: Class I, Class A flame spread rating. Flame spread 5, smoke developed 45.
 9. Usable Temperature Range: -5 to 150 degrees F (-20 to 66 degrees C).
- F. Fire Retardant Reinforced Vapor Retarder: Griffolyn TX-1200 FR.
1. Material: Fire retardant 3-ply laminate, combining 2 layers of linear low-density polyethylene and 1 high-strength non-woven cord grid.
 2. Weight, ASTM D 3776: 43 lb/1,000 ft² (21 kg/100 m²).
 3. Puncture Propagation Tear, ASTM D 2582: 26 lb (116 N).
 4. Permeance (Perm), ASTM E 96: 0.036 grains/hr-ft²-in Hg (2.06 ng/(Pa-s-m²)).
 5. Drop Dart, ASTM D 1709 Method B: 330 g.
 6. Tensile Strength, 3 Inches, ASTM D 882: 100 lb/4,504 psi (445 N/31,058 kPa).
 7. Puncture Strength, ASTM D 4833: 26 lb (116 N).
 8. Surface Burning Characteristics:
 - a. NFPA 701, Large Scale: Pass.
 - b. UBC 42 and ASTM E 84: Class I, Class A flame spread rating. Flame spread 5 smoke developed 70.
 9. Usable Temperature Range: -10 to 170 degrees F (-23 to 77 degrees C).
- G. Fire Retardant Reinforced Vapor Retarder: Griffolyn Type-90 FR.
1. Material: Fire retardant 5-ply laminate, combining 3 layers of linear low-density polyethylene and 2 high-strength non-woven cord grids.
 2. Weight, ASTM D 3776: 70 lb/1,000 ft² (34.2 kg/100 m²).
 3. Puncture Propagation Tear, ASTM D 2582: 36 lb (160 N).
 4. Permeance (Perm), ASTM E 96: 0.028 grains/hr-ft²-in Hg (1.61 ng/(Pa-s-m²)).
 5. Drop Dart, ASTM D 1709: 1,200 g.
 6. Tensile Strength, 3 Inches, ASTM D 882: 185 lb/4,250 psi (823N/29,200 kPa).
 7. Puncture Strength, ASTM D 4833: 47 lb (209 N).
 8. Surface Burning Characteristics:

- a. NFPA 701, Large Scale: Pass.
 - b. UBC 42 and ASTM E 84: Class 1, Class B flame spread rating. Flame spread 5, smoke developed 135.
9. Usable Temperature Range: -40 to 170 degrees F (-40 to 77 degrees C).

2.3 ACCESSORIES

- A. General: Ensure accessories are from same manufacturer as reinforced vapor retarders.
- B. Mastic Tape: Griffolyn Fab Tape.
1. Description: Black, double-sided, asphaltic, pressure-sensitive, mastic tape.
 2. Weight: 3.75 pounds per 100 feet.
 3. Thickness: 35 mils.
 4. 3 Inch Seam Shear: 35 pounds.
- C. Self-Adhesive Repair Tape: Griffolyn Griff-Tape.
- D. Pipe Boots: Griffolyn pipe boots, factory-fabricated.

PART 3 EXECUTION

3.1 EXAMINATION

- A. Examine areas to receive reinforced vapor retarders. Notify Architect if areas are not acceptable. Do not begin installation until unacceptable conditions have been corrected.

3.2 INSTALLATION

- A. Install reinforced vapor retarders in accordance with manufacturer's instructions.
- B. Install vapor retarders continuously at locations on walls as indicated on the drawings. Ensure there are no discontinuities in vapor retarder at seams and penetrations.
- C. Install vapor retarders in largest practical widths.
- D. Ensure surface behind vapor retarder is smooth with no sharp projections.
- E. Join sections of vapor retarder and seal penetrations in vapor retarder with mastic tape. Ensure vapor retarder surfaces to receive mastic tape are clean and dry.
- F. Immediately repair holes in vapor retarder with self-adhesive repair tape.
- G. Seal around pipes and other penetrations in vapor retarder with pipe boots in accordance with manufacturer's instructions.

3.3 PROTECTION

- A. Protect reinforced vapor retarders from damage until covered by finish wall.
- B. Immediately repair damaged vapor retarder in accordance with manufacturer's instructions.

END OF SECTION

Installation Instructions Griffolyn UnderSlab Vapor Retarders

Note: These installation instructions need to be read completely before beginning any installation of the Griffolyn System to ensure effective/proper methods of installation are used. The Griffolyn system includes Griffolyn vapor retarder material, Fab Tape, (an asphaltic mastic), and pipeboots. (Installation instructions for Griffolyn Type 65G and R30G are covered in a separate sheet.)

1. Prior to the placement of the reinforcing steel and the pouring of concrete, ensure the sub-grade beneath the vapor retarder is smooth, level and compacted. The Griffolyn vapor retarders can be installed over sand, smooth aggregate or a tamped earth base. If a Griffolyn vapor retarder is to be placed over coarse granular fill, a thin layer of approximately 1" of fine graded material should be rolled or compacted over the fill prior to installing the vapor retarder.
2. Install Griffolyn continuously at locations under slab as indicated on the drawings. Ensure there are no discontinuities in the Griffolyn at seams and penetrations. Griffolyn is rolled out in the widest practical widths (minimum 20' wide) parallel to the direction of the concrete pour, totally covering the future slab site. Allow sufficient material along perimeter walls to cover wall areas up to top of slab elevations.
3. All joints/seams shall be overlapped six inches. To seal the joint/overlapped area, fold the Griffolyn top section back and apply the Fab Tape 4 inches (100 mm) back and parallel to the edge of the bottom section (See drawing.) Smooth out any folds or wrinkles in the vapor retarder while applying the tape. Remove the release paper starting at one end of the taped section and firmly press the top section to the bottom while maintaining even tension to avoid gaps, which could cause leaks. Allow adequate time for complete bonding before subjecting the seam to substantial stress.
4. Seal around pipes and other penetrations in the vapor retarder using Griffolyn Pipe Boots. Attach Fab Tape around the bottom perimeter of the pipe boot flange ensuring the ends of the tape overlap slightly. Remove one section of the release paper. Lower the boot over the penetration and press the exposed tape firmly to the vapor retarder material. Remove the remaining release paper and secure the remainder of the flange.

Lower the tube section of the pipe boot and wrap the Fab Tape around the pipe. Place the tape to allow some slack when the boot is raised above the tape. Remove release paper. Raise the tube section and secure over tape. Secure the pipe boot tube in place with clamp or tie down over the Fab Tape. (See pipe boot installation details)
5. Holes and tears that occur during or after installation must be repaired before concrete slab placement. Cut a rectangular Griffolyn piece 6 -12 inches larger than the area to be repaired. Attach Fab Tape around the perimeter of the patch, ensuring the ends of the Fab Tape overlap. Remove the release paper from the Fab Tape. Firmly press the patch material to the Griffolyn vapor retarder maintaining even tension to avoid gaps.
6. Lap Griffolyn vapor retarder up vertical walls to an elevation equal to the top slab surface and on top of footings. Secure vapor retarder to the wall using two rows of Fab Tape (See Drawing.)

Important: For all joints/seams, pipe boot installations or repairs both Griffolyn surfaces should be clean and dry, free of moisture dirt and dust to ensure optimal bonding and sealing. If the air temperature drops below 40 degrees F (4 degrees C) measures must be taken to ensure the seamed area/tape provides an effective seal.

Critical: All ponded water from rainfall, washing operations, etc, should be removed from on top of the vapor retarder prior to placement of the concrete.

February 2001

THE GRIFFOLYN[®]
DIVISION OF REEF INDUSTRIES, INC.

Call today for
technical assistance
or to place your order.

800/231-6074

9209 Almeda Genoa
Houston, Tx 77075

Tel: 713.507.4251
Fax: 713.507.4295

Detail Architectural Drawings

Fab Tape Seam (DWG & Instruction Sheet)

Concrete Slab on Grade – Grade Beam Detail Fig 1 (DWG)

Concrete Slab on Grade – Grade Beam Detail Fig 2 (DWG)

Concrete Slab on Grade – Grade Beam Detail Fig 3 (DWG)

Concrete Slab on Grade – Grade Beam Detail Fig 4 (DWG)

Griffolyn Repair (DWG)

General Installation Instructions (Sheet)

Pipe Cluster (2 DWGs)

Vapor Retarder Attachments (DWG)

Detail – Vapor Retard (DWG)

Fab Tape Seams

Fab Tape is an asphaltic mastic which creates a durable field seam between multiple sections and for sealing around penetrations in a vapor retarder. Proper installation is imperative to ensure optimal bonding and sealing.

Both Griffolyn surfaces must be clean and dry. On a dirty surface, the tape will adhere to the sand and dust instead of the Griffolyn vapor retarder. If the surface is wet, pockets of moisture are created which can thermally contract and expand sufficiently to degrade adhesion and destroy the seal.

Warm temperatures will promote better initial adhesion. Fab Tape will reach maximum bond strength in about 24 hours in a warm environment. Ambient temperatures of less than 60°F will extend the time required for bonding unless additional heat sources are applied.

Proper grading of the substrate beneath the vapor retarder is essential for optimal sealing. A rough, rutted and/or lumpy subgrade can cause wrinkles and gaps in the seam area which make it difficult to achieve an effective bond.

To begin installation, lay both sheets over a smooth subgrade with a 6" overlap. Fold the top section back and apply the Fab Tape 4" back and parallel to the edge of the bottom section. Smooth out any gaps or voids while applying the tape.

Remove the release paper and firmly press the top section to the bottom while maintaining even tension on the material to avoid gaps which could cause leaks.

Allow adequate time for complete bonding before subjecting the joint to substantial stress.



REEF
INDUSTRIES, INC.

FAB TAPE SEAM

FAB TAPE SEAM RC 4-24.dwg

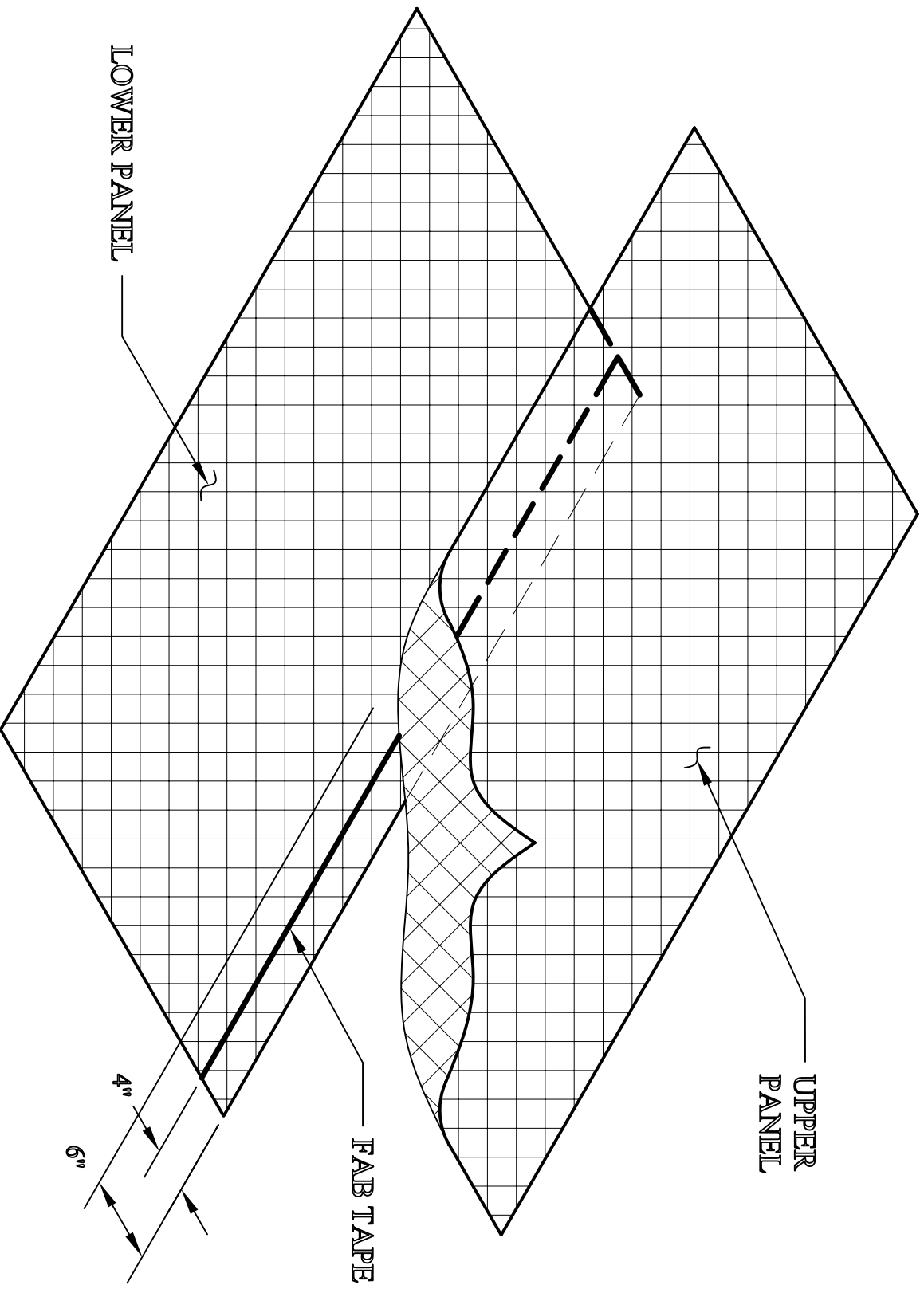

NOTE: This document provides information related to the installation of "FAB TAPE" and related components. This document does not attempt to address all aspects of an installation for all application. The information presented is general information in order to familiarize the individual with the overall scope of the project.



REEF INDUSTRIES, INC.

CONCRETE SLAB ON GRADE: FIG 1

GRADEBEAM DETAIL RC 4-24.dwg

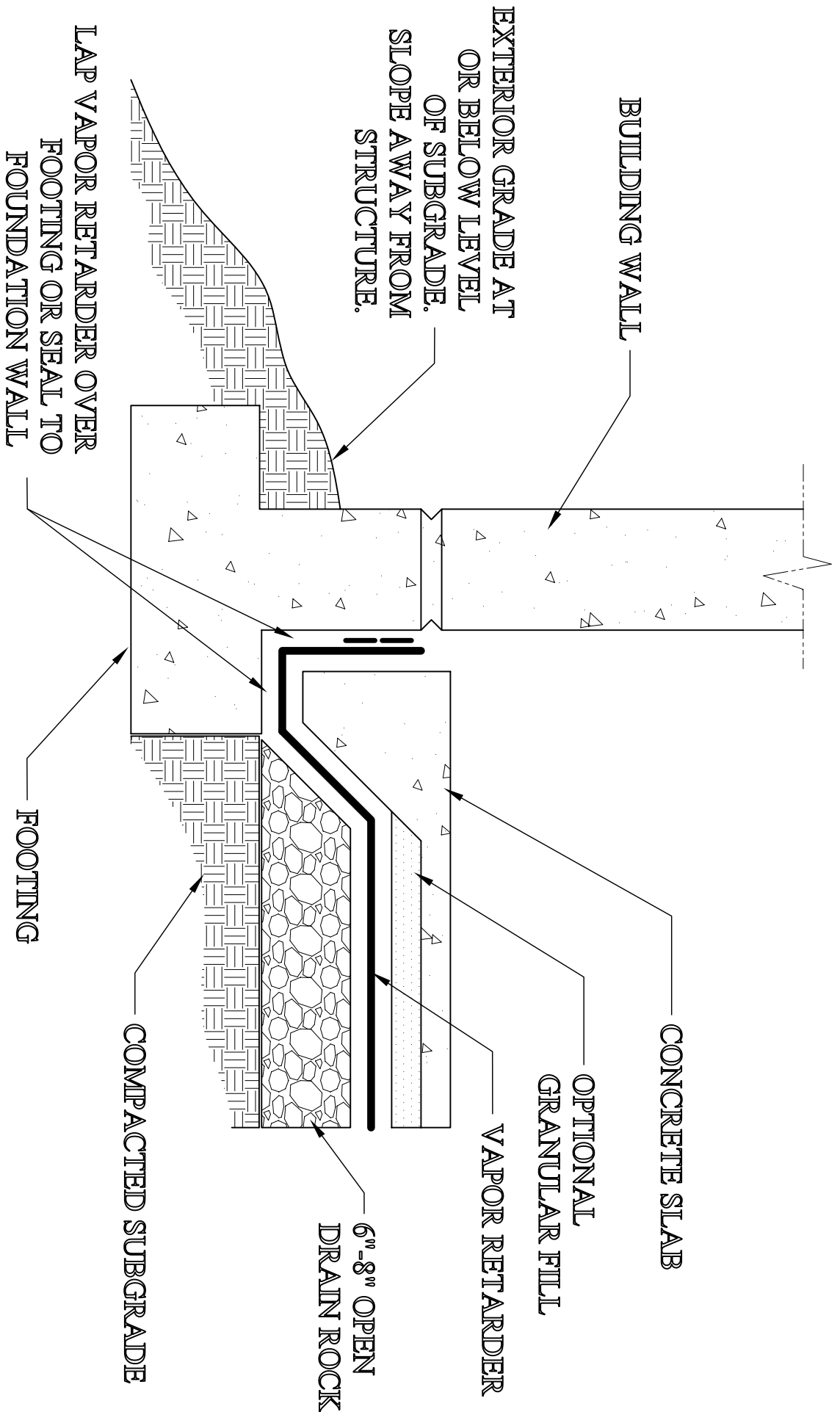

FIG. 1

OPTIMUM RELATIONSHIP OF VAPOR RETARDER COMPONENTS

2001 REEF INDUSTRIES INC. All rights reserved. No part of this document may be reproduced or copied in any form or by any means without written permission from Reef Industries Inc.



REEF INDUSTRIES, INC.

CONCRETE SLAB ON GRADE: FIG 2

GRADEBEAM DETAIL RC 4-24.dwg

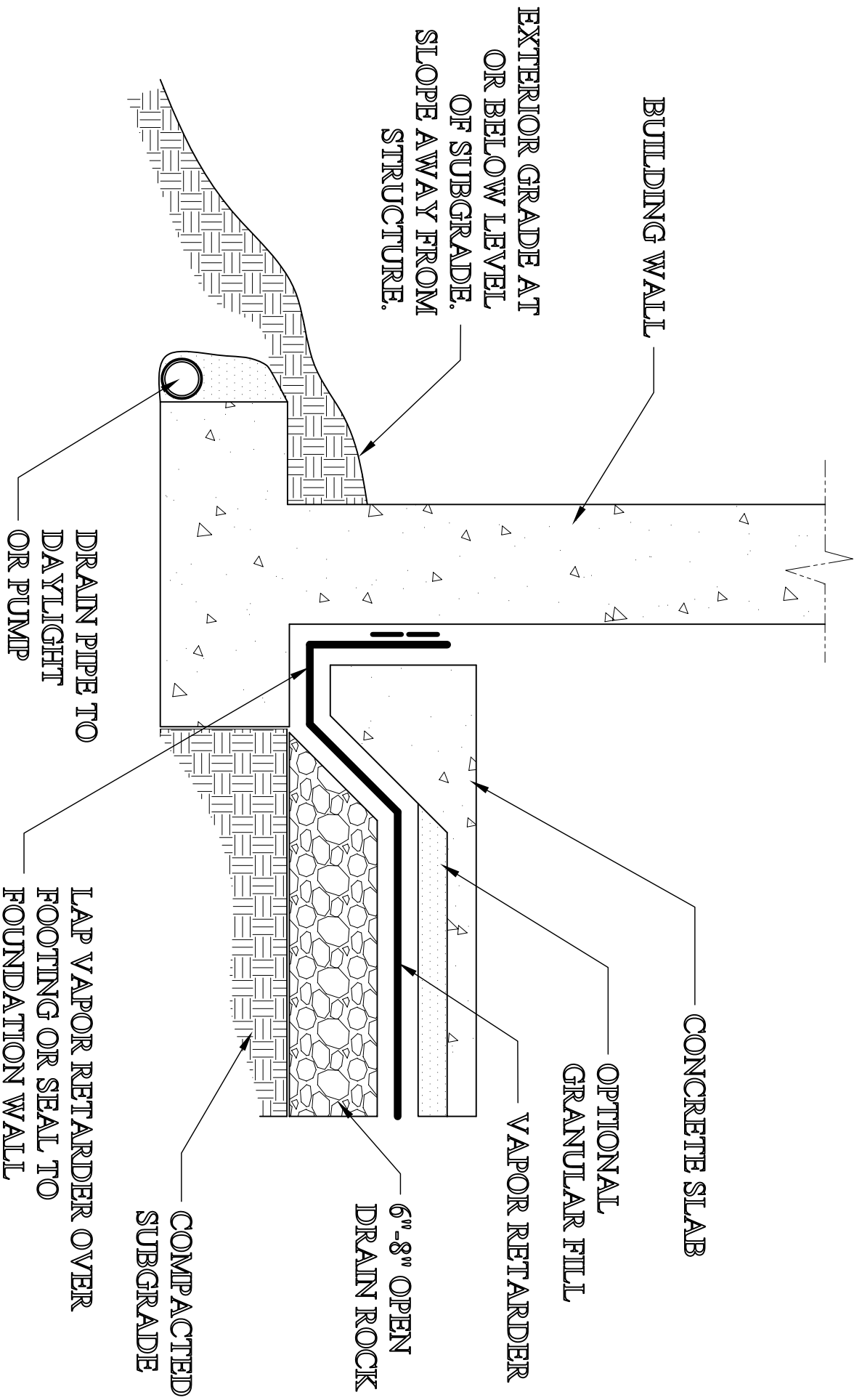

FIG. 2

CONCRETE SLAB ON GRADE: SOLUTION FOR SUBGRADE SLIGHTLY BELOW EXTERIOR GRADE

2001 REEF INDUSTRIES INC. All rights reserved. No part of this document may be reproduced or copied in any form or by any means without written permission from Reef Industries Inc.



REEF INDUSTRIES, INC

CONCRETE SLAB ON GRADE: FIG 3

GRADEBEAM DETAIL RC 4-24.dwg

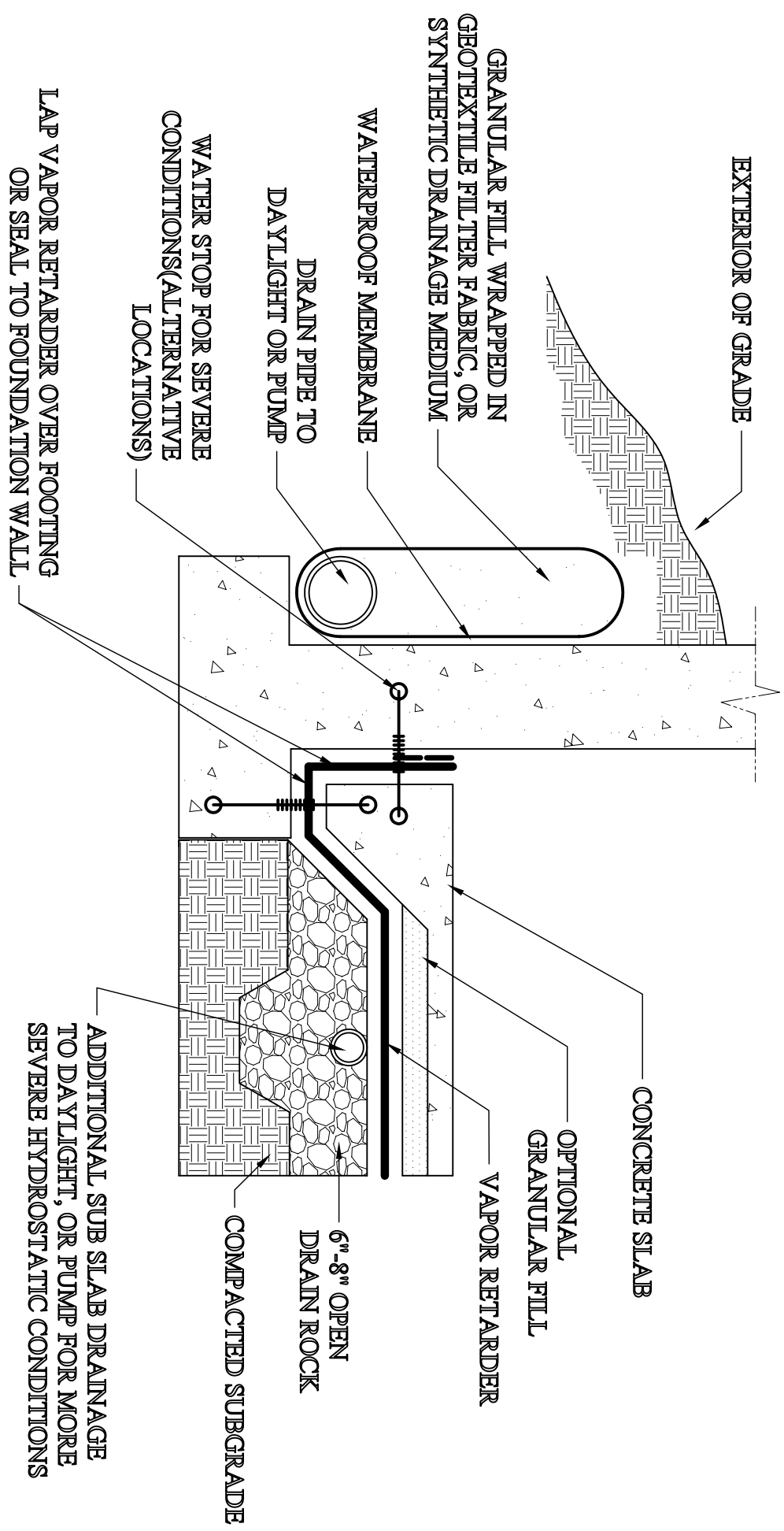

FIG. 3

SOLUTION FOR SUBGRADE UP TO ONE STORY BELOW GRADE WITH NO HYDROSTATIC PRESSURE ON VAPOR RETARDER

2001 REEF INDUSTRIES INC. All rights reserved. No part of this document may be reproduced or copied in any form or by any means without written permission from Reef Industries Inc.



REEF INDUSTRIES, INC.

CONCRETE SLAB ON GRADE: FIG 4

GRADEBEAM DETAIL RC 4-24.dwg

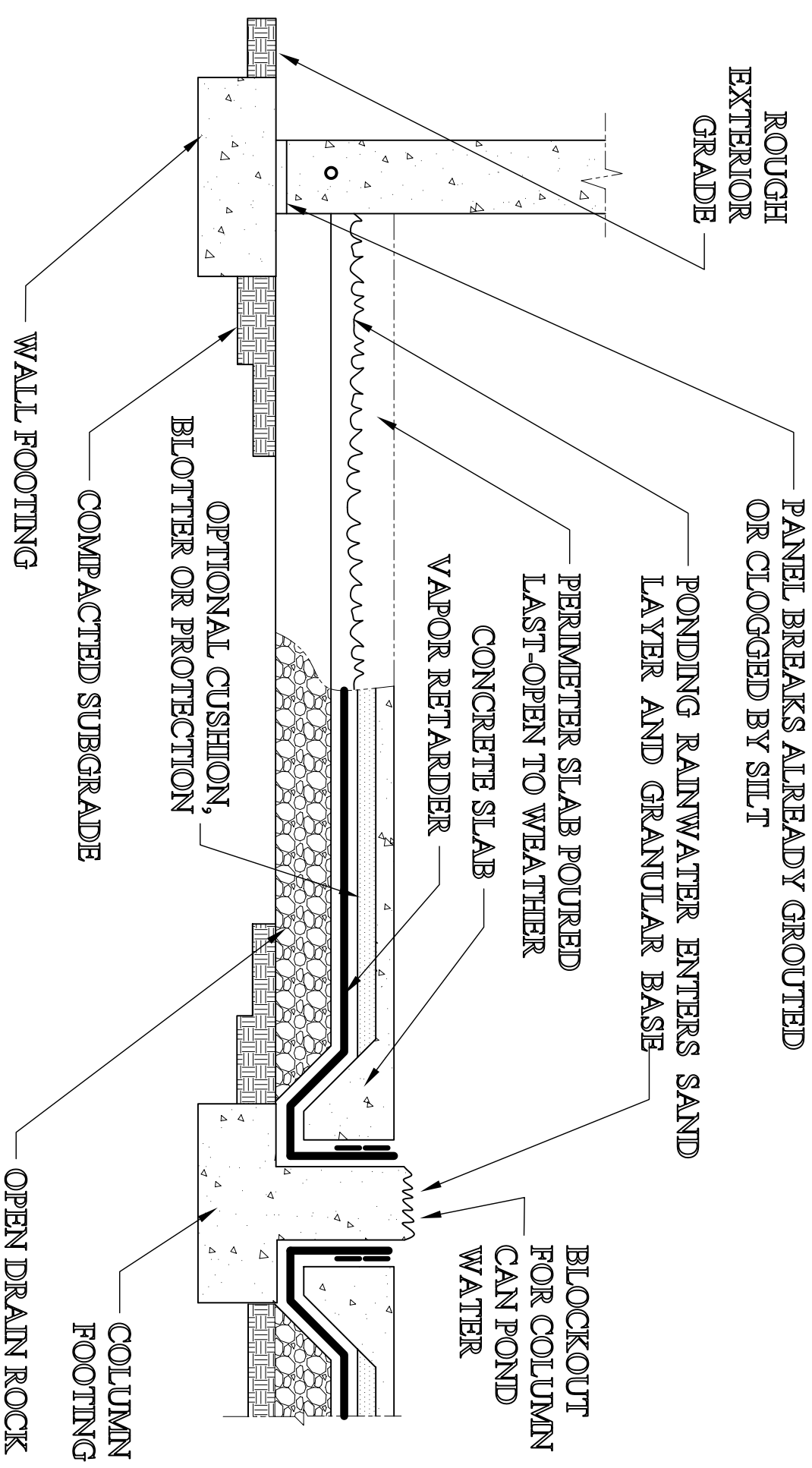

FIG. 4

HOW MOISTURE CAN BE RETAINED IN BASE OR CUSHION, BLOTTER, OR PROTECTION COURSE DURING CONSTRUCTION

2001 REEF INDUSTRIES INC. All rights reserved. No part of this document may be reproduced or copied in any form or by any means without written permission from Reef Industries Inc.



REEF
INDUSTRIES, INC.

GRIFFOLYN REPAIR

GRIFFOLYN REPAIR RC 4-24.dwg

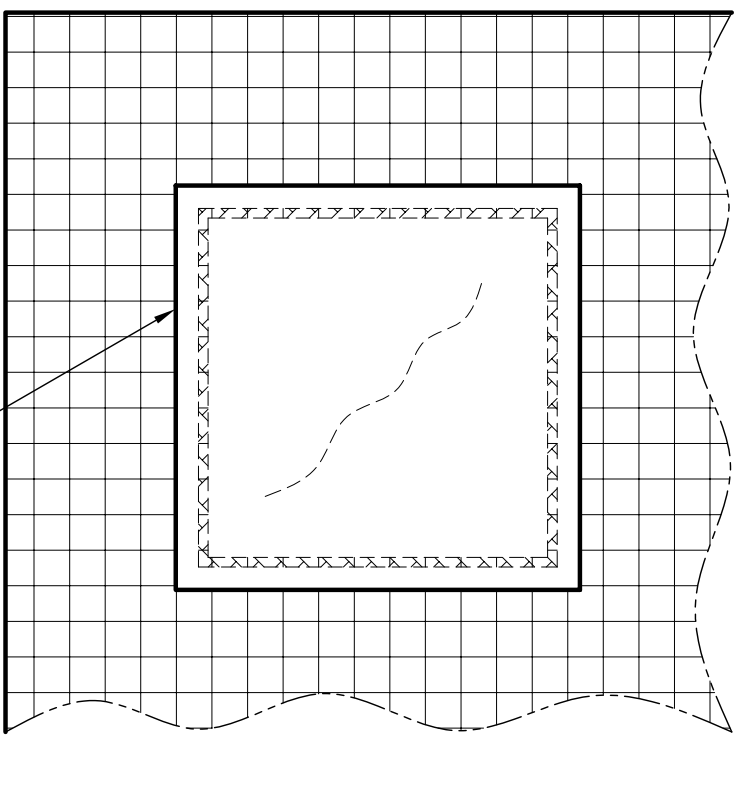
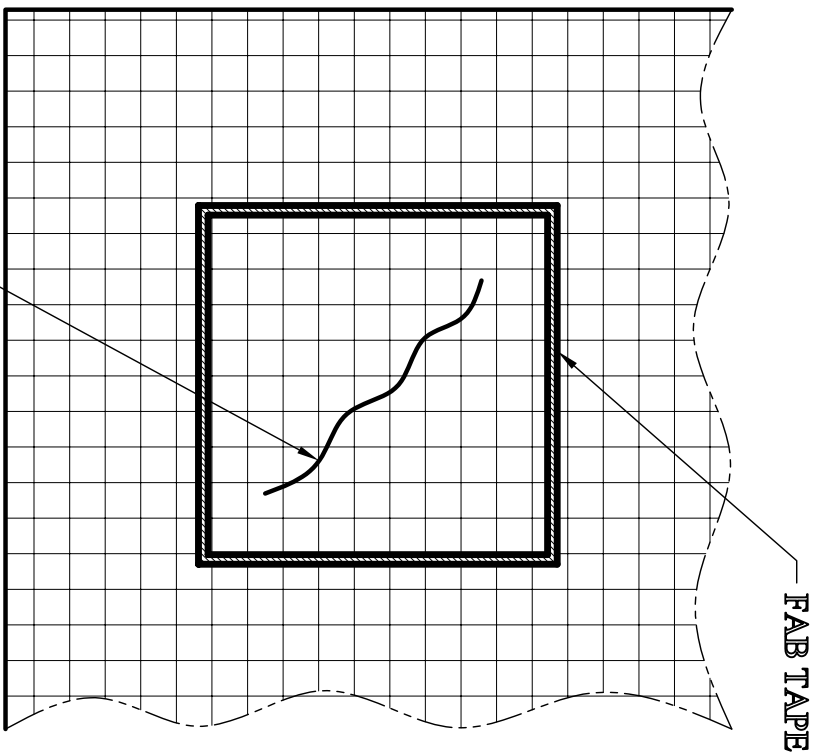

REPAIRING A TEAR

1. CLEAN A 1-2 FOOT AREA ON ALL SIDES OF DAMAGED AREA OF MATERIAL.
2. APPLY A CONTINUOUS STRIP OF FAB TAPE AROUND THE DAMAGED AREA.
3. CUT A PATCH SLIGHTLY LARGER (2-3") THAN THE EXTENT OF THE FAB TAPE.
4. REMOVE THE SECOND LAYER OF RELEASE PAPER AND SECURE THE PATCH TO THE TAPE.

NOTE: This document provides information related to the installation of "FAB TAPE" and related components. This document does not attempt to address all aspects of an installation for all applications. The information presented is general information in order to familiarize the individual with the overall scope of the project.



REEF
INDUSTRIES, INC.

VAPOR RETARDER ATTACHMENT TO STEM WALL W/PIPEBOOT DETAIL

VAPOR RETARDER ATTACHMENT TO WALL RC 04-29

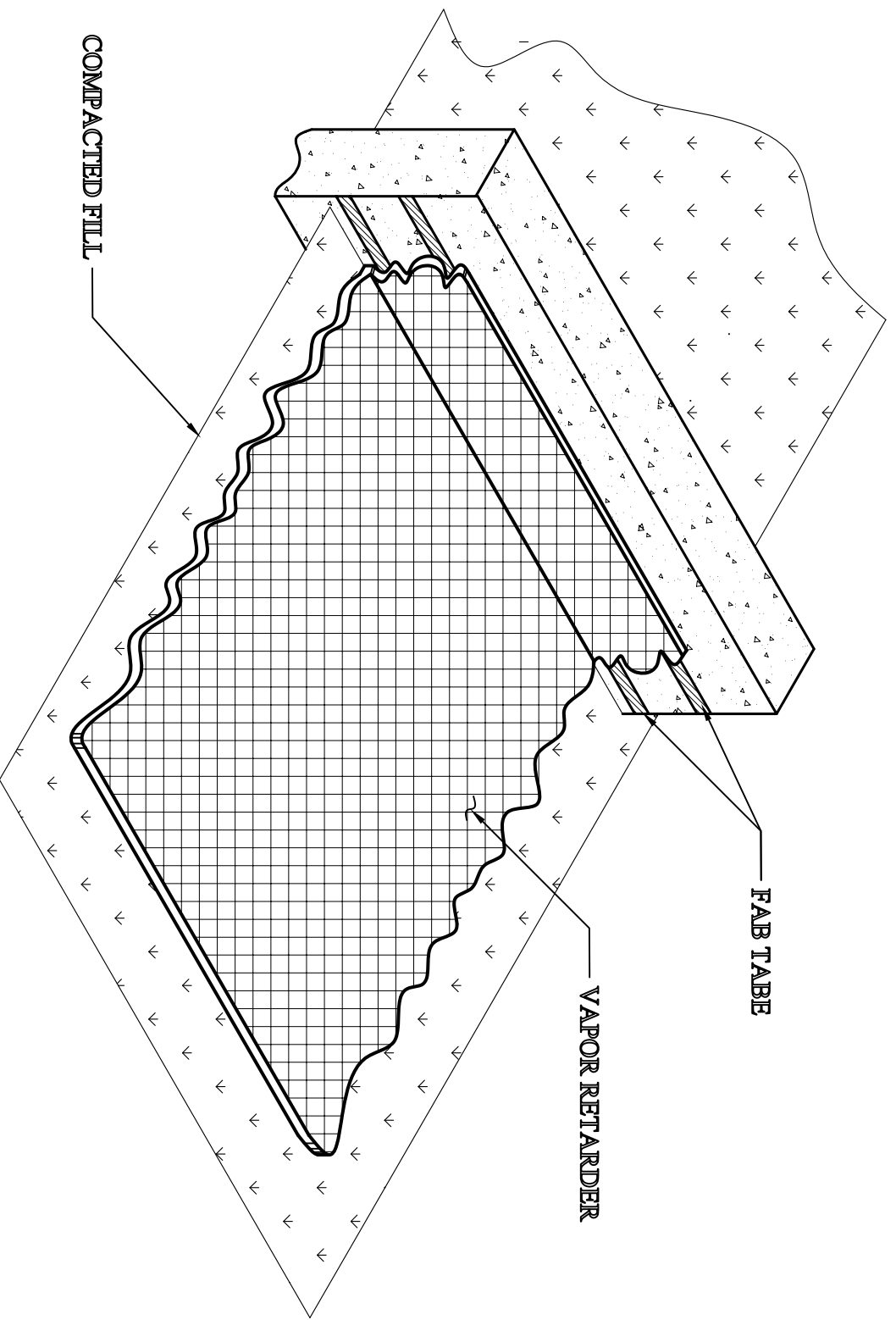

NOTES

1. DIRT AND LOOSE FINES SHOULD BE REMOVED FROM THE INSIDE FACE OF THE STEMWALL
 2. APPLY A ROW OF FAB TAPE ON THE STEM WALL JUST BELOW THE FINISHED FLOOR SURFACE.
 3. REMOVE RELEASE LINER ON THE FAB TAPE AND SECURE THE VAPOR RETARDER TO THE TAPE. INSURE THAT SUFFICIENT SLACK IS AVAILABLE AT THE TRANSITION BETWEEN THE FILL AND THE WALL TO PREVENT ALTERNATE REFERENCE: ASTM E-1643
- THE VAPOR RETARDER FROM BEING SEPARATED FROM THE TAPE.



REEF
INDUSTRIES, INC

DETAIL - VAPOR RETARDER

DETAIL - VAPOR RETARDER RC 4-24.dwg

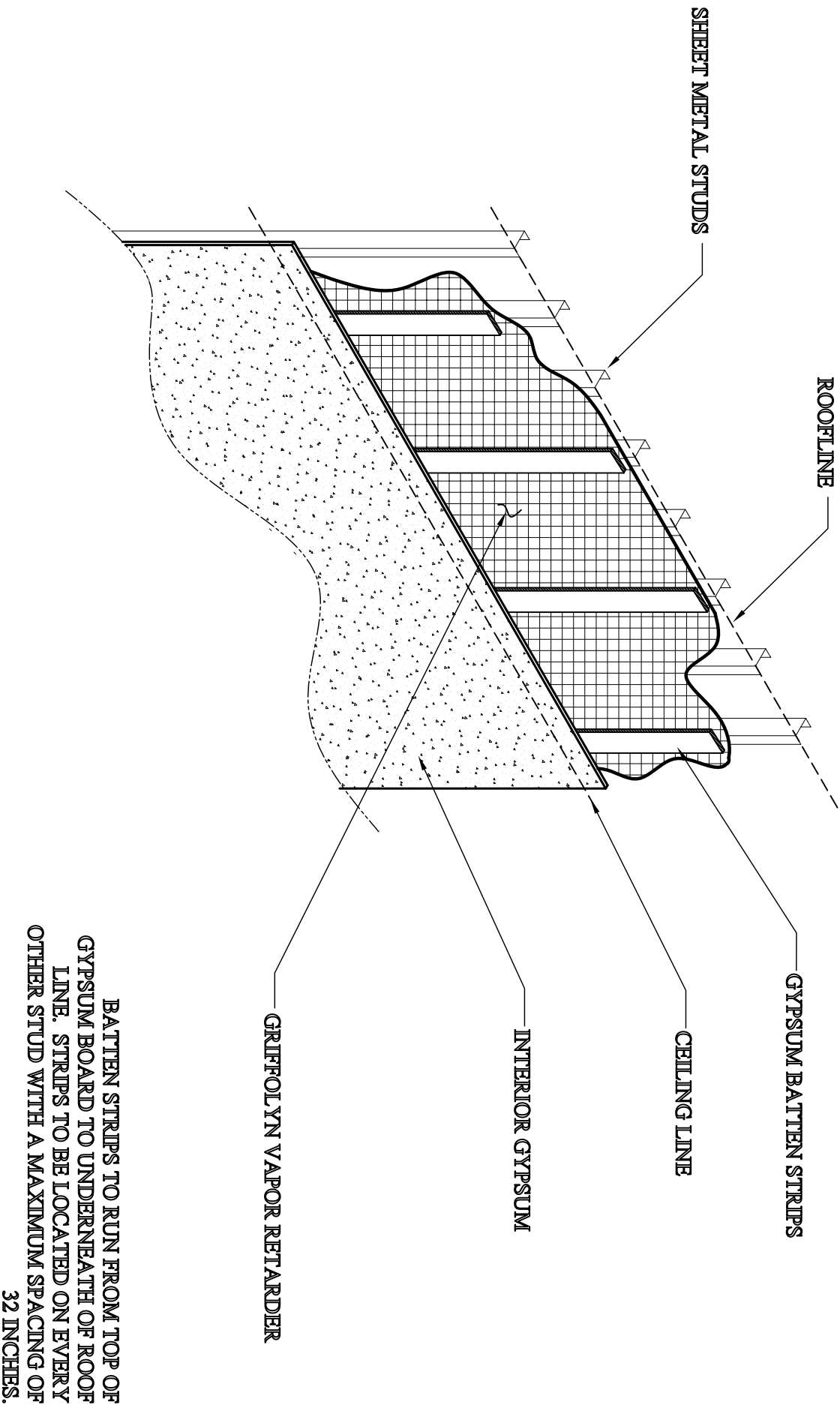

NOTE: This document provides information related to the installation of "Fabtape" and related components. This document does not attempt to address all aspects of an installation for all application. The information presented is general information in order to familiarize the individual with the overall scope of the project.

Griffolyn[®] Griff Tape/FR

General Installation Instructions

The surfaces to be taped should be clean and dry. The tape will not adhere if the surfaces are not properly prepared. Dirty or wet surfaces should be completely cleaned with water, paper towels, dry rags or other materials that will prepare the surface for the tape. Accumulations of dust should also be removed to insure a secure seam.

To make a taped seam, the two panels should be overlapped a minimum of 4 inches. The edges to be joined should be smooth and foldovers or wrinkles should be removed. The exposed edge of the top panel should end up in the center of the tape as it is applied. Apply the tape so that half of the tape is on the top panel and half on the bottom panel. Firm hand pressure is sufficient to bond the tape to the material.

The product obtains optimum adhesion when the surfaces to be bonded are warm. The surfaces should be above 40° F to insure an acceptable bond. In order to obtain a bond at lower temperatures, external heat may be required. The use of an industrial style hot air blower is one recommended method. Extra care should be taken when attempting to install tape at temperatures below 32° F.



PIPE CLUSTER

GRIFFOLYN REPAIR RC 7-9.dwg

DWG 1 OF 2

VAPOR RETARDER WILL BE CUT AROUND CLUSTER TO ALLOW PIPES TO PASS THROUGH LINER

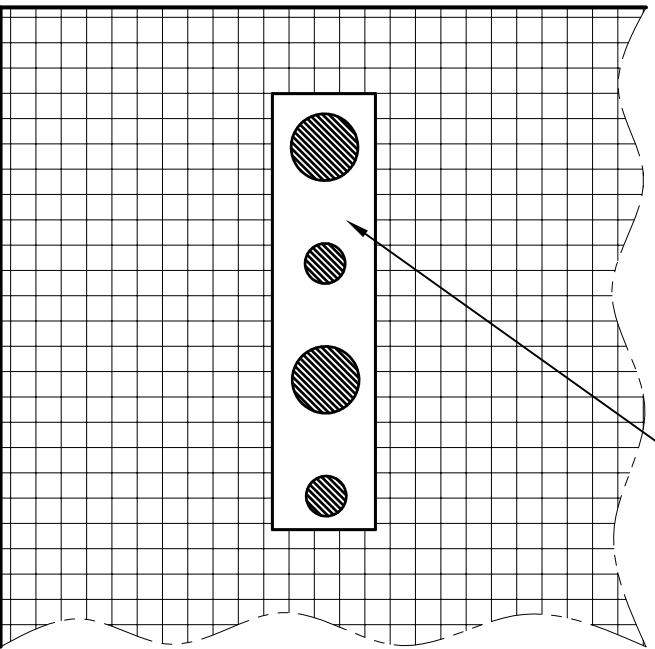

VIEW 1

ON A PIECE OF EXTRA VAPOR BARRIER MATERIAL, MARK PIPE LAYOUT.

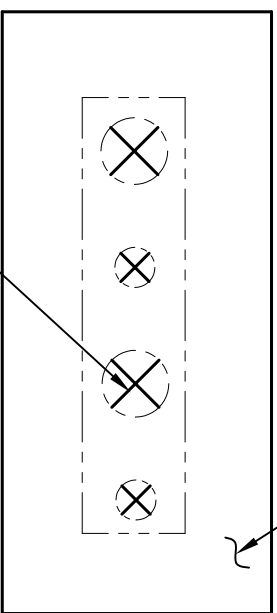

VIEW 2

"X" REPRESENTS A SLIT ON THE MATERIAL. DO NOT OVERSIZE SLITS, MAKE SLIT SLIGHTLY SMALLER THAN PIPE SEE VIEW A-A

VIEW A-A

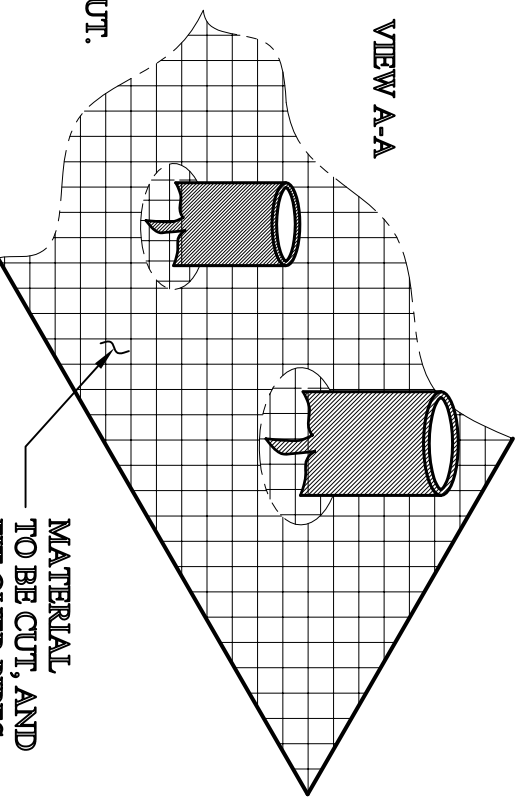

MATERIAL TO BE CUT, AND FIT OVER PIPES

RECOMMENDATIONS OF VAPOR RETARDER INSTALLATION ON AREAS WHERE PIPE CLUSTER ARE PRESENT.

1. ON AN ADDITIONAL PIECE OF VAPOR RETARDER MATERIAL MARK PIPE LAYOUT.
2. START AT CENTER OF PIPE CLUSTER AND WORK OUTWARDS. ALLOW ENOUGH SPACE IN BETWEEN PIPE MARKINGS SO MATERIAL IS NOT BEING STRETCHED.



PIPE CLUSTER

GRIFFOLYN REPAIR RC 7-9.dwg

APPLY FLAP OVER PIPES,
ENSURING THE PRE-MARKED
PIPE ORDINATION IS ALIGNMENT
WITH PIPES

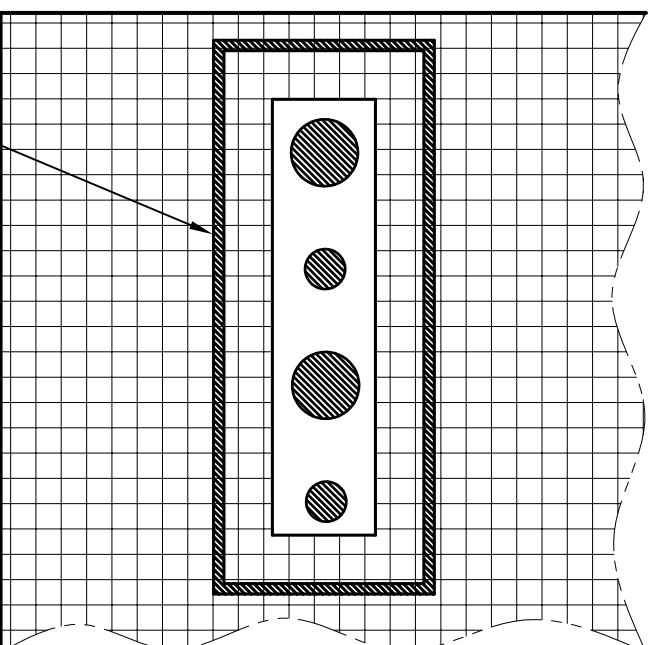
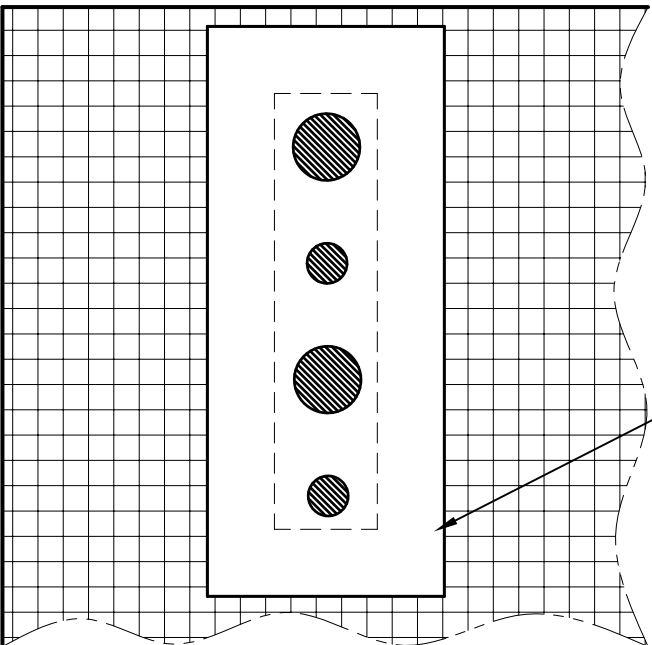

FAB TAPE WILL BE PLACED,
ON TOP SIDE OF LINER, CONTINUES
AROUND THE OPENING

RECOMMENDATIONS OF VAPOR RETARDER INSTALLATION ON AREAS
WHERE PIPE CLUSTER ARE PRESENT.

3. ONCE THE SLITS ARE CUT SLIDE MATERIAL DOWN THE PIPE AND SECURE AGAINST SUBGRADE. USE CAULK OR FAB TAPE TO SEAL THE OPENING OF THE MATERIAL TO THE PIPE.
4. USE FAB TAPE TO SEAL VAPOR BARRIER TO THE MAIN PANEL

