

**IBC 2009/2012
COMPLIANT**



ICC
ESTM
ESR #2507

ICC
ESTM
ESR # 3054

CLASSIFIED
C **UL** US

SFSTM
SUPREME FRAMING SYSTEM

Supreme Framing System

Product Catalog

The Benefits of Supreme Framing System™ Speak for Themselves



What is the Supreme Framing System™?

Supreme Framing System™ stud and track is a design that uses thinner steel and superior 57 ksi yield strength when compared to traditional material. Supreme Framing System™ is available nationally through multiple independent steel stud manufacturers.

- Complies with 2009 and 2012 IBC
- Multiple UL approved fire-rated assemblies
- Excellent acoustical performance
- 57 ksi steel reduces screw stripping
- Fastens with sharp point screws (30EQD and D20)
- Wider flanges for screw placement
- Full line of Supreme Framing accessories
 - Hat Channel and Z-Furring
 - Slotted Track
 - Custom Brake Shapes

Supreme is Certified!

All inspections and testing for the Supreme Steel Framing System Association (SSFSA) are provided by Architectural Testing, Inc. SSFSA sponsors a third-party certification program that requires products to be continually audited to ensure consistent quality and compliance to ASTM C645, C955, and IBC Codes.

Stud and track products must be tested twice per year on unannounced visits. Steel is chemically stripped and tested for coating weight and bare metal thickness. The dimensional properties of the stud are also measured. All requirements must be satisfied in order to be certified code compliant. All members of the SSFSA must satisfy the requirements each time they are audited.

All certified Supreme Steel products has a label showing that it is third-party certified. Labels may be located on bundles or each framing member. The third-party certification label guarantees to the contractor and owner that materials are high quality and code compliant.



Look for the sticker!

Third-party certified code compliant by nationally recognized Architectural Testing, Inc.

Table of Contents

| | |
|---|-------------------|
| Technical Information | 4 |
| Nomenclature | 4 |
| Supreme Stud Profiles | 4 |
| General Notes for All Tables | 5 |
| Steel Thickness and Stiffening Lip Length | 5 |
| Screw and Weld Capacities | 6 |
| Web Depth-to-Thickness Ratios Table | 7 |
| Section Property Symbols | 7 |
| Definitions of Section Property Symbols | 7 |
| Section Properties | 8 |
| Supreme Framing Studs (SFS) | 8 |
| Supreme Framing Track (SFT) | 9-10 |
| Composite Interior Wall Heights | 11 |
| Non-Composite Interior Wall Heights | 12-13 |
| Curtain Wall Limiting Heights | 14-16 |
| Combined Axial and Lateral Loads | 17-19 |
| Web Crippling Loads | 20 |
| Web Crippling Allowable Loads | 20 |
| Web Crippling Conditions | 20 |
| Ceiling Spans | 21 |
| Ceiling Span Deflection Limits | 21 |
| Mid-Span Bracing Details | 21 |
| Hat Channel Section Properties | 22-23 |
| Hat Channel Section Properties | 22 |
| Hat Channel Span Tables | 22-23 |
| Supreme Acoustical Performance Testing | 23 |
| Supreme Fire-Rated Assemblies | 24 |
| UL Approved Designs | 24 |
| Supreme Deep Leg Deflection Track | 25 |
| Supreme Framing Accessories | 26-27 |
| Supreme Slotted Track | 26 |
| Supreme Slotted Track UL Specifications | 26 |
| Supreme Z-Furring | 27 |
| Supreme Custom Shapes | 27 |
| SCAFCO Locations | Back Cover |

LEED Credits

MR Credit 2 - Construction Waste Management (1-2 points)
 MR Credit 4 - Recycled Content (1-2 points)
 MR Credit 5 - Regional Materials (1-2 points)

ICC-ES Code Approvals

ICC-ES ESR2507: 30EQD and 33EQD
 ICC-ES ESR3054: 43EQS

Independent Product Certification

- Code Compliance - ICC Evaluation Services, LLC
- Fire Testing - Underwriters Laboratories, Inc.
- Sound Ratings - Riverbank Acoustical Laboratories
- Third-Party Testing - Architectural Testing, Inc.
- Structural Testing - O.S.U. (Oregon State University) STAR Laboratories
- Structural Engineer - DEVCO Engineering

Code Approvals, Performance Standards, and Product Certifications

AISI's "North American Specification for the Design of Cold-Formed Steel Structural Members"

American Society for Testing and Materials (ASTM)

- A653 - Standard Specification for Steel Sheet, Zinc-Coated (Galvanized) by the Hot-Dip Process
- A1003 - Standard Specification for Steel Sheet, Carbon, and Metallic-Coated for Cold-Formed Framing Members
- C645 - Standard Specification for Non-Structural Steel Framing Members
- C754 - Standard Specification for Installation of Steel Framing Members to Receive Screw-Attached Gypsum Panel Products
- C955 - Standard Specification for Load-Bearing (Transverse and Axial) Steel Studs, Runners (Tracks), and Bracing or Bridging for Screw Application of Gypsum Panel Products and Metal Plaster Bases
- E72 - Standard Test Methods of Conducting Strength Tests of Panels for Building Construction
- E90 - Standard Test Method for Laboratory Measurement of Airborne Sound Transmission Loss of Building Partitions and Elements
- E119 - Standard Test Methods for Fire Tests of Building Construction and Materials

Nomenclature Example

All SCAFCO products have a four-part identification code that identifies the web depth, flange width, style, and mil thickness.

Member Web Depth

(Example: 6" = **600** × $\frac{1}{100}$ inch)

All member depths are given in $\frac{1}{100}$ inch.

For all "T" sections, member depth is the inside to inside dimension.

Flange Width

(Example: $1\frac{5}{8}$ " = 1.625" ≈ **162** × $\frac{1}{100}$ inch)

All flange widths are given in $\frac{1}{100}$ inch.

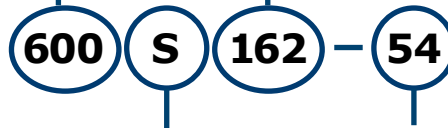

Style

(Example: Stud or Joist section = **S**)

Nomenclature uses the following four characters to designate the profile:

- S** = Stud or Joist Sections
- T** = Track Sections
- U** = Channel Sections
- F** = Furring Channel Sections

Mil Thickness

(Example: 0.054" = **54** mils; 1 mil = $\frac{1}{1000}$ inch)

Mil thickness is the minimum base steel thickness measured in $\frac{1}{1000}$ inch. Minimum base steel thickness represents 95 percent of the design thickness.

Supreme Stud Profiles

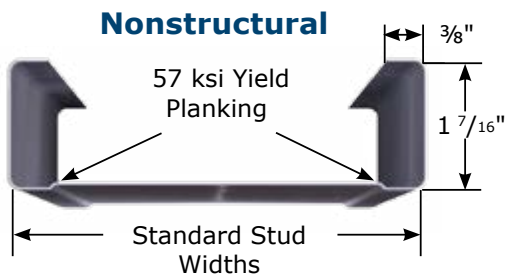

Available Sizes

1 5/8", 2 1/2", 3 1/2", 3 5/8", 4", 5 1/2" and 6"

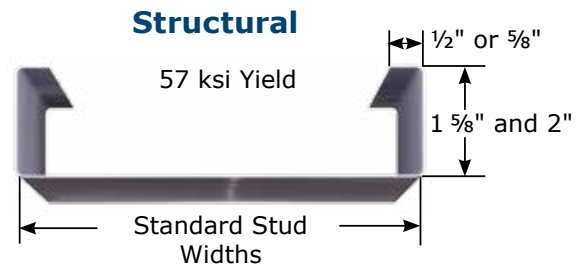

Available Sizes

2 1/2", 3 1/2", 3 5/8", 4", 5 1/2", 6", and *8"

*available in 43EQS only

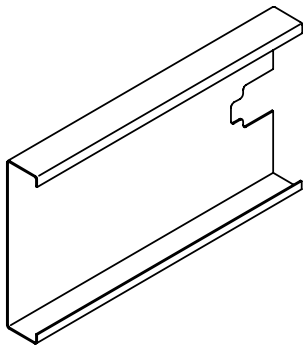

**"S" - C-STUD/JOIST
S-SECTIONS**

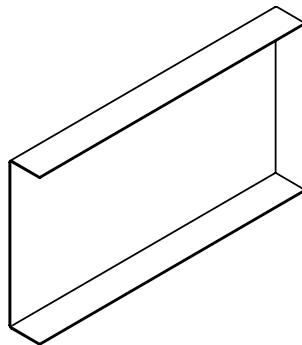

**"T" - TRACK
T-SECTIONS**

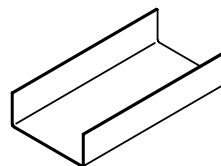

**"U" - CHANNEL
U-SECTIONS**

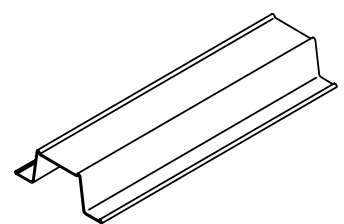

**"F" - FURRING CHANNEL
F-SECTIONS**

General Notes for All Tables

- The values in this catalog are based on the 2007 edition of North American Specification for the Design of Cold-Formed Steel Structural Members, AISI S100-07 as referenced by 2009 International Building Code (IBC) and AISI S100-07 with supplement S2-10 as referenced by 2012 IBC.
- Where AISI S100 is referenced, it is the North American Specification for the Design of Cold-Formed Steel Structural Members, S100-07 and AISI S100-07 with Supplement S2-10, as applicable with U.S. provisions.
- The structural properties included herein have been computed based on allowable strength design (ASD) method.
- Distortional buckling calculations are based on $K\phi = 0$.
- The effective moment of inertia for deflection is calculated at a stress that results in a section modulus such that the stress times the section modulus at that stress is equal to the allowable moment. AISI S100 Procedure I for serviceability determination has been used.
- Conditions with loads that exceed the 10 psf limit for nonstructural members require a G60 galvanized coating.
- When provided, factory punchouts will be located along the center line of the webs of the stud members and will have a minimum center-to-center spacing of 24". Punchouts for members less than 2 1/2" deep are a maximum of 1 1/2" wide x 4 1/2" long. Members with depths 2 1/2" and smaller are maximum 3/4" wide x 4 1/2" long. Any configuration or combination of holes that fit within the punchout width and length limitations mentioned above shall be permitted; other punchout configurations and locations not in compliance with limitations listed above must be approved by a design professional. Values herein are based on punchout configuration and location as illustrated below:

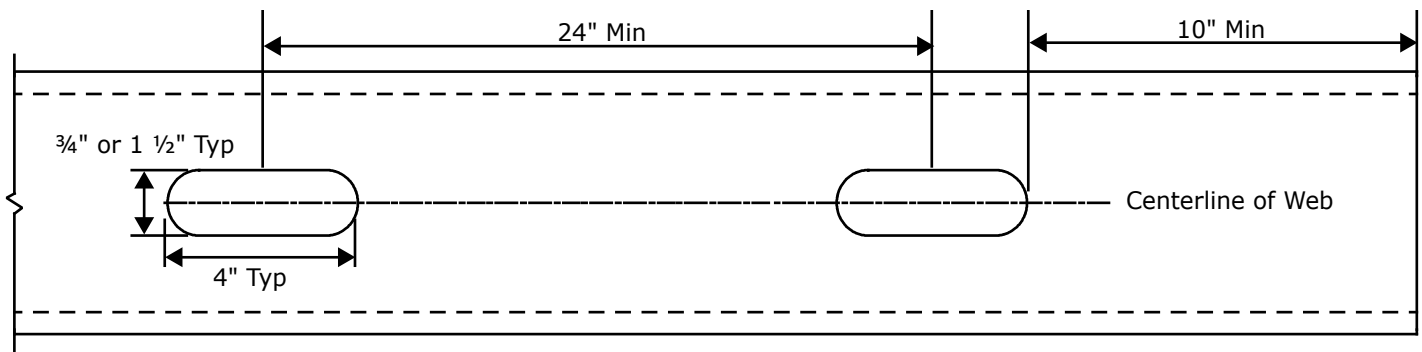

Steel Thickness and Stiffening Lip Length

| Steel Thickness Table | | | | |
|-----------------------|-------------------------------------|------------------------------------|---------------------------------|----------------------|
| Designation | Minimum Thickness ¹ (in) | Design Thickness ¹ (in) | Design Inside Corner Radii (in) | Galvanized Thickness |
| D20 | 0.0179 | 0.0188 | 0.0844 | G40 |
| 30EQD | 0.0223 | 0.0235 | 0.0820 | G40 |
| 33EQD | 0.0223 | 0.0235 | 0.0820 | G60 |
| 33EQS | 0.0280 | 0.0295 | 0.0790 | G60 |
| 43EQS | 0.0380 | 0.0400 | 0.0712 | G60 |

| Stiffening Lip Length | | |
|-----------------------|--------------|----------------------------|
| Member | Flange Width | Stiffening Lip Length (in) |
| S143 | 1 7/16" | 0.375 |
| S162 | 1 3/4" | 0.500 |
| S200 | 2" | 0.625 |

¹Minimum thickness represents 95% of the design thickness and is the minimum acceptable thickness delivered to the jobsite based on Section A2.4 of AISI S100.

Screw and Weld Capacities

Screw Table Notes

- Capacities based on the AISI S100 Section E4 specification.
- When connecting materials of different steel thicknesses or tensile strengths, use the lowest values. Tabulated values assume two sheets of equal thickness are connected.
- Capacities are based on Allowable Strength Design (ASD) and include safety factor of 3.0.
- Where multiple fasteners are used, screws are assumed to have a center-to-center spacing of at least 3 times the nominal diameter (d).
- Screws are assumed to have a center-of-screw to edge-of-steel dimension of at least 1.5 times the nominal diameter (d) of the screw.
- Tension capacity is based on the lesser of pull-out capacity in sheet closest to screw tip, or pull-over capacity for sheet closest to screw head (based on head diameter shown).
- For all tension values shown in this table, pull-over values have been reduced by 50 percent assuming eccentrically loaded connections that produce a non-uniform pull-over force on the fastener.
- Values are for pure shear or tension loads. See AISI S100 Section E4.5 for combined shear and pull-over.
- Higher values, especially for screw strength, may be obtained by specifying screws from a specific manufacturer.
- Shear and tension data for screws was developed with the assistance of the Wei-Wen Yu Center for Cold-Formed Steel Structures (CCFSS), using manufacturers' data and evaluation reports available at the time of publication.

Allowable Screw Connection Capacity (Pounds Per Screw)

| Designation | Thickness (mil) | Design Thickness | Fy Yield (ksi) | Fu Tensile (ksi) | #6 Screw | | #8 Screw | | #10 Screw | | #12 Screw | | 1/4" Screw | |
|-------------|-----------------|------------------|----------------|------------------|------------------------|------------------|-------------------------|------------------|-------------------------|---------|-------------------------|---------|-------------------------|---------|
| | | | | | 0.138" Dia; 0.25" Head | | 0.164" Dia; 0.313" Head | | 0.190" Dia; 0.340" Head | | 0.216" Dia; 0.340" Head | | 0.250" Dia; 0.409" Head | |
| | | | | | Shear | Tension | Shear | Tension | Shear | Tension | Shear | Tension | Shear | Tension |
| D20 | 0.0188 | 57 | 65 | 142 ¹ | 48 | 150 ¹ | 57 | 164 ¹ | 66 | 109 | 75 | - | - | |
| 30EQD | 0.0235 | 57 | 65 | 174 ¹ | 60 | 184 ¹ | 71 | 236 ¹ | 82 | 152 | 93 | - | - | |
| 33EQD | 0.0235 | 57 | 65 | 174 ¹ | 60 | 184 ¹ | 71 | 236 ¹ | 82 | 152 | 93 | - | - | |
| 33EQS | 0.0295 | 57 | 65 | 171 | 75 | 187 | 89 | 201 | 103 | 214 | 117 | 231 | 136 | |
| 43EQS | 0.0400 | 57 | 65 | 270 | 102 | 295 | 121 | 317 | 140 | 338 | 159 | 364 | 184 | |

¹Values are based on testing using AISI S100 procedures.

Weld Table Notes

- Capacities are based the AISI S100 Specification Sections E2.4 for fillet welds and E2.5 for groove welds.
- When connecting materials of different steel thicknesses or tensile strengths, use the lowest values.
- Capacities are based on Allowable Strength Design (ASD) and include appropriate safety factors.
- Weld capacities are based on either 0.938" or 0.125" diameter E60 or E70 electrodes. The use of 0.030" to 0.035" diameter wire electrodes may provide best results.
- Longitudinal capacity is loading in parallel direction of the length of the weld.
- Transverse capacity is loading in perpendicular direction of the length of the weld.
- For flare groove welds, the effective throat of weld is conservatively assumed to be less than 2t.

Weld Capacity (Pounds Per 1" Weld)

| Steel Thickness | Design | Fy (ksi) | Fu (ksi) | Nominal Weld Size | Weld Type | | | |
|-----------------|--------|----------|----------|-------------------|--------------|------------|---------------------------|------------|
| | | | | | Fillet | | Flare Groove | |
| | | | | | Longitudinal | Transverse | Longitudinal ¹ | Transverse |
| 43EQS | 0.0400 | 57 | 65 | 639 | 1106 | 696 | 849 | 849 |

¹For weld lengths greater than 1", equations E2.4-1 and E2.4-2 must be checked.

Web Depth-to-Thickness Ratios ^{2,3,4}

| Web Depth-to-Thickness Ratio | | | | | | | | |
|------------------------------|--------|-----|-------------|------------------|--------|-----|--------|-----|
| Mil Thickness | D20 | | 30EQD/33EQD | | 33EQS | | 43EQS | |
| Design Thickness (in) | 0.0188 | | 0.0235 | | 0.0295 | | 0.04 | |
| Inside Bend Radius (in) | 0.0844 | | 0.082 | | 0.079 | | 0.0712 | |
| Depth (in) | h (in) | h/t | h (in) | h/t | h (in) | h/t | h (in) | h/t |
| 1.625 | 1.419 | 75 | 1.414 | 60 | 1.408 | 47 | 1.403 | 35 |
| 2.5 | 2.294 | 122 | 2.289 | 97 | 2.283 | 77 | 2.278 | 56 |
| 3.5 | 3.294 | 175 | 3.289 | 139 | 3.283 | 111 | 3.278 | 81 |
| 3.625 | 3.419 | 181 | 3.414 | 145 | 3.408 | 115 | 3.403 | 85 |
| 4 | 3.794 | 200 | 3.789 | 161 | 3.783 | 128 | 3.778 | 94 |
| 5.5 | 5.294 | - | 5.289 | 225 ¹ | 5.283 | 179 | 5.278 | 131 |
| 6 | 5.794 | - | 5.789 | 246 ¹ | 5.783 | 196 | 5.778 | 144 |
| 8 | 7.794 | - | 7.789 | - | 7.783 | - | 7.778 | 194 |

¹ h/t exceeds 200

² h value used for h/t calculation is the flat width of the web. For S members, this is the out-to-out member size, minus twice the thickness, minus twice the inside bend radius.

³ h/t values exceeding 260 are marked with a dash (-).

⁴ h/t values in this table apply to S (studs and joists) members only and do not apply to tracks and channels.

Definitions of Section Property Symbols

Gross Properties

- I_x: Moment of inertia of the cross section about the x-axis.
- S_x: Section modulus about the x-axis.
- R_x: Radius of gyration of cross section about the x-axis.
- I_y: Moment of inertia of cross section about the y-axis.
- R_y: Radius of gyration of cross section about the y-axis.

Effective Properties

- I_x: Effective moment of inertia about the x-axis.
- S_{xe}: Effective section modulus about the x-axis.
- M_{al}: Allowable moment based on local buckling.
- M_{ad}: Allowable moment based on distortional buckling, assuming $K\phi = 0$.
- M_a: Allowable moment for track and channel members, based on local buckling only.
- V_{ag}: Allowable strong axis shear away from punchout, calculated in accordance with AISI S100 Section C3.2.1.
- V_{anet}: Allowable strong axis shear at the punchout, calculated in accordance with AISI S100 Section C3.2.2.

Torsional and Other Properties

- J: St. Venant torsional constant. The numbers shown in the tables for J have been multiplied by 1000. The actual values can be obtained by dividing the listed numbers by 1000.
- C_w: Torsional warping constant.
- X_o: Distance from the shear center to the centroid along the principal x-axis.
- m: Distance from shear center to mid-plane of web.
- R_o: Polar radius of gyration of cross section about the shear center.
- β : $1 - (X_o/R_o)^2$
- L_u: Critical unbraced length for lateral-torsional buckling. Members are considered fully braced when unbraced length is less than L_u.
- K ϕ : Distortional buckling moment (M_{ad}) is calculated without the beneficial effect of sheathing to rotational stiffness. $K\phi = 0$.

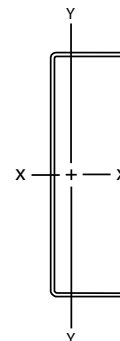

Section Properties - Studs

Table Notes

1. For 33EQD properties, refer to 30EQD values.
2. The centerline bend radius is based on inside corner radii shown in the steel thickness table on page 5.
3. Effective properties incorporate the strength increase from the cold work of forming as applicable per AISI S100 Section A7.2.
4. Tabulated gross properties are based on the full-unreduced cross section of the studs away from punchouts.
5. For deflection calculations, use the effective moment of inertia.
6. Allowable moment is the lesser of M_{al} and M_{ad} . Stud distortional buckling is based on an assumed $K\phi = 0$.
7. See page 5 for additional table notes.

Nonstructural Supreme Studs (SFS) - Section Properties

| Part No. | Design Thickness (in) | Fy (ksi) | Gross Properties | | | | | | | Effective Properties | | | | | | Torsional Properties | | | | | Lu (in) | |
|---------------------------|-----------------------|----------|-------------------------|----------------|-----------------------|-----------------------|---------|-----------------------|---------|------------------------|------------------------|------------|------------|----------|------------|---------------------------|-----------------------|---------|--------|---------|---------|------|
| | | | Area (in ²) | Weight (lb/ft) | Ix (in ⁴) | Sx (in ³) | Rx (in) | Iy (in ⁴) | Ry (in) | Ixe (in ⁴) | Sxe (in ³) | Mal (in-k) | Mad (in-k) | Vag (lb) | VaNet (lb) | Jx1000 (in ⁴) | Cw (in ⁶) | Xo (in) | m (in) | Ro (in) | | β |
| 162SFS-D20 | 0.0188 | 57 | 0.094 | 0.32 | 0.044 | 0.055 | 0.686 | 0.028 | 0.545 | 0.042 | 0.033 | 0.93 | 1.08 | 397 | 131 | 0.011 | 0.022 | -1.365 | 0.779 | 1.622 | 0.292 | 29.1 |
| 162SFS-30EQD | 0.0235 | 57 | 0.117 | 0.40 | 0.055 | 0.068 | 0.684 | 0.035 | 0.543 | 0.052 | 0.048 | 1.63 | 1.70 | 621 | 162 | 0.022 | 0.027 | -1.359 | 0.776 | 1.616 | 0.292 | 29.0 |
| 250SFS-D20 | 0.0188 | 57 | 0.111 | 0.38 | 0.117 | 0.093 | 1.027 | 0.033 | 0.545 | 0.110 | 0.060 | 1.71 | 1.72 | 258 | 196 | 0.013 | 0.049 | -1.217 | 0.719 | 1.683 | 0.477 | 28.1 |
| 250SFS-30EQD | 0.0235 | 57 | 0.138 | 0.47 | 0.145 | 0.116 | 1.025 | 0.041 | 0.542 | 0.136 | 0.090 | 3.06 | 2.68 | 505 | 306 | 0.025 | 0.060 | -1.212 | 0.716 | 1.677 | 0.478 | 28.0 |
| 350SFS-D20 | 0.0188 | 57 | 0.130 | 0.44 | 0.252 | 0.144 | 1.395 | 0.037 | 0.533 | 0.233 | 0.077 | 2.20 | 2.46 | 180 | 159 | 0.015 | 0.097 | -1.088 | 0.662 | 1.847 | 0.653 | 27.6 |
| 350SFS-30EQD | 0.0235 | 57 | 0.161 | 0.55 | 0.313 | 0.179 | 1.392 | 0.046 | 0.531 | 0.304 | 0.112 | 3.83 | 3.84 | 351 | 248 | 0.030 | 0.119 | -1.083 | 0.659 | 1.842 | 0.655 | 27.6 |
| 362SFS-D20 | 0.0188 | 57 | 0.132 | 0.45 | 0.273 | 0.151 | 1.439 | 0.037 | 0.531 | 0.253 | 0.080 | 2.28 | 2.56 | 173 | 164 | 0.016 | 0.104 | -1.074 | 0.655 | 1.873 | 0.671 | 27.6 |
| 362SFS-30EQD | 0.0235 | 57 | 0.164 | 0.56 | 0.339 | 0.187 | 1.437 | 0.046 | 0.529 | 0.331 | 0.116 | 3.97 | 3.98 | 338 | 255 | 0.030 | 0.128 | -1.069 | 0.652 | 1.867 | 0.672 | 27.5 |
| 400SFS-D20 ¹ | 0.0188 | 57 | 0.139 | 0.47 | 0.343 | 0.172 | 1.572 | 0.038 | 0.526 | 0.300 | 0.087 | 2.48 | 2.83 | 156 | 156 | 0.016 | 0.129 | -1.034 | 0.637 | 1.954 | 0.720 | 27.5 |
| 400SFS-30EQD | 0.0235 | 57 | 0.173 | 0.59 | 0.427 | 0.213 | 1.569 | 0.047 | 0.524 | 0.417 | 0.129 | 4.40 | 4.41 | 305 | 275 | 0.032 | 0.159 | -1.029 | 0.634 | 1.949 | 0.721 | 27.4 |
| 550SFS-D20 ² | 0.0188 | 57 | 0.167 | 0.57 | 0.726 | 0.264 | 2.084 | 0.042 | 0.502 | - | - | - | - | - | - | 0.020 | 0.259 | -0.904 | 0.574 | 2.327 | 0.894 | - |
| 550SFS-30EQD ¹ | 0.0235 | 57 | 0.208 | 0.71 | 0.903 | 0.328 | 2.081 | 0.052 | 0.500 | 0.896 | 0.204 | 6.97 | 6.09 | 218 | 218 | 0.038 | 0.320 | -0.900 | 0.571 | 2.322 | 0.850 | 26.9 |
| 600SFS-D20 ² | 0.0188 | 57 | 0.177 | 0.60 | 0.894 | 0.298 | 2.250 | 0.043 | 0.494 | - | - | - | - | - | - | 0.021 | 0.314 | -0.869 | 0.556 | 2.462 | 0.875 | - |
| 600SFS-30EQD ¹ | 0.0235 | 57 | 0.220 | 0.75 | 1.112 | 0.371 | 2.247 | 0.053 | 0.492 | 0.976 | 0.219 | 7.46 | 6.60 | 200 | 200 | 0.041 | 0.388 | -0.864 | 0.553 | 2.457 | 0.876 | 26.7 |

¹Web height-to-thickness ratio exceeds 200. Web stiffeners are required at all support points and concentrated loads.

²Web height-to-thickness ratio exceeds 260. Section is not in compliance with AISI S100 Section B1, but may be used in accordance with SSFSA's published composite wall data for these members.

Structural Supreme Studs (SFS) - Section Properties

| Part No. | Design Thickness (in) | Fy (ksi) | Gross Properties | | | | | | | Effective Properties | | | | | | Torsional Properties | | | | | Lu (in) | |
|-----------------|-----------------------|----------|-------------------------|----------------|-----------------------|-----------------------|---------|-----------------------|---------|------------------------|------------------------|------------|------------|----------|------------|---------------------------|-----------------------|---------|--------|---------|---------|------|
| | | | Area (in ²) | Weight (lb/ft) | Ix (in ⁴) | Sx (in ³) | Rx (in) | Iy (in ⁴) | Ry (in) | Ixe (in ⁴) | Sxe (in ³) | Mal (in-k) | Mad (in-k) | Vag (lb) | VaNet (lb) | Jx1000 (in ⁴) | Cw (in ⁶) | Xo (in) | m (in) | Ro (in) | | β |
| 250SFS162-33EQS | 0.0295 | 57 | 0.191 | 0.65 | 0.202 | 0.162 | 1.029 | 0.075 | 0.626 | 0.195 | 0.134 | 4.57 | 4.17 | 978 | 471 | 0.055 | 0.127 | -1.475 | 0.863 | 1.905 | 0.400 | 33.4 |
| 250SFS162-43EQS | 0.0400 | 57 | 0.257 | 0.88 | 0.270 | 0.216 | 1.025 | 0.100 | 0.622 | 0.270 | 0.185 | 6.32 | 6.26 | 1798 | 636 | 0.137 | 0.166 | -1.463 | 0.856 | 1.892 | 0.402 | 33.4 |
| 250SFS200-43EQS | 0.0400 | 57 | 0.297 | 1.01 | 0.320 | 0.256 | 1.038 | 0.177 | 0.771 | 0.311 | 0.215 | 7.34 | 7.14 | 1798 | 636 | 0.159 | 0.344 | -1.920 | 1.104 | 2.315 | 0.312 | 39.4 |
| 350SFS162-33EQS | 0.0295 | 57 | 0.220 | 0.75 | 0.436 | 0.249 | 1.407 | 0.085 | 0.619 | 0.425 | 0.179 | 6.10 | 6.02 | 696 | 390 | 0.064 | 0.239 | -1.330 | 0.799 | 2.032 | 0.572 | 32.5 |
| 350SFS162-43EQS | 0.0400 | 57 | 0.297 | 1.01 | 0.585 | 0.334 | 1.402 | 0.112 | 0.615 | 0.585 | 0.257 | 8.78 | 9.12 | 1738 | 715 | 0.159 | 0.315 | -1.318 | 0.792 | 2.020 | 0.574 | 32.3 |
| 350SFS200-43EQS | 0.0400 | 57 | 0.337 | 1.15 | 0.688 | 0.393 | 1.429 | 0.200 | 0.771 | 0.675 | 0.301 | 10.28 | 10.33 | 1738 | 715 | 0.180 | 0.617 | -1.754 | 1.035 | 2.389 | 0.461 | 38.4 |
| 362SFS162-33EQS | 0.0295 | 57 | 0.224 | 0.76 | 0.473 | 0.261 | 1.452 | 0.086 | 0.618 | 0.462 | 0.186 | 6.34 | 6.25 | 670 | 402 | 0.065 | 0.257 | -1.314 | 0.792 | 2.054 | 0.591 | 32.4 |
| 362SFS162-43EQS | 0.0400 | 57 | 0.302 | 1.03 | 0.634 | 0.350 | 1.448 | 0.114 | 0.613 | 0.634 | 0.267 | 9.12 | 9.48 | 1674 | 737 | 0.161 | 0.338 | -1.302 | 0.785 | 2.042 | 0.593 | 32.3 |
| 362SFS200-43EQS | 0.0400 | 57 | 0.342 | 1.16 | 0.746 | 0.412 | 1.476 | 0.203 | 0.770 | 0.732 | 0.314 | 10.70 | 10.74 | 1674 | 737 | 0.183 | 0.659 | -1.735 | 1.027 | 2.404 | 0.479 | 38.4 |
| 400SFS162-33EQS | 0.0295 | 57 | 0.235 | 0.80 | 0.593 | 0.297 | 1.589 | 0.088 | 0.613 | 0.581 | 0.206 | 7.04 | 6.95 | 604 | 433 | 0.068 | 0.314 | -1.269 | 0.771 | 2.124 | 0.643 | 32.2 |
| 400SFS162-43EQS | 0.0400 | 57 | 0.317 | 1.08 | 0.796 | 0.398 | 1.584 | 0.118 | 0.609 | 0.796 | 0.298 | 10.16 | 10.57 | 1508 | 795 | 0.169 | 0.413 | -1.258 | 0.765 | 2.112 | 0.645 | 32.0 |
| 400SFS200-43EQS | 0.0400 | 57 | 0.357 | 1.22 | 0.935 | 0.467 | 1.617 | 0.210 | 0.767 | 0.919 | 0.350 | 11.94 | 11.96 | 1508 | 795 | 0.191 | 0.795 | -1.682 | 1.004 | 2.456 | 0.531 | 38.2 |
| 550SFS162-33EQS | 0.0295 | 57 | 0.279 | 0.95 | 1.249 | 0.454 | 2.115 | 0.098 | 0.591 | 1.235 | 0.333 | 11.36 | 9.72 | 433 | 433 | 0.081 | 0.615 | -1.119 | 0.700 | 2.464 | 0.794 | 31.5 |
| 550SFS162-43EQS | 0.0400 | 57 | 0.377 | 1.28 | 1.679 | 0.611 | 2.110 | 0.130 | 0.587 | 1.679 | 0.515 | 17.59 | 14.95 | 1079 | 944 | 0.201 | 0.813 | -1.108 | 0.694 | 2.454 | 0.796 | 31.3 |
| 550SFS200-43EQS | 0.0400 | 57 | 0.417 | 1.42 | 1.951 | 0.709 | 2.162 | 0.234 | 0.748 | 1.933 | 0.589 | 20.10 | 16.90 | 1079 | 944 | 0.223 | 1.516 | -1.502 | 0.921 | 2.737 | 0.699 | 37.7 |
| 600SFS162-33EQS | 0.0295 | 57 | 0.294 | 1.00 | 1.535 | 0.512 | 2.285 | 0.100 | 0.583 | 1.522 | 0.363 | 12.38 | 10.62 | 395 | 395 | 0.085 | 0.743 | -1.078 | 0.680 | 2.592 | 0.827 | 31.3 |
| 600SFS162-43EQS | 0.0400 | 57 | 0.397 | 1.35 | 2.065 | 0.688 | 2.280 | 0.133 | 0.579 | 2.065 | 0.559 | 19.08 | 16.37 | 986 | 976 | 0.212 | 0.983 | -1.067 | 0.673 | 2.583 | 0.829 | 31.1 |
| 600SFS200-43EQS | 0.0400 | 57 | 0.437 | 1.49 | 2.390 | 0.797 | 2.338 | 0.240 | 0.741 | 2.374 | 0.640 | 21.85 | 18.54 | 986 | 976 | 0.233 | 1.822 | -1.452 | 0.897 | 2.850 | 0.741 | 37.5 |
| 800SFS162-43EQS | 0.0400 | 57 | 0.477 | 1.62 | 4.128 | 1.032 | 2.941 | 0.143 | 0.548 | 3.870 | 0.706 | 24.11 | 21.67 | 732 | 732 | 0.255 | 1.862 | -0.931 | 0.603 | 3.133 | 0.912 | 30.4 |
| 800SFS200-43EQS | 0.0400 | 57 | 0.517 | 1.76 | 4.721 | 1.180 | 3.021 | 0.261 | 0.710 | 4.721 | 0.848 | 28.94 | 24.89 | 732 | 732 | 0.276 | 3.400 | -1.283 | 0.814 | 3.358 | 0.854 | 36.9 |

Section Properties - Track

Table Notes

- For 33EQD properties, refer to 30EQD values.
- The centerline bend radius is based on inside corner radii shown in the steel thickness table on page 5.
- Web depth for track sections is equal to the nominal height plus 2 times the design thickness plus the bend radius.
- Hems on nonstructural track sections are ignored. Not all track members are hemmed.
- Effective properties incorporate the strength increase from the cold work of forming as applicable per AISI S100 Section A7.2.
- For deflection calculations, use the effective moment of inertia.
- See page 5 for additional table notes.

Supreme Track (SFT) - Section Properties

| Part No. | Design Thickness (in) | F _y (ksi) | Gross Properties | | | | | | | Effective Properties | | | | Torsional Properties | | | | | |
|------------------------------|-----------------------|----------------------|-------------------------|----------------|-----------------------------------|-----------------------------------|---------------------|-----------------------------------|---------------------|------------------------------------|------------------------------------|-----------------------|----------------------|--|-----------------------------------|---------------------|--------|---------------------|-------|
| | | | Area (in ²) | Weight (lb/ft) | I _x (in ⁴) | S _x (in ³) | R _x (in) | I _y (in ⁴) | R _y (in) | I _{xe} (in ⁴) | S _{xe} (in ³) | M _a (in-k) | V _{ag} (lb) | J _x 1000 (in ⁴) | C _w (in ⁶) | X _o (in) | m (in) | R _o (in) | β |
| 162SFT125-D20 | 0.0188 | 57 | 0.077 | 0.26 | 0.042 | 0.048 | 0.733 | 0.013 | 0.411 | 0.029 | 0.023 | 0.79 | 394 | 0.009 | 0.007 | -0.878 | 0.503 | 1.215 | 0.478 |
| 162SFT125-30EQD | 0.0235 | 57 | 0.097 | 0.33 | 0.052 | 0.060 | 0.734 | 0.016 | 0.410 | 0.038 | 0.031 | 1.06 | 621 | 0.018 | 0.009 | -0.874 | 0.502 | 1.213 | 0.481 |
| 162SFT150-D20 ² | 0.0188 | 57 | 0.087 | 0.30 | 0.049 | 0.056 | 0.749 | 0.021 | 0.496 | - | - | - | - | 0.010 | 0.012 | -1.105 | 0.625 | 1.424 | 0.398 |
| 162SFT150-30EQD | 0.0235 | 57 | 0.109 | 0.37 | 0.061 | 0.070 | 0.749 | 0.027 | 0.496 | 0.041 | 0.032 | 1.09 | 621 | 0.020 | 0.014 | -1.102 | 0.623 | 1.422 | 0.399 |
| 250SFT125-D20 | 0.0188 | 57 | 0.094 | 0.32 | 0.104 | 0.079 | 1.051 | 0.015 | 0.400 | 0.078 | 0.036 | 1.23 | 249 | 0.011 | 0.018 | -0.769 | 0.460 | 1.362 | 0.681 |
| 250SFT125-30EQD | 0.0235 | 57 | 0.118 | 0.40 | 0.130 | 0.099 | 1.052 | 0.019 | 0.399 | 0.100 | 0.053 | 1.80 | 478 | 0.022 | 0.023 | -0.765 | 0.458 | 1.361 | 0.684 |
| 250SFT125-33EQS | 0.0295 | 57 | 0.148 | 0.50 | 0.164 | 0.124 | 1.053 | 0.023 | 0.398 | 0.130 | 0.077 | 2.61 | 944 | 0.043 | 0.028 | -0.762 | 0.457 | 1.359 | 0.685 |
| 250SFT125-43EQS | 0.0400 | 57 | 0.200 | 0.68 | 0.222 | 0.167 | 1.053 | 0.031 | 0.396 | 0.186 | 0.114 | 3.88 | 1798 | 0.107 | 0.038 | -0.758 | 0.454 | 1.356 | 0.688 |
| 250SFT150-D20 ² | 0.0188 | 57 | 0.104 | 0.35 | 0.120 | 0.092 | 1.077 | 0.025 | 0.488 | - | - | - | - | 0.012 | 0.030 | -0.981 | 0.577 | 1.536 | 0.592 |
| 250SFT150-30EQD | 0.0235 | 57 | 0.129 | 0.44 | 0.150 | 0.114 | 1.077 | 0.031 | 0.487 | 0.108 | 0.052 | 1.79 | 478 | 0.024 | 0.037 | -0.979 | 0.576 | 1.535 | 0.593 |
| 250SFT150-33EQS | 0.0295 | 57 | 0.162 | 0.52 | 0.189 | 0.143 | 1.078 | 0.038 | 0.486 | 0.141 | 0.079 | 2.70 | 944 | 0.047 | 0.046 | -0.976 | 0.574 | 1.533 | 0.595 |
| 250SFT150-43EQS | 0.0400 | 57 | 0.220 | 0.75 | 0.256 | 0.193 | 1.079 | 0.052 | 0.484 | 0.202 | 0.118 | 4.02 | 1798 | 0.117 | 0.062 | -0.971 | 0.572 | 1.530 | 0.597 |
| 250SFT200-D20 ² | 0.0188 | 57 | 0.122 | 0.42 | 0.152 | 0.116 | 1.114 | 0.053 | 0.661 | - | - | - | - | 0.014 | 0.064 | -1.427 | 0.882 | 1.927 | 0.452 |
| 250SFT200-30EQD ² | 0.0235 | 57 | 0.153 | 0.52 | 0.190 | 0.144 | 1.115 | 0.067 | 0.660 | - | - | - | - | 0.028 | 0.080 | -1.424 | 0.816 | 1.926 | 0.453 |
| 250SFT200-33EQS ² | 0.0295 | 57 | 0.192 | 0.65 | 0.239 | 0.181 | 1.116 | 0.083 | 0.659 | - | - | - | - | 0.056 | 0.101 | -1.421 | 0.814 | 1.923 | 0.454 |
| 250SFT200-43EQS | 0.0400 | 57 | 0.260 | 0.88 | 0.314 | 0.244 | 1.117 | 0.112 | 0.657 | 0.229 | 0.124 | 4.22 | 1798 | 0.139 | 0.136 | -1.416 | 0.812 | 1.919 | 0.456 |
| 350SFT125-D20 | 0.0188 | 57 | 0.113 | 0.38 | 0.219 | 0.121 | 1.394 | 0.017 | 0.383 | 0.173 | 0.051 | 1.73 | 175 | 0.013 | 0.038 | -0.675 | 0.418 | 1.595 | 0.821 |
| 350SFT125-30EQD | 0.0235 | 57 | 0.141 | 0.48 | 0.275 | 0.151 | 1.396 | 0.021 | 0.381 | 0.221 | 0.074 | 2.51 | 338 | 0.026 | 0.048 | -0.673 | 0.417 | 1.595 | 0.822 |
| 350SFT125-33EQS | 0.0295 | 57 | 0.177 | 0.60 | 0.345 | 0.190 | 1.396 | 0.026 | 0.380 | 0.286 | 0.114 | 3.87 | 668 | 0.051 | 0.060 | -0.670 | 0.415 | 1.595 | 0.823 |
| 350SFT125-43EQS | 0.0400 | 57 | 0.240 | 0.82 | 0.467 | 0.256 | 1.396 | 0.034 | 0.378 | 0.404 | 0.184 | 6.28 | 1661 | 0.128 | 0.080 | -0.666 | 0.413 | 1.592 | 0.825 |
| 350SFT150-D20 ² | 0.0188 | 57 | 0.122 | 0.42 | 0.250 | 0.138 | 1.431 | 0.027 | 0.472 | - | - | - | - | 0.014 | 0.063 | -0.873 | 0.531 | 1.741 | 0.749 |
| 350SFT150-30EQD | 0.0235 | 57 | 0.153 | 0.52 | 0.313 | 0.172 | 1.431 | 0.034 | 0.471 | 0.238 | 0.074 | 2.51 | 338 | 0.028 | 0.078 | -0.871 | 0.530 | 1.740 | 0.749 |
| 350SFT150-33EQS | 0.0295 | 57 | 0.192 | 0.65 | 0.393 | 0.216 | 1.432 | 0.042 | 0.470 | 0.308 | 0.113 | 3.85 | 668 | 0.056 | 0.098 | -0.868 | 0.529 | 1.739 | 0.751 |
| 350SFT150-43EQS | 0.0400 | 57 | 0.260 | 0.88 | 0.533 | 0.292 | 1.432 | 0.057 | 0.468 | 0.437 | 0.191 | 6.50 | 1661 | 0.139 | 0.132 | -0.864 | 0.526 | 1.736 | 0.753 |
| 350SFT200-D20 ² | 0.0188 | 57 | 0.141 | 0.48 | 0.311 | 0.172 | 1.485 | 0.060 | 0.649 | - | - | - | - | 0.017 | 0.136 | -1.293 | 0.765 | 2.073 | 0.611 |
| 350SFT200-30EQD ² | 0.0235 | 57 | 0.176 | 0.60 | 0.389 | 0.215 | 1.486 | 0.074 | 0.649 | - | - | - | - | 0.033 | 0.170 | -1.291 | 0.763 | 2.072 | 0.612 |
| 350SFT200-33EQS ² | 0.0295 | 57 | 0.221 | 0.75 | 0.489 | 0.269 | 1.487 | 0.093 | 0.647 | - | - | - | - | 0.064 | 0.213 | -1.288 | 0.762 | 2.071 | 0.613 |
| 350SFT200-43EQS | 0.0400 | 57 | 0.300 | 1.02 | 0.664 | 0.363 | 1.487 | 0.125 | 0.646 | 0.494 | 0.201 | 6.85 | 1661 | 0.160 | 0.287 | -1.283 | 0.759 | 2.067 | 0.615 |
| 362SFT125-D20 | 0.0188 | 57 | 0.115 | 0.39 | 0.237 | 0.126 | 1.436 | 0.017 | 0.380 | 0.188 | 0.053 | 1.80 | 169 | 0.014 | 0.042 | -0.665 | 0.413 | 1.627 | 0.833 |
| 362SFT125-30EQD | 0.0235 | 57 | 0.144 | 0.49 | 0.297 | 0.158 | 1.437 | 0.021 | 0.379 | 0.240 | 0.076 | 2.60 | 326 | 0.027 | 0.052 | -0.663 | 0.412 | 1.628 | 0.834 |
| 362SFT125-33EQS | 0.0295 | 57 | 0.181 | 0.61 | 0.374 | 0.199 | 1.438 | 0.026 | 0.378 | 0.311 | 0.117 | 4.00 | 644 | 0.052 | 0.065 | -0.660 | 0.411 | 1.627 | 0.835 |
| 362SFT125-43EQS | 0.0400 | 57 | 0.245 | 0.83 | 0.506 | 0.268 | 1.438 | 0.035 | 0.376 | 0.439 | 0.194 | 6.61 | 1603 | 0.131 | 0.087 | -0.656 | 0.408 | 1.625 | 0.837 |
| 362SFT150-D20 ² | 0.0188 | 57 | 0.125 | 0.42 | 0.271 | 0.144 | 1.474 | 0.028 | 0.470 | - | - | - | - | 0.015 | 0.067 | -0.861 | 0.526 | 1.770 | 0.763 |
| 362SFT150-30EQD | 0.0235 | 57 | 0.156 | 0.53 | 0.338 | 0.180 | 1.474 | 0.034 | 0.469 | 0.258 | 0.076 | 2.60 | 326 | 0.029 | 0.085 | -0.859 | 0.525 | 1.769 | 0.764 |
| 362SFT150-33EQS | 0.0295 | 57 | 0.195 | 0.66 | 0.425 | 0.226 | 1.475 | 0.043 | 0.468 | 0.335 | 0.117 | 3.98 | 644 | 0.057 | 0.106 | -0.857 | 0.523 | 1.768 | 0.765 |
| 362SFT150-43EQS | 0.0400 | 57 | 0.265 | 0.90 | 0.576 | 0.305 | 1.475 | 0.057 | 0.466 | 0.474 | 0.201 | 6.85 | 1603 | 0.141 | 0.142 | -0.852 | 0.521 | 1.766 | 0.767 |
| 362SFT200-D20 ² | 0.0188 | 57 | 0.143 | 0.49 | 0.336 | 0.179 | 1.530 | 0.060 | 0.648 | - | - | - | - | 0.017 | 0.147 | -1.278 | 0.759 | 2.096 | 0.628 |
| 362SFT200-30EQD ² | 0.0235 | 57 | 0.179 | 0.61 | 0.420 | 0.224 | 1.531 | 0.075 | 0.647 | - | - | - | - | 0.033 | 0.184 | -1.276 | 0.758 | 2.095 | 0.629 |
| 362SFT200-33EQS ² | 0.0295 | 57 | 0.225 | 0.77 | 0.528 | 0.281 | 1.532 | 0.094 | 0.646 | - | - | - | - | 0.065 | 0.230 | -1.273 | 0.756 | 2.094 | 0.630 |
| 362SFT200-43EQS | 0.0400 | 57 | 0.305 | 1.04 | 0.716 | 0.379 | 1.532 | 0.126 | 0.644 | 0.536 | 0.208 | 7.10 | 1603 | 0.163 | 0.310 | -1.268 | 0.753 | 2.090 | 0.632 |

¹Web height-to-thickness ratio exceeds 200. Web stiffeners are required at all support points and concentrated loads.

²Web height-to-thickness ratio exceeds 260 or flange width-to-thickness ratio exceeds 60. Section is not in compliance with AISI S100 Section B1, but may be used in accordance with SSFSA's published composite wall data for these members.

Section Properties continued on next page

Section Properties continued

| Supreme Track (SFT) - Section Properties | | | | | | | | | | | | | | | | | | | |
|--|-----------------------|----------|-------------------------|----------------|-----------------------|-----------------------|---------|-----------------------|---------|------------------------|------------------------|-----------|----------|---------------------------|-----------------------|---------|--------|---------|-------|
| Part No. | Design Thickness (in) | Fy (ksi) | Gross Properties | | | | | | | Effective Properties | | | | Torsional Properties | | | | | |
| | | | Area (in ²) | Weight (lb/ft) | Ix (in ⁴) | Sx (in ³) | Rx (in) | Iy (in ⁴) | Ry (in) | Ixe (in ⁴) | Sxe (in ³) | Ma (in-k) | Vag (lb) | Jx1000 (in ⁴) | Cw (in ⁶) | Xo (in) | m (in) | Ro (in) | β |
| 400SFT125-D20 ¹ | 0.0188 | 57 | 0.122 | 0.42 | 0.297 | 0.144 | 1.560 | 0.017 | 0.374 | 0.239 | 0.058 | 1.98 | 153 | 0.014 | 0.052 | -0.637 | 0.400 | 1.726 | 0.864 |
| 400SFT125-30EQD | 0.0235 | 57 | 0.153 | 0.52 | 0.373 | 0.181 | 1.562 | 0.021 | 0.373 | 0.305 | 0.084 | 2.87 | 295 | 0.028 | 0.065 | -0.635 | 0.399 | 1.727 | 0.865 |
| 400SFT125-33EQS | 0.0295 | 57 | 0.192 | 0.65 | 0.468 | 0.226 | 1.562 | 0.027 | 0.372 | 0.394 | 0.129 | 4.39 | 583 | 0.056 | 0.081 | -0.632 | 0.397 | 1.726 | 0.866 |
| 400SFT125-43EQS | 0.0400 | 57 | 0.260 | 0.88 | 0.634 | 0.305 | 1.562 | 0.036 | 0.370 | 0.556 | 0.224 | 7.65 | 1450 | 0.139 | 0.109 | -0.628 | 0.395 | 1.724 | 0.867 |
| 400SFT150-D20 ² | 0.0188 | 57 | 0.132 | 0.45 | 0.338 | 0.164 | 1.601 | 0.028 | 0.463 | - | - | - | - | 0.016 | 0.085 | -0.828 | 0.511 | 1.861 | 0.802 |
| 400SFT150-30EQD | 0.0235 | 57 | 0.153 | 0.52 | 0.373 | 0.181 | 1.562 | 0.021 | 0.373 | 0.305 | 0.084 | 2.87 | 295 | 0.028 | 0.065 | -0.635 | 0.399 | 1.727 | 0.865 |
| 400SFT150-33EQS | 0.0295 | 57 | 0.207 | 0.70 | 0.530 | 0.256 | 1.602 | 0.044 | 0.461 | 0.423 | 0.129 | 4.39 | 583 | 0.060 | 0.132 | -0.824 | 0.508 | 1.860 | 0.804 |
| 400SFT150-43EQS | 0.0400 | 57 | 0.280 | 0.95 | 0.719 | 0.346 | 1.603 | 0.059 | 0.459 | 0.598 | 0.232 | 7.92 | 1450 | 0.149 | 0.178 | -0.819 | 0.506 | 1.858 | 0.806 |
| 400SFT200-D20 ² | 0.0188 | 57 | 0.151 | 0.51 | 0.417 | 0.202 | 1.664 | 0.062 | 0.642 | - | - | - | - | 0.018 | 0.184 | -1.236 | 0.741 | 2.170 | 0.676 |
| 400SFT200-30EQD ² | 0.0235 | 57 | 0.188 | 0.64 | 0.521 | 0.253 | 1.665 | 0.077 | 0.641 | - | - | - | - | 0.035 | 0.229 | -1.234 | 0.740 | 2.169 | 0.676 |
| 400SFT200-33EQS ² | 0.0295 | 57 | 0.236 | 0.80 | 0.655 | 0.316 | 1.666 | 0.097 | 0.640 | - | - | - | - | 0.068 | 0.287 | -1.231 | 0.738 | 2.168 | 0.678 |
| 400SFT200-43EQS | 0.0400 | 57 | 0.320 | 1.09 | 0.888 | 0.428 | 1.666 | 0.130 | 0.638 | 0.674 | 0.229 | 7.82 | 1450 | 0.171 | 0.387 | -1.226 | 0.735 | 2.165 | 0.679 |
| 550SFT125-D20 ² | 0.0188 | 57 | 0.150 | 0.51 | 0.63 | 0.224 | 2.046 | 0.018 | 0.349 | - | - | - | - | 0.018 | 0.108 | -0.546 | 0.354 | 2.146 | 0.935 |
| 550SFT125-30EQD ¹ | 0.0235 | 57 | 0.188 | 0.64 | 0.787 | 0.280 | 2.046 | 0.023 | 0.348 | 0.568 | 0.113 | 3.99 | 213 | 0.035 | 0.134 | -0.545 | 0.353 | 2.146 | 0.936 |
| 550SFT125-33EQS | 0.0295 | 57 | 0.236 | 0.80 | 0.988 | 0.351 | 2.046 | 0.029 | 0.347 | 0.776 | 0.169 | 5.75 | 422 | 0.068 | 0.167 | -0.542 | 0.352 | 2.145 | 0.936 |
| 550SFT125-43EQS | 0.0400 | 57 | 0.320 | 1.09 | 1.339 | 0.474 | 2.046 | 0.038 | 0.345 | 1.160 | 0.284 | 9.70 | 1049 | 0.171 | 0.224 | -0.539 | 0.349 | 2.144 | 0.937 |
| 550SFT150-D20 ² | 0.0188 | 57 | 0.160 | 0.54 | 0.703 | 0.25 | 2.098 | 0.031 | 0.437 | - | - | - | - | 0.019 | 0.176 | -0.72 | 0.458 | 2.26 | 0.899 |
| 550SFT150-30EQD ¹ | 0.0235 | 57 | 0.200 | 0.68 | 0.879 | 0.312 | 2.098 | 0.038 | 0.437 | 0.653 | 0.116 | 3.97 | 213 | 0.037 | 0.219 | -0.718 | 0.457 | 2.260 | 0.899 |
| 550SFT150-33EQS | 0.0295 | 57 | 0.251 | 0.85 | 1.104 | 0.392 | 2.098 | 0.048 | 0.435 | 0.920 | 0.176 | 6.01 | 422 | 0.073 | 0.274 | -0.715 | 0.456 | 2.259 | 0.900 |
| 550SFT150-43EQS | 0.0400 | 57 | 0.340 | 1.16 | 1.496 | 0.529 | 2.099 | 0.064 | 0.433 | 1.291 | 0.313 | 10.70 | 1049 | 0.181 | 0.368 | -0.712 | 0.453 | 2.258 | 0.901 |
| 550SFT200-D20 ² | 0.0188 | 57 | 0.179 | 0.61 | 0.851 | 0.303 | 2.182 | 0.068 | 0.616 | - | - | - | - | 0.021 | 0.380 | -1.095 | 0.677 | 2.518 | 0.811 |
| 550SFT200-30EQD ² | 0.0235 | 57 | 0.223 | 0.76 | 1.064 | 0.378 | 2.183 | 0.085 | 0.615 | - | - | - | - | 0.041 | 0.474 | -1.093 | 0.676 | 2.517 | 0.812 |
| 550SFT200-33EQS ² | 0.0295 | 57 | 0.280 | 0.95 | 1.336 | 0.474 | 2.184 | 0.106 | 0.614 | - | - | - | - | 0.081 | 0.593 | -1.090 | 0.675 | 2.516 | 0.812 |
| 550SFT200-43EQS | 0.0400 | 57 | 0.380 | 1.29 | 1.811 | 0.641 | 2.184 | 0.142 | 0.612 | 1.441 | 0.313 | 10.67 | 1049 | 0.203 | 0.799 | -1.086 | 0.672 | 2.514 | 0.814 |
| 600SFT125-D20 ² | 0.0235 | 57 | 0.160 | 0.54 | 0.776 | 0.254 | 2.204 | 0.019 | 0.342 | - | - | - | - | 0.019 | 0.131 | -0.522 | 0.341 | 2.290 | 0.948 |
| 600SFT125-30EQD ¹ | 0.0235 | 57 | 0.200 | 0.68 | 0.970 | 0.317 | 2.204 | 0.023 | 0.341 | 0.690 | 0.124 | 4.24 | 195 | 0.037 | 0.163 | -0.520 | 0.340 | 2.290 | 0.948 |
| 600SFT125-33EQS ¹ | 0.0295 | 57 | 0.251 | 0.85 | 1.218 | 0.397 | 2.204 | 0.029 | 0.340 | 0.946 | 0.185 | 6.31 | 386 | 0.073 | 0.204 | -0.518 | 0.339 | 2.289 | 0.949 |
| 600SFT125-43EQS | 0.0400 | 57 | 0.340 | 1.16 | 1.650 | 0.537 | 2.204 | 0.039 | 0.338 | 1.420 | 0.313 | 10.67 | 961 | 0.181 | 0.273 | -0.515 | 0.336 | 2.288 | 0.949 |
| 600SFT150-D20 ² | 0.0188 | 57 | 0.169 | 0.58 | 0.864 | 0.282 | 2.259 | 0.031 | 0.429 | - | - | - | - | 0.020 | 0.214 | -0.69 | 0.443 | 2.401 | 0.917 |
| 600SFT150-30EQD ¹ | 0.0235 | 57 | 0.212 | 0.72 | 1.080 | 0.352 | 2.259 | 0.039 | 0.428 | 0.721 | 0.126 | 4.28 | 195 | 0.039 | 0.267 | -0.688 | 0.442 | 2.400 | 0.918 |
| 600SFT150-33EQS ¹ | 0.0295 | 57 | 0.266 | 0.90 | 1.355 | 0.442 | 2.260 | 0.049 | 0.427 | 0.993 | 0.187 | 6.39 | 386 | 0.077 | 0.334 | -0.686 | 0.441 | 2.400 | 0.918 |
| 600SFT150-43EQS | 0.0400 | 57 | 0.360 | 1.22 | 1.837 | 0.597 | 2.260 | 0.065 | 0.425 | 1.500 | 0.318 | 10.86 | 961 | 0.192 | 0.449 | -0.682 | 0.438 | 2.398 | 0.919 |
| 600SFT200-D20 ² | 0.0188 | 57 | 0.188 | 0.64 | 1.039 | 0.339 | 2.350 | 0.069 | 0.607 | - | - | - | - | 0.022 | 0.464 | -1.055 | 0.659 | 2.647 | 0.841 |
| 600SFT200-30EQD ² | 0.0235 | 57 | 0.235 | 0.80 | 1.299 | 0.424 | 2.351 | 0.086 | 0.606 | - | - | - | - | 0.043 | 0.578 | -1.053 | 0.658 | 2.646 | 0.842 |
| 600SFT200-33EQS ² | 0.0295 | 57 | 0.295 | 1.00 | 1.631 | 0.531 | 2.351 | 0.108 | 0.605 | - | - | - | - | 0.086 | 0.724 | -1.050 | 0.656 | 2.645 | 0.842 |
| 600SFT200-43EQS | 0.0400 | 57 | 0.400 | 1.36 | 2.210 | 0.719 | 2.352 | 0.145 | 0.603 | 1.780 | 0.341 | 11.62 | 961 | 0.213 | 0.976 | -1.046 | 0.654 | 2.643 | 0.843 |
| 800SFT125-43EQS ¹ | 0.0400 | 57 | 0.420 | 1.43 | 3.345 | 0.821 | 2.823 | 0.041 | 0.312 | 2.794 | 0.426 | 14.54 | 718 | 0.224 | 0.525 | -0.437 | 0.293 | 2.874 | 0.977 |
| 800SFT150-43EQS ¹ | 0.0400 | 57 | 0.440 | 1.50 | 3.674 | 0.902 | 2.891 | 0.069 | 0.396 | 2.906 | 0.433 | 14.77 | 718 | 0.235 | 0.865 | -0.586 | 0.387 | 2.976 | 0.961 |
| 800SFT200-43EQS ¹ | 0.0400 | 57 | 0.480 | 1.63 | 4.332 | 1.063 | 3.005 | 0.156 | 0.570 | 3.127 | 0.442 | 15.07 | 718 | 0.256 | 1.887 | -0.915 | 0.588 | 3.193 | 0.918 |

¹Web height-to-thickness ratio exceeds 200. Web stiffeners are required at all support points and concentrated loads.

²Web height-to-thickness ratio exceeds 260 or flange width-to-thickness ratio exceeds 60. Section is not in compliance with AISI S100 Section B1, but may be used in accordance with SSFSA's published composite wall data for these members.

See Table Notes on page 7

Composite Interior Wall Heights

Table Notes

1. For 33EQD wall heights, refer to 30EQD values.
2. Allowable composite limiting heights are calculated using ICC-ES AC86-2010. The $\frac{1}{3}$ stress increase for strength was not used.
3. The gypsum board must be applied full height to each stud flange and installed using minimum #6 Type S drywall screws.
4. No fasteners are required for attaching the stud to the track.
5. Stud and bearing must be a minimum of 1".
6. Galvanizing to be G40 minimum for 10 PSF or less, and G60 minimum for greater than 10 PSF lateral loads.

| Composite Interior Wall Heights | | | | | | | | | | | | | | |
|---------------------------------|----------|-----------------|----------|---------|---------|----------|---------|--------|-----------|----------|---------|----------|----------|----------|
| Part No. | Fy (ksi) | Spacing (in) oc | 5 psf | | | 7.5 psf | | | 10 psf | | | 15 psf | | |
| | | | L/120 | L/240 | L/360 | L/120 | L/240 | L/360 | L/120 | L/240 | L/360 | L/120 | L/240 | L/360 |
| 162SFS-D20 | 57 | 16 | 11' 5" | 9' 3" | 8' 3" | 9' 11" | 8' 1" | - | 9' 0" | - | - | - | - | - |
| | 57 | 24 | 9' 11" | 8' 1" | - | 8' 8" | - | - | 7' 11" | - | - | - | - | - |
| 250SFS-D20 | 57 | 16 | 14' 11" | 12' 3" | 10' 8" | 13' 0" | 10' 8" | 9' 2" | 11' 10" | 9' 7" | 8' 3" | 7' 11" | 7' 11" | - |
| | 57 | 24 | 13' 0" | 10' 8" | 9' 2" | 11' 4" | 9' 2" | 7' 11" | 9' 10" f | 8' 4" | - | - | - | - |
| 362SFS-D20 | 57 | 16 | 19' 0" | 15' 11" | 14' 0" | 16' 5" f | 13' 11" | 12' 3" | 14' 3" f | 12' 7" | 11' 1" | 9' 4" f | 9' 4" f | 9' 4" f |
| | 57 | 24 | 16' 5" f | 13' 11" | 12' 3" | 13' 5" f | 12' 1" | 10' 7" | 11' 7" f | 10' 11" | 9' 6" | - | - | - |
| 400SFS-D20 | 57 | 16 | 20' 8" | 17' 0" | 14' 11" | 17' 6" f | 14' 10" | 13' 0" | 15' 2" f | 13' 6" | 11' 10" | 10' 0" f | 10' 0" f | 10' 0" f |
| | 57 | 24 | 17' 6" f | 14' 10" | 13' 0" | 14' 4" f | 12' 11" | 11' 4" | 12' 5" f | 11' 9" | 10' 1" | 8' 2" f | 8' 2" f | 8' 2" f |
| 600SFS-D20 | 57 | 16 | 26' 4" f | 22' 4" | 19' 9" | 21' 6" f | 16' 6" | 17' 3" | 18' 8" f | 17' 9" | 15' 8" | 12' 3" f | 12' 3" f | 12' 3" f |
| | 57 | 24 | 21' 6" f | 19' 6" | 17' 3" | 17' 7" f | 17' 1" | 15' 1" | 15' 3" f | 15' 3" f | 13' 7" | - | - | - |
| 162SFS-30EQD | 57 | 16 | 12' 10" | 10' 2" | 8' 9" | 11' 2" | 8' 9" | - | 10' 2" | - | - | - | - | - |
| | 57 | 24 | 11' 6" | 9' 1" | - | 10' 0" | - | - | 9' 1" | - | - | - | - | - |
| 250SFS-30EQD | 57 | 16 | 15' 7" | 12' 5" | 10' 10" | 13' 8" | 10' 10" | 9' 5" | 12' 5" | 9' 9" | 8' 6" | 9' 3" f | 8' 6" | - |
| | 57 | 24 | 13' 7" | 10' 10" | 9' 5" | 11' 11" | 9' 5" | 8' 3" | 10' 10" | 8' 7" | - | - | - | - |
| 362SFS-30EQD | 57 | 16 | 20' 5" | 15' 8" | 13' 8" | 17' 10" | 13' 8" | 12' 0" | 16' 3" | 12' 5" | 10' 10" | 11' 1" f | 10' 10" | 9' 4" |
| | 57 | 24 | 18' 7" | 14' 3" | 12' 5" | 15' 8" f | 12' 5" | 10' 9" | 13' 3" f | 11' 3" | 9' 8" | 9' 1" f | 9' 1" f | 8' 4" |
| 400SFS-30EQD | 57 | 16 | 20' 9" | 16' 6" | 14' 5" | 18' 2" | 14' 5" | 12' 7" | 16' 6" | 13' 1" | 11' 5" | 11' 5" f | 11' 5" f | 9' 9" |
| | 57 | 24 | 18' 9" | 14' 8" | 12' 10" | 16' 0" f | 12' 10" | 11' 2" | 13' 7" f | 11' 8" | 10' 1" | 9' 4" f | 9' 4" f | 8' 9" |
| 600SFS-30EQD | 57 | 16 | 28' 6" | 21' 6" | 18' 9" | 24' 11" | 18' 9" | 16' 5" | 21' 11" f | 17' 1" | 14' 11" | 13' 4" f | 13' 4" f | 13' 0" |
| | 57 | 24 | 24' 9" | 18' 6" | 16' 6" | 20' 6" f | 16' 2" | 14' 5" | 16' 6" f | 14' 8" f | 13' 1" | 10' 4" f | 10' 4" f | 10' 4" f |

"f" Flexural stress controls allowable height.

Non-Composite Interior Wall Heights

Table Notes

1. For 33EQD wall heights, refer to 30EQD values.
2. Five pounds per square foot (psf), 7.5 psf, and 10 psf loads have **not** been reduced for strength or deflection checks; full lateral load is applied.
3. Limiting heights are based on steel properties only (non-composite) without the contribution of sheathing to strengthen and stiffen the assembly. Properly fastened sheathing is still required for members to be considered fully braced.
4. Web crippling check is based on 1" end bearing.
5. Allowable moment is the lesser of M_{at} and M_{ad} . Stud distortional buckling based on an assumed $K\phi = 0$.
6. See page 5 for additional table notes.

| Non-Composite Interior Wall Heights | | | | | | | | | | | |
|-------------------------------------|----------|------------------------|---------|---------|---------|----------|----------|---------|-----------|-----------|----------|
| Part No. | Fy (ksi) | Spacing (in) on center | 5 psf | | | 7.5 psf | | | 10 psf | | |
| | | | L/120 | L/240 | L/360 | L/120 | L/240 | L/360 | L/120 | L/240 | L/360 |
| 162SFS-D20 | 57 | 12 | 10' 4" | 8' 2" | - | 9' 0" | - | - | - | - | - |
| | 57 | 16 | 9' 5" | - | - | - | - | - | - | - | - |
| | 57 | 24 | - | - | - | - | - | - | - | - | - |
| 250SFS-D20 | 57 | 12 | 14' 3" | 11' 3" | 9' 10" | 12' 4" | 9' 10" | 8' 7" | 10' 8" | 8' 11" | - |
| | 57 | 16 | 12' 11" | 10' 3" | 8' 11" | 10' 8" | 8' 11" | - | 9' 3" | 8' 2" | - |
| | 57 | 24 | 10' 8" | 8' 11" | - | 8' 9" | - | - | - | - | - |
| 350SFS-D20 | 57 | 12 | 17' 1" | 14' 6" | 12' 8" | 14' - 0" | 12' 8" | 11' 1" | 12' 1" | 11' 6" | 10' 1" |
| | 57 | 16 | 14' 10" | 13' 2" | 11' 6" | 12' 1" | 11' 6" | 10' 1" | 10' 6" | 10' 6" | 9' 2" |
| | 57 | 24 | 12' 1" | 11' 6" | 10' 1" | 9' 11" | 9' 11" | 8' 9" | 8' 6" | 8' 6" | - |
| 362SFS-D20 | 57 | 12 | 17' 5" | 15' 2" | 13' 3" | 14' 3" | 13' 2" | 11' 7" | 12' 4" | 11' 10" | 10' 6" |
| | 57 | 16 | 15' 1" | 13' 9" | 12' 0" | 12' 4" | 11' 10" | 10' 6" | 10' 8" | 10' 8" | 9' 7" |
| | 57 | 24 | 12' 4" | 11' 10" | 10' 6" | 10' 1" | 10' 1" | 9' 2" | 8' 5" | 8' 5" | 8' 3" |
| 400SFS-D20 | 57 | 12 | 18' 2" | 15' 9" | 13' 9" | 14' 10" | 13' 9" | 12' 1" | 12' 10" | 12' 6" | 10' 11" |
| | 57 | 16 | 15' 9" | 14' 4" | 12' 6" | 12' 10" | 12' 6" | 10' 11" | 11' 2" | 11' 2" | 9' 11" |
| | 57 | 24 | 12' 10" | 12' 6" | 10' 11" | 10' 6" | 10' 6" | 9' 7" | 9' 1" | 9' 1" | 8' 8" |
| 162SFS-30EQD | 57 | 12 | 11' 0" | 8' 9" | - | 9' 8" | - | - | 8' 9" | - | - |
| | 57 | 16 | 10' 0" | - | - | 8' 9" | - | - | - | - | - |
| | 57 | 24 | 8' 9" | - | - | - | - | - | - | - | - |
| 250SFS-30EQD | 57 | 12 | 15' 4" | 12' 2" | 10' 7" | 13' 5" | 10' 7" | 9' 3" | 12' 2" | 9' 8" | 8' 5" |
| | 57 | 16 | 13' 11" | 11' 1" | 9' 8" | 12' 2" | 9' 8" | 8' 5" | 11' 1" | 8' 9" | - |
| | 57 | 24 | 12' 2" | 9' 8" | 8' 5" | 10' 7" | 8' 5" | - | 9' 5" | - | - |
| 350SFS-30EQD | 57 | 12 | 19' 11" | 15' 10" | 13' 10" | 17' 5" | 13' 10" | 12' 1" | 15' 10" | 12' 7" | 10' 11" |
| | 57 | 16 | 18' 1" | 14' 4" | 12' 7" | 15' 10" | 12' 7" | 10' 11" | 13' 9" | 11' 5" | 9' 11" |
| | 57 | 24 | 15' 10" | 12' 7" | 10' 11" | 13' 0" | 10' 11" | 9' 7" | 11' 3" | 9' 11" | 8' 8" |
| 362SFS-30EQD | 57 | 12 | 20' 6" | 16' 3" | 14' 2" | 17' 11" | 14' 2" | 12' 5" | 16' 3" | 12' 11" | 11' 3" |
| | 57 | 16 | 18' 7" | 14' 9" | 12' 11" | 16' 3" | 12' 11" | 11' 3" | 14' 1" | 11' 9" | 10' 3" |
| | 57 | 24 | 16' 3" | 12' 11" | 11' 3" | 13' 3" | 11' 3" | 9' 10" | 11' 6" | 10' 3" | 8' 11" |
| 400SFS-30EQD | 57 | 12 | 22' 2" | 17' 7" | 15' 4" | 19' 4" | 15' 4" | 13' 5" | 17' 1" | 13' 11" | 12' 2" |
| | 57 | 16 | 20' 2" | 16' 0" | 13' 11" | 17' 1" | 13' 11" | 12' 2" | 14' 10" | 12' 8" | 11' 1" |
| | 57 | 24 | 17' 1" | 13' 11" | 12' 2" | 13' 11" | 12' 2" | 10' 8" | 12' 1" | 11' 1" | 9' 8" |
| 550SFS-30EQD ¹ | 57 | 12 | 28' 5" | 22' 8" | 19' 10" | 23' 3" | 19' 10" | 17' 4" | 20' 1" | 18' 0" | 15' 9" |
| | 57 | 16 | 24' 8" | 20' 7" | 18' 0" | 20' 1" | 18' 0" | 15' 9" | 17' 5" | 16' 4" | 14' 3" |
| | 57 | 24 | 20' 1" | 18' 0" | 15' 9" | 16' 5" | 15' 9" | 13' 9" | 14' 2" | 14' 2" | 12' 6" |
| 600SFS-30EQD ¹ | 57 | 12 | 29' 8" | 23' 7" | 20' 8" | 24' 2" | 20' 8" | 18' 0" | 20' 11" | 18' 9" | 16' 4" |
| | 57 | 16 | 25' 8" | 21' 5" | 18' 9" | 20' 11" | 18' 9" | 16' 4" | 18' 2" e | 17' 0" e | 14' 10" |
| | 57 | 24 | 20' 11" | 18' 9" | 16' 4" | 17' 1" e | 16' 4" e | 14' 3" | 14' 10" e | 14' 10" e | 13' 0" e |

¹ Web height-to-thickness ratio exceeds 200. Web stiffeners are required at all support points and concentrated loads.
 "e" Web stiffeners required at ends.

Lateral Bracing

Example of lateral bracing at wall not sheathed at full height.

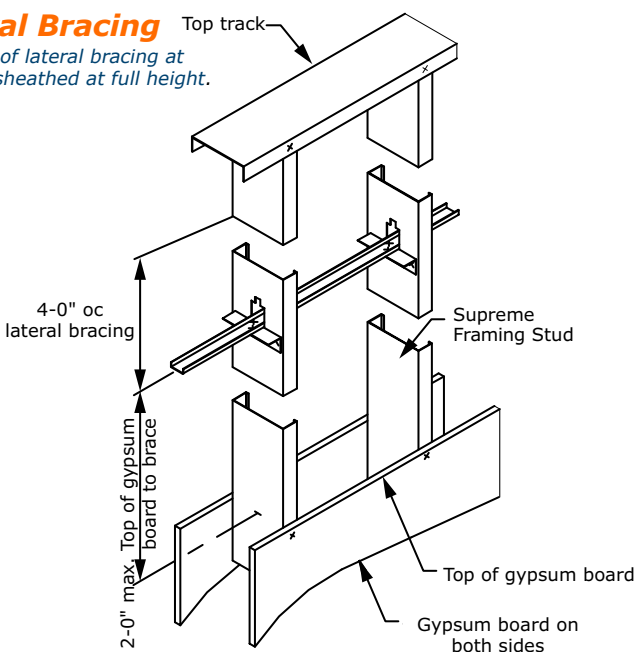

Lateral Bracing

Example of lateral bracing at wall sheathed at full height on one side.

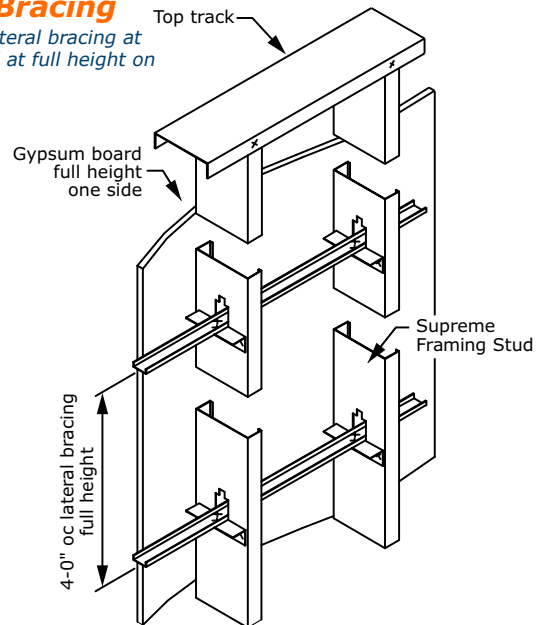

Flat Strap Lateral Bracing

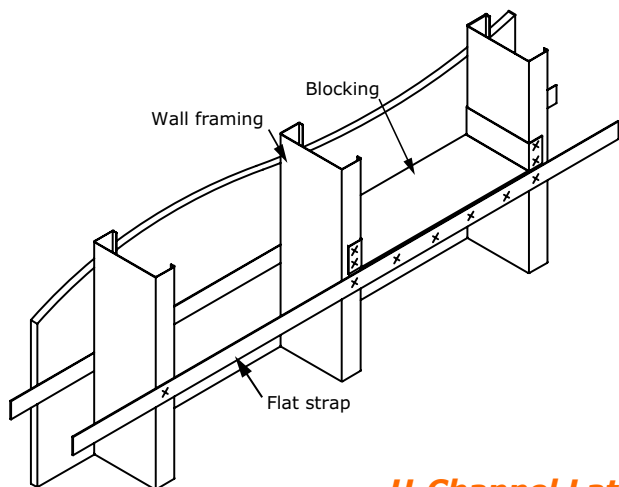

Deflection Track

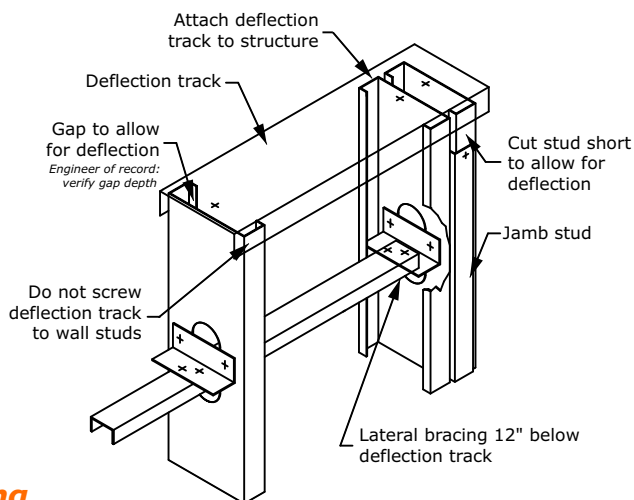

U-Channel Lateral Bracing

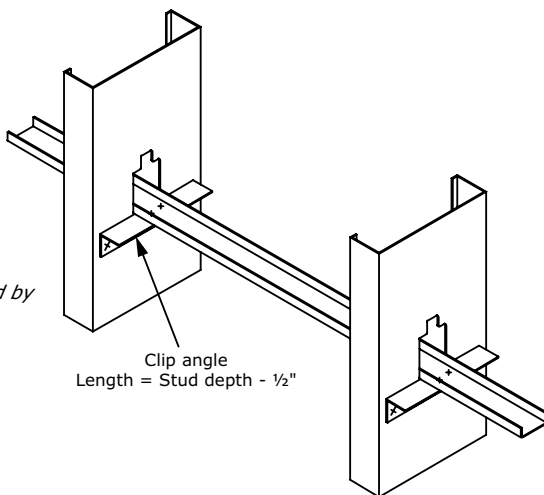

General Note:

All connections should be designed by a licensed design professional.

Curtain Wall Limiting Heights

Table Notes

- For 33EQD wall heights, refer to 30EQD values.
- Listed wind pressures represent calculated designed wind pressure (1.0 W based on 2009 IBC or 0.6 W based on 2012 IBC). For deflection calculations, listed wind pressures have been reduced by 0.70 as allowed by IBC. The 5 psf pressure has not been reduced for deflection checks.
- Studs must be braced against rotation and lateral movement at all supports. See typical bracing details on page 13.
- Studs are assumed to be adequately braced at a maximum spacing of L_u to develop full allowable moment.
- Web crippling check is based on 1" of bearing at end supports and 3" of bearing at interior support.
- Shear and web crippling capacity at end supports have **not** been reduced for punchouts. Shear and web crippling capacity at interior support have been reduced for the presence of punchout adjacent to the support.
- Combined bending and shear check at interior support is based on unreinforced web per AISI S100 (Eq. C3.3.1-1). Shear capacity and combined bending and shear check at interior support have been reduced for the presence of punchouts adjacent to support.
- See page 5 for additional table notes.

| 350 SFS | | | | | | | | | | | | | | |
|-----------------|----------|-----------------|---------|---------|---------|---------|---------|---------|---------|---------|---------|----------|---------|--------|
| Part No. | Fy (ksi) | Spacing (in) oc | 5 psf | | | 15 psf | | | 20 psf | | | 25 psf | | |
| | | | L/120 | L/240 | L/360 | L/240 | L/360 | L/600 | L/240 | L/360 | L/600 | L/240 | L/360 | L/600 |
| 350SFS162-33EQS | 57 | 12 | 22' 4" | 17' 8" | 15' 5" | 13' 10" | 12' 1" | 10' 2" | 12' 6" | 10' 11" | 9' 3" | 11' 8" | 10' 2" | 8' 7" |
| | 57 | 16 | 20' 3" | 16' 1" | 14' 0" | 12' 6" | 10' 11" | 9' 3" | 11' 5" | 9' 11" | 8' 5" | 10' 7" | 9' 3" | - |
| | 57 | 24 | 17' 8" | 14' 0" | 12' 3" | 10' 11" | 9' 7" | 8' 1" | 9' 11" | 8' 8" | - | 8' 11" e | 8' 1" | - |
| 350SFS162-43EQS | 57 | 12 | 24' 10" | 19' 8" | 17' 2" | 15' 4" | 13' 5" | 11' 4" | 13' 11" | 12' 2" | 10' 3" | 12' 11" | 11' 4" | 9' 6" |
| | 57 | 16 | 22' 6" | 17' 10" | 15' 7" | 13' 11" | 12' 2" | 10' 3" | 12' 8" | 11' 1" | 9' 4" | 11' 9" | 10' 3" | 8' 8" |
| | 57 | 24 | 19' 8" | 15' 7" | 13' 8" | 12' 2" | 10' 8" | 9' 0" | 11' 1" | 9' 8" | 8' 2" | 10' 3" | 9' 0" | - |
| 350SFS200-43EQS | 57 | 12 | 25' 9" | 20' 5" | 17' 10" | 16' 2" | 14' 1" | 11' 11" | 14' 8" | 12' 10" | 10' 10" | 13' 7" | 11' 11" | 10' 0" |
| | 57 | 16 | 23' 4" | 18' 6" | 16' 2" | 14' 8" | 12' 10" | 10' 10" | 13' 4" | 11' 8" | 9' 10" | 12' 4" | 10' 10" | 9' 1" |
| | 57 | 24 | 20' 4" | 16' 2" | 14' 2" | 12' 10" | 11' 2" | 9' 5" | 11' 8" | 10' 2" | 8' 7" | 10' 10" | 9' 5" | 8' 0" |

| Part No. | Fy (ksi) | Spacing (in) oc | 30 psf | | | 35 psf | | | 40 psf | | | 50 psf | | |
|-----------------|----------|-----------------|---------|--------|-------|---------|--------|-------|---------|--------|-------|----------|-------|-------|
| | | | L/240 | L/360 | L/600 | L/240 | L/360 | L/600 | L/240 | L/360 | L/600 | L/240 | L/360 | L/600 |
| 350SFS162-33EQS | 57 | 12 | 10' 11" | 9' 7" | 8' 1" | 10' 5" | 9' 1" | - | 9' 11" | 8' 8" | - | 8' 11" e | 8' 1" | - |
| | 57 | 16 | 9' 11" | 8' 8" | - | 9' 3" e | 8' 3" | - | 8' 8" e | - | - | - | - | - |
| | 57 | 24 | 8' 2" e | - | - | - | - | - | - | - | - | - | - | - |
| 350SFS162-43EQS | 57 | 12 | 12' 2" | 10' 8" | 9' 0" | 11' 7" | 10' 1" | 8' 6" | 11' 1" | 9' 8" | 8' 2" | 10' 3" | 9' 0" | - |
| | 57 | 16 | 11' 1" | 9' 8" | 8' 2" | 10' 6" | 9' 2" | - | 10' 1" | 8' 9" | - | 9' 4" | 8' 2" | - |
| | 57 | 24 | 9' 8" | 8' 5" | - | 9' 1" | 8' 0" | - | 8' 6" | - | - | - | - | - |
| 350SFS200-43EQS | 57 | 12 | 12' 10" | 11' 2" | 9' 5" | 12' 2" | 10' 8" | 9' 0" | 11' 8" | 10' 2" | 8' 7" | 10' 10" | 9' 5" | 8' 0" |
| | 57 | 16 | 11' 8" | 10' 2" | 8' 7" | 11' 1" | 9' 8" | 8' 2" | 10' 7" | 9' 3" | - | 9' 6" | 8' 7" | - |
| | 57 | 24 | 10' 1" | 8' 11" | - | 9' 4" | 8' 5" | - | 8' 9" | 8' 1" | - | - | - | - |

| 362 SFS | | | | | | | | | | | | | | |
|-----------------|----------|-----------------|---------|--------|---------|---------|---------|--------|---------|---------|--------|---------|--------|--------|
| Part No. | Fy (ksi) | Spacing (in) oc | 5 psf | | | 15 psf | | | 20 psf | | | 25 psf | | |
| | | | L/120 | L/240 | L/360 | L/240 | L/360 | L/600 | L/240 | L/360 | L/600 | L/240 | L/360 | L/600 |
| 362SFS162-33EQS | 57 | 12 | 22' 11" | 18' 2" | 15' 11" | 14' 2" | 12' 5" | 10' 5" | 12' 11" | 11' 3" | 9' 6" | 12' 0" | 10' 5" | 8' 10" |
| | 57 | 16 | 20' 10" | 16' 6" | 14' 5" | 12' 11" | 11' 3" | 9' 6" | 11' 8" | 10' 3" | 8' 7" | 10' 10" | 9' 6" | 8' 0" |
| | 57 | 24 | 18' 2" | 14' 5" | 12' 7" | 11' 3" | 9' 10" | 8' 3" | 10' 2" | 8' 11" | - | 9' 1" e | 8' 3" | - |
| 362SFS162-43EQS | 57 | 12 | 25' 6" | 20' 3" | 17' 8" | 15' 9" | 13' 9" | 11' 7" | 14' 4" | 12' 6" | 10' 7" | 13' 4" | 11' 7" | 9' 9" |
| | 57 | 16 | 23' 2" | 18' 4" | 16' 0" | 14' 4" | 12' 6" | 10' 7" | 13' 0" | 11' 4" | 9' 7" | 12' 1" | 10' 7" | 8' 11" |
| | 57 | 24 | 20' 3" | 16' 0" | 14' 0" | 12' 6" | 10' 11" | 9' 2" | 11' 4" | 9' 11" | 8' 4" | 10' 7" | 9' 2" | 7' 9" |
| 362SFS200-43EQS | 57 | 12 | 26' 5" | 21' 0" | 18' 4" | 16' 7" | 14' 6" | 12' 3" | 15' 1" | 13' 2" | 11' 1" | 14' 0" | 12' 3" | 10' 4" |
| | 57 | 16 | 24' 0" | 19' 1" | 16' 8" | 15' 1" | 13' 2" | 11' 1" | 13' 8" | 11' 11" | 10' 1" | 12' 8" | 11' 1" | 9' 4" |
| | 57 | 24 | 21' 0" | 16' 8" | 14' 6" | 13' 2" | 11' 6" | 9' 8" | 11' 11" | 10' 5" | 8' 10" | 11' 1" | 9' 8" | 8' 2" |

"e" Web stiffeners required at ends.

362 SFS table continues on next page

362 SFS table continued from previous page

| Part No. | Fy (ksi) | Spacing (in) oc | 30 psf | | | 35 psf | | | 40 psf | | | 50 psf | | |
|-----------------|----------|-----------------|---------|---------|--------|---------|---------|--------|----------|---------|--------|---------|--------|-------|
| | | | L/240 | L/360 | L/600 | L/240 | L/360 | L/600 | L/240 | L/360 | L/600 | L/240 | L/360 | L/600 |
| 362SFS162-33EQS | 57 | 12 | 11' 3" | 9' 10" | 8' 3" | 10' 8" | 9' 4" | - | 10' 2" | 8' 11" | - | 9' 1" e | 8' 3" | - |
| | 57 | 16 | 10' 2" | 8' 11" | - | 9' 5" e | 8' 6" | - | 8' 10" e | 8' 1" e | - | - | - | - |
| | 57 | 24 | 8' 3" e | - | - | - | - | - | - | - | - | - | - | - |
| 362SFS162-43EQS | 57 | 12 | 12' 6" | 10' 11" | 9' 2" | 11' 11" | 10' 5" | 8' 9" | 11' 4" | 9' 11" | 8' 4" | 10' 7" | 9' 2" | 7' 9" |
| | 57 | 16 | 11' 4" | 9' 11" | 8' 4" | 10' 10" | 9' 5" | 7' 11" | 10' 4" | 9' 0" | 7' 7" | 9' 6" | 8' 4" | 7' 1" |
| | 57 | 24 | 9' 11" | 8' 8" | 7' 4" | 9' 3" | 8' 3" | 6' 11" | 8' 8" | 7' 10" | 6' 8" | 7' 9" | 7' 4" | 6' 2" |
| 362SFS200-43EQS | 57 | 12 | 13' 2" | 11' 6" | 9' 8" | 12' 6" | 10' 11" | 9' 3" | 11' 11" | 10' 5" | 8' 10" | 11' 1" | 9' 8" | 8' 2" |
| | 57 | 16 | 11' 11" | 10' 5" | 8' 10" | 11' 4" | 9' 11" | 8' 4" | 10' 10" | 9' 6" | 8' 0" | 9' 9" | 8' 10" | - |
| | 57 | 24 | 10' 3" | 9' 2" | - | 9' 6" | 8' 8" | - | 8' 11" | 8' 3" | - | - | - | - |

400 SFS

| Part No. | Fy (ksi) | Spacing (in) oc | 5 psf | | | 15 psf | | | 20 psf | | | 25 psf | | |
|-----------------|----------|-----------------|---------|---------|---------|---------|---------|--------|----------|---------|---------|---------|----------|--------|
| | | | L/120 | L/240 | L/360 | L/240 | L/360 | L/600 | L/240 | L/360 | L/600 | L/240 | L/360 | L/600 |
| 400SFS162-33EQS | 57 | 12 | 24' 9" | 19' 8" | 17' 2" | 15' 4" | 13' 5" | 11' 3" | 13' 11" | 12' 2" | 10' 3" | 12' 11" | 11' 3" | 9' 6" |
| | 57 | 16 | 22' 6" | 17' 10" | 15' 7" | 13' 11" | 12' 2" | 10' 3" | 12' 8" | 11' 0" | 9' 4" | 11' 9" | 10' 3" | 8' 8" |
| | 57 | 24 | 19' 8" | 15' 7" | 13' 7" | 12' 2" | 10' 7" | 8' 11" | 10' 9" e | 9' 8" | 8' 1" | 9' 7" e | 8' 11" e | - |
| 400SFS162-43EQS | 57 | 12 | 27' 6" | 21' 10" | 19' 1" | 17' 0" | 14' 10" | 12' 6" | 15' 6" | 13' 6" | 11' 5" | 14' 4" | 12' 6" | 10' 7" |
| | 57 | 16 | 25' 0" | 19' 10" | 17' 4" | 15' 6" | 13' 6" | 11' 5" | 14' 1" | 12' 3" | 10' 4" | 13' 0" | 11' 5" | 9' 7" |
| | 57 | 24 | 21' 10" | 17' 4" | 15' 1" | 13' 6" | 11' 9" | 9' 11" | 12' 3" | 10' 9" | 9' 0" | 11' 5" | 9' 11" | 8' 5" |
| 400SFS200-43EQS | 57 | 12 | 28' 6" | 22' 7" | 19' 9" | 17' 10" | 15' 7" | 13' 2" | 16' 3" | 14' 2" | 12' 0" | 15' 1" | 13' 2" | 11' 1" |
| | 57 | 16 | 25' 11" | 20' 7" | 17' 11" | 16' 3" | 14' 2" | 12' 0" | 14' 9" | 12' 11" | 10' 10" | 13' 8" | 12' 0" | 10' 1" |
| | 57 | 24 | 22' 7" | 17' 11" | 15' 8" | 14' 2" | 12' 5" | 10' 5" | 12' 11" | 11' 3" | 9' 6" | 11' 10" | 10' 5" | 8' 10" |

| Part No. | Fy (ksi) | Spacing (in) oc | 30 psf | | | 35 psf | | | 40 psf | | | 50 psf | | |
|-----------------|----------|-----------------|----------|---------|--------|----------|---------|--------|----------|---------|-------|---------|----------|--------|
| | | | L/240 | L/360 | L/600 | L/240 | L/360 | L/600 | L/240 | L/360 | L/600 | L/240 | L/360 | L/600 |
| 400SFS162-33EQS | 57 | 12 | 12' 2" | 10' 7" | 8' 11" | 11' 6" | 10' 1" | 8' 6" | 10' 9" e | 9' 8" | 8' 1" | 9' 7" e | 8' 11" e | - |
| | 57 | 16 | 10' 9" e | 9' 8" | 8' 1" | 9' 11" e | 9' 2" e | - | 9' 3" e | 8' 9" e | - | 8' 4" e | 8' 1" e | - |
| | 57 | 24 | 8' 9" e | 8' 5" e | - | 8' 1" e | 8' 0" e | - | - | - | - | - | - | - |
| 400SFS162-43EQS | 57 | 12 | 13' 6" | 11' 9" | 9' 11" | 12' 10" | 11' 2" | 9' 5" | 12' 3" | 10' 9" | 9' 0" | 11' 5" | 9' 11" | 8' 5" |
| | 57 | 16 | 12' 3" | 10' 9" | 9' 0" | 11' 8" | 10' 2" | 8' 7" | 11' 2" | 9' 9" | 8' 2" | 10' 1" | 9' 0" | 7' 7" |
| | 57 | 24 | 10' 7" | 9' 4" | 7' 11" | 9' 10" | 8' 11" | 7' 6" | 9' 2" | 8' 6" | 7' 2" | 8' 2" e | 7' 11" e | 6' 8" |
| 400SFS200-43EQS | 57 | 12 | 14' 2" | 12' 5" | 10' 5" | 13' 6" | 11' 9" | 9' 11" | 12' 11" | 11' 3" | 9' 6" | 11' 10" | 10' 5" | 8' 10" |
| | 57 | 16 | 12' 11" | 11' 3" | 9' 6" | 12' 3" | 10' 8" | 9' 0" | 11' 6" | 10' 3" | 8' 8" | 10' 3" | 9' 6" | 8' 0" |
| | 57 | 24 | 10' 10" | 9' 10" | 8' 4" | 10' 0" | 9' 4" | - | 9' 4" | 8' 11" | - | 8' 5" e | 8' 4" e | - |

550 SFS

| Part No. | Fy (ksi) | Spacing (in) o.c. | 5 psf | | | 15 psf | | | 20 psf | | | 25 psf | | |
|-----------------|----------|-------------------|---------|---------|--------|----------|----------|---------|----------|----------|----------|-----------|----------|---------|
| | | | L/120 | L/240 | L/360 | L/240 | L/360 | L/600 | L/240 | L/360 | L/600 | L/240 | L/360 | L/600 |
| 550SFS162-33EQS | 57 | 12 | 31' 10" | 25' 3" | 22' 1" | 19' 9" | 17' 3" | 14' 6" | 17' 11" | 15' 8" | 13' 2" | 16' 1" e | 14' 6" | 12' 3" |
| | 57 | 16 | 28' 11" | 22' 11" | 20' 0" | 17' 11" | 15' 8" | 13' 2" | 15' 7" e | 14' 2" | 12' 0" | 13' 11" e | 13' 2" e | 11' 1" |
| | 57 | 24 | 25' 3" | 20' 0" | 17' 6" | 14' 8" e | 13' 8" e | 11' 6" | 12' 8" e | 12' 5" e | 10' 5" e | 11' 4" e | 11' 4" e | 9' 8" e |
| 550SFS162-43EQS | 57 | 12 | 35' 3" | 28' 0" | 24' 5" | 21' 10" | 19' 1" | 16' 1" | 19' 10" | 17' 4" | 14' 7" | 18' 5" | 16' 1" | 13' 7" |
| | 57 | 16 | 32' 0" | 25' 5" | 22' 2" | 19' 10" | 17' 4" | 14' 7" | 18' 0" | 15' 9" | 13' 3" | 16' 9" | 14' 7" | 12' 4" |
| | 57 | 24 | 28' 0" | 22' 2" | 19' 5" | 17' 4" | 15' 2" | 12' 9" | 15' 9" | 13' 9" | 11' 7" | 14' 1" | 12' 9" | 10' 9" |
| 550SFS200-43EQS | 57 | 12 | 26' 6" | 29' 0" | 25' 4" | 22' 10" | 19' 11" | 16' 10" | 20' 9" | 18' 1" | 15' 3" | 19' 3" | 16' 10" | 14' 2" |
| | 57 | 16 | 33' 2" | 26' 4" | 23' 0" | 20' 9" | 18' 1" | 15' 3" | 18' 10" | 16' 5" | 13' 11" | 17' 6" | 15' 3" | 12' 11" |
| | 57 | 24 | 29' 0" | 23' 0" | 20' 1" | 18' 1" | 15' 10" | 13' 4" | 16' 1" | 14' 4" | 12' 1" | 14' 5" e | 13' 4" | 11' 3" |

"e" Web stiffeners required at ends.

550 SFS table continued on next page

550 SFS table continued

| Part No. | Fy (ksi) | Spacing (in) oc | 30 psf | | | 35 psf | | | 40 psf | | | 50 psf | | |
|-----------------|----------|-----------------|-----------|----------|----------|-----------|-----------|----------|-----------|-----------|----------|----------|----------|----------|
| | | | L/240 | L/360 | L/600 | L/240 | L/360 | L/600 | L/240 | L/360 | L/600 | L/240 | L/360 | L/600 |
| 550SFS162-33EQS | 57 | 12 | 14' 8" e | 13' 8" e | 11' 6" | 13' 7" e | 13' 0" e | 10' 11" | 12' 8" e | 12' 5" e | 10' 5" e | 11' 4" e | 11' 4" e | 9' 8" e |
| | 57 | 16 | 12' 8" e | 12' 5" e | 10' 5" e | 11' 9" e | 11' 9" e | 9' 11" e | 11' 0" e | 11' 0" e | 9' 6" e | 9' 10" e | 9' 10" e | 8' 10" e |
| | 57 | 24 | 10' 4" e | 10' 4" e | 9' 2" e | 9' 7" e | 9' 7" e | 8' 8" e | 9' 0" e | 9' 0" e | 8' 3" e | 8' 0" e | 8' 0" e | - |
| 550SFS162-43EQS | 57 | 12 | 17' 4" | 15' 2" | 12' 9" | 16' 6" | 14' 4" | 12' 1" | 15' 9" | 13' 9" | 11' 7" | 14' 1" | 12' 9" | 10' 9" |
| | 57 | 16 | 15' 9" | 13' 9" | 11' 7" | 14' 7" | 13' 1" | 11' 0" | 13' 8" e | 12' 6" | 10' 6" | 12' 2" e | 11' 7" e | 9' 9" |
| | 57 | 24 | 12' 10" e | 12' 0" e | 10' 1" | 11' 11" e | 11' 5" e | 9' 7" | 11' 1" e | 10' 11" e | 9' 2" e | 9' 11" e | 9' 11" e | 8' 6" e |
| 550SFS200-43EQS | 57 | 12 | 18' 1" | 15' 10" | 13' 4" | 17' 2" | 15' 0" | 12' 8" | 16' 1" | 14' 4" | 12' 1" | 14' 5" e | 13' 4" | 11' 3" |
| | 57 | 16 | 16' 1" | 14' 4" | 12' 1" | 14' 11" | 13' 8" | 11' 6" | 13' 11" e | 13' 1" | 11' 0" | 12' 6" e | 12' 1" e | 10' 3" |
| | 57 | 24 | 13' 2" e | 12' 7" e | 10' 7" | 12' 2" e | 11' 11" e | 10' 1" | 11' 4" e | 11' 4" e | 9' 7" e | 10' 2" e | 10' 2" e | 8' 11" e |

600 SFS

| Part No. | Fy (ksi) | Spacing (in) oc | 5 psf | | | 15 psf | | | 20 psf | | | 25 psf | | |
|-----------------|----------|-----------------|--------|--------|--------|----------|----------|--------|----------|----------|----------|-----------|-----------|-----------|
| | | | L/120 | L/240 | L/360 | L/240 | L/360 | L/600 | L/240 | L/360 | L/600 | L/240 | L/360 | L/600 |
| 600SFS162-33EQS | 57 | 12 | 34' 2" | 27' 1" | 23' 8" | 21' 2" | 18' 6" | 15' 7" | 18' 9" | 16' 9" | 14' 2" | 16' 9" e | 15' 7" e | 13' 1" |
| | 57 | 16 | 31' 0" | 24' 7" | 21' 6" | 18' 9" | 16' 9" | 14' 2" | 16' 3" e | 15' 3" e | 12' 10" | 14' 6" e | 14' 2" e | 11' 11" e |
| | 57 | 24 | 26' 7" | 21' 6" | 18' 9" | 15' 4" e | 14' 8" e | 12' 4" | 13' 3" e | 13' 3" e | 11' 3" e | 11' 10" e | 11' 10" e | 10' 5" e |
| 600SFS162-43EQS | 57 | 12 | 37' 9" | 30' 0" | 26' 2" | 23' 5" | 20' 5" | 17' 3" | 21' 3" | 18' 7" | 15' 8" | 19' 9" | 17' 3" | 14' 6" |
| | 57 | 16 | 34' 4" | 27' 3" | 23' 9" | 21' 3" | 18' 7" | 15' 8" | 19' 4" | 16' 10" | 14' 3" | 17' 11" | 15' 8" | 13' 2" |
| | 57 | 24 | 30' 0" | 23' 9" | 20' 9" | 18' 7" | 16' 3" | 13' 8" | 16' 6" | 14' 9" | 12' 5" | 14' 9" e | 13' 8" | 11' 6" |
| 600SFS200-43EQS | 57 | 12 | 39' 2" | 31' 1" | 27' 2" | 24' 5" | 21' 4" | 18' 0" | 22' 2" | 19' 5" | 16' 4" | 20' 7" | 18' 0" | 15' 2" |
| | 57 | 16 | 35' 7" | 28' 3" | 24' 8" | 22' 2" | 19' 5" | 16' 4" | 20' 2" | 17' 7" | 14' 10" | 18' 5" | 16' 4" | 13' 9" |
| | 57 | 24 | 31' 1" | 24' 8" | 21' 7" | 19' 5" | 16' 11" | 14' 3" | 16' 10" | 15' 5" | 13' 0" | 15' 1" e | 14' 3" e | 12' 1" |

| Part No. | Fy (ksi) | Spacing (in) oc | 30 psf | | | 35 psf | | | 40 psf | | | 50 psf | | |
|-----------------|----------|-----------------|-----------|-----------|----------|----------|-----------|----------|-----------|-----------|----------|-----------|-----------|-----------|
| | | | L/240 | L/360 | L/600 | L/240 | L/360 | L/600 | L/240 | L/360 | L/600 | L/240 | L/360 | L/600 |
| 600SFS162-33EQS | 57 | 12 | 15' 4" e | 14' 8" e | 12' 4" | 14' 2" e | 13' 11" e | 11' 9" e | 13' 3" e | 13' 3" e | 11' 3" e | 11' 10" e | 11' 10" e | 10' 5" e |
| | 57 | 16 | 13' 3" e | 13' 3" e | 11' 3" e | 12' 3" e | 12' 3" e | 10' 8" e | 11' 6" e | 11' 6" e | 10' 2" e | 10' 3" e | 10' 3" e | 9' 5" e |
| | 57 | 24 | 10' 10" e | 10' 10" e | 9' 9" e | 10' 0" e | 10' 0" e | 9' 4" e | 9' 4" e | 9' 4" e | 8' 11" e | - | - | - |
| 600SFS162-43EQS | 57 | 12 | 18' 7" | 16' 3" | 13' 8" | 17' 7" | 15' 5" | 13' 0" | 16' 6" | 14' 9" | 12' 5" | 14' 9" e | 13' 8" | 11' 6" |
| | 57 | 16 | 16' 6" | 14' 9" | 12' 5" | 15' 3" e | 14' 0" | 11' 10" | 14' 3" e | 13' 5" e | 11' 3" | 12' 9" e | 12' 5" e | 10' 6" |
| | 57 | 24 | 13' 5" e | 12' 10" e | 10' 10" | 12' 5" e | 12' 3" e | 10' 4" e | 11' 8" e | 11' 8" e | 9' 10" e | 10' 5" e | 10' 5" e | 9' 2" e |
| 600SFS200-43EQS | 57 | 12 | 19' 5" | 16' 11" | 14' 3" | 18' 0" | 16' 1" | 13' 7" | 16' 10" | 15' 5" | 13' 0" | 15' 1" e | 14' 3" e | 12' 1" |
| | 57 | 16 | 16' 10" | 15' 5" | 13' 0" | 15' 7" e | 14' 7" | 12' 4" | 14' 7" e | 14' 0" e | 11' 9" | 13' 1" e | 13' 0" e | 10' 11" e |
| | 57 | 24 | 13' 9" e | 13' 5" e | 11' 4" | 12' 9" e | 12' 9" e | 10' 9" e | 11' 11" e | 11' 11" e | 10' 4" e | 10' 8" e | 10' 8" e | 9' 7" e |

800 SFS

| Part No. | Fy (ksi) | Spacing (in) oc | 5 psf | | | 15 psf | | | 20 psf | | | 25 psf | | |
|-----------------|----------|-----------------|---------|--------|--------|----------|--------|---------|----------|----------|--------|-----------|-----------|----------|
| | | | L/120 | L/240 | L/360 | L/240 | L/360 | L/600 | L/240 | L/360 | L/600 | L/240 | L/360 | L/600 |
| 800SFS162-43EQS | 57 | 12 | 46' 9" | 37' 1" | 32' 5" | 28' 11" | 25' 3" | 21' 4" | 26' 3" | 23' 0" | 19' 4" | 24' 0" | 21' 4" | 18' 0" |
| | 57 | 16 | 42' 5" | 33' 8" | 29' 5" | 26' 3" | 23' 0" | 19' 4" | 23' 3" | 20' 10" | 17' 7" | 20' 9" e | 19' 4" | 16' 4" |
| | 57 | 24 | 37' 1" | 29' 5" | 25' 8" | 21' 11" | 20' 1" | 16' 11" | 19' 0" e | 18' 3" e | 15' 4" | 16' 11" e | 16' 11" e | 14' 3" e |
| 800SFS200-43EQS | 57 | 12 | 49' 5" | 39' 2" | 34' 3" | 30' 8" | 26' 9" | 22' 7" | 27' 6" | 24' 4" | 20' 6" | 24' 7" | 22' 7" | 19' 0" |
| | 57 | 16 | 44' 10" | 35' 7" | 31' 1" | 27' 6" | 24' 4" | 20' 6" | 23' 10" | 22' 1" | 18' 8" | 21' 4" e | 20' 6" e | 17' 4" |
| | 57 | 24 | 38' 11" | 31' 1" | 27' 2" | 22' 6" e | 21' 3" | 17' 11" | 19' 6" e | 19' 4" e | 16' 3" | 17' 5" e | 17' 5" e | 15' 1" e |

| Part No. | Fy (ksi) | Spacing (in) oc | 30 psf | | | 35 psf | | | 40 psf | | | 50 psf | | |
|-----------------|----------|-----------------|-----------|-----------|----------|-----------|----------|----------|-----------|-----------|-----------|-----------|-----------|-----------|
| | | | L/240 | L/360 | L/600 | L/240 | L/360 | L/600 | L/240 | L/360 | L/600 | L/240 | L/360 | L/600 |
| 800SFS162-43EQS | 57 | 12 | 21' 11" | 20' 1" | 16' 11" | 20' 3" e | 19' 1" | 16' 1" | 19' 0" e | 18' 3" e | 15' 4" | 16' 11" e | 16' 11" e | 14' 3" e |
| | 57 | 16 | 19' 0" e | 18' 3" e | 15' 4" | 17' 7" e | 17' 4" e | 14' 7" e | 16' 5" e | 16' 5" e | 13' 11" e | 14' 8" e | 14' 8" e | 12' 11" e |
| | 57 | 24 | 15' 6" e | 15' 6" e | 13' 5" e | 14' 4" e | 14' 4" e | 12' 9" e | 13' 5" e | 13' 5" e | 12' 2" e | 12' 0" e | 12' 0" e | 11' 4" e |
| 800SFS200-43EQS | 57 | 12 | 22' 6" e | 21' 3" | 17' 11" | 20' 10" e | 20' 2" e | 17' 0" | 19' 6" e | 19' 4" e | 16' 3" | 17' 5" e | 17' 5" e | 15' 1" e |
| | 57 | 16 | 19' 6" e | 19' 4" e | 16' 3" | 18' 0" e | 18' 0" e | 15' 6" e | 16' 10" e | 16' 10" e | 14' 9" e | 15' 1" e | 15' 1" e | 13' 9" e |
| | 57 | 24 | 15' 11" e | 15' 11" e | 14' 3" e | 14' 9" e | 14' 9" e | 13' 6" e | 13' 9" e | 13' 9" e | 12' 11" e | 12' 4" e | 12' 4" e | 12' 0" e |

"e" Web stiffeners required at ends.
See Table Notes on page 10

Combined Axial and Lateral Loads

Table Notes

- For 33EQD loads, refer to 30EQD values.
- Allowable axial loads listed in kips (1 kip = 1000 pounds).
- Allowable axial loads listed are based on simple single span condition.
- Allowable axial load determined in accordance with AISI S100 Section C5 and with the assumption that axial load passes through centroid of the effective section.
- Allowable axial loads are based on 4'-0" on center bracing.
- Studs are assumed to be adequately braced at a maximum of spacing of L_u to develop full allowable moment, M_a .
- Listed wind pressures represent calculated designed wind pressure (1.0 W based on 2009 IBC or 0.6 W based on 2012 IBC). For deflection calculations, listed wind pressures have been reduced by 0.70 as allowed by IBC. The 5 psf pressure has not been reduced for deflection checks.
- Ends supports have not been checked for web crippling. See web crippling tables on page 20.
- See page 5 for additional table notes.

| 5 psf | | | | | | | | | | |
|------------------|------------------------|-------------------|-------------------|-------------------|-------------------|-------------------|-------|-----------------|-----------------|-----------------|
| Wall Height (ft) | Spacing (in) on center | 362SFS162-(mil) | | 400SFS162-(mil) | | 600SFS162-(mil) | | 600SFS200-(mil) | 800SFS162-(mil) | 800SFS200-(mil) |
| | | 33EQS | 43EQS | 33EQS | 43EQS | 33EQS | 43EQS | 43EQS | 43EQS | 43EQS |
| 8 | 12 | 1.79 | 2.74 | 1.98 | 3.07 | 2.43 | 3.85 | 4.14 | 3.71 | 4.29 |
| | 16 | 1.73 | 2.68 | 1.92 | 3.01 | 2.39 | 3.81 | 4.09 | 3.68 | 4.26 |
| | 24 | 1.61 | 2.55 | 1.80 | 2.88 | 2.30 | 3.73 | 4.00 | 3.62 | 4.19 |
| 9 | 12 | 1.65 | 2.52 | 1.85 | 2.87 | 2.39 | 3.82 | 4.06 | 3.69 | 4.26 |
| | 16 | 1.57 | 2.44 | 1.77 | 2.79 | 2.34 | 3.76 | 4.00 | 3.65 | 4.22 |
| | 24 | 1.42 | 2.28 | 1.63 | 2.63 | 2.23 | 3.65 | 3.89 | 3.57 | 4.14 |
| 10 | 12 | 1.48 | 2.27 | 1.70 | 2.65 | 2.34 | 3.77 | 3.96 | 3.66 | 4.23 |
| | 16 | 1.39 | 2.17 | 1.61 | 2.55 | 2.28 | 3.70 | 3.89 | 3.61 | 4.18 |
| | 24 | 1.22 | 1.99 | 1.44 | 2.36 | 2.14 | 3.55 | 3.75 | 3.52 | 4.08 |
| 12 | 12 | 1.15 | 1.78 | 1.37 | 2.14 | 2.17 | 3.54 | 3.71 | 3.59 | 4.15 |
| | 16 | 1.04 ³ | 1.67 | 1.26 | 2.02 | 2.07 | 3.43 | 3.61 | 3.52 | 4.08 |
| | 24 | 0.84 ⁴ | 1.45 ⁴ | 1.05 ⁴ | 1.79 | 1.88 | 3.23 | 3.40 | 3.38 | 3.92 |
| 14 | 12 | 0.85 ⁴ | 1.36 | 1.05 ⁵ | 1.68 | 1.94 | 3.19 | 3.39 | 3.50 | 4.02 |
| | 16 | 0.73 ⁴ | 1.24 ⁴ | 0.93 ⁴ | 1.54 ⁵ | 1.81 | 3.05 | 3.25 | 3.40 | 3.91 |
| | 24 | 0.53 ³ | 1.01 ⁴ | 0.71 ³ | 1.30 ⁴ | 1.57 | 2.79 | 2.98 | 3.20 | 3.69 |
| 16 | 12 | 0.61 ³ | 1.03 ⁴ | 0.78 ⁴ | 1.29 ⁵ | 1.67 | 2.78 | 3.01 | 3.39 | 3.79 |
| | 16 | 0.50 ³ | 0.90 ⁴ | 0.65 ³ | 1.15 ⁴ | 1.52 | 2.61 | 2.83 | 3.25 | 3.65 |
| | 24 | 0.30 ² | 0.68 ³ | 0.43 ² | 0.90 ³ | 1.23 ⁴ | 2.29 | 2.51 | 2.99 | 3.37 |

| 15 psf | | | | | | | | | | |
|------------------|------------------------|-------------------|-------------------|-------------------|-------------------|-------------------|-------------------|-------------------|-------------------|-----------------|
| Wall Height (ft) | Spacing (in) on center | 362SFS162-(mil) | | 400SFS162-(mil) | | 600SFS162-(mil) | | 600SFS200-(mil) | 800SFS162-(mil) | 800SFS200-(mil) |
| | | 33EQS | 43EQS | 33EQS | 43EQS | 33EQS | 43EQS | 43EQS | 43EQS | 43EQS |
| 8 | 12 | 1.43 | 2.36 | 1.63 | 2.70 | 2.18 | 3.60 | 3.87 | 3.54 | 4.10 |
| | 16 | 1.27 | 2.18 | 1.47 | 2.52 | 2.05 | 3.47 | 3.74 | 3.45 | 4.00 |
| | 24 | 0.95 ⁵ | 1.83 | 1.16 | 2.17 | 1.81 | 3.22 | 3.48 | 3.27 | 3.81 |
| 9 | 12 | 1.21 | 2.05 | 1.42 | 2.41 | 2.07 | 3.48 | 3.72 | 3.46 | 4.01 |
| | 16 | 1.02 ⁵ | 1.84 | 1.23 | 2.19 | 1.91 | 3.32 | 3.55 | 3.35 | 3.89 |
| | 24 | 0.66 ⁴ | 1.45 ⁵ | 0.86 ⁴ | 1.79 | 1.61 | 2.99 | 3.22 | 3.12 | 3.64 |
| 10 | 12 | 0.99 ⁵ | 1.74 | 1.20 | 2.10 | 1.94 | 3.35 | 3.54 | 3.38 | 3.92 |
| | 16 | 0.78 ⁴ | 1.50 ⁵ | 0.98 ⁵ | 1.86 | 1.75 | 3.14 | 3.33 | 3.24 | 3.77 |
| | 24 | 0.39 ³ | 1.08 ⁴ | 0.58 ⁴ | 1.41 ⁴ | 1.38 | 2.74 | 2.93 | 2.96 | 3.46 |
| 12 | 12 | 0.59 ⁴ | 1.17 ⁴ | 0.78 ⁴ | 1.49 ⁵ | 1.60 | 2.93 | 3.11 | 3.17 | 3.69 |
| | 16 | 0.36 ³ | 0.92 ⁴ | 0.53 ⁴ | 1.21 ⁴ | 1.34 | 2.65 | 2.82 | 2.97 | 3.47 |
| | 24 | - | 0.47 ³ | 0.09 ³ | 0.72 ³ | 0.85 ⁵ | 2.11 | 2.28 | 2.57 | 3.02 |
| 14 | 12 | 0.28 ³ | 0.73 ³ | 0.42 ³ | 0.97 ⁴ | 1.22 | 2.41 | 2.60 | 2.92 | 3.38 |
| | 16 | 0.05 ² | 0.48 ³ | 0.17 ² | 0.69 ³ | 0.90 ⁵ | 2.06 | 2.24 | 2.64 | 3.07 |
| | 24 | - | 0.04 ² | - | 0.20 ² | 0.32 ⁴ | 1.41 ⁴ | 1.58 ⁵ | 2.10 | 2.49 |
| 16 | 12 | 0.06 ² | 0.40 ² | 0.15 ² | 0.59 ³ | 0.84 ⁴ | 1.86 | 2.06 | 2.62 | 2.97 |
| | 16 | - | 0.16 ² | - | 0.31 ² | 0.49 ⁴ | 1.47 ⁴ | 1.65 ⁵ | 2.26 | 2.59 |
| | 24 | - | - | - | - | - | 0.77 ⁴ | 0.92 ⁴ | 1.59 ⁵ | 1.87 |

If no note, deflection is less than L/720.

¹Deflection exceeds L/120

²Deflection exceeds L/240

³Deflection exceeds L/360

⁴Deflection exceeds L/600

⁵Deflection exceeds L/720

Combined Axial and Lateral Loads continued on next page

Combined Axial and Lateral Loads

Combined Axial and Lateral Loads continued

| 20 psf | | | | | | | | | | |
|------------------|------------------------|---------------------------|-------------------|---------------------------|-------------------|---------------------------|-------------------|---------------------------|---------------------------|---------------------------|
| Wall Height (ft) | Spacing (in) on center | 362SFS162-(mil) 57 ksi | | 400SFS162-(mil) 57 ksi | | 600SFS162-(mil) 57 ksi | | 600SFS200-(mil) 57 ksi | 800SFS162-(mil) 57 ksi | 800SFS200-(mil) 57 ksi |
| | | 33EQS | 43EQS | 33EQS | 43EQS | 33EQS | 43EQS | 43EQS | 43EQS | 43EQS |
| 8 | 12 | 1.27 | 2.18 | 1.47 | 2.52 | 2.05 | 3.47 | 3.74 | 3.45 | 4.00 |
| | 16 | 1.06 | 1.95 | 1.26 | 2.29 | 1.89 | 3.30 | 3.57 | 3.33 | 3.87 |
| | 24 | 0.66 ⁴ | 1.51 ⁵ | 0.86 ⁵ | 1.85 | 1.57 | 2.97 | 3.23 | 3.10 | 3.61 |
| 9 | 12 | 1.02 ⁵ | 1.84 | 1.23 | 2.19 | 1.91 | 3.32 | 3.55 | 3.35 | 3.89 |
| | 16 | 0.78 ⁴ | 1.58 | 0.98 ⁵ | 1.92 | 1.71 | 3.10 | 3.33 | 3.20 | 3.73 |
| | 24 | 0.34 ³ | 1.09 ⁴ | 0.53 ⁴ | 1.41 ⁵ | 1.31 | 2.68 | 2.90 | 2.90 | 3.40 |
| 10 | 12 | 0.78 ⁴ | 1.50 ⁵ | 0.98 ⁵ | 1.86 | 1.75 | 3.14 | 3.33 | 3.24 | 3.77 |
| | 16 | 0.52 ⁴ | 1.22 ⁴ | 0.71 ⁴ | 1.55 ⁵ | 1.50 | 2.87 | 3.06 | 3.05 | 3.56 |
| | 24 | 0.05 ³ | 0.70 ³ | 0.21 ³ | 0.99 ⁴ | 1.02 | 2.36 | 2.55 | 2.68 | 3.16 |
| 12 | 12 | 0.36 ³ | 0.92 ⁴ | 0.53 ⁴ | 1.21 ⁴ | 1.34 | 2.65 | 2.82 | 2.97 | 3.47 |
| | 16 | 0.09 ² | 0.61 ³ | 0.23 ³ | 0.87 ⁴ | 1.01 | 2.28 | 2.45 | 2.70 | 3.17 |
| | 24 | - | 0.08 ² | - | 0.28 ³ | 0.39 ⁴ | 1.60 ⁵ | 1.76 | 2.18 | 2.59 |
| 14 | 12 | 0.05 ² | 0.48 ³ | 0.17 ² | 0.69 ³ | 0.90 ⁵ | 2.06 | 2.24 | 2.64 | 3.07 |
| | 16 | - | 0.18 ² | - | 0.36 ³ | 0.51 ⁴ | 1.62 ⁵ | 1.79 ⁵ | 2.28 | 2.68 |
| | 24 | - | - | - | - | - | 0.83 ⁴ | 0.98 ⁴ | 1.59 | 1.92 |
| 16 | 12 | - | 0.16 ² | - | 0.31 ² | 0.49 ⁴ | 1.47 ⁴ | 1.65 ⁵ | 2.26 | 2.59 |
| | 16 | - | - | - | - | 0.06 ³ | 0.99 ⁴ | 1.15 ⁴ | 1.81 | 2.10 |
| | 24 | - | - | - | - | - | 0.15 ³ | 0.26 ³ | 0.96 ⁴ | 1.19 ⁵ |

| 25 psf | | | | | | | | | | |
|------------------|------------------------|---------------------------|-------------------|---------------------------|-------------------|---------------------------|-------------------|---------------------------|---------------------------|---------------------------|
| Wall Height (ft) | Spacing (in) on center | 362SFS162-(mil) 57 ksi | | 400SFS162-(mil) 57 ksi | | 600SFS162-(mil) 57 ksi | | 600SFS200-(mil) 57 ksi | 800SFS162-(mil) 57 ksi | 800SFS200-(mil) 57 ksi |
| | | 33EQS | 43EQS | 33EQS | 43EQS | 33EQS | 43EQS | 43EQS | 43EQS | 43EQS |
| 8 | 12 | 1.11 | 2.00 | 1.31 | 2.34 | 1.93 | 3.34 | 3.61 | 3.36 | 3.90 |
| | 16 | 0.85 ⁵ | 1.73 | 1.06 | 2.06 | 1.73 | 3.13 | 3.40 | 3.21 | 3.74 |
| | 24 | 0.39 ⁴ | 1.21 ⁴ | 0.58 ⁴ | 1.54 ⁵ | 1.34 | 2.72 | 2.97 | 2.92 | 3.42 |
| 9 | 12 | 0.84 ⁴ | 1.64 | 1.04 ⁵ | 1.99 | 1.76 | 3.15 | 3.39 | 3.24 | 3.77 |
| | 16 | 0.55 ⁴ | 1.33 ⁴ | 0.75 ⁴ | 1.66 | 1.51 | 2.89 | 3.12 | 3.05 | 3.56 |
| | 24 | 0.04 ³ | 0.75 ⁴ | 0.21 ³ | 1.06 ⁴ | 1.02 | 2.37 | 2.59 | 2.68 | 3.16 |
| 10 | 12 | 0.58 ⁴ | 1.29 ⁴ | 0.78 ⁴ | 1.62 ⁵ | 1.56 | 2.94 | 3.13 | 3.10 | 3.61 |
| | 16 | 0.28 ³ | 0.95 ⁴ | 0.45 ⁴ | 1.26 ⁴ | 1.26 | 2.61 | 2.80 | 2.87 | 3.36 |
| | 24 | - | 0.35 ³ | - | 0.62 ³ | 0.68 ⁵ | 1.99 | 2.17 | 2.41 | 2.86 |
| 12 | 12 | 0.15 ³ | 0.69 ³ | 0.30 ³ | 0.95 ⁴ | 1.09 | 2.37 | 2.54 | 2.76 | 3.24 |
| | 16 | - | 0.34 ³ | - | 0.57 ³ | 0.69 ⁴ | 1.93 | 2.10 | 2.44 | 2.88 |
| | 24 | - | - | - | - | - | 1.13 ⁴ | 1.28 ⁴ | 1.80 | 2.17 |
| 14 | 12 | - | 0.25 ² | - | 0.44 ³ | 0.61 ⁴ | 1.73 ⁵ | 1.90 | 2.37 | 2.78 |
| | 16 | - | - | - | 0.05 ² | 0.15 ⁴ | 1.21 ⁴ | 1.37 ⁴ | 1.93 | 2.29 |
| | 24 | - | - | - | - | - | 0.29 ³ | 0.41 ⁴ | 1.10 ⁵ | 1.38 |
| 16 | 12 | - | - | - | 0.07 ² | 0.16 ³ | 1.11 ⁴ | 1.27 ⁴ | 1.92 | 2.22 |
| | 16 | - | - | - | - | - | 0.56 ³ | 0.69 ⁴ | 1.37 ⁵ | 1.64 |
| | 24 | - | - | - | - | - | - | - | 0.37 ⁴ | 0.56 ⁴ |

| 30 psf | | | | | | | | | | |
|------------------|------------------------|---------------------------|-------------------|---------------------------|-------------------|---------------------------|-------------------|---------------------------|---------------------------|---------------------------|
| Wall Height (ft) | Spacing (in) on center | 362SFS162-(mil) 57 ksi | | 400SFS162-(mil) 57 ksi | | 600SFS162-(mil) 57 ksi | | 600SFS200-(mil) 57 ksi | 800SFS162-(mil) 57 ksi | 800SFS200-(mil) 57 ksi |
| | | 33EQS | 43EQS | 33EQS | 43EQS | 33EQS | 43EQS | 43EQS | 43EQS | 43EQS |
| 8 | 12 | 0.95 ⁵ | 1.83 | 1.16 | 2.17 | 1.81 | 3.22 | 3.48 | 3.27 | 3.81 |
| | 16 | 0.66 ⁴ | 1.51 ⁵ | 0.86 ⁵ | 1.85 | 1.57 | 2.97 | 3.23 | 3.10 | 3.61 |
| | 24 | 0.13 ³ | 0.92 ⁴ | 0.31 ⁴ | 1.24 ⁴ | 1.11 | 2.48 | 2.72 | 2.75 | 3.23 |
| 9 | 12 | 0.66 ⁴ | 1.45 ⁵ | 0.86 ⁴ | 1.79 | 1.61 | 2.99 | 3.22 | 3.12 | 3.64 |
| | 16 | 0.34 ³ | 1.09 ⁴ | 0.53 ⁴ | 1.41 ⁵ | 1.31 | 2.68 | 2.90 | 2.90 | 3.40 |
| | 24 | - | 0.44 ³ | - | 0.73 ⁴ | 0.74 | 2.07 | 2.28 | 2.46 | 2.92 |
| 10 | 12 | 0.39 ³ | 1.08 ⁴ | 0.58 ⁴ | 1.41 ⁴ | 1.38 | 2.74 | 2.93 | 2.96 | 3.46 |
| | 16 | 0.05 ³ | 0.70 ³ | 0.21 ³ | 0.99 ⁴ | 1.02 | 2.36 | 2.55 | 2.68 | 3.16 |
| | 24 | - | 0.03 ² | - | 0.26 ³ | 0.34 ⁴ | 1.63 | 1.80 | 2.15 | 2.56 |
| 12 | 12 | - | 0.47 ³ | 0.09 ³ | 0.72 ³ | 0.85 ⁵ | 2.11 | 2.28 | 2.57 | 3.02 |
| | 16 | - | 0.08 ² | - | 0.28 ³ | 0.39 ⁴ | 1.60 ⁵ | 1.76 | 2.18 | 2.59 |
| | 24 | - | - | - | - | - | 0.67 ⁴ | 0.82 ⁴ | 1.42 | 1.76 |
| 14 | 12 | - | 0.04 ² | - | 0.20 ² | 0.32 ⁴ | 1.41 ⁴ | 1.58 ⁵ | 2.10 | 2.49 |
| | 16 | - | - | - | - | - | 0.83 ⁴ | 0.98 ⁴ | 1.59 | 1.92 |
| | 24 | - | - | - | - | - | - | - | 0.62 ⁴ | 0.86 ⁵ |
| 16 | 12 | - | - | - | - | - | 0.77 ⁴ | 0.92 ⁴ | 1.59 ⁵ | 1.87 |
| | 16 | - | - | - | - | - | 0.15 ³ | 0.26 ³ | 0.96 ⁴ | 1.19 ⁵ |
| | 24 | - | - | - | - | - | - | - | - | - |

If no note, deflection is less than L/720.

¹Deflection exceeds L/120

²Deflection exceeds L/240

³Deflection exceeds L/360

⁴Deflection exceeds L/600

⁵Deflection exceeds L/720

See Table Notes on page 13

| 35 psf | | | | | | | | | | |
|------------------|------------------------|---------------------------|-------------------|---------------------------|-------------------|---------------------------|-------------------|---------------------------|---------------------------|---------------------------|
| Wall Height (ft) | Spacing (in) on center | 362SFS162-(mil) 57 ksi | | 400SFS162-(mil) 57 ksi | | 600SFS162-(mil) 57 ksi | | 600SFS200-(mil) 57 ksi | 800SFS162-(mil) 57 ksi | 800SFS200-(mil) 57 ksi |
| | | 33EQS | 43EQS | 33EQS | 43EQS | 33EQS | 43EQS | 43EQS | 43EQS | 43EQS |
| 8 | 12 | 0.80 ⁴ | 1.67 | 1.01 | 2.01 | 1.69 | 3.09 | 3.35 | 3.18 | 3.71 |
| | 16 | 0.48 ⁴ | 1.31 ⁴ | 0.67 ⁴ | 1.64 | 1.42 | 2.80 | 3.06 | 2.98 | 3.49 |
| | 24 | - | 0.64 ⁴ | 0.06 ⁴ | 0.95 ⁴ | 0.88 | 2.24 | 2.48 | 2.58 | 3.04 |
| 9 | 12 | 0.50 ⁴ | 1.27 ⁴ | 0.69 ⁴ | 1.60 ⁵ | 1.46 | 2.84 | 3.06 | 3.01 | 3.52 |
| | 16 | 0.14 ³ | 0.86 ⁴ | 0.32 ⁴ | 1.18 ⁴ | 1.11 | 2.48 | 2.69 | 2.76 | 3.24 |
| | 24 | - | 0.15 ³ | - | 0.41 ³ | 0.46 ⁵ | 1.78 | 1.98 | 2.25 | 2.68 |
| 10 | 12 | 0.22 ³ | 0.88 ⁴ | 0.39 ⁴ | 1.20 ⁴ | 1.20 | 2.55 | 2.74 | 2.82 | 3.31 |
| | 16 | - | 0.46 ³ | - | 0.74 ⁴ | 0.79 | 2.11 | 2.29 | 2.50 | 2.96 |
| | 24 | - | - | - | - | 0.02 ⁴ | 1.28 ⁵ | 1.45 | 1.88 | 2.27 |
| 12 | 12 | - | 0.27 ² | - | 0.49 ³ | 0.62 ⁴ | 1.85 | 2.02 | 2.37 | 2.81 |
| | 16 | - | - | - | 0.02 ² | 0.11 ⁴ | 1.28 ⁴ | 1.44 ⁵ | 1.92 | 2.31 |
| | 24 | - | - | - | - | - | 0.24 ⁴ | 0.37 ⁴ | 1.06 ⁵ | 1.36 |
| 14 | 12 | - | - | - | - | 0.06 ³ | 1.12 ⁴ | 1.27 ⁴ | 1.84 | 2.20 |
| | 16 | - | - | - | - | - | 0.47 ⁴ | 0.60 ⁴ | 1.26 ⁵ | 1.56 |
| | 24 | - | - | - | - | - | - | - | 0.17 ⁴ | 0.36 ⁴ |
| 16 | 12 | - | - | - | - | - | 0.45 ³ | 0.58 ³ | 1.27 ⁵ | 1.52 ⁵ |
| | 16 | - | - | - | - | - | - | - | 0.56 ⁴ | 0.76 ⁴ |
| | 24 | - | - | - | - | - | - | - | - | - |

| 40 psf | | | | | | | | | | |
|------------------|------------------------|---------------------------|-------------------|---------------------------|-------------------|---------------------------|-------------------|---------------------------|---------------------------|---------------------------|
| Wall Height (ft) | Spacing (in) on center | 362SFS162-(mil) 57 ksi | | 400SFS162-(mil) 57 ksi | | 600SFS162-(mil) 57 ksi | | 600SFS200-(mil) 57 ksi | 800SFS162-(mil) 57 ksi | 800SFS200-(mil) 57 ksi |
| | | 33EQS | 43EQS | 33EQS | 43EQS | 33EQS | 43EQS | 43EQS | 43EQS | 43EQS |
| 8 | 12 | 0.66 ⁴ | 1.51 ⁵ | 0.86 ⁵ | 1.85 | 1.57 | 2.97 | 3.23 | 3.10 | 3.61 |
| | 16 | 0.30 ⁴ | 1.11 ⁴ | 0.49 ⁴ | 1.44 ⁵ | 1.26 | 2.64 | 2.89 | 2.87 | 3.36 |
| | 24 | - | 0.38 ³ | - | 0.68 ⁴ | 0.66 | 2.01 | 2.23 | 2.41 | 2.85 |
| 9 | 12 | 0.34 ³ | 1.09 ⁴ | 0.53 ⁴ | 1.41 ⁵ | 1.31 | 2.68 | 2.90 | 2.90 | 3.40 |
| | 16 | - | 0.65 ⁴ | 0.11 ³ | 0.95 ⁴ | 0.92 | 2.27 | 2.48 | 2.61 | 3.08 |
| | 24 | - | - | - | 0.11 ³ | 0.19 ⁴ | 1.49 | 1.68 | 2.03 | 2.44 |
| 10 | 12 | 0.05 ³ | 0.70 ³ | 0.21 ³ | 0.99 ⁴ | 1.02 | 2.36 | 2.55 | 2.68 | 3.16 |
| | 16 | - | 0.24 ³ | - | 0.50 ³ | 0.56 ⁵ | 1.87 | 2.05 | 2.32 | 2.76 |
| | 24 | - | - | - | - | - | 0.94 ⁴ | 1.10 ⁵ | 1.62 | 1.98 |
| 12 | 12 | - | 0.08 ² | - | 0.28 ³ | 0.39 ⁴ | 1.60 ⁵ | 1.76 | 2.18 | 2.59 |
| | 16 | - | - | - | - | - | 0.97 ⁴ | 1.12 ⁴ | 1.67 | 2.03 |
| | 24 | - | - | - | - | - | - | - | 0.70 ⁵ | 0.96 |
| 14 | 12 | - | - | - | - | - | 0.83 ⁴ | 0.98 ⁴ | 1.59 | 1.92 |
| | 16 | - | - | - | - | - | 0.12 ³ | 0.24 ³ | 0.94 ⁴ | 1.21 ⁵ |
| | 24 | - | - | - | - | - | - | - | - | - |
| 16 | 12 | - | - | - | - | - | 0.15 ³ | 0.26 ³ | 0.96 ⁴ | 1.19 ⁵ |
| | 16 | - | - | - | - | - | - | - | 0.18 ⁴ | 0.35 ⁴ |
| | 24 | - | - | - | - | - | - | - | - | - |

| 50 psf | | | | | | | | | | |
|------------------|------------------------|---------------------------|-------------------|---------------------------|-------------------|---------------------------|-------------------|---------------------------|---------------------------|---------------------------|
| Wall Height (ft) | Spacing (in) on center | 362SFS162-(mil) 57 ksi | | 400SFS162-(mil) 57 ksi | | 600SFS162-(mil) 57 ksi | | 600SFS200-(mil) 57 ksi | 800SFS162-(mil) 57 ksi | 800SFS200-(mil) 57 ksi |
| | | 33EQS | 43EQS | 33EQS | 43EQS | 33EQS | 43EQS | 43EQS | 43EQS | 43EQS |
| 8 | 12 | 0.39 ⁴ | 1.21 ⁴ | 0.58 ⁴ | 1.54 ⁵ | 1.34 | 2.72 | 2.97 | 2.92 | 3.42 |
| | 16 | - | 0.74 ⁴ | 0.14 ⁴ | 1.05 ⁴ | 0.96 | 2.32 | 2.56 | 2.64 | 3.10 |
| | 24 | - | - | - | 0.15 ³ | 0.23 ⁵ | 1.54 | 1.75 | 2.07 | 2.48 |
| 9 | 12 | 0.04 ³ | 0.75 ⁴ | 0.21 ³ | 1.06 ⁴ | 1.02 | 2.37 | 2.59 | 2.68 | 3.16 |
| | 16 | - | 0.24 ³ | - | 0.52 ⁴ | 0.55 ⁵ | 1.88 | 2.08 | 2.32 | 2.76 |
| | 24 | - | - | - | - | - | 0.93 ⁵ | 1.10 ⁵ | 1.61 | 1.97 |
| 10 | 12 | - | 0.35 ³ | - | 0.62 ³ | 0.68 ⁵ | 1.99 | 2.17 | 2.41 | 2.86 |
| | 16 | - | - | - | 0.04 ³ | 0.13 ⁴ | 1.40 ⁵ | 1.57 | 1.97 | 2.37 |
| | 24 | - | - | - | - | - | 0.29 ⁴ | 0.43 ⁴ | 1.11 | 1.41 |
| 12 | 12 | - | - | - | - | - | 1.13 ⁴ | 1.28 ⁴ | 1.80 | 2.17 |
| | 16 | - | - | - | - | - | 0.38 ⁴ | 0.52 ⁴ | 1.18 | 1.49 |
| | 24 | - | - | - | - | - | - | - | 0.01 ⁴ | 0.20 ⁴ |
| 14 | 12 | - | - | - | - | - | 0.29 ³ | 0.41 ⁴ | 1.10 ⁵ | 1.38 |
| | 16 | - | - | - | - | - | - | - | 0.32 ⁴ | 0.52 ⁴ |
| | 24 | - | - | - | - | - | - | - | - | - |
| 16 | 12 | - | - | - | - | - | - | - | 0.37 ⁴ | 0.56 ⁴ |
| | 16 | - | - | - | - | - | - | - | - | - |
| | 24 | - | - | - | - | - | - | - | - | - |

If no note, deflection is less than L/720.

¹Deflection exceeds L/120

²Deflection exceeds L/240

³Deflection exceeds L/360

⁴Deflection exceeds L/600

⁵Deflection exceeds L/720

See Table Notes on page 13

Web Crippling Loads

Table Notes

1. For 33EQD loads, refer to 30EQD values.
2. Listed allowable loads apply only to S-Sections.
3. Listed allowable loads are based on members fastened to supports.
4. Listed allowable loads are for unpunched webs. Capacity reductions for end and interior one flange loading (conditions 1 and 2) near punchouts may be calculated per AISI S100 Specification Section C3.4.2.
5. "h" refers to the flat dimension of the web. See Web Depth-to-Thickness Ratios table on page 7.
6. See page 5 for additional table notes.

Allowable Loads (lbs) - Single Members

| Section (h) | Design Thickness (in) | Thickness (mil) | Fy (ksi) | Condition 1 Fasten to Support | | | Condition 2 Fasten to Support | | | Condition 3 Fasten to Support | | | Condition 4 Fasten to Support | | |
|------------------|-----------------------|-----------------|----------|----------------------------------|-----|-----|----------------------------------|------|------|----------------------------------|-----|-----|----------------------------------|------|------|
| | | | | Bearing Length (in) | | | Bearing Length (in) | | | Bearing Length (in) | | | Bearing Length (in) | | |
| | | | | 1 | 3.5 | 6 | 1 | 3.5 | 6 | 1 | 3.5 | 6 | 1 | 3.5 | 6 |
| 162 | 0.0188 | D20 | 57 | 95 | 155 | 194 | 150 | 216 | 260 | 78 | 110 | 131 | 210 | 277 | 322 |
| 162 | 0.0235 | 30EQD | 57 | 147 | 237 | 296 | 250 | 353 | 422 | 128 | 177 | 210 | 338 | 439 | 506 |
| 250 | 0.0188 | D20 | 57 | 90 | 146 | 183 | 146 | 211 | 254 | 63 | 89 | 106 | 189 | 250 | 290 |
| 250 | 0.0235 | 30EQD | 57 | 140 | 225 | 281 | 244 | 345 | 413 | 108 | 149 | 176 | 309 | 401 | 463 |
| 250 | 0.0295 | 33EQS | 57 | 219 | 347 | 432 | 403 | 561 | 666 | 181 | 246 | 289 | 505 | 645 | 738 |
| 250 | 0.0400 | 43EQS | 57 | 396 | 615 | 761 | 783 | 1063 | 1250 | 356 | 473 | 550 | 969 | 1210 | 1370 |
| 350 | 0.0188 | D20 | 57 | 85 | 138 | 173 | 143 | 206 | 247 | 49 | 69 | 82 | 169 | 224 | 260 |
| 350 | 0.0235 | 30EQD | 57 | 133 | 214 | 267 | 239 | 338 | 404 | 88 | 122 | 145 | 282 | 366 | 422 |
| 350 | 0.0295 | 33EQS | 57 | 209 | 332 | 413 | 396 | 550 | 653 | 155 | 210 | 247 | 468 | 597 | 683 |
| 350 | 0.0400 | 43EQS | 57 | 382 | 593 | 734 | 770 | 1046 | 1230 | 316 | 419 | 488 | 910 | 1136 | 1286 |
| 362 | 0.0188 | D20 | 57 | 84 | 137 | 142 | 142 | 205 | 247 | 47 | 67 | 80 | 167 | 221 | 257 |
| 362 | 0.0235 | 30EQD | 57 | 132 | 213 | 266 | 238 | 337 | 403 | 86 | 119 | 141 | 279 | 362 | 417 |
| 362 | 0.0295 | 33EQS | 57 | 208 | 330 | 411 | 395 | 549 | 652 | 152 | 206 | 243 | 463 | 592 | 677 |
| 362 | 0.0400 | 43EQS | 57 | 380 | 591 | 731 | 769 | 1044 | 1227 | 311 | 413 | 481 | 903 | 1128 | 1277 |
| 400 | 0.0235 | 30EQD | 57 | 130 | 209 | 261 | 236 | 334 | 400 | 80 | 110 | 131 | 270 | 351 | 404 |
| 400 | 0.0295 | 33EQS | 57 | 205 | 325 | 405 | 392 | 546 | 648 | 143 | 195 | 229 | 451 | 576 | 659 |
| 400 | 0.0400 | 43EQS | 57 | 376 | 584 | 722 | 764 | 1039 | 1221 | 298 | 395 | 460 | 884 | 1103 | 1249 |
| 550 ¹ | 0.0235 | 30EQD | 57 | 122 | 196 | 245 | 230 | 326 | 389 | 57 | 79 | 94 | 238 | 309 | 357 |
| 550 | 0.0295 | 33EQS | 57 | 194 | 308 | 384 | 383 | 533 | 633 | 112 | 152 | 179 | 407 | 519 | 594 |
| 550 | 0.0400 | 43EQS | 57 | 359 | 558 | 690 | 749 | 1018 | 1197 | 251 | 332 | 387 | 814 | 1017 | 1151 |
| 600 ¹ | 0.0235 | 30EQD | 57 | 107 | 192 | 240 | 228 | 323 | 386 | 50 | 70 | 83 | 229 | 297 | 342 |
| 600 | 0.0295 | 33EQS | 57 | 191 | 303 | 377 | 380 | 529 | 628 | 103 | 140 | 164 | 393 | 502 | 574 |
| 600 | 0.0400 | 43EQS | 57 | 354 | 550 | 681 | 745 | 1012 | 1190 | 236 | 314 | 365 | 793 | 991 | 1122 |
| 800 | 0.0400 | 43EQS | 57 | 336 | 522 | 646 | 729 | 990 | 1164 | 185 | 245 | 285 | 718 | 897 | 1015 |

¹Bearing length to web height ratio, N/h exceeds limit of 2.

Web Crippling Conditions

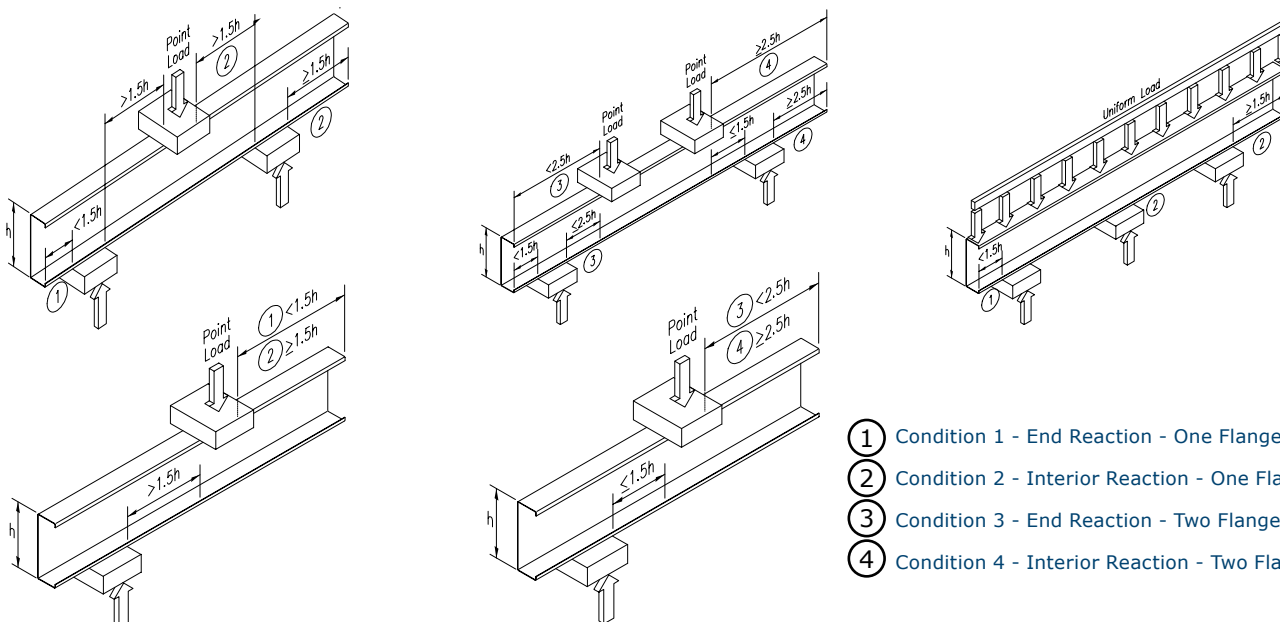

Ceiling Spans

Table Notes

- For 33EQD spans, refer to 30EQD values.
- Values are for simple span conditions.
- For unbraced sections, allowable moment is based on the AISI S100 Section C3.1.2 with unbraced length assumed to be the listed span. For mid-span braced sections, allowable moment is based on AISI S100 Section C3.1.2 with unbraced length assumed to be half of the listed span.
- Web crippling check is based on 1" of bearing at end supports.
- Web crippling and shear capacity have **not** been reduced for punchouts. If web punchouts occur near supports, members must be checked for reduced shear and web crippling in accordance with AISI S100.
- See page 5 for additional table notes.

Deflection Limit L/240 - Ceiling Spans

| Part No. | Fy (ksi) | 4 psf | | | | | | 6 psf | | | | | | 13 psf * | | | | | |
|-----------------------|----------|---------------------------------------|-----------------------|--------|---------------------------------------|-----------------------|---------|---------------------------------------|-----------------------|--------|---------------------------------------|-----------------------|---------|---------------------------------------|-----------------------|--------|---------------------------------------|--------|--------|
| | | Lateral Support of Compression Flange | | | Lateral Support of Compression Flange | | | Lateral Support of Compression Flange | | | Lateral Support of Compression Flange | | | Lateral Support of Compression Flange | | | Lateral Support of Compression Flange | | |
| | | Unsupported | | | Midspan | | | Unsupported | | | Midspan | | | Unsupported | | | Midspan | | |
| Joist Spacing (in) oc | | | Joist Spacing (in) oc | | | Joist Spacing (in) oc | | | Joist Spacing (in) oc | | | Joist Spacing (in) oc | | | Joist Spacing (in) oc | | | | |
| 12 16 24 | | | 12 16 24 | | | 12 16 24 | | | 12 16 24 | | | 12 16 24 | | | 12 16 24 | | | | |
| 162SFS-D20 | 57 | 7' 4" | 6' 8" | 5' 10" | 7' 4" | 6' 8" | 5' 10" | 6' 5" | 5' 10" | 5' 1" | 6' 5" | 5' 10" | 5' 1" | 4' 11" | 4' 6" | 3' 11" | 4' 11" | 4' 6" | 3' 11" |
| 162SFS-30EQD | 57 | 9' 5" | 8' 7" | 7' 6" | 9' 5" | 8' 7" | 7' 6" | 8' 3" | 7' 6" | 6' 6" | 8' 3" | 7' 6" | 6' 6" | 6' 4" | 5' 9" | 5' 0" | 6' 4" | 5' 9" | 5' 0" |
| 250SFS-D20 | 57 | 9' 5" | 8' 9" | 7' 10" | 12' 2" | 11' 1" | 9' 8" | 8' 6" | 7' 10" | 6' 11" | 10' 7" | 9' 8" | 8' 5" | 6' 9" | 6' 2" | 5' 6" | 8' 2" | 7' 5" | 6' 6" |
| 250SFS-30EQD | 57 | 10' 7" | 9' 10" | 8' 10" | 13' 1" | 11' 11" | 10' 5" | 9' 6" | 8' 10" | 7' 11" | 11' 5" | 10' 5" | 9' 1" | 7' 9" | 7' 2" | 6' 5" | 8' 10" | 8' 0" | 7' 0" |
| 350SFS-D20 | 57 | 10' 5" | 9' 8" | 8' 8" | 14' 7" | 13' 4" | 11' 10" | 9' 4" | 8' 8" | 7' 9" | 12' 10" | 11' 10" | 10' 4" | 7' 6" | 6' 11" | 6' 1" | 10' 0" | 9' 0" | 6' 6" |
| 350SFS-30EQD | 57 | 11' 6" | 10' 8" | 9' 7" | 16' 6" | 15' 2" | 13' 5" | 10' 4" | 9' 7" | 8' 7" | 14' 8" | 13' 5" | 11' 10" | 8' 5" | 7' 9" | 6' 11" | 11' 6" | 10' 5" | 9' 0" |
| 362SFS-D20 | 57 | 10' 6" | 9' 9" | 8' 10" | 14' 8" | 13' 6" | 11' 11" | 9' 6" | 8' 10" | 7' 10" | 13' 0" | 11' 11" | 10' 5" | 7' 7" | 7' 0" | 6' 2" | 10' 2" | 9' 2" | 6' 6" |
| 362SFS-30EQD | 57 | 11' 7" | 10' 9" | 9' 8" | 16' 7" | 15' 4" | 13' 7" | 10' 5" | 9' 8" | 8' 8" | 14' 10" | 13' 7" | 12' 0" | 8' 6" | 7' 10" | 7' 0" | 11' 9" | 10' 8" | 9' 2" |
| 400SFS-D20 | 57 | 10' 10" | 10' 1" | 9' 0" | 15' 0" | 13' 9" | 12' 2" | 9' 9" | 9' 0" | 8' 0" | 13' 3" | 12' 2" | 10' 8" | 7' 9" | 7' 2" | 6' 4" | 10' 5" | 9' 5" | 8' 0" |
| 400SFS-30EQD | 57 | 11' 11" | 11' 0" | 9' 11" | 17' 0" | 15' 9" | 14' 0" | 10' 8" | 9' 11" | 8' 11" | 15' 3" | 14' 0" | 12' 5" | 8' 8" | 8' 1" | 7' 2" | 12' 1" | 11' 1" | 9' 7" |
| 550SFS-30EQD | 57 | 13' 3" | 12' 4" | 11' 1" | 19' 3" | 17' 11" | 16' 2" | 11' 11" | 11' 1" | 10' 0" | 17' 5" | 16' 2" | 14' 6" | 9' 10" | 9' 1" | 8' 3" | 14' 1" | 12' 4" | 8' 3" |
| 600SFS-30EQD | 57 | 13' 7" | 12' 7" | 11' 4" | 19' 5" | 18' 0" | 16' 2" | 12' 3" | 11' 4" | 10' 2" | 17' 5" | 16' 2" | 14' 5" | 9' 11" | 9' 2" | 8' 3" | 14' 1" | 12' 4" | 8' 3" |

Deflection Limit L/360 - Ceiling Spans

| Part No. | Fy (ksi) | 4 psf | | | | | | 6 psf | | | | | | 13 psf * | | | | | |
|-----------------------|----------|---------------------------------------|-----------------------|--------|---------------------------------------|-----------------------|---------|---------------------------------------|-----------------------|--------|---------------------------------------|-----------------------|--------|---------------------------------------|-----------------------|--------|---------------------------------------|--------|--------|
| | | Lateral Support of Compression Flange | | | Lateral Support of Compression Flange | | | Lateral Support of Compression Flange | | | Lateral Support of Compression Flange | | | Lateral Support of Compression Flange | | | Lateral Support of Compression Flange | | |
| | | Unsupported | | | Midspan | | | Unsupported | | | Midspan | | | Unsupported | | | Midspan | | |
| Joist Spacing (in) oc | | | Joist Spacing (in) oc | | | Joist Spacing (in) oc | | | Joist Spacing (in) oc | | | Joist Spacing (in) oc | | | Joist Spacing (in) oc | | | | |
| 12 16 24 | | | 12 16 24 | | | 12 16 24 | | | 12 16 24 | | | 12 16 24 | | | 12 16 24 | | | | |
| 162SFS-D20 | 57 | 6' 5" | 5' 10" | 5' 1" | 6' 5" | 5' 10" | 5' 1" | 5' 7" | 5' 1" | 4' 5" | 5' 7" | 5' 1" | 4' 5" | 4' 4" | 3' 11" | 3' 5" | 4' 4" | 3' 11" | 3' 5" |
| 162SFS-30EQD | 57 | 8' 3" | 7' 6" | 6' 6" | 8' 3" | 7' 6" | 6' 6" | 7' 2" | 6' 6" | 5' 8" | 7' 2" | 6' 6" | 5' 8" | 5' 7" | 5' 0" | 4' 5" | 5' 7" | 5' 0" | 4' 5" |
| 250SFS-D20 | 57 | 9' 5" | 8' 9" | 7' 10" | 10' 7" | 9' 8" | 8' 5" | 8' 6" | 7' 10" | 6' 11" | 9' 3" | 8' 5" | 7' 4" | 6' 9" | 6' 2" | 5' 6" | 7' 2" | 6' 6" | 5' 8" |
| 250SFS-30EQD | 57 | 10' 7" | 9' 10" | 8' 10" | 11' 5" | 10' 5" | 9' 1" | 9' 6" | 8' 10" | 7' 11" | 10' 0" | 9' 1" | 7' 11" | 7' 9" | 7' 0" | 6' 1" | 7' 9" | 7' 0" | 6' 1" |
| 350SFS-D20 | 57 | 10' 5" | 9' 8" | 8' 8" | 13' 8" | 12' 5" | 10' 10" | 9' 4" | 8' 8" | 7' 9" | 11' 11" | 10' 10" | 9' 6" | 7' 6" | 6' 11" | 6' 1" | 9' 3" | 8' 5" | 6' 6" |
| 350SFS-30EQD | 57 | 11' 6" | 10' 8" | 9' 7" | 14' 11" | 13' 6" | 11' 10" | 10' 4" | 9' 7" | 8' 7" | 13' 0" | 11' 10" | 10' 4" | 8' 5" | 7' 9" | 6' 11" | 10' 0" | 9' 1" | 7' 11" |
| 362SFS-D20 | 57 | 10' 6" | 9' 9" | 8' 10" | 14' 0" | 12' 9" | 11' 2" | 9' 6" | 8' 10" | 7' 10" | 12' 3" | 11' 2" | 9' 9" | 7' 7" | 7' 0" | 6' 2" | 9' 6" | 8' 7" | 6' 6" |
| 362SFS-30EQD | 57 | 11' 7" | 10' 9" | 9' 8" | 15' 4" | 13' 11" | 12' 2" | 10' 5" | 9' 8" | 8' 8" | 13' 4" | 12' 2" | 10' 7" | 8' 6" | 7' 10" | 7' 0" | 10' 4" | 9' 4" | 8' 2" |
| 400SFS-D20 | 57 | 10' 10" | 10' 1" | 9' 0" | 14' 10" | 13' 6" | 11' 9" | 9' 9" | 9' 0" | 8' 0" | 13' 0" | 11' 9" | 10' 4" | 7' 9" | 7' 2" | 6' 4" | 10' 0" | 9' 1" | 8' 0" |
| 400SFS-30EQD | 57 | 11' 11" | 11' 0" | 9' 11" | 16' 6" | 15' 0" | 13' 1" | 10' 8" | 9' 11" | 8' 11" | 14' 5" | 13' 1" | 11' 5" | 8' 8" | 8' 1" | 7' 2" | 11' 2" | 10' 2" | 8' 10" |
| 550SFS-30EQD | 57 | 13' 3" | 12' 4" | 11' 1" | 19' 3" | 17' 11" | 16' 2" | 11' 11" | 11' 1" | 10' 0" | 17' 5" | 16' 2" | 14' 6" | 9' 10" | 9' 1" | 8' 3" | 14' 1" | 12' 4" | 8' 3" |
| 600SFS-30EQD | 57 | 13' 7" | 12' 7" | 11' 4" | 19' 5" | 18' 0" | 16' 2" | 12' 3" | 11' 4" | 10' 2" | 17' 5" | 16' 2" | 14' 5" | 9' 11" | 9' 2" | 8' 3" | 14' 1" | 12' 4" | 8' 3" |

*Loads that exceed 10 psf limit require a G60 galvanized coating.
 "e" Web stiffeners required at ends.

Mid-Span Bracing Details

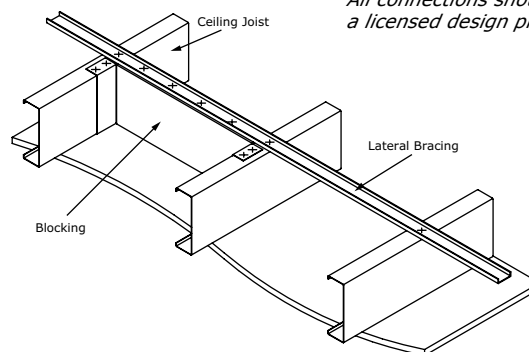
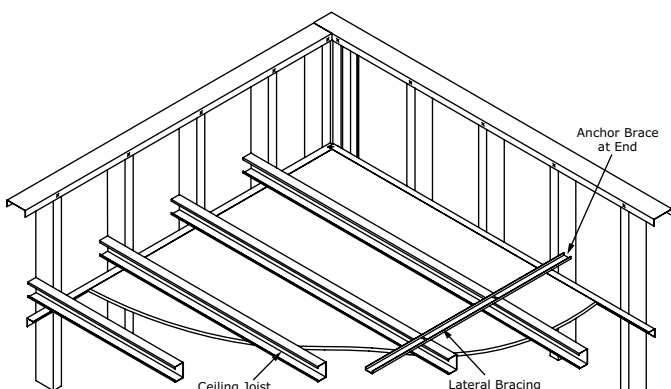

General Note:
 All connections should be designed by a licensed design professional.

Hat Channel Section Properties

Table Notes

1. For 33EQD properties, refer to 30EQD values.
2. If present, hems and offsets in flanges are ignored.
3. Effective properties are given as the minimum value for positive or negative bending.
4. See page 5 for additional table notes.

SFS (Hat) Furring (F) Channel Section Properties

| Part No. | F _y (ksi) | Design Thickness (in) | Gross Properties | | | | | Effective Properties | | | |
|---------------|----------------------|-----------------------|-------------------------|----------------|-----------------------------------|---------------------|-----------------------------------|----------------------|-----------------------------------|-----------------------------------|------------|
| | | | Area (in ²) | Weight (lb/ft) | I _x (in ⁴) | R _x (in) | I _y (in ⁴) | R _y (in) | I _x (in ⁴) | S _x (in ³) | Ma (ft-lb) |
| 087F125-D20 | 57 | 0.0188 | 0.070 | 0.239 | 0.009 | 0.357 | 0.0354 | 0.711 | 0.0080 | 0.0146 | 41.39 |
| 087F125-30EQD | 57 | 0.0235 | 0.087 | 0.297 | 0.011 | 0.355 | 0.0441 | 0.711 | 0.0104 | 0.0195 | 55.41 |
| 087F125-33EQS | 57 | 0.0295 | 0.109 | 0.370 | 0.014 | 0.353 | 0.0550 | 0.711 | 0.0135 | 0.0262 | 74.39 |
| 087F125-43EQS | 57 | 0.0400 | 0.145 | 0.495 | 0.018 | 0.350 | 0.0734 | 0.711 | 0.0178 | 0.0381 | 108.48 |
| 150F125-30EQD | 57 | 0.0235 | 0.117 | 0.398 | 0.038 | 0.574 | 0.0581 | 0.705 | 0.0368 | 0.0421 | 119.63 |
| 150F125-33EQS | 57 | 0.0295 | 0.146 | 0.497 | 0.048 | 0.572 | 0.0726 | 0.705 | 0.0472 | 0.0557 | 158.43 |
| 150F125-43EQS | 57 | 0.0400 | 0.196 | 0.667 | 0.063 | 0.568 | 0.0974 | 0.705 | 0.0631 | 0.0802 | 228.11 |

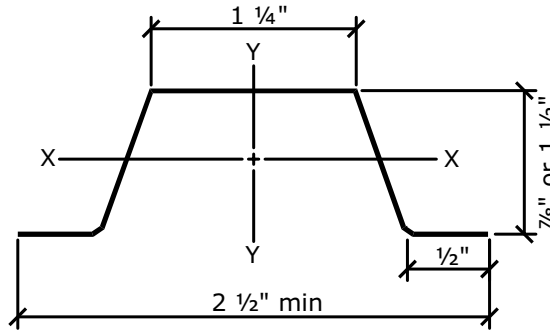

Hat Channel Span Tables

Table Notes

1. For 33EQD spans, refer to 30EQD values.
2. Web crippling check is based on 1" of bearing at end and interior supports.
3. Single spans are the minimum span based on moment, shear, web crippling, or deflection.
4. Multiple spans are the minimum spans based on moment, shear, web crippling, deflection, combined bending and shear, or combined bending and web crippling.
5. Multiple spans indicate two or more equal and continuous spans with span length measured support to support.
6. See page 5 for additional table notes.

SFS (Hat) Furring (F) Channel Allowable Ceiling Spans L/240

| Part No. | F _y (ksi) | Spans | 4 psf | | | 6 psf | | | 13 psf* | | |
|---------------|----------------------|----------|------------------------|--------|--------|------------------------|--------|--------|------------------------|--------|--------|
| | | | Spacing (in) on center | | | Spacing (in) on center | | | Spacing (in) on center | | |
| | | | 12 | 16 | 24 | 12 | 16 | 24 | 12 | 16 | 24 |
| 087F125-D20 | 57 | Single | 5' 1" | 4' 7" | 4' 0" | 4' 5" | 4' 0" | 3' 6" | 3' 5" | 3' 1" | 2' 9" |
| | | Multiple | 6' 4" | 5' 9" | 5' 0" | 5' 6" | 5' 0" | 4' 4" | 4' 3" | 3' 10" | 3' 4" |
| 087F125-30EQD | 57 | Single | 5' 7" | 5' 1" | 4' 5" | 4' 10" | 4' 5" | 3' 10" | 3' 9" | 3' 5" | 3' 0" |
| | | Multiple | 6' 10" | 6' 3" | 5' 5" | 6' 0" | 5' 5" | 4' 9" | 4' 8" | 4' 3" | 3' 8" |
| 087F125-33EQS | 57 | Single | 6' 1" | 5' 6" | 4' 10" | 5' 3" | 4' 10" | 4' 2" | 4' 1" | 3' 9" | 3' 3" |
| | | Multiple | 7' 6" | 6' 10" | 5' 11" | 6' 6" | 5' 11" | 5' 2" | 5' 1" | 4' 7" | 4' 0" |
| 087F125-43EQS | 57 | Single | 6' 8" | 6' 0" | 5' 3" | 5' 10" | 5' 3" | 4' 7" | 4' 6" | 4' 1" | 3' 7" |
| | | Multiple | 8' 2" | 7' 5" | 6' 6" | 7' 2" | 6' 6" | 5' 8" | 5' 6" | 5' 0" | 4' 5" |
| 150F125-30EQD | 57 | Single | 8' 5" | 7' 8" | 6' 8" | 7' 5" | 6' 8" | 5' 10" | 5' 8" | 5' 2" | 4' 6" |
| | | Multiple | 10' 5" | 9' 6" | 8' 4" | 9' 2" | 8' 4" | 7' 3" | 7' 1" | 6' 5" | 5' 7" |
| 150F125-33EQS | 57 | Single | 9' 2" | 8' 4" | 7' 3" | 8' 0" | 7' 3" | 6' 4" | 6' 2" | 5' 8" | 4' 11" |
| | | Multiple | 11' 4" | 10' 4" | 9' 0" | 9' 11" | 9' 0" | 7' 10" | 7' 8" | 7' 0" | 6' 1" |
| 150F125-43EQS | 57 | Single | 10' 1" | 9' 2" | 8' 0" | 8' 10" | 8' 0" | 7' 0" | 6' 10" | 6' 2" | 5' 5" |
| | | Multiple | 12' 6" | 11' 4" | 9' 11" | 10' 11" | 9' 11" | 8' 8" | 8' 5" | 7' 8" | 6' 8" |

*Loads that exceed 10 psf limit require a G60 galvanized coating.

SFS (Hat) Furring (F) Channel Allowable Ceiling Spans L/360

| Part No. | Fy (ksi) | Spans | 4 psf | | | 6 psf | | | 13 psf * | | |
|---------------|----------|----------|------------------------|--------|--------|-----------------|--------|--------|-----------------|--------|--------|
| | | | Spacing (in) on center | | | Spacing (in) oc | | | Spacing (in) oc | | |
| | | | 12 | 16 | 24 | 12 | 16 | 24 | 12 | 16 | 24 |
| 087F125-D20 | 57 | Single | 4' 5" | 4' 0" | 3' 6" | 3' 11" | 3' 6" | 3' 1" | 3' 0" | 2' 9" | 2' 5" |
| | | Multiple | 5' 6" | 5' 0" | 4' 4" | 4' 10" | 4' 4" | 3' 10" | 3' 9" | 3' 4" | 2' 11" |
| 087F125-30EQD | 57 | Single | 4' 10" | 4' 5" | 3' 10" | 4' 3" | 3' 10" | 3' 4" | 3' 3" | 3' 0" | 2' 7" |
| | | Multiple | 6' 0" | 5' 5" | 4' 9" | 5' 3" | 4' 9" | 4' 2" | 4' 1" | 3' 8" | 3' 3" |
| 087F125-33EQS | 57 | Single | 5' 3" | 4' 10" | 4' 2" | 4' 7" | 4' 2" | 3' 8" | 3' 7" | 3' 3" | 2' 10" |
| | | Multiple | 6' 6" | 5' 11" | 5' 2" | 5' 9" | 5' 2" | 4' 6" | 4' 5" | 4' 0" | 3' 6" |
| 087F125-43EQS | 57 | Single | 5' 10" | 5' 3" | 4' 7" | 5' 1" | 4' 7" | 4' 0" | 3' 11" | 3' 7" | 3' 1" |
| | | Multiple | 7' 2" | 6' 6" | 5' 8" | 6' 3" | 5' 8" | 5' 0" | 4' 10" | 4' 5" | 3' 10" |
| 150F125-30EQD | 57 | Single | 7' 5" | 6' 8" | 5' 10" | 6' 5" | 5' 10" | 5' 1" | 5' 0" | 4' 6" | 3' 11" |
| | | Multiple | 9' 2" | 8' 4" | 7' 3" | 8' 0" | 7' 3" | 6' 4" | 6' 2" | 5' 7" | 4' 11" |
| 150F125-33EQS | 57 | Single | 8' 0" | 7' 3" | 6' 4" | 7' 0" | 6' 4" | 5' 7" | 5' 5" | 4' 11" | 4' 4" |
| | | Multiple | 9' 11" | 9' 0" | 7' 10" | 8' 8" | 7' 10" | 6' 11" | 6' 8" | 6' 1" | 5' 4" |
| 150F125-43EQS | 57 | Single | 8' 10" | 8' 0" | 7' 0" | 7' 9" | 7' 0" | 6' 2" | 6' 0" | 5' 5" | 4' 9" |
| | | Multiple | 10' 11" | 9' 11" | 8' 8" | 9' 7" | 8' 8" | 7' 7" | 7' 5" | 6' 8" | 5' 10" |

*Loads that exceed 10 psf limit require a G60 galvanized coating.

Supreme Acoustical Performance Testing

All acoustical data was independently tested by Riverbank Acoustical Laboratories. Riverbank Acoustical is a nationally recognized company accredited by the National Institute of Standards and Technology (NIST) through the National Voluntary Laboratory Accreditation Program (NVLAP).



Partition Type 1

38 STC
3 5/8" Stud



Partition Type 2

47 STC
3 5/8" Stud



Partition Type 3

52 STC
3 5/8" Stud



Partition Type 4

61 STC
3 5/8" Stud

Partition Specifications

| Partition Type | Side A | Side B | Gypsum Type | Insulation Type | Stud Spacing | STC Rating |
|----------------|----------|------------------|-------------|-----------------|--------------|------------|
| 1 | 1 layer | 1 layer | 5/8" Type X | - | 24" oc | 38 |
| 2 | 1 layer | 1 layer | 5/8" Type X | R-11 insulated | 24" oc | 47 |
| 3 | 1 layer | 1 layer on RC-1 | 5/8" Type X | R-11 insulated | 24" oc | 52 |
| 4 | 2 layers | 2 layers on RC-1 | 5/8" Type X | R-11 insulated | 24" oc | 61 |

Supreme Fire-Rated Assemblies UL Approved Designs



Fire Testing Data ASTM E 119

One-Hour Wall Assemblies Non-Load Bearing

1 5/8" · 2 1/2" · 3 5/8" · 4" · 6"

One-Hour Wall Assembly

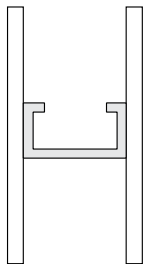

- Studs spaced 24" oc
- One layer of gypsum wallboard (GWB per UL design assembly)
- No insulation required

One-Hour Chase Wall Assembly

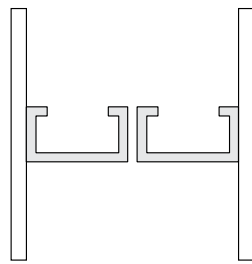

- Two rows of Supreme Studs
- Studs spaced 24" oc
- Can be aligned with 1" minimum spacing between studs from each row, staggered, or staggered and overlapped
- One layer of gypsum wallboard (GWB per UL design assembly)
- No insulation required

Two-Hour Wall Assemblies Non-Load Bearing

1 5/8" · 2 1/2" · 3 5/8" · 4" · 6"

Two-Hour Wall Assembly

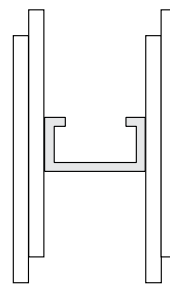

- Studs spaced 24" oc
- Two layers of gypsum wallboard (GWB per UL design assembly)
- No insulation required

Two-Hour Chase Wall Assembly

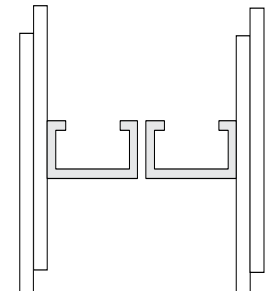

- Two rows of Supreme Studs
- Studs spaced 24" oc
- Can be aligned with 1" minimum spacing between studs from each row, staggered, or staggered and overlapped
- Two layers of gypsum wallboard (GWB per UL design assembly)
- No insulation required

**UL Classifications for
Supreme Framing System**

V486, V496, V498,
U411, U412, U419,
U435, U465, U493

Supreme Deep Leg Deflection Track



Fully sheathed with no additional bracing



Kwik-Bridged Punched Stud non-sheathed with CRC 12" down from end of stud on each side



Non-sheathed with CRC 12" down from end of stud on each side

Nomenclature Example:

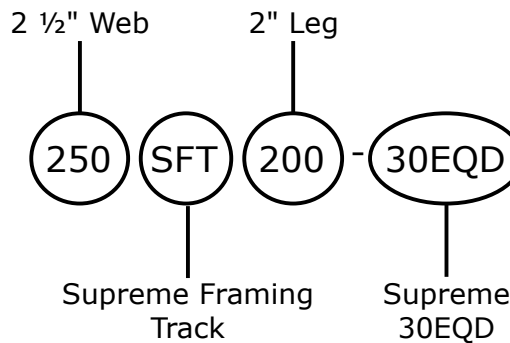

| Supreme Framing Deep Leg Track (SFT) | | | | | | | |
|--|--------------|----------|---------|-------|-------|-------|-------|
| Track Member (W) | Leg Size (H) | Gap (in) | Coating | | | | |
| | | | D20 | 30EQD | 33EQD | 33EQS | 43EQS |
| 2 1/2", 3 1/2", 3 3/4", 4", 5 1/2", 6", 8" | 2" | 1/2" | G40 | G40 | G60 | G60 | G60 |
| | 2 1/2" | 3/4" | G40 | G40 | G60 | G60 | G60 |
| | 3" | 1" | G40 | G40 | G60 | G60 | G60 |

*8" members are only available in 43EQS.

Supreme Slotted Track

SCAFCO Supreme Slotted Track is the industry preferred system for achieving head-of-wall deflection and fire-rated assemblies for interior and exterior walls. It also provides a positive wall attachment and allows up to 1 1/2" of vertical movement.

- Available in all standard stud widths
- Standard lengths are 10' (additional lengths available)
- Corrosion resistant galvanized coating
- 57 ksi yield strength (mill certified steel)



| Quantity / Order Information | | | | | | |
|------------------------------|--------------------|----------------|------------------|-----------|------------|-------------------|
| Part No. | Galvanized Coating | Yield Strength | Design Thickness | Web Width | Leg Height | Stock Length (ft) |
| 162SLT250-30EQD | G40* | 57 | 0.0235 | 1 5/8" | 2 1/2" | 10 |
| 250SLT250-30EQD | G40* | 57 | 0.0235 | 2 1/2" | 2 1/2" | 10 |
| 362SLT250-30EQD | G40* | 57 | 0.0235 | 3 5/8" | 2 1/2" | 10 |
| 400SLT250-30EQD | G40* | 57 | 0.0235 | 4" | 2 1/2" | 10 |
| 600SLT250-30EQD | G40* | 57 | 0.0235 | 6" | 2 1/2" | 10 |
| 250SLT250-33EQS | G60 | 57 | 0.0295 | 2 1/2" | 2 1/2" | 10 |
| 362SLT250-33EQS | G60 | 57 | 0.0295 | 3 5/8" | 2 1/2" | 10 |
| 400SLT250-33EQS | G60 | 57 | 0.0295 | 4" | 2 1/2" | 10 |
| 600SLT250-33EQS | G60 | 57 | 0.0295 | 6" | 2 1/2" | 10 |
| 250SLT250-43EQS | G60 | 57 | 0.0400 | 2 1/2" | 2 1/2" | 10 |
| 362SLT250-43EQS | G60 | 57 | 0.0400 | 3 5/8" | 2 1/2" | 10 |
| 400SLT250-43EQS | G60 | 57 | 0.0400 | 4" | 2 1/2" | 10 |
| 600SLT250-43EQS | G60 | 57 | 0.0400 | 6" | 2 1/2" | 10 |
| 800SLT250-43EQS | G60 | 57 | 0.0400 | 8" | 2 1/2" | 10 |

*Also available in G60 galvanized coating (33EQD).

Supreme Slotted Track UL Specifications



UL Classified for US and Canada
UL File No. R25017

UL Underwriters Laboratories
Supreme Framing Classification

UL 263 Fire Tests of Building Construction and Materials

UL Head-of-Wall Joint Systems Design Numbers

| | | | | | | | | | | |
|-----------|-----------|-----------|-----------|-----------|-----------|-----------|-----------|-----------|-----------|-----------|
| HW-D-0003 | HW-D-0016 | HW-D-0020 | HW-D-0021 | HW-D-0024 | HW-D-0025 | HW-D-0029 | HW-D-0031 | HW-D-0034 | HW-D-0036 | HW-D-0042 |
| HW-D-0043 | HW-D-0044 | HW-D-0045 | HW-D-0046 | HW-D-0047 | HW-D-0048 | HW-D-0049 | HW-D-0054 | HW-D-0062 | HW-D-0063 | HW-D-0067 |
| HW-D-0068 | HW-D-0069 | HW-D-0071 | HW-D-0072 | HW-D-0073 | HW-D-0076 | HW-D-0077 | HW-D-0082 | HW-D-0083 | HW-D-0084 | HW-D-0085 |
| HW-D-0087 | HW-D-0088 | HW-D-0089 | HW-D-0091 | HW-D-0099 | HW-D-0101 | HW-D-0102 | HW-D-0106 | HW-D-0107 | HW-D-0108 | HW-D-0111 |
| HW-D-0134 | HW-D-0136 | HW-D-0137 | HW-D-0144 | HW-D-0146 | HW-D-0152 | HW-D-0154 | HW-D-0160 | HW-D-0162 | HW-D-0167 | HW-D-0170 |
| HW-D-0173 | HW-D-0183 | HW-D-0184 | HW-D-0185 | HW-D-0186 | HW-D-0190 | HW-D-0193 | HW-D-0194 | HW-D-0195 | HW-D-0205 | HW-D-0210 |
| HW-D-0217 | HW-D-0218 | HW-D-0241 | HW-D-0242 | HW-D-0243 | HW-D-0246 | HW-D-0259 | HW-D-0260 | HW-D-0263 | HW-D-0265 | HW-D-0271 |
| HW-D-0272 | HW-D-0275 | HW-D-0277 | HW-D-0278 | HW-D-0293 | HW-D-0313 | HW-D-0322 | HW-D-0341 | | | |

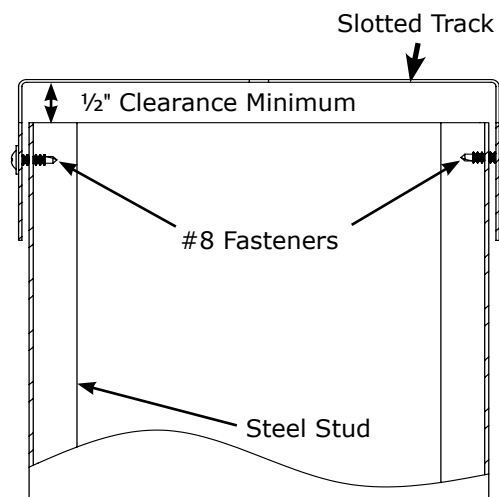

Supreme Z-Furring

Z-Furring channels are ideal for furring out masonry or concrete walls to support rigid insulation board, fiberglass, or mineral insulation.

- Available widths are 1", 1 1/2", and 2" (custom widths available)
- Standard lengths are 10' (additional lengths available)
- Corrosion resistant galvanized coating
- 57 ksi yield strength (mill certified steel)

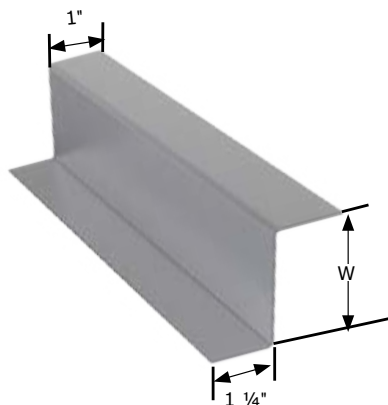

| Quantity / Order Information | | | | | |
|------------------------------|--------------------|----------------|------------------|---------------|-------------------|
| Part No. | Galvanized Coating | Yield Strength | Design Thickness | Web (W) Width | Stock Length (ft) |
| 100ZF125-D20 | G40 | 57 | 0.0188 | 1" | 10 |
| 150ZF125-D20 | G40 | 57 | 0.0188 | 1 1/2" | 10 |
| 200ZF125-D20 | G40 | 57 | 0.0188 | 2" | 10 |
| 100ZF125-30EQD | G40* | 57 | 0.0235 | 1" | 10 |
| 150ZF125-30EQD | G40* | 57 | 0.0235 | 1 1/2" | 10 |
| 200ZF125-30EQD | G40* | 57 | 0.0235 | 2" | 10 |
| 100ZF125-33EQS | G60 | 57 | 0.0295 | 1" | 10 |
| 150ZF125-33EQS | G60 | 57 | 0.0295 | 1 1/2" | 10 |
| 200ZF125-33EQS | G60 | 57 | 0.0295 | 2" | 10 |
| 100ZF125-43EQS | G60 | 57 | 0.0400 | 1" | 10 |
| 150ZF125-43EQS | G60 | 57 | 0.0400 | 1 1/2" | 10 |
| 200ZF125-43EQS | G60 | 57 | 0.0400 | 2" | 10 |

*Also available in G60 galvanized coating (33EQD).

Supreme Custom Shapes

SCAFCO offers a broad selection of custom brake shapes for a wide range of construction applications.

- Manufactured to exact order specifications
- Standard lengths are 10' and 12' (additional lengths available)
- Available in various shapes, bends, and leg depths
- Corrosion resistant galvanized coating (G40 and G60)
- 57 ksi yield strength (mill certified steel)
- Flat stock sheets also available

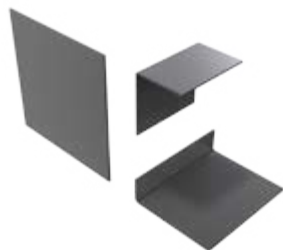

Flat Sheets and Clips



Custom Brake Shape



Custom Angles



Pitch Track



Deep Leg Track



LOCATIONS

Washington

Spokane
509-535-5637

Seattle
425-488-7577

Tacoma
253-840-4455

Tri-Cities
509-542-1411

Yakima
509-452-6777

Idaho

Boise
208-323-4901

Montana

Missoula
406-542-7004

Billings
406-248-2600

Oregon

Portland
503-282-1750

Salem
503-371-8033

Eugene
541-345-8899

California

Sacramento
916-624-7700

Stockton
209-670-8053

San Francisco
415-852-7974

San Jose
408-660-2093

Alaska

Anchorage
907-868-1100

Alberta

Calgary
403-265-9005