



Garage Beam

System Overview



The one forming package that can solve all of your cast-in-place garage forming and estimating problems—and help you make more money!

The Garage Beam system from Symons is a complete forming system designed specifically for post-tensioned beam and slab multi-story parking structures.

A detailed proposal shows all of the components required, suggested pour sequence and pour schedule, and estimated labor requirements. Symons provides the necessary beam form, temporary support, deck system, formwork handling equipment (gas or electric forklifts) and application instructions for efficient concrete placement.

The advantages include:

- ◆ Identifies “true” cost of formwork
- ◆ Minimizes labor requirements
- ◆ One-time initial build-up to start
- ◆ Detailed application drawings
- ◆ Form sequence procedure
- ◆ Speeds positioning and setting
- ◆ Reduces stripping and moving time
- ◆ May eliminate crane-handling
- ◆ Lower overall forming cost
- ◆ High quality concrete finish

Features & Benefits

The Garage Beam system includes design and structural recommendations that simplifies formwork and reduces overall concrete construction costs.

The forming system consists of long (up to 60') beam form assemblies that include high-capacity supports, column and capital forms, and deck forming panels. All of these components are stripped and moved to the next pour position with Symons-supplied forklifts and special moving dollies. The Garage Beam system includes application drawings and a pour sequence schedule that makes concrete forming operations highly productive.

Symons Garage Beam System:

- ◆ Requires no tie systems
- ◆ Requires no incidental bracing
- ◆ Drafted sides to ease stripping
- ◆ Produces smooth concrete finish

Each major Garage Beam system component has an integrated design for maximum forming and labor productivity.

Beam forms are faced with $\frac{3}{16}$ " steel skin plate for strength, durability and excellent concrete finish. Deck panels are field-fabricated using wood "I" joists (supplied by Symons) and high-density overlay (HDO) plywood which produces a consistent, smooth concrete finish. Long-span deck panels allow larger drive aisles for movement of forklifts and dollies, to reduce labor and handling.



How the System Works

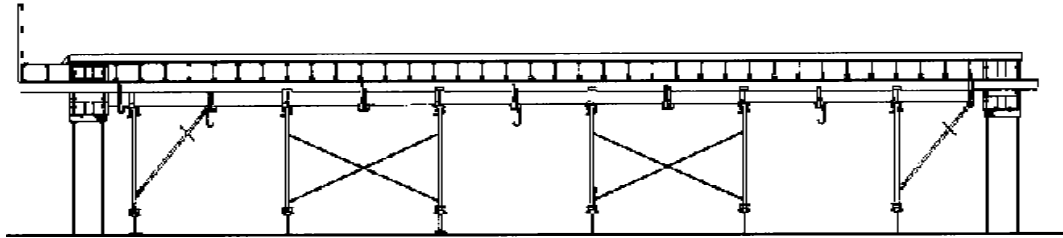

Concrete placement position—load frames extended

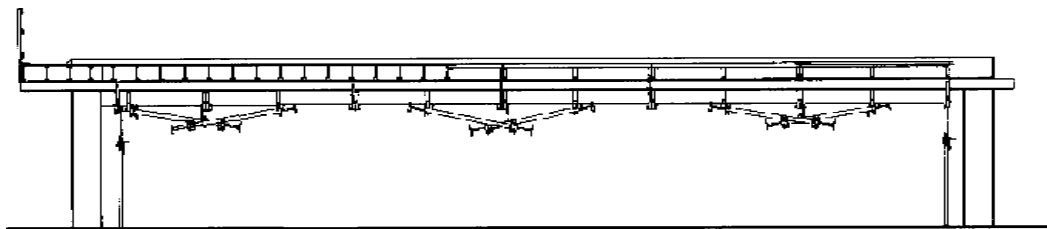

Prepared for stripping—load frames retracted
(Beam dollies and forklifts not shown)

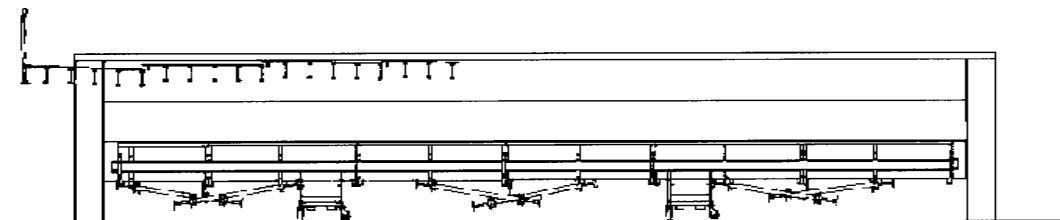

Ready for transport—beam form lowered on dollies

Placement Position

Long span deck panels allow for large, clear work spaces for accessibility and mobility of forklifts.

Prior to actual forming, site-fabricated deck panels and long sections of beam forms are site-assembled before concrete placement, to speed the production cycle.

Prepared for Stripping

Load frames are hinged up and held with frame hooks. Beam dollies are attached to forklifts and brought up to the under side of the beam. The beam is stripped using hydraulic jacks and lowered to the floor using forklifts.

Ready for Transport

Deck panels remain suspended by deck panel bolts as the beam form is lowered. Beam forms are towed to the next pour position and moved into place with forklifts. Deck panels are then lowered on dollies and moved to the next pour. This procedure eliminates the need for alternate storage and reduces lag-time.



Typical Ledger System

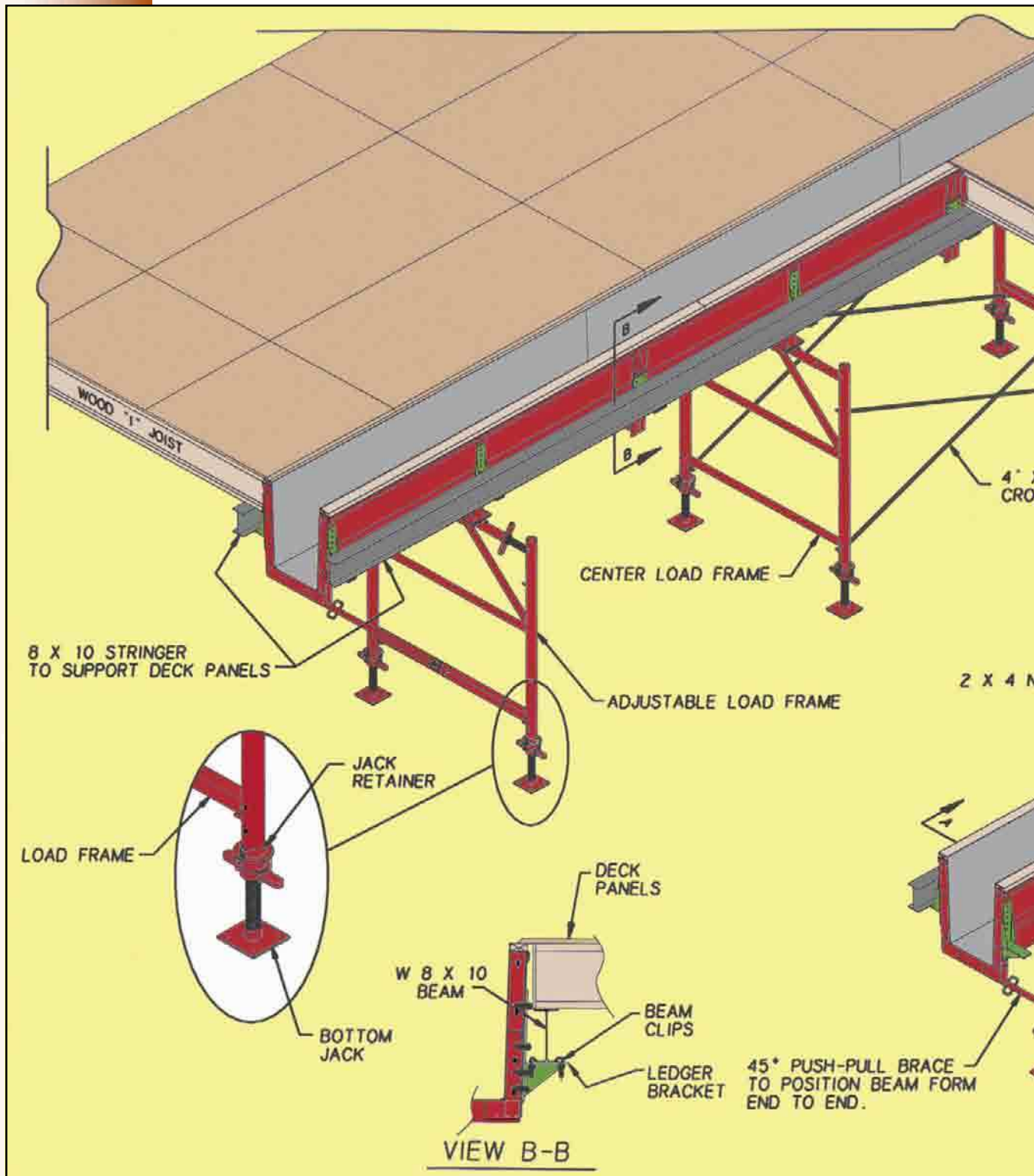

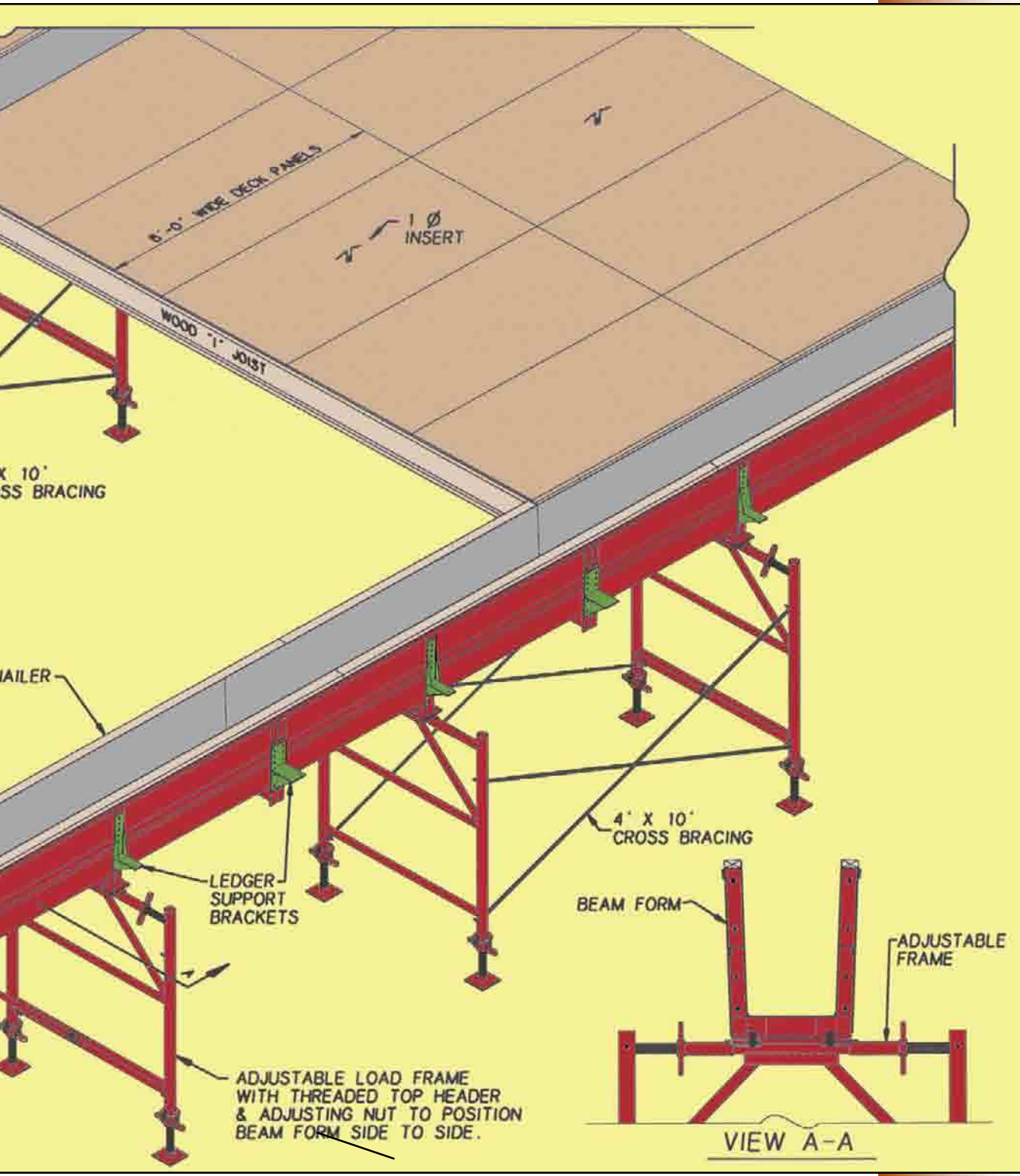

Standard Capital Forms



Capital Forms

All-steel capital forms are designed specifically for typical exterior and “pass-through” interior locations. Forms are steel-faced to produce smooth concrete and include steel chamfer to facilitate stripping and improve finish. Provisions for post-tension cable penetrations are also included in the capital form design.

Capital forms are usually supported by steel friction collars, eliminating the need for independent shoring support and simplifying setting procedures.

For low reuse applications, capital forms can be field-fabricated with plywood and lumber, according to fabrication details provided.

Formwork details are available for special beam intersections, ramp capitals, and other unique applications to meet the production goals for almost any specific project.

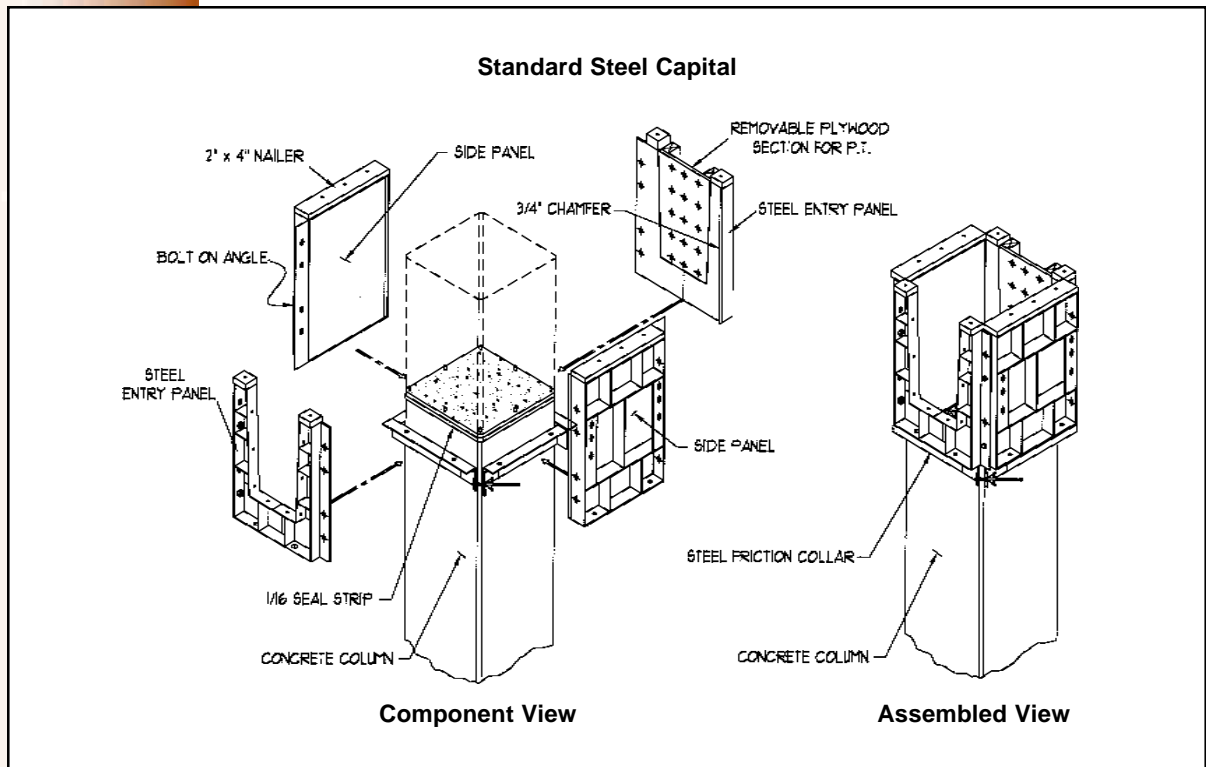

Ramp Capital Forms

Ramp Capital

Ramp capitals are located at column and beam intersections on ramps. These post-tensioned beams often intersect this area at different elevations on opposite sides of the column. These variations typically cause ramp capital forms to be built on-site with field fabrication drawings supplied by Symons. Ramp capitals consist of plywood and dimensional lumber (supplied by contractor) and steel entry panels (supplied by Symons). Ramp capitals are assembled with swing bolt hardware that speeds stripping and resetting procedures. Ramp capitals are supported using steel friction collars.

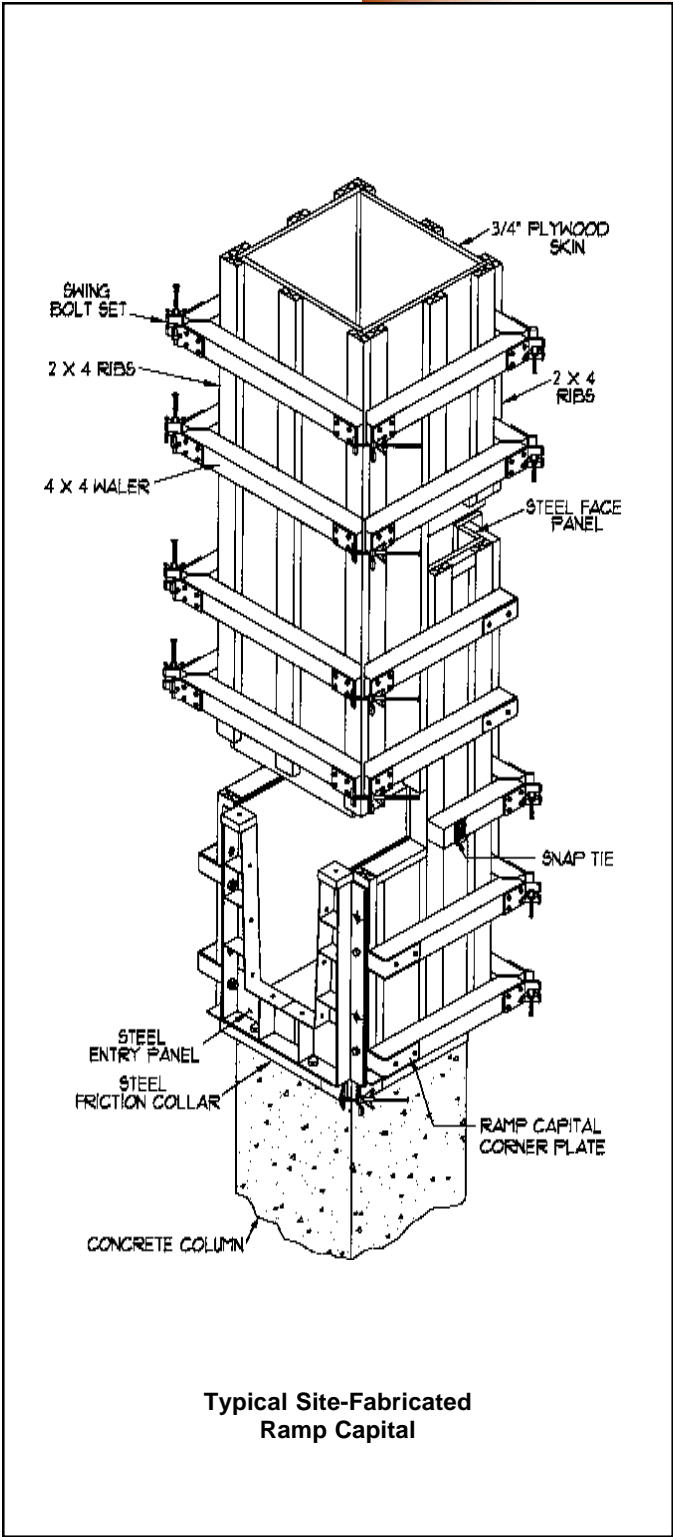

Deck Panels



Deck Panels

Deck panels are field-fabricated using wood "I" joists and high-density overlay plywood. Using the wood "I" joist allows spans up to 22'-0" without center shoring as often seen with other systems on the market. The HDO plywood produces a smooth concrete finish and provides maximum reuse for garage decks. Fabrication details for building deck panels are provided for optimum production during site-fabrication of deck panels.

Sequencing

All Garage Beam system equipment is analyzed for forming operations, post-tensioning sequence and construction schedules.



The long "learning curve" often associated with other forming methods can be reduced with the Garage Beam system because preplanning and field instruction are provided. The system is designed to use the least amount of formwork and labor needed for the desired construction cycle.

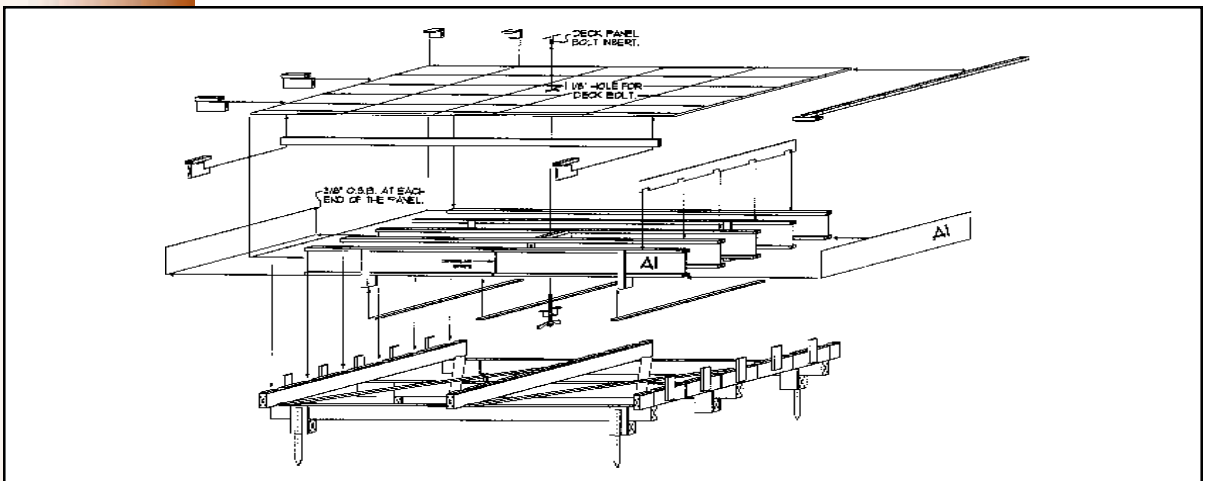

High Quality Concrete Finish

Fabrication

Quality fabrication of the entire system is provided by Symons based on years of experience in concrete formwork design and manufacturing. Only the highest quality materials are used to provide superior form strength, long service life, and excellent concrete finish.

Service

Field service personnel are available to assist during initial formwork assembly and moving sequences. On-site technical service is available to assure uninterrupted progress.



Adjustable Column Form — Form square or rectangular columns efficiently with a minimum number of steel panels.

Alisply™ — Clamp-type metric dimension system is quickly assembled and reconfigured for fast-paced gangforming.

Aluminum Beams and Joists — Lightweight beams/ joists from 4' to 30' (122cm to 914cm) for deck or gangform applications.

Box Culvert Traveler — Rolling steel framework is compatible with Steel-Ply, Versiform and Max-A-Form systems.

Chemicals — Liquid, cement and epoxy products for concrete construction and repair.

Flex-Form® — Specially designed steel-faced system for forming curved walls and round tanks with no surface “chording”.

Form Liner — More than 30 standard patterns, in four different materials, create unique concrete textures.

FrameFast™ — Provide 24,000 lb. (106kN) load capacity per shore frame with spacings from 3' to 15' (91.4cm to 457.2cm).

Garage Beam System — A complete system provides an economical, poured-in-place concrete parking garage.

Max-A-Form® — A durable, all-steel forming system that requires no walers. Ideal for pier caps and self-spanning applications.

Resi-Ply™ — A low cost, 1¹/₈" (2.9cm) plywood forming system for residential construction. Available in 4-bar, 5-bar and 6-bar.

Roller Deck — Column mounted deck support system replaces conventional shoring, providing access for other trades.

ShorFast™ — Aluminum leg and jack shoring system can support up to 30kips (133kN) per leg.

Steel-Ply® — The most popular modular system with more than 80 panel and filler sizes for handset or gangforming.

Symons Soldier™ — The “next generation” construction beam that can be used as a brace, strongback, waler or shore.

Street Smart™ — Reusable steel forms for residential curb and gutters, industrial slabs and highway paving applications.

Symons Silver™ — A lightweight aluminum system that makes residential forming operations very efficient and productive.

Versiform® — Steel frame/plywood face gangforming system that provides a smooth concrete finish.



200 E. Touhy Avenue
Des Plaines, IL 60018 USA
847-298-3200 • FAX 847-635-9287
www.symons.com • info@symons.com



Call 800-800-SYMONS