

T₃ Intelligent Comfort Control Products

T₃SQ VAV Diffusers

Design Guide

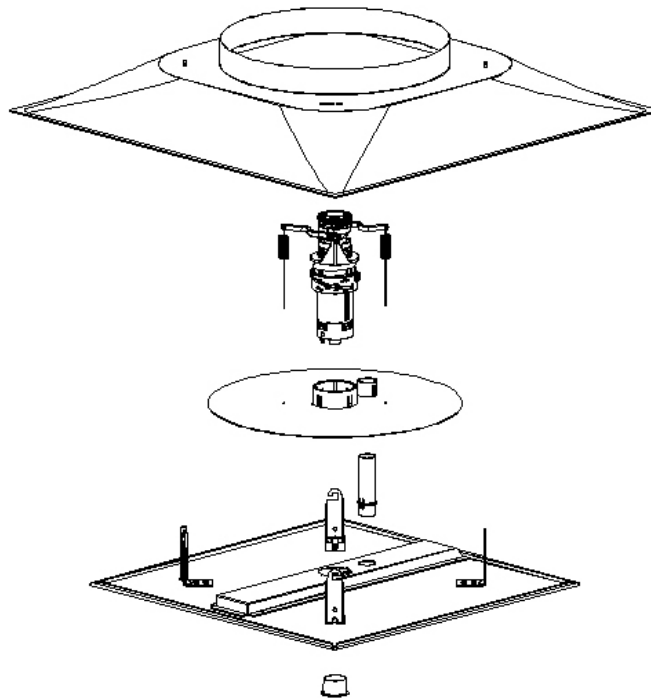

Titus, the Titus Spiral, The Leader in Air Management, and T₃ Intelligent Comfort Control are trademarks of Titus.

All other trademarks, noted or not, are the property of their respective owners.

Contents	Page
General	3
System Overview	3
T₃SQ Duct Design Basics	3
Equal Friction	3
Static Regain.....	3
Pressure Control	4
System Balancing	5
Simple System.....	5
Complex System.....	5
Abbreviations	6

General

This document provides system design basics covering the T₃ Comfort Products T₃SQ VAV diffuser system.

Additional information may be found at the Titus website, www.titus-hvac.com.

System Overview

The T₃SQ is a low pressure, pressure dependent, variable air volume (VAV) system. The T₃SQ is designed to operate around 0.15 to 0.20 inlet pressure. Duct design and near constant pressure control are important to achieve proper airflow and acceptable sound levels from these diffusers.

The T₃SQ provides all of the benefits of a VAV system at low pressure conditions and reduced installation costs.

T₃SQ Duct Design Basics

There are two basic methods for duct design commonly used by engineers: equal friction and static regain. Both will be discussed in this section.

Equal Friction

Most engineers use the equal friction method of duct design. Many retrofit T₃SQ projects will have ductwork that was designed using the equal friction method. With the equal friction method, ducts are sized for a constant static pressure loss due to friction per unit length.

When designing for the T₃SQ, optimally, each diffuser would have a constant inlet pressure in the range of 0.15 to 0.20. Using the equal friction method, this can be difficult to control.

If duct lengths are excessive and friction loss per 100 ft. of duct is high, a large pressure differential from start to end of the duct run will result. If the starting velocity is 1500 fpm, friction loss per 100 ft. of duct can be about 0.20.

For the simple system shown below, you may require a static pressure at the start of the run of 0.36 to satisfy 0.20 static pressure at halfway mark and 0.12 at end of the duct run.

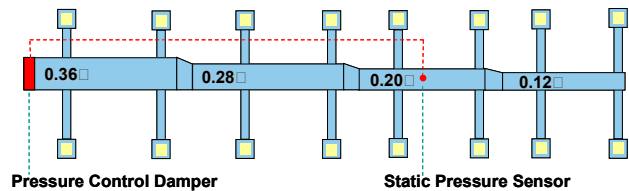

In this system, the first few diffusers are likely to provide too much air and may be noisy. Those halfway down duct run will be satisfied. Those at the end will be short supplied.

As a rule of thumb, if an engineer designs duct using this equal friction, providing a starting air velocity of less than 1000 fpm is used, and duct runs are short, the T₃SQ system will work well.

Flexible duct lengths between supply air ducts and T₃SQ diffusers should be limited to no more than 3-5 ft. and good inlet conditions should be provided. If the distance between supply duct and T₃SQ diffuser is greater than 3-5 ft., the difference should be made up with circular sheet metal duct the same diameter as the neck of the diffuser.

With duct static pressures at +/-10% to 20% of that selected, the system will be a success. But this design method will may not be acceptable if duct runs are long and have numerous bends or restrictions.

Static Regain

In static regain duct design, the objective is to obtain the same static pressure throughout the duct run. Static regain duct design uses the reduction in air velocity, and therefore the reduction of velocity pressure, after each duct section to regain the static pressure loss due to friction in the preceding duct length.

Total pressure = velocity pressure + static pressure ($T_p = V_p + S_p$). If there is no change in total pressure, a reduction in velocity pressure results in an increase in static pressure.

Using the static regain method of duct design, the increase in static pressure at each branch offsets the friction loss in the succeeding section of the duct. The static pressure should then be the same before each T₃SQ and at each branch. The pressure profile of the duct would look like the system shown below.

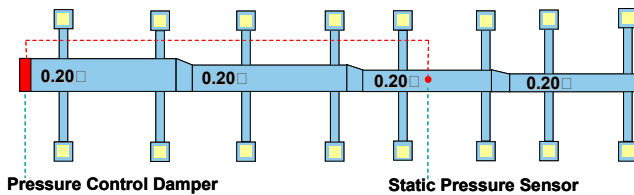

Static regain duct design done manually can be tedious, which is the reason that it is not commonly used. A number duct design programs are available to simplify the process.

The major advantage of the static regain method of duct design is that the static pressure profile along full length of the duct will be constant, allowing the T₃SQ system to perform at optimum and reducing diffuser balancing time.

Flexible duct lengths between supply air ducts and T₃SQ diffusers should be limited to no more than 3-5 ft., with good inlet conditions. If the distance between supply duct and T₃SQ diffuser is greater than 3-5 ft., the difference should be made up with circular sheet metal duct the same diameter as the neck of the diffuser.

Since system ducting has been designed using static regain principles, static pressure profile will be nearly constant and, since each diffuser has its own thermal or analog damper, there is no need for the installation of spin-in dampers.

Pressure Control

In a constant volume system, if 30% or more of the system airflow is being supplied by T₃SQ VAV diffusers, a static pressure control terminal should be installed. This minimizes the potential to provide excess supply air to other diffusers as the T₃SQ diffusers begin to close from full open.

Titus offers two stand-alone pressure control units, the ZECV and the ZQCV. The ZECV is a round pressure control damper. The ZQCV is a rectangular, slip-in pressure control damper. Both units come with static pressure sensors, analog pressure controllers, and an integral differential pressure transducer.

For bypass pressure control applications, the static pressure tap should be placed downstream of the bypass terminal about $\frac{1}{2}$ to $\frac{2}{3}$ the way down the duct run.

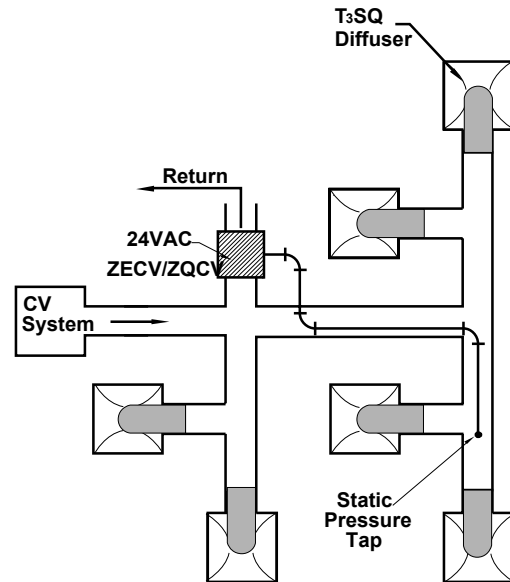

In discharge pressure control applications, the static pressure tap should be placed downstream of the terminal about $\frac{1}{2}$ to $\frac{2}{3}$ the way down the duct run.

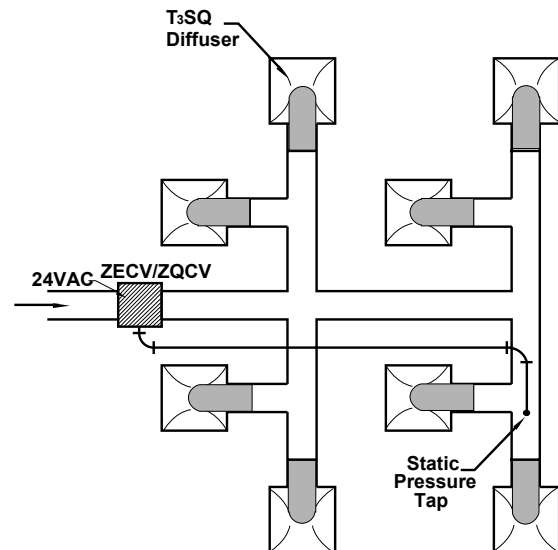

System Balancing

Balancing a T₃SQ system is important for the proper operation of the VAV diffusers.

Simple System

A simple T₃SQ system would be a single duct run of T₃SQ diffusers, like the one shown below.

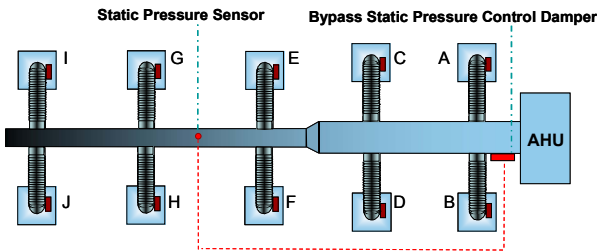

Balancing the T₃SQ VAV system is simple. First, drive open all diffusers. For the thermal T₃SQ this is done by disconnection the actuator arms from the control disc. For the analog T₃SQ, press and hold the down arrow to put the diffuser in override mode, signified by a on the thermostat display, then press the down arrow once to drive the control disc open.

If using bypass pressure control, close all bypass terminal dampers before balancing. If using discharge pressure control, open all discharge pressure control terminal dampers.

Next, select index diffuser. The index diffuser is the diffuser that requires highest pressure to satisfy its design airflow. Measure the airflow of this diffuser. If it is too high, reduce the system duct static pressure. If it is too low, increase the system duct static pressure.

The system is now effectively balanced since remaining diffusers require less pressure will drive as far open as needed to satisfy individual flow rates. Checks can be made to establish that they are able to supply the design airflow.

If the system is constant volume, a bypass pressure control damper is required. The bypass damper should be sized to bypass up to 70% of the system air volume with a maximum face velocity of 1000 fpm. This assumes a minimum of 30% airflow for the diffusers. The bypass damper should be able to provide a tight shut-off to allow full flow to the diffusers, if required.

Complex System

A more complex T₃SQ system may have several duct runs supplied by a main riser, like the one shown below.

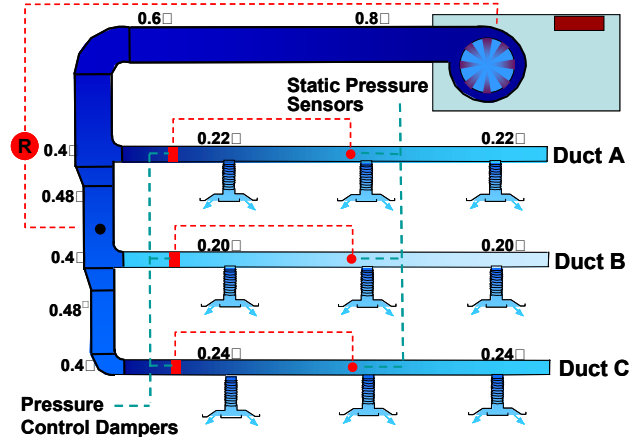

Begin by selecting the index duct. This is the duct requiring the highest static pressure. In the figure above, the index duct would be branch duct C.

If using bypass pressure control, close all bypass terminal dampers before balancing. If using discharge pressure control, open all discharge pressure control terminal dampers.

Next, open all diffusers in this duct run, using the methods discussed in the section above. Then select the index diffuser in this duct run. Again, this is the diffuser requiring the highest pressure.

Measure the airflow of this diffuser. If it is too high, reduce duct static pressure. If it is too low, increase duct static pressure in the main duct riser. Set the static pressure sensor in duct C to control at this resultant pressure in duct C. This leg is now balanced.

Next, select the next index duct and follow same procedure. The pressure in duct A will not affect pressure control within duct C since it has already been set to control at its required pressure.

Continue balancing the branch ducts using the same procedure until the system is balanced.

Abbreviations

The following table lists abbreviations used within this document.

Abbrev.	Term
CV	Constant Volume
CFM	Cubic Feet Per Minute
fpm	Feet Per Minute
VAV	Variable Air Volume