

Butyl Glazing Tape

Preformed butyl tapes have unique properties which allow their use in a diverse spectrum of applications. When choosing a butyl tape as a sealant for a given application, one should understand the properties of the tape and its limitations:

Limitations:

- Tremco tape sealants adhere to surfaces by means of their inherent tack. For proper performance, they must be compressed between surfaces. Preformed tape sealants should not be used as mounting tapes.
- Tremco butyl tape sealants are considered compatible and acceptable for glazing acrylic and polycarbonate sheet. However, the severe thermal movement that is characteristic of such applications can cause permanent deformation and squeeze-out of the tape. Glazing plastic sheet with tape sealants should be restricted to small lites, with a maximum dimension of approximately 36 inches (914mm).
- In solar collector applications, butyl tape sealants are subject to out-gassing at relatively low stagnation temperatures. The resulting condensation can reduce the efficiency of the collectors. The use of tapes in solar collectors should be restricted to low-performance collector systems.

Tremco offers two glazing tapes to the commercial construction industry. One of the most important steps in any tape glazed project is to insure that the correct tape has been selected for the application.

Non-Compression Glazing Systems

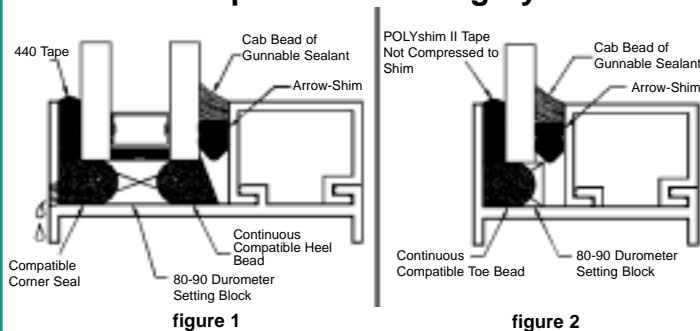

PRIMARY INTENDED USE: 440 Tape

- The Tremco 440 Tape is intended primarily for use in applications in which the tape and a continuous toe bead of compatible sealant are applied to the fixed leg of the glazing pocket, and a spacer with a gammable sealant is installed at the removable stop. (see fig. 1 and fig. 2)
- Systems in which the tape is applied on both sides of the glass or panel, or in which the tape is used without a con-

tinuous compatible toe bead of sealant should be limited to use in residential applications or other applications that are not subject to severe performance requirements.

POLYshim II Tape

- Tremco POLYshim II Tape is intended primarily for use in properly designed compression glazing systems (see fig. 3 and fig. 4). POLYshim II is used in conjunction with a Poly-Wej gasket, a drive-in compression gasket that engages over a specially designed "nub" on the metal, and compatible/gammable sealants.

POLYshim II - Alternate Use:

- Tremco POLYshim II Tape may be specified for use in properly designed non-compression glazing systems (see fig. 2). In these systems the tape is not intended to be compressed to the shim during installation and is not under continuous compression as in a compression glazing system. In these systems the shim performs as a safeguard against over compression.

Preparation:

- Joint surfaces shall be inspected prior to application and any conditions detrimental to achieving a positive, weather-tight seal shall be reported to the General Contractor.
- All openings, joints, or channels to be sealed shall be clean, dry and free from dust, oil grease, loose mortar or any other foreign matter.
- Surfaces with protective coatings that the tape will contact, shall be wiped with a suitable solvent to remove the protective coating and any oil deposit that may be left on that surface.
- All sash and framing members shall be checked prior to glazing to make certain that the opening is square, plumb, and secure in order that uniform face and edge clearances are maintained. Butt and miter joints shall be sealed prior to glazing. All ventilators and operating sash must be properly adjusted and glazed in the closed position.

Application:

NON-COMPRESSION GLAZING SYSTEMS

- The tape shall be sized in accordance with the non-compression section of the Tape Size Selection Chart (Table 2).
- The tape shall be installed in four lengths cut to the appropriate size for each edge. Lengths for two opposite sides should be cut to the daylight dimension. Lengths for the two remaining sides should be cut to the daylight dimension plus 1 in. (25.4mm) for 1/2" (12.7mm) wide tape or plus 3/4" (19 mm) for 3/8" (9.5mm) wide tape.
- Place tape so that the edge is even with the sight line of the stop.



d. If the sash butt joint is in a vertical direction, the tape shall be placed initially on the head and sill members so that the tape forms a seal across the vertical sash joint. Should butt joints in the sash run horizontally, the tape must first be applied to the jambs to provide a seal across the horizontal sash joint. Do not run one continuous length of tape around all four sides. Do not lap the adjoining lengths of tape, as this would prevent full contact of the tape to surfaces around the entire perimeter of the glass or panel.

e. When pre-shimmed tape is installed recessed for use with a cap bead of sealant (see fig.4), the tape shall be placed so that its built-in shim will be at least 1/8-inch (3mm) from the glass edge. Glass bite should allow 3/16-inch (8mm) deep sealant cavity above recessed tape.

f. Remove backing paper from tape just prior to setting glass.

g. Setting blocks of 80-90 Shore "A" Durometer Hardness shall be positioned, two on each sill member, at quarter points. On 180° pivoted sash, setting blocks shall be placed as recommended by the Sash Manufacturer. The setting blocks shall be bedded in a compatible toe bead sealant so that it does not interrupt the toe bead sealant across the sill.

h. The glass shall be set on setting blocks, centered in the opening and pressed firmly against the tape.

i. Install a compatible continuous toe bead bridging from the glass edge to the sash framing. Install edge blocks if required. If a continuous toe bead is not used, a compatible corner seal shall be installed (see figure 5).

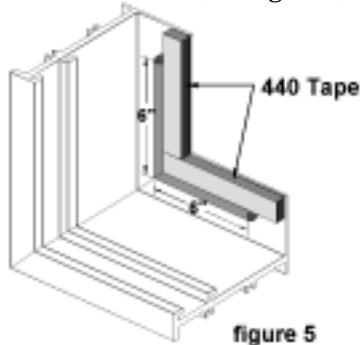

When glass or panels are less than 10 square feet (0.93m²), shims are not required with 440 tape. However, in the opposite side backfill, shims or spacers shall be inserted between the stop and glass, or panel, when a gunnable sealant or mastic is used.

When lites of glass or panels exceed 10 square feet (0.93m²), shims or spacers shall be used on the tape side as well as on the gunnable sealant side of the glass or panel. Tremco POLYshim II Tape is recommended for these applications.

When shims are required, continuous shims are recommended. If individual (intermittent) spacer shims are used, EPDM spacer shims (40 to 60 Shore "A" Hardness), should be placed every 18 inches (460mm) to 24 inches (610mm), and kept 1/4 inch (6mm) below the sight line.

Water tests should be conducted throughout the job in accordance with AAMA 501.2 to assure an effective seal is being achieved.

j. All materials shall be used in accordance with the manufacturer's printed instructions.

COMPRESSION GLAZING SYSTEMS- POLYSHIM II Tape only!

a. The tape shall be sized in accordance with the compression section of the Tape Size Selection Chart (Table 2).

b. The tape shall be installed in four lengths cut to the appropriate size for each edge. Lengths for two opposite sides should be cut to the daylight dimension. Lengths for the two remaining sides should be cut to the daylight dimension plus 1 in. (25.4mm) for 1/2" (12.7mm) wide tape or plus 3/4" (19 mm) for 3/8" (9.5mm) wide tape.

c. Place tape so that the edge is approximately 1/32" (.8mm) below the sight line of the stop.

Compression Glazing Systems

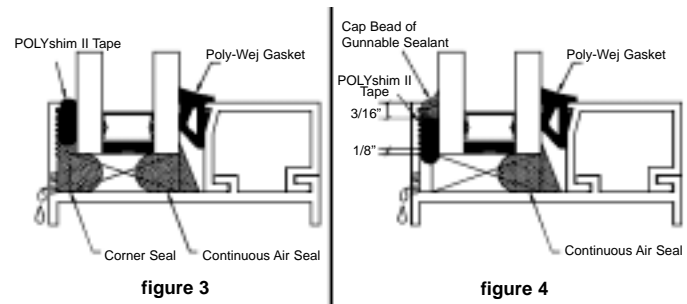

d. If the sash butt joint is in a vertical direction, the tape shall be placed initially on the head and sill members so that the tape forms a seal across the vertical sash joint. Should butt joints in the sash run horizontally, the tape must first be applied to the jambs to provide a seal across the horizontal sash joint. Do not run one continuous length of tape around all four sides. Do not lap the adjoining lengths of tape, as this would prevent full contact of the tape to surfaces around the entire perimeter of the glass or panel.

When an offset condition exists at each corner (where the horizontal member runs behind vertical mullions), two different POLYshim II Tape sizes shall be used. Tremco Technical Services should be contacted to aid in determining the tape sizes required.

The thinner tape should be positioned first. The thicker tape should be cut 1/8 inch (3 mm) longer than the dimension between the applied thinner tapes and should then be installed between the thinner tapes (see figure 6).

e. Each tape section shall butt the adjoining tape and be united with a tool or coin to eliminate any opening. Daub the butted tape joints with sealant for maximum leakproof security.

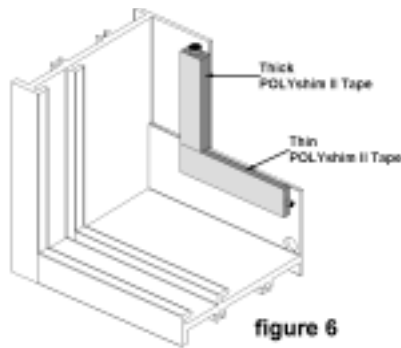

figure 6

f. Just prior to setting the glass, the paper backing shall be removed. Apply a compatible sealant around the tape corners about 6 inches (152mm) in each direction. This sealant bead should be sized so that it will contact the glass when the glass is set. This sealant bead should effectively seal around each corner from the glass to the framing (see figure 5).

g. Setting blocks of 80-90 Shore "A" Hardness shall be positioned, two on each sill member placed at quarter points. On 180° pivoted sash, setting blocks shall be placed as recommended by the sash manufacturer.

h. The glass shall be set on setting blocks, centered in the opening and pressed firmly against the tape.

For systems that make use of a continuous toe bead or heel bead of sealant, the setting blocks shall be bedded in the compatible toe or heel bead sealant so that it does not interrupt the continuity of the sealant bead.

i. Edge blocking. Is used to prevent the lite from "walking". Refer to the glass manufacturer for specific recommendations.

j. When pre-shimmed tape is installed recessed for use with a cap bead of sealant, the tape shall be placed so that its built-in shim will be at least 1/8" (3mm) from the glass edge. Glass bite should allow 3/16" (8mm) deep sealant cavity above recessed tape (see fig. 4.)

k. The tape shall be compressed to the shim. Tape compression is achieved by installation of an appropriately sized Poly-Wej gasket into the channel at the opposite side of the glass.

Gasket Installation

a. The gasket shall be sized in accordance with the Gasket Size Selection Chart (Table 1).

Table 1

GASKET SIZE SELECTION CHART	
DESIGNED FACE CLEARANCE	POLY-WEJ GASKET
1/8" (3.18mm)	PS-1125E
3/16" (4.78mm)	PS-1126E
1/4" (6.35mm)	PS-1127E
3/8" (9.53mm)	PS-1128E

b. Gaskets should be cut at a 45 angle to provide a tight mitred joint at the corners. (See figure 7).



figure 7

c. The gasket shall be installed in four lengths, each cut 1/12" to 1% longer than the daylight dimension.

The gasket should be unreel and allowed to relax at least one hour at temperatures above 50°F (10°C) prior to cutting to length.

d. The gasket is installed by inserting at the corners first, then the middle...working towards the corners.

-all four lengths of gasket should be installed in such a way as to effect uniform compression of the tape. This should be performed with care to avoid pressure points along the glass edge.

-Lifting the weight of the glass off the setting blocks while installing the gasket at the sill will ease installation.

-Using short lengths of gasket as temporary shims to pre-compress the tape will also improve gasket installation.

-Water or Mineral Spirits may be used to lubricate the gasket during installation. Soap solutions, Silicone fluids and sprays or other lubricants that leave a residue are not recommended.

e. The gasket must fully engage over the "nub" on the metal stop.

f. Cold weather applications may require special techniques. Contact your local Tremco representative for advice.

Pressure Bar Systems:

a. When tape glazing a pressure bar system, a compression glazing system should be employed. POLYshim II Tape should be used.

b. It is important that the pressure bar is designed to fasten to a positive stop position. When properly installed, the pressure bar should provide a glazing pocket opening appropriate for the glass, tape and gasket being used.

c. Pressure bar systems that do not provide for a positive stop, may allow over compression of the tape. Over compression of the tape may result in glass breakage or poor performance of the system.

Slope Glazing:

a. When tape glazing skylights or other sloped systems, only POLYshim II tape should be used at the interior side of the lite. Non-shimmed tapes will not perform properly when subjected to the dead load of the lite.



b. When tapes are used with a pressure bar or glazing cap at the exterior of the lite, POLYshim II Tape or 440 Tape may be specified as appropriate for the system. Such systems must provide a positive stop for the glazing cap to prevent over compression or under compression of the tape.

- Plastic sheet into a steel sash is nearly 4 times that of glass.
- Plastic sheet into wood is 4-1/2 times that of glass.

Clearly, the choice of sash and infill have a great impact on the performance of the glazing seal.

b. While there are no hard and fast rules that govern the use of preformed tape sealants in plastic glazing, the following guidelines can be used to trigger the need to upgrade to a higher performance sealant system.

For Glazing Plastic Sheet Into An Aluminum Sash;

• For lites up to 36" (.92m) effective long dimension, POLYshim II Tape and 440 Tape may be used. A rule of thumb for sizing the tape is to specify 1/16" (1.57mm) of face Clearance for every 12" to 18" (304mm to 457mm) of effective long dimension.

The use of POLYshim II Tape and 440 Tape requires at minimum, proper compression of the tape and a gunnable sealant bead around each corner.

• For lites 36" to 72" (.92m to 1.8m) effective long dimension, a high performance gunnable sealant cap bead should be specified. This may be installed over POLYshim II Tape, 440 Tape or other suitable spacer that is recessed 3/16" (4.78mm) below the sight line.

The face clearance is determined from the anticipated shear movement and the movement capability of the specified gunnable sealant.

• As the effective long dimension exceeds 48" (1.2m), the required face clearance may no longer be practical for glazing with tapes or gunnable sealants. As this occurs, a metal system that will accept extruded rubber gaskets should be considered. This is especially true at 60" (1.5m) and greater.

• Over 72" (1.8m) effective long dimension, generally, only extruded rubber gaskets are practical. Metal systems must be designed specifically to engage gaskets and allow for water drainage.

Please keep in mind that the above information was developed to aid in decision making and does not constitute a set of rules.

Tape Size Selection Chart				
Glazing Type	Designed or pre-set Gasket Face Clearance	440 Tape	POLYshim II Tape Tape Shim Diameter	
Compression (PolyWej Gasket) Glazing	1/8"	Not Recommended	0.150" x 3/8"	1/8"
	3/16"	Not Recommended	0.215" x 3/8"	3/16"
	1/4"	Not Recommended	0.280" x 3/8"	1/4"
Non Compression Spacer or Wet Glazing	1/16"	1/16" x 1/2"	*Not Available	-
	1/8"	1/8" x 1/2"	0.125" x 3/8"	1/16"
	3/16"	3/16" x 1/2"	*0.188" x 3/8"	1/8"
	1/4"	1/4" x 1/2"	*0.250" x 3/8"	3/16"
*These sizes available by special order only. **0.090" x 3/8" w. 1/16" shim may be acceptable for special applications.				

Glazing of Plastic Sheet:

a. Referencing glass glazed into an aluminum frame as the standard condition, we must consider the following comparisons;

- Plastic sheet glazed into aluminum experiences 3 times the shear movement as will glass.



TREMCO INCORPORATED
Sealant/Weatherproofing Division

3735 Green Road • Beachwood, Ohio • 44122 • Phone: (216) 292-5000 • (800) 321-7906
220 Wicksteed Avenue • Toronto, ON M4H 1G7 • Phone: (416) 421-3300 • (800) 363-3213
1451 Jacobson Avenue • Ashland, Ohio • 44805 • Phone: (800) 321-6357 • Fax (419) 289-6645

An RPM Company