

LMRC-210 Series Digital On/Off/0-10 Volt Dimming Room Controllers

Plenum-rated controllers with line voltage relay(s) and 0-10 volt dimming output(s)

120/277 volt and 347 volt models

Plug to other components using Cat 5e cables with RJ45 connectors eliminating wiring errors

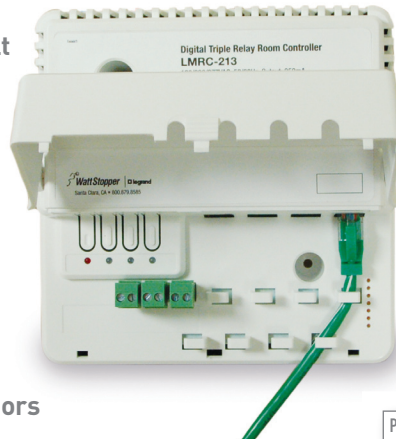

Plug n' Go automatic configuration for maximum energy efficiency

Store load preset level and 16 scene preset levels for each load

Support energy saving manual-on, bi-level, tri-level and dimming control strategies

PROJECT

LOCATION/TYPE

Product Overview

Description
LMRC-210 Series Digital Room Controllers include one, two or three relay(s) to switch a total of 15 or 20 amps, a high-efficiency switching power supply and one 0-10 volt output per relay for control of dimmable loads including electronic ballasts (Advance Mark 7, or equivalent). They are the foundation of a WattStopper Digital Lighting Management (DLM) system, and allow integration of occupancy sensors, daylighting controls and switches for energy-efficient lighting control.

Operation
LMRC-210 Series Room Controllers operate on one 120 or 277 volt, 20 amp, or 347 volt, 15 amp, feed and provide Class 2 power to sensors and switches via the DLM local network. Once powered up, Plug n' Go automatically configures system components for the most energy-efficient operation. The room controllers then dim or switch lighting or motor loads in response to input from the communicating devices. When a dimming input is received, the relay switches on when the dimmed level rises above zero, and off when it reaches zero, to coordinate control of power and the 0-10 volt signal to the load. They also monitor the current draw of the total connected load. Each room controller stores up to 16 scene preset levels for each dimmed output.

Features

- Plug n' Go™ automatic configuration for quick installation and maximum energy savings
- Push n' Learn™ functionality for personalization without the need for tools or a PC
- Digital Lighting Management components plug together on a free-topology Cat 5e DLM local network
- On/Off/Dim local override button for each load
- LED indicates status of each load
- Integral current monitoring of total connected load
- Optional lamp burn in; 12 or 100 hours
- 4 RJ45 ports with integral strain relief
- Zero-crossing circuitry for each relay for reliability and increased product life
- UL 2043 plenum rated
- RoHS compliant
- Qualifies for ARRA-funded public works projects

Plug n' Go Automatic Configuration

DLM room controllers manage Plug n' Go automatic system configuration, which establishes functionality based on the installed components. When room controllers are connected only to occupancy sensors, the system defaults to automatic on/off operation. If a wall switch is added to a system with one load, the load defaults to manual-on/automatic-off operation. If there is a wall switch and multiple loads, load one turns on automatically, while additional loads default to manual-on control; all loads turn off automatically. At system startup, default dimming parameters are established including: levels for scene presets 1-4; fade times; and fade and ramp rates. Dimming and system parameters may be customized using Push n' Learn.

Applications

LMRC-210 Series Room Controllers are ideal for single or multiple zone on/off or dimming lighting control applications. They are appropriate for applications in private offices, open offices, conference rooms and classrooms in any commercial building. LMRC-210 Series Room Controllers also help facility managers who want to track building power usage by monitoring current for lighting or other loads. A network bridge (LMBC-300) is required to expose DLM local network power data readings to a Segment Manager or BAS.



Specifications

- Voltage: 120/277VAC or 347VAC; 50/60Hz
- Maximum 20A combined load per Room Controller; each relay rated for:
 - @120/277V, 20A ballast or incandescent or 1Hp motor load; @347V, 15A ballast only
- Class 2 dimming control signal: 0-10VDC, sinks up to 100mA per channel for control of compatible ballasts (50 if each sources 2mA)
- Class 2 output to DLM local network: 24VDC, up to 250mA across 4 RJ45 ports
- DLM local network parameters:
 - Maximum current: 800mA
 - Category 5e cable, up to 1,000'
 - Up to 64 loads
 - Up to 48 communicating devices
 - Maximum 4 LMRC-100 Series Room Controllers
- Operating conditions: for indoor use only;
 - @120/277V: 32-158°F (0-70°C), @347V 32-140°F (0-60°C); 5-95% RH, non-condensing
- UL (88T9) and cUL listed
- FCC part 15 compliant
- Five year warranty

Controls & Mounting

Controls and Dimensions

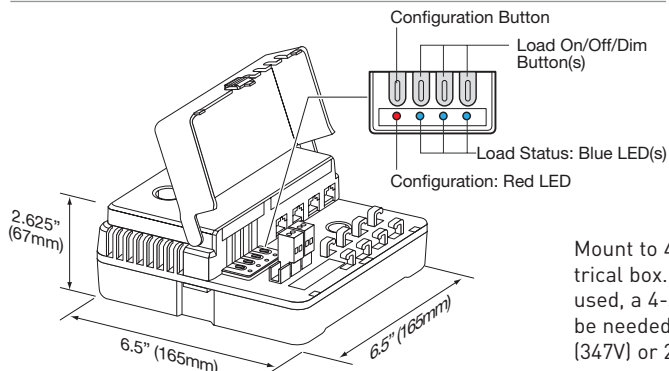

Mounting and Wiring

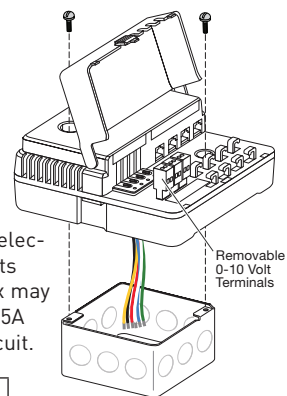

Mount to 4" x 4" x 2 1/8" deep electrical box. Depending on outputs used, a 4-square extension box may be needed. Connect to single 15A (347V) or 20A (120 or 277V) circuit.

Load Parameter (for each dimmed output)	Default Setting	Available Options
High trim	100%	1-100%
Low trim	0%	0-99%
Preset level: Scenes 1-16	1: 100%, 2: 75%, 3: 50%, 4: 25%, 5-16: 100%	all: 0-100%
Preset fade time	2 seconds	0 seconds -18 hours
Lamp burn in time	0	0, 12 or 100 hours

Connecting

Sample Connection Diagram with Dimming Switches and Scene Control

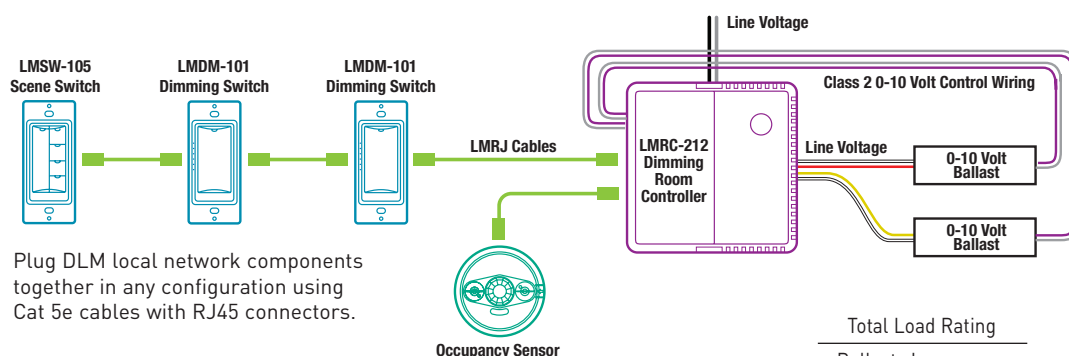

Plug DLM local network components together in any configuration using Cat 5e cables with RJ45 connectors.

Ordering Information

Catalog No.	Description	Voltage	Total Load Rating			Class 2 Outputs
			Ballast (A)	Incan (A)	Motor	
<input type="checkbox"/> LMRC-211	1 Relay Room Controller, 0-10V dimming	120/277VAC	20	20	1 Hp	24VDC, 250mA and 0-10VDC
<input type="checkbox"/> LMRC-211-U	1 Relay Room Controller, 0-10V dimming, ARRA compliant*					
<input type="checkbox"/> LMRC-211-347	1 Relay Room Controller, 0-10V dimming	347VAC only	15	-	-	
<input type="checkbox"/> LMRC-212	2 Relay Room Controller, 0-10V dimming	120/277VAC	20	20	1 Hp	
<input type="checkbox"/> LMRC-212-U	2 Relay Room Controller, 0-10V dimming, ARRA compliant*					
<input type="checkbox"/> LMRC-212-347	2 Relay Room Controller, 0-10V dimming	347VAC only	15	-	-	
<input type="checkbox"/> LMRC-213	3 Relay Room Controller, 0-10V dimming	120/277VAC	20	20	1 Hp	
<input type="checkbox"/> LMRC-213-U	3 Relay Room Controller, 0-10V dimming, ARRA compliant*					
<input type="checkbox"/> LMRC-213-347	3 Relay Room Controller, 0-10V dimming	347VAC only	15	-	-	
<input type="checkbox"/> LMRC-CA	Conduit Adapter for Low Voltage Connections					

*Product produced in the U.S.