



Architectural Concrete Pavers & Accessories

- Specification & Installation Information
- ADA Installation Guide
- Nine Paver Types



NEW Lok-Down System



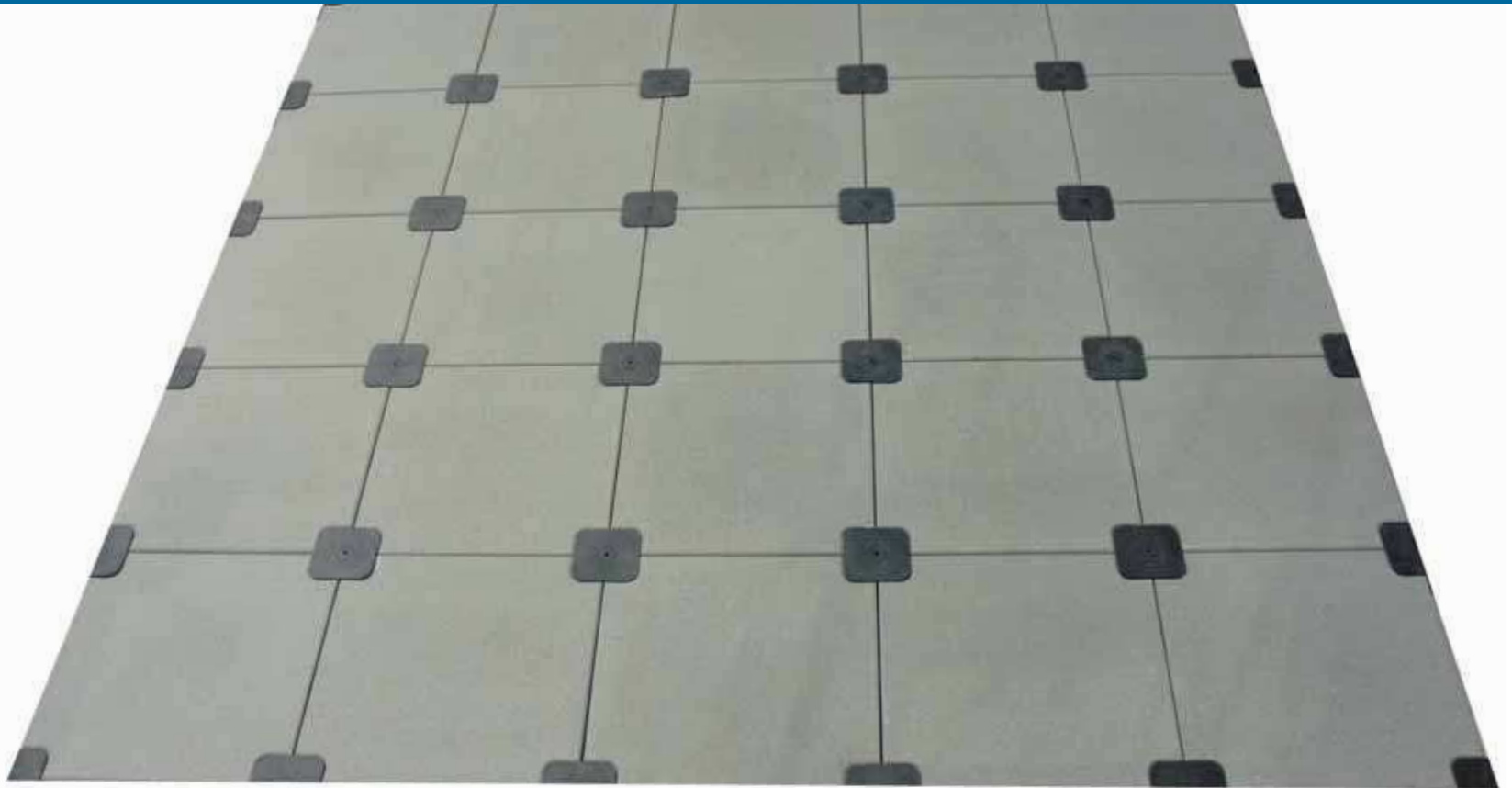

INTRODUCING

THE LOK-DOWN SYSTEM

BY WAUSAU TILE

- The new Lok-Down is specifically designed to resist wind uplift on paver roof deck installations
 - Allows for precise alignment using Wausau Tile pavers
 - Performance tested
 - Four components include:
 1. Cover with crown design for added strength
 2. Screw for easy removal of paver
 3. Paver with recess to maintain monolithic deck
 4. Base with grooves for drainage and spacer for alignment

Available in six standard colors

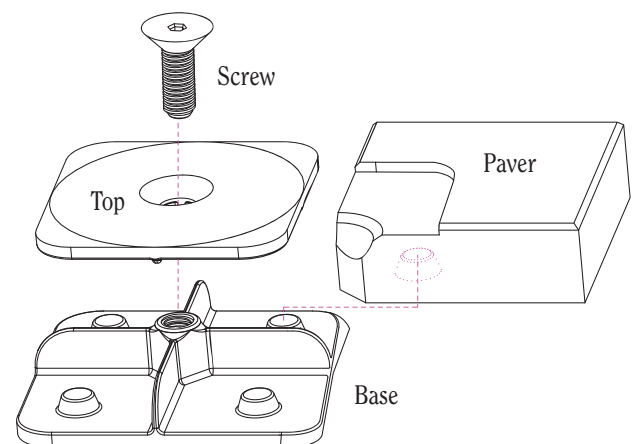

Colors and Finishes

TYPE 1 Exposed (Direct washed surface)

Natural stone in aggregate sizes of 3/8" to 5/8" is exposed at the surface. Nine standard colors are available by blending the aggregate colors with the matrix color tones; custom colors are available as an option. Available up to 36".



TYPE 2 Exposed Granite Aggregate (Direct washed surface)

Six colors are achieved by blending crushed granite in sizes of 3/16" to 9/16" with complementing colored matrixes; custom colors are available as an option. Available up to 36".

Type 2 Series A



Please call for color options and samples

Custom colors available upon request

TYPE 2 Granitex
(Direct washed surface)

Custom-sized granite aggregates in 3/16" minus sizes are blended in different matrix colors to give a uniform-dense surface. Twelve standard GTX colors are available. Manufacturing custom colors to match or blend with natural granite is our speciality. Available in sizes up to 36".

Type 2
Series A



Please call for color options and samples

*** Stocked in 24" Sized Pavers**

Type 2 Series B

Granitex
(Direct washed surface)



GTX1216



GTX1616



GTX2416



GTX2486



GTX2556



GTX3126



GTX3726



GTX4416



GTX7136



GTX7216



GTX7386



GTX7416



GTX7716



GTX7916



GTX8226



GTX8416

Terra-Pavers Product Summary

Standard Sizes (Nominal): 12", 16", 18", 24", 30" and 36" square
 Rectangular Sizes also available
 Thickness: 2" to 2 3/4" - Weight: 24 to 33 lbs./sq. ft.
 Dimensional Tolerance: +/- 1/16" (Length, width, height, convex, concave)
Custom sizes and thicknesses are available upon request.

Warranty: 3 year standard. Extended warranty available.
 Contact Wausau Tile for full warranty information.



GTX9216



GTX9326

Terra-Pavers Physical Properties

Property	Value	Test Method	Property	Value	Test Method
Compressive Strength	=>8,000 psi avg.	ASTM C140	Freeze-Thaw	=< 0.5% loss of dry weight (50 cycles)	ASTM C67
Flexural Strength	=>700 psi	ASTM C293	Center Load	1,850 lbs.	WTCL 99
Water Absorption	<6%	ASTM C140			

TYPE 3 Cotillion FDX

(Shot-blasted surface)

FDX colors are made by coloring the cement matrix with standard-sized aggregate. Six standard colors are available with the option of custom colors. Sizes up to 36".

Type 3 Series A

* FDX2008



* FDX4008



* FDX7008



FDX3008



* FDX1009



* FDX5008



TYPE 3 Cotillion SX

(Shot-blasted surface)

SX colors are a combination of granite and stone blended with colored matrix. Consistency in color is achieved by the exposure of aggregate in the paver surface. Custom colors are available in sizes up to 36".

Type 3 Series A

* SX2418



SX3418



SX4418



* SX7418



SX1419



SX5418



Please call for color options and samples

* Stocked in 24" Sized Pavers

TYPE 3 Fabritex
(Texture pattern surface)

Fabritex surfaces are available in slate, flagstone, travertine, sand, broomed and wood-grained finishes. All surfaces can be produced in our standard or custom colors in sizes up to 36".

**Type 3
Series B**



BR4008



TRV7008

FL6008

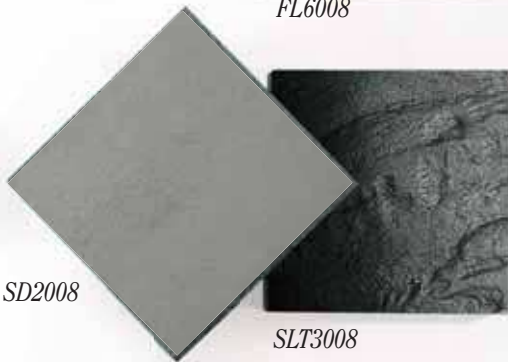

SD2008

SLT3008



WD5008

Terra-Paver colors and finishes shown are only a representation of the actual colors. Request samples for approved colors and finishes.

Please call for color options and samples

* Stocked in 24" Sized Pavers

TYPE 4 Stoney Creek

(Natural mottled color blended on stone textured surface)

Available in a ten-color spectrum that can be blended to give a wide range of color within the family. This natural stone appearance, in which no two pavers have the exact same color, can also be made in custom colors.

Available in sizes up to 36". Factory sealed.



* SC7779

SC7782



* SC7509

SC7569



* SC2228

SC2728



SC7869

SC7662



SLT/SC3519



SC4303

TYPE 5 Ground Pavers (With 5/8" aggregate)

Available with a ground, shot blast and sealed finish. Eighteen standard colors; also custom colors. Nominal sizes: 12", 16", 18" and 24".



BP1105 - Type 5A



BP1110 - Type 5A



BP1315 - Type 5A

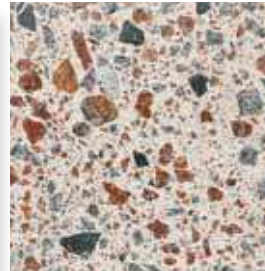

BP1425 - Type 5A

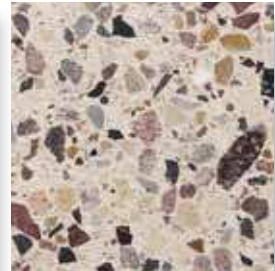

BP1475 - Type 5A



BP1503 - Type 5B



BP2105 - Type 5A

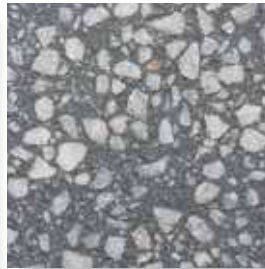

BP3105 - Type 5B

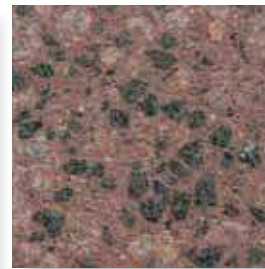

BP4105 - Type 5A

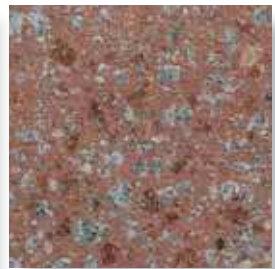

BP4215 - Type 5A



BP4345 - Type 5A

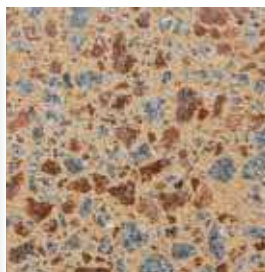

BP5105 - Type 5A



BP6625 - Type 5A



BP7105 - Type 5A



BP7755 - Type 5A



BP8415 - Type 5A

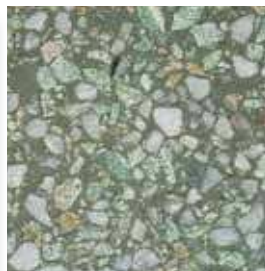

BP9105 - Type 5B



BP9905 - Type 5B

Please call for color options and samples

TYPE 6 Cool Pavers

Cool Pavers have a minimum of 72% solar reflectance (SRI) absorbing less heat than a standard ballast material on roof decks. The pavers will maintain a minimum of 50% reflectivity in a three-year period. Cool Pavers are available in eight colors and six different textures. The same sizes and thicknesses as our standard pavers are also available in the Cool Pavers. Available up to 36”.



Bright White



Carous



Forest Light



Hemp



Mimosa



Pandora

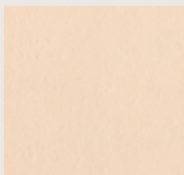

Pleasant



Skyline Blue



Snow White



Softness

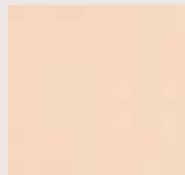

Ultra Tan

TYPE 6 Solar White

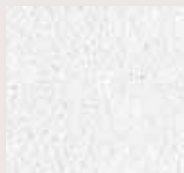

CPX1119



CPX1999



You've got our guarantee that any product with this logo meets Energy Star ratings.

Meet SRI of 78

TYPE 7 Ocean View Pavers

This beautiful series of pavers will give your design a look and feel like no other paver, while maintaining the same quality you have come to expect. Available in sizes up to 24”. The seashell pavers have a ground and blasted finish.

Shell Series

Coral Series

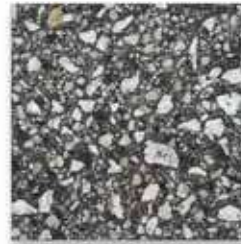

OVGRB0003



OV1025

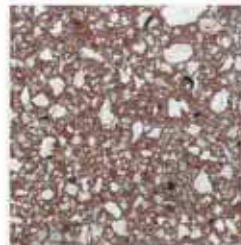

OVGRB0004



OV5005



OVGRB0007



OV5085

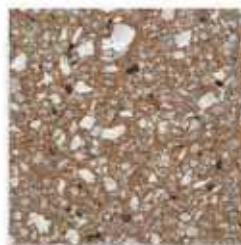

OVGRB0008



OV6075

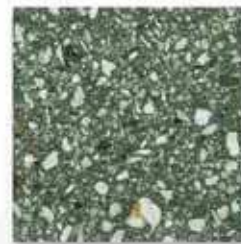

OVGRB0009



OV8455

Glass Pavers

Our pavers are manufactured with 100% recycled glass and available in a wide variety of colors. Recycled Glass Pavers meet or exceed the ASTM industry standards for compressive strength, flexural strength, water absorption and freeze-thaw testing. Available in sizes up to 36".



TYPE 9 Glass Blasted Pavers

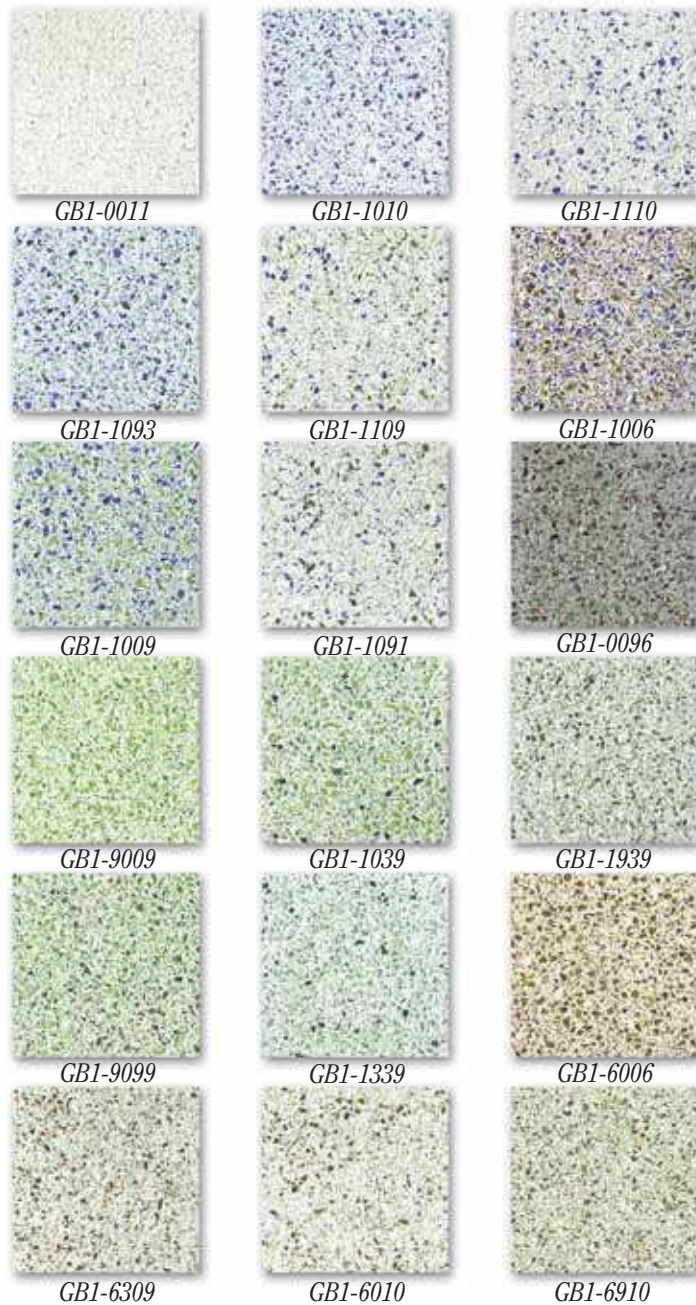

TYPE 8 Glass Washed Pavers

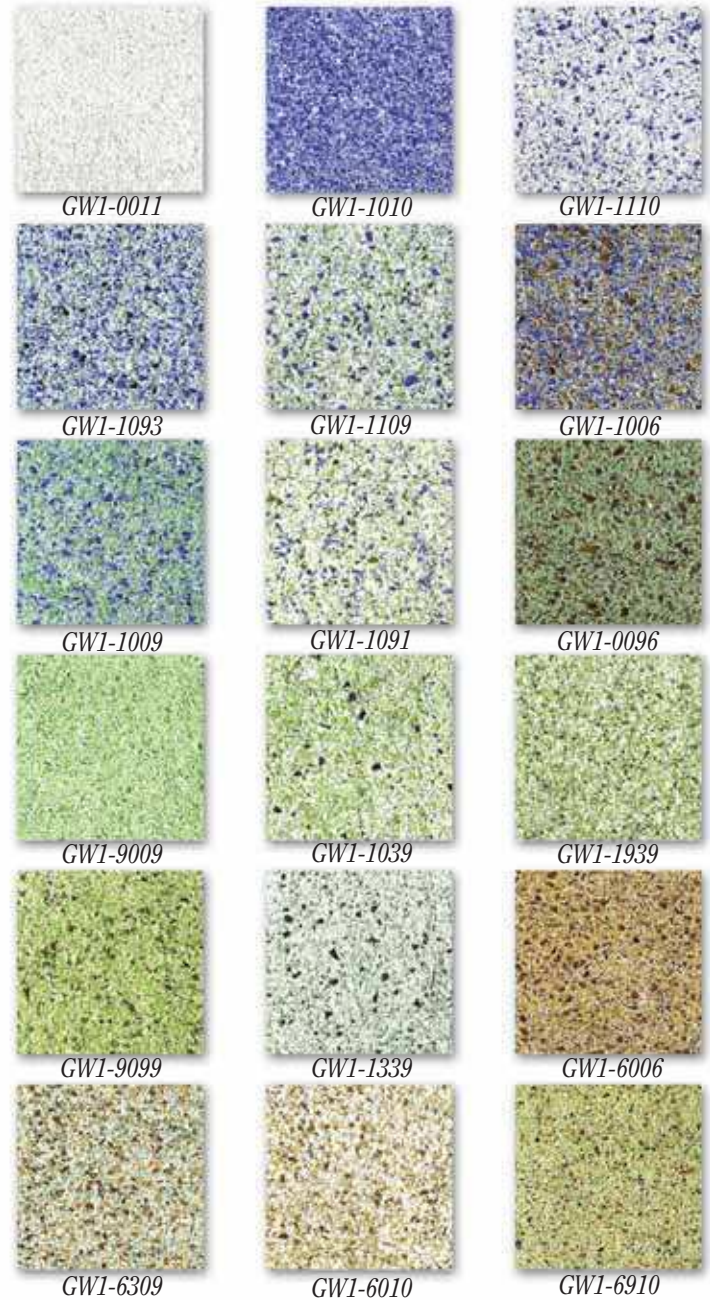

Recycled glass products from Wausau Tile qualify for Green Status and LEED certification.

Stoney Creek



Pre-designed Original Patterns

Save design time when you use our pre-designed Ashlar patterns. The pavers are available in nine architectural paving styles with five patterns to choose from. The hardest part will be choosing which style to use for your next project.

Please call for more information, or check us out on our web site, www.wausautile.com

Ashlar patterns available



WT1



WT2



WT3



WT4



WT5

Ballast Pavers 24" In stock

Get more information about our unique way to turn roofs and plazas into functional space with Terra-System One Roof Deck Systems in section 077200/WAU and 077600/WAU of Sweets.



FDB200

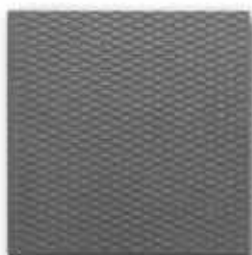

FDB354



FDB454



FDB554



FDB654

800.388.8728 / www.wausautile.com

Our textured pavers come in five standard patterns and 15 standard colors. Custom patterns, colors and sizes are available upon request.

Standard Colors

Stock Size = Nominal
12" and 24" Sq.

Stock Pavers

Standard Textures



ADA-1 Truncated Dome



** ADA-2 Truncated Dome



** ADA-3 Truncated Dome



Directional Bar (12" only)



Tactile Warning

*FDX5008

FDX7008

FDX2008

*FDX3008

*FDX1008

*FDX4008

*FDXSY7008

*Federal Yellow
33538
FY7008

** Stock Pattern

* Stock Color

*U5008

U7008

U2008

*U3008

*U1008

*U4008

*USY7008



ADA Paver Designs and Patterns

ADA-1 Staggered Pattern

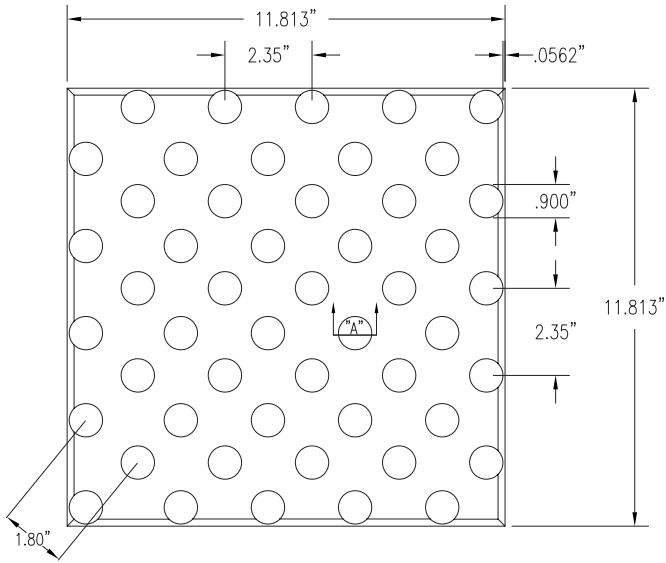

12" ADA-1 PAVER

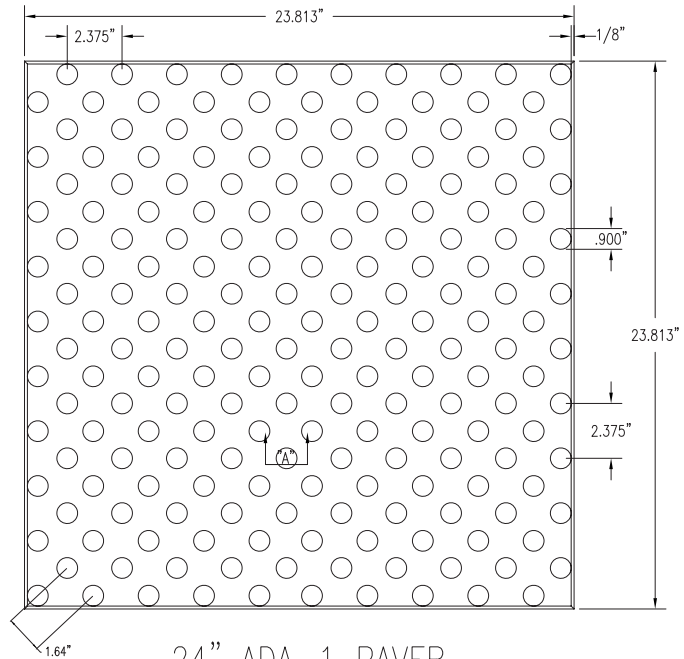

24" ADA-1 PAVER

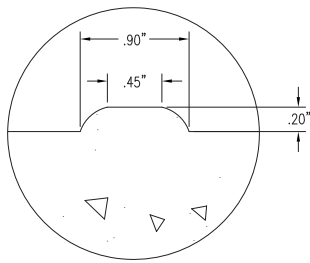

DETAIL 'A'
WARNING DOME DETAIL

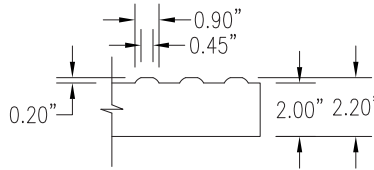

ADA-2 Straight Row 2.375" Spacing Pattern

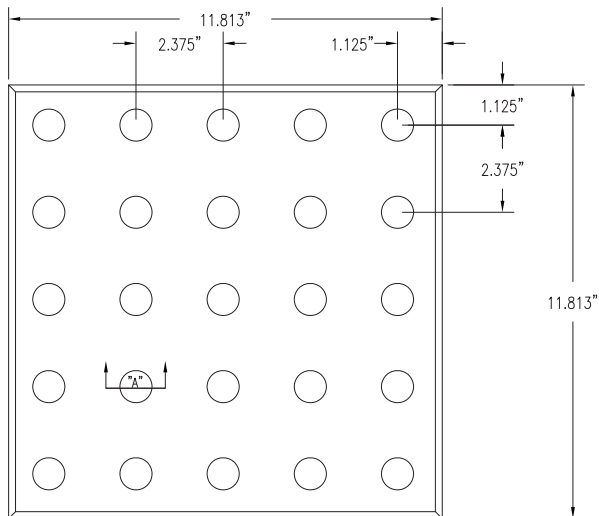

12" ADA-2 PAVER

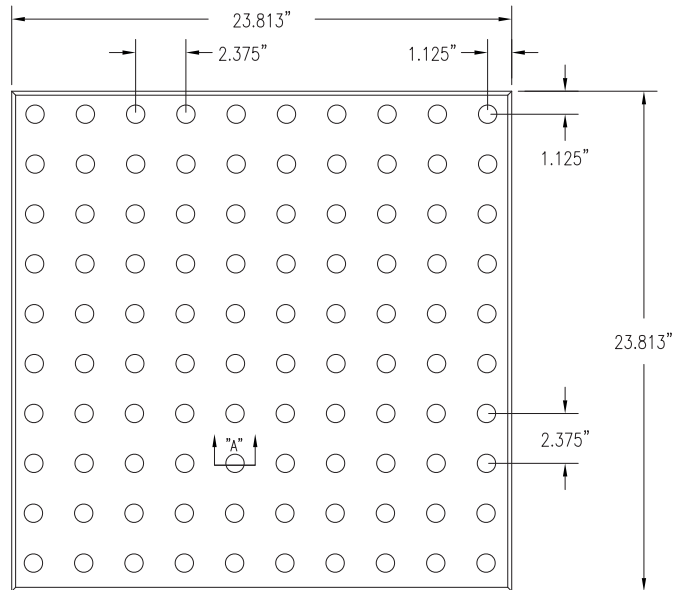

24" ADA-2 PAVER

ADA-3 Straight Row 1.67" Spacing Pattern

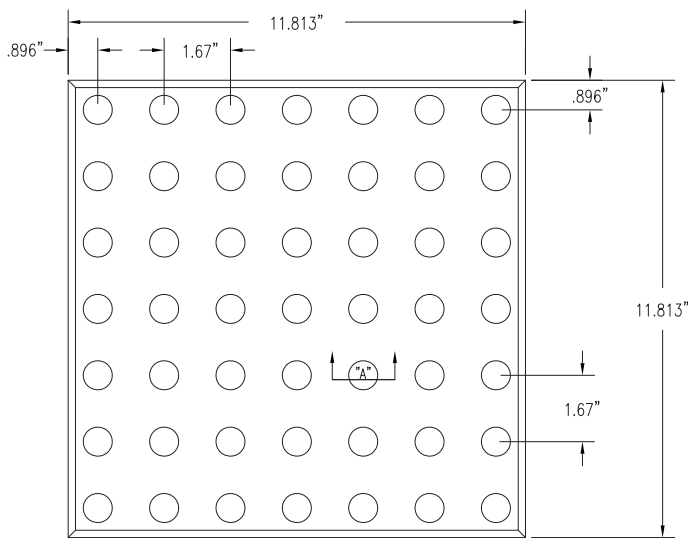

12" ADA-3 PAVER

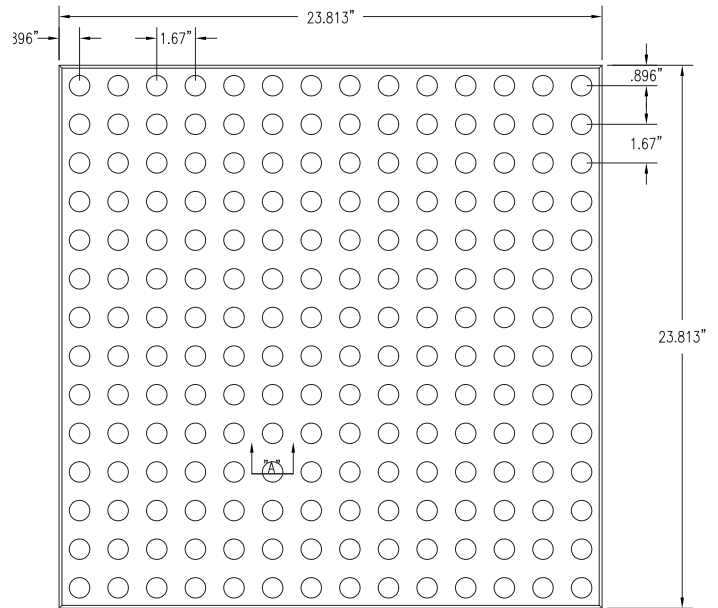

24" ADA-3 PAVER

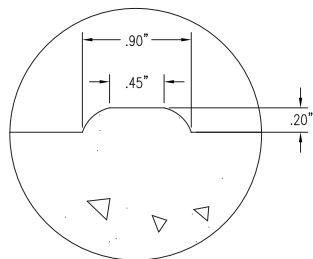

DETAIL 'A'
WARNING DOME DETAIL

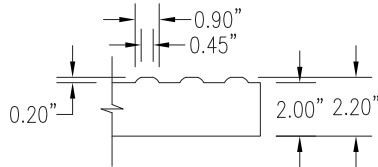

Directional Bar Pattern

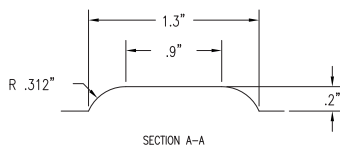
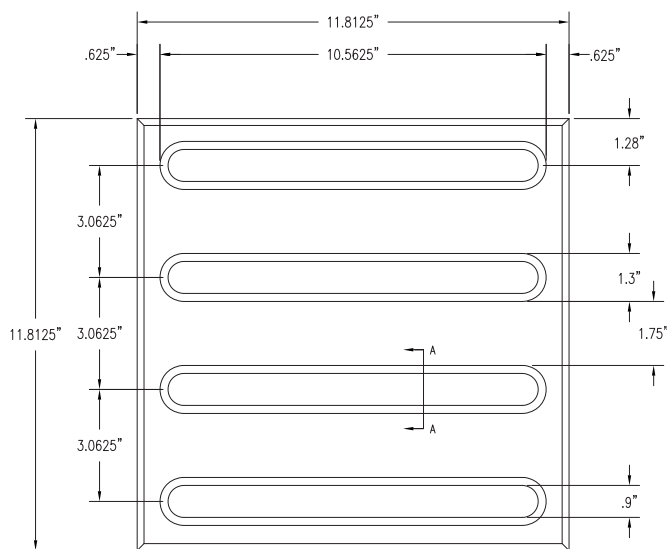

Tactile Warning Pattern

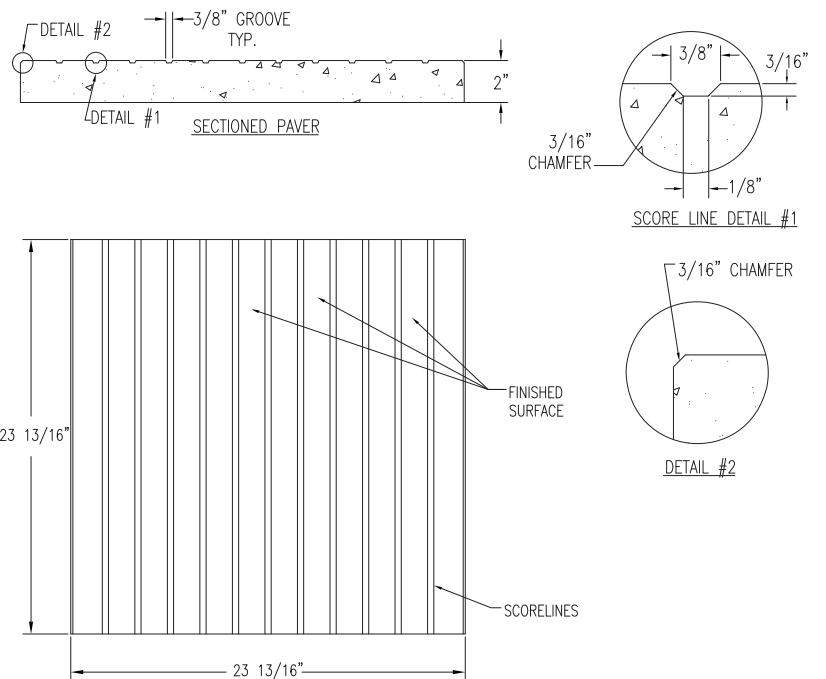

* Details available for download at www.wausaupaving.com

Typical ADA Installation

NEW

ADA PAVER INSTALLATION GUIDE WITH WAUSAU TILE'S REUSABLE BLOCK-OUT FRAME



1- Prepare area to receive concrete and ADA detectable pavers.



2- Drive in rebar to the approximate height to receive Wausau Tile's block-out frame. The framework has small feet to help locate where rebar should be located.



3- Set block-out frame so rebar sits inside the frame legs.



4- Set block-out frame to final grade by tapping on framework.



5- Pour concrete into and around framework. Level concrete and bull float area.



6- Level concrete with a straight edge inside of the framework adding concrete as needed. Note: Standard frame designed for 2" thick paver.



7- Pull out frame. Bull float area to receive ADA pavers.



8- Allow concrete to cure. Use the following guidelines based on installation method. Note: If using wet set, do not allow concrete to cure.

Typical ADA Installation

ADA Paver Guide For SAND SET Installation With Wausau Tiles Reusable Block-Out Frame



Step #1 - Sand Set Installation - Create weep holes for drainage. Core drill hole once concrete has set or, while concrete is still wet, make a hole with pipe.



Step #2 - Sand Set Installation - Add masonry sand to recessed area.



Step #3 - Sand Set Installation - Screed 1/4" masonry sand.



Step #4 - Sand Set Installation - Set pavers in sand. Leave 1/16" to 1/8" between units to allow for sand.



Step #5 - Sand Set Installation - Sweep sand into joints after installation.



Complete.



Main Block-Out Frame
24" x 36" \$125.00

Extension Block-Out Frame
12" x 24" \$75.00

12" Standard Blok-handle \$65.00



*Prices subject to change without notice

Typical ADA Installation

ADA PAVER GUIDE FOR **THIN SET** INSTALLATION WITH WAUSAU TILE'S REUSABLE BLOCK-OUT FRAME



Step #1 - **Thin Set** Installation - Apply thin set with 1/4" x 3/8" notched trowel. Exterior grade.



Step #2 - **Thin Set** Installation - Spread fully and evenly.



Step #3 - **Thin Set** Installation - Set pavers. Be sure pavers are fully set into thinset. (Back buttering may be necessary.)

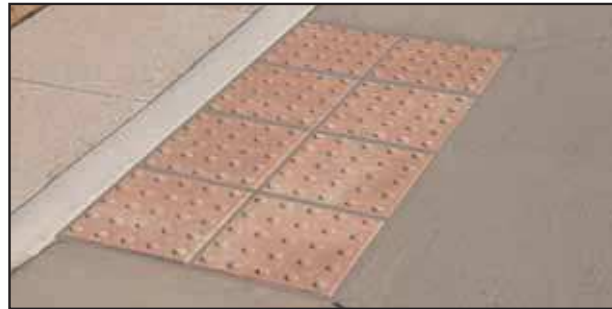

Step #4 - **Thin Set** Installation - Grout all joints with an exterior based grout. Complete.

ADA PAVER GUIDE FOR **WET SET** INSTALLATION WITH WAUSAU TILE'S REUSABLE BLOCK-OUT FRAME



Step #1 - **Wet Set** Installation - While concrete is still wet, inbed pavers into cavity.



Step #2 - **Wet Set** Installation - Level pavers by tapping with rubber hammer. Note: Joints may or may not be grouted; contractor option.



Complete.

Hex Pavers

Our new precast concrete Hex Pavers are available in a nominal 8" size. The thickness ranges from 2" to 2 3/4". The concrete hexagonal pavers are manufactured in shot-blasted finish, as well as in standard and custom blends.



Water Jet Pavers

- Distinguish your project from others
- Easy installation
- Able to cut intricate designs
- Cost effective
- Durable, high quality finish



Open Joint Installation

Terra System One Sloped Installation Method

Pedestrian use only

Terra System One Level Installation Method

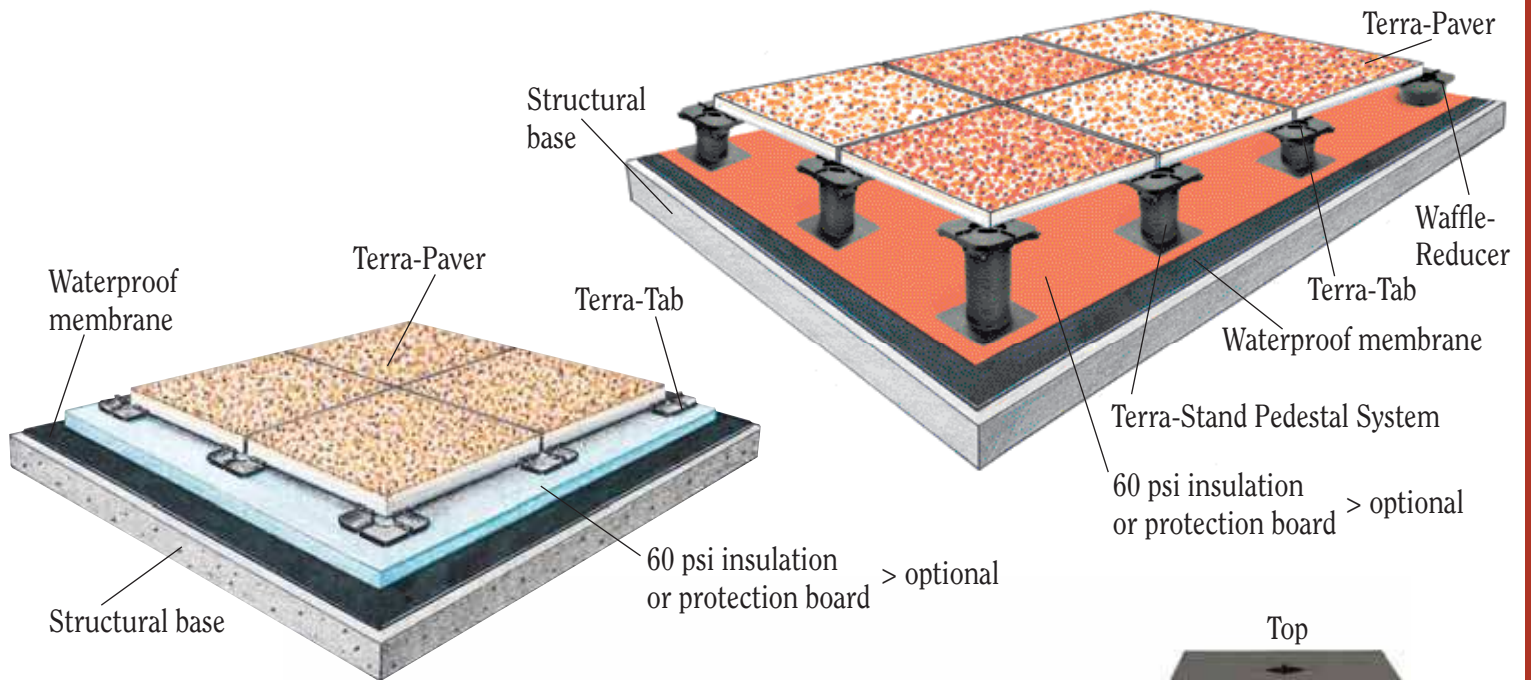

Terra-Stand

The Terra-Stand pedestal screws up and down from 2" to 21" in height and compensates for slope up to 5/8" per foot providing a level installation. The Terra-Stand allows for a maximum weight load of 3,000 lbs. per pedestal. Our Waffle-Reducer consists of a base with four rings for height adjustment between 1/2" and 2 1/8".



Los Angeles approval
#RR25699

Core Size from 5" to 20"



800.388.8728 / www.wausautile.com

Terr-Adjust Pedestal, Terra-Tabs and Terra-Shims

Rubber tabs and shims

are used on both systems as the contact between paver and pedestal, allowing for expansion joints, proper alignment and minimal sound transmission.

The Terr-Adjust pedestal telescopes from 2" to 5 1/2" in height and slope compensates up to 2" per foot to provide level installation. The reducers and extenders allow for system adjustment from 1/2" to 10" in height. Pedestals are filled on site with pre-blended concrete mix.

The Terra-Tabs and Terra-Shims are used in conjunction with the Reducers, Terr-Adjust and Terra-Stand Systems. If a level deck is not needed, Terra-Tabs can be used alone for quick and easy installation.

Terra-Tabs are available with 1/8" or 3/16" spacing.



Rubber parts made with 23% recycled material. 1/16" to 1/4"

Blok Handles

- Easier installation
- Labor cost savings
- Helps prevent back and hand injuries
- Can be ordered with your other Terra System One Accessories

Blok Handles aid in the installation or removal of Terra-Pavers. Use the standard Blok Handle for pavers up to 24", the Big Blok Handle or Back Saver for pavers 24" and larger.



Back Saver
\$1,300.00



Standard
\$65.00



Big Blok w/wheel attachment
\$200.00

Complete Unit
\$450.00



Big Blok
\$250.00

Prices subject to change without notice

Typical Architectural Details

Wall/Building Termination Using Terra-Stand

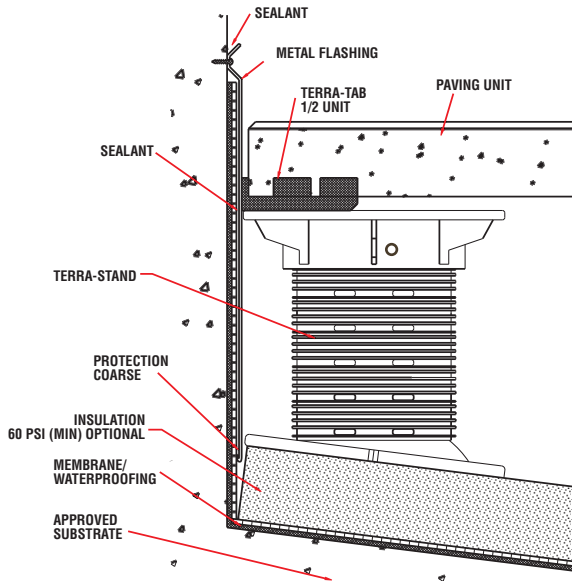

Wall/Building Termination Using Terra-Adjust

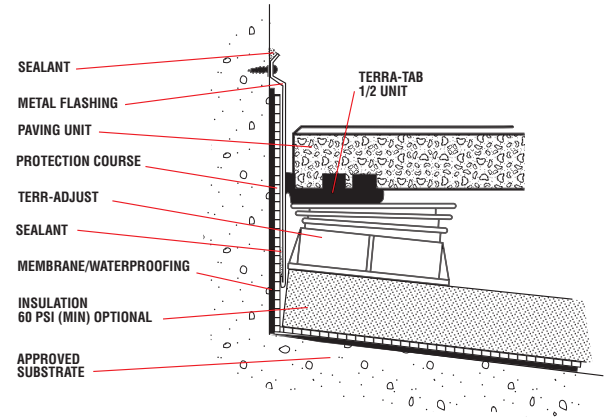

Paving Joint

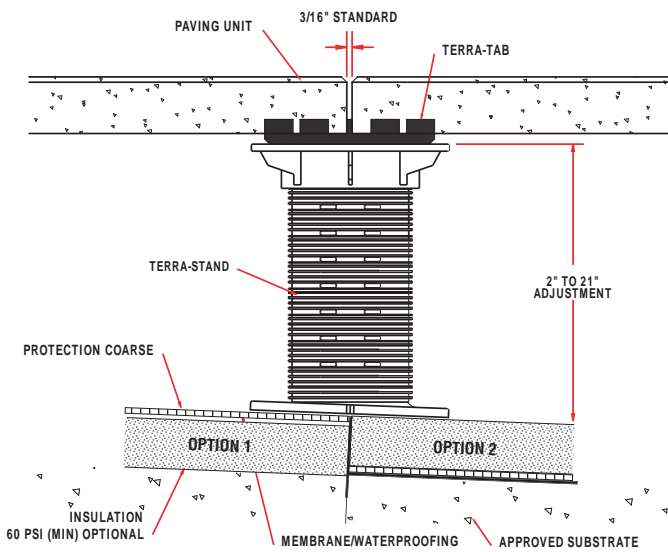

Wall/Building Termination

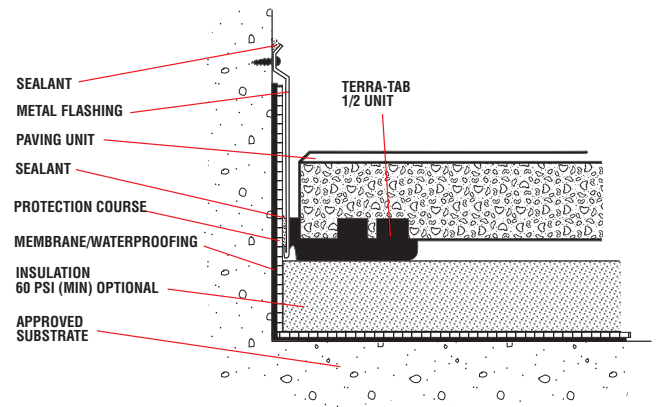

Paving Joint

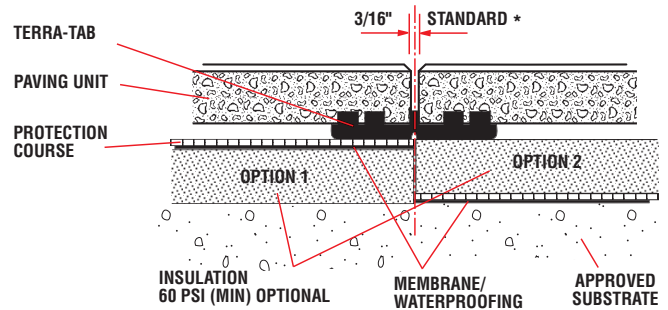

Los Angeles approval
#RR25699

* 1/8" JOINT OPTIONAL

Mortar Set Installation

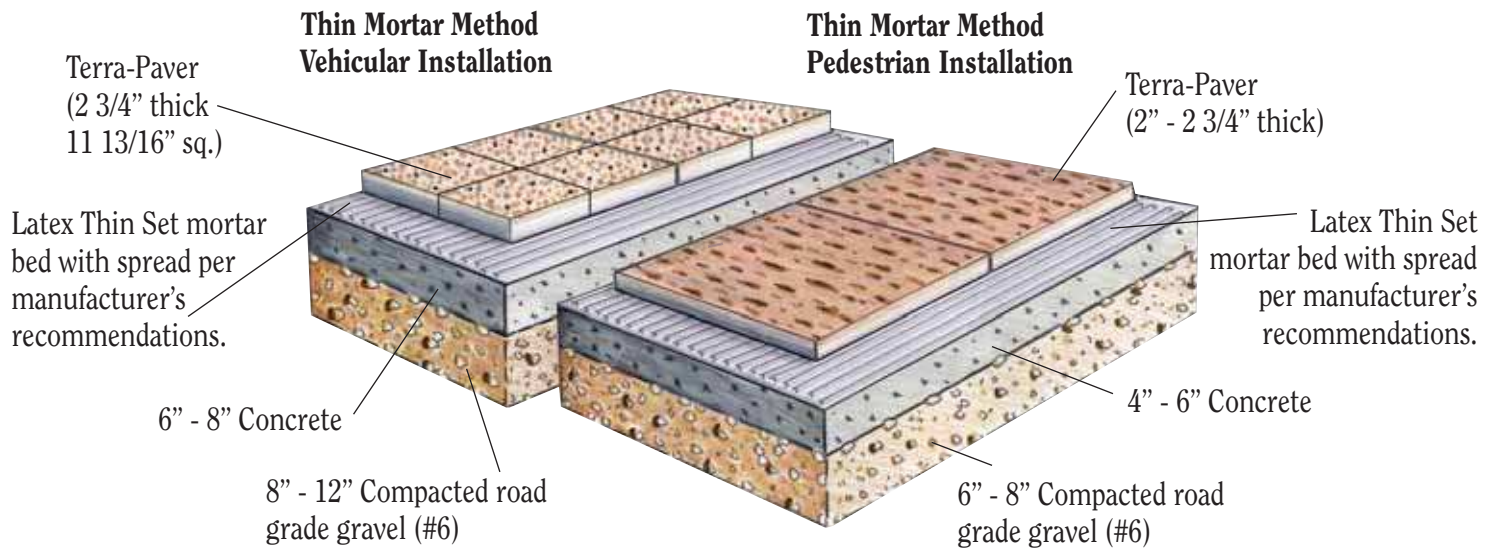

For vehicle use, select pavers that are 2 3/4" thick x 12" square.

For projects requiring a grouted look, mortar set installation may be used. Stability of the sub-base and concrete substructure is critical. The joints are grouted and all components (setting bed, grout and mortar) must be used with a latex or acrylic admixture for waterproofing. The use recommendations of the admixture manufacturer must be followed. Perimeter and interior expansion joints must be designed to allow for all movement in the installation.

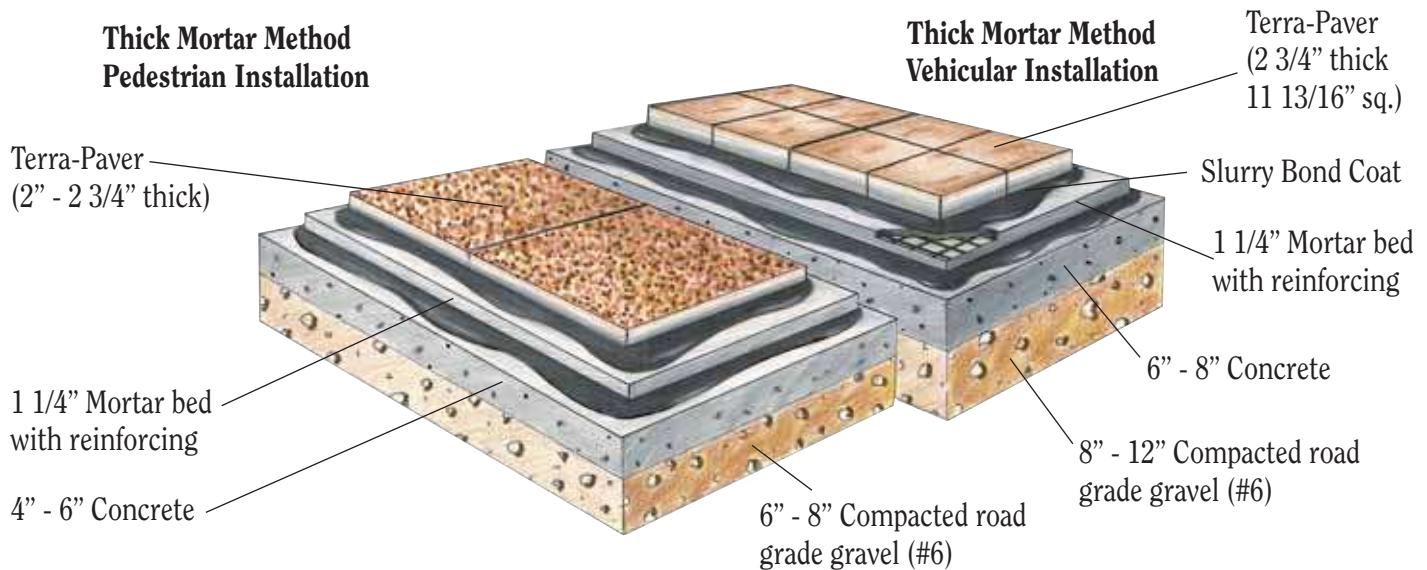

For vehicle use, select pavers that are 2 3/4" thick x 12" square.

*A 100% bond between Terra-Paver and setting bed is recommended. To achieve this, the "Back Butter" method and a 3/8" x 1/2" notched trowel should be used.

Sand Set Installation

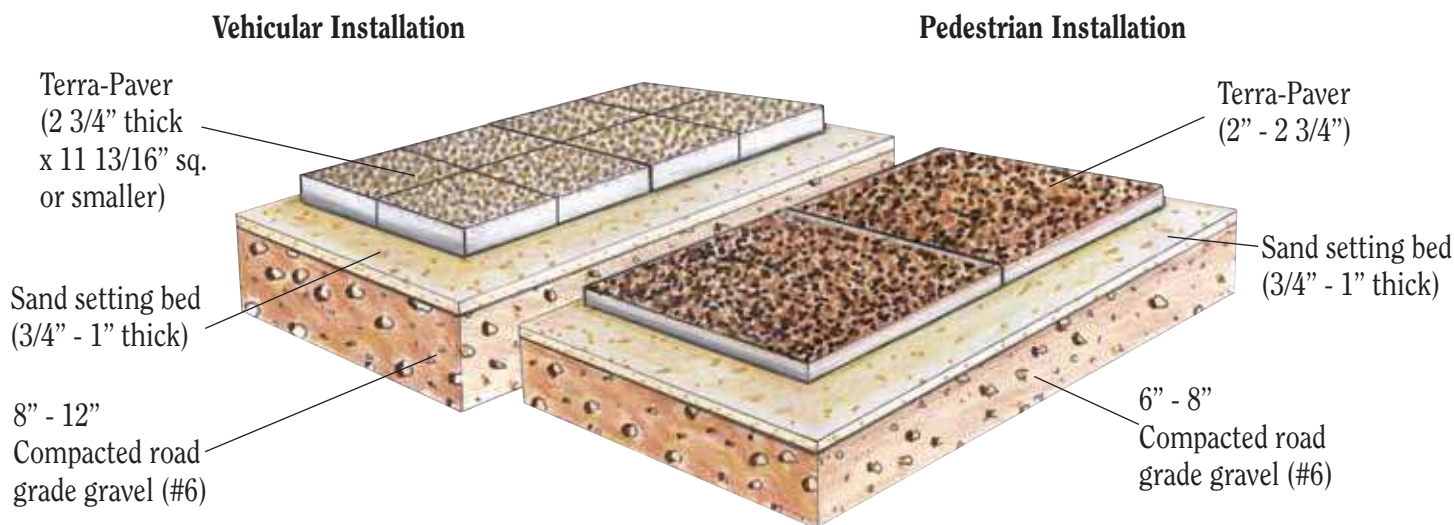

*For vehicle use, select pavers that are 2 3/4" thick x 12" square.
When Terra-Pavers are installed on inclines, the use of a filter cloth is recommended to stabilize the sand setting bed.*

In addition to being economical, the sand set method of installing Terra-Pavers allows for easy replacement, repair or adjustment of the pavers. Sand set installation can be utilized with soil conditions that drain well and are stable with no settling. Proper compaction of the sand setting bed and the road grade gravel sub-bed is critical to prevent settling and movement of the pavers after installation. For stability, the sand bed should be no thicker than 1". Joints should be 1/16" to 1/8" and swept with sand.

Bituminous Installation

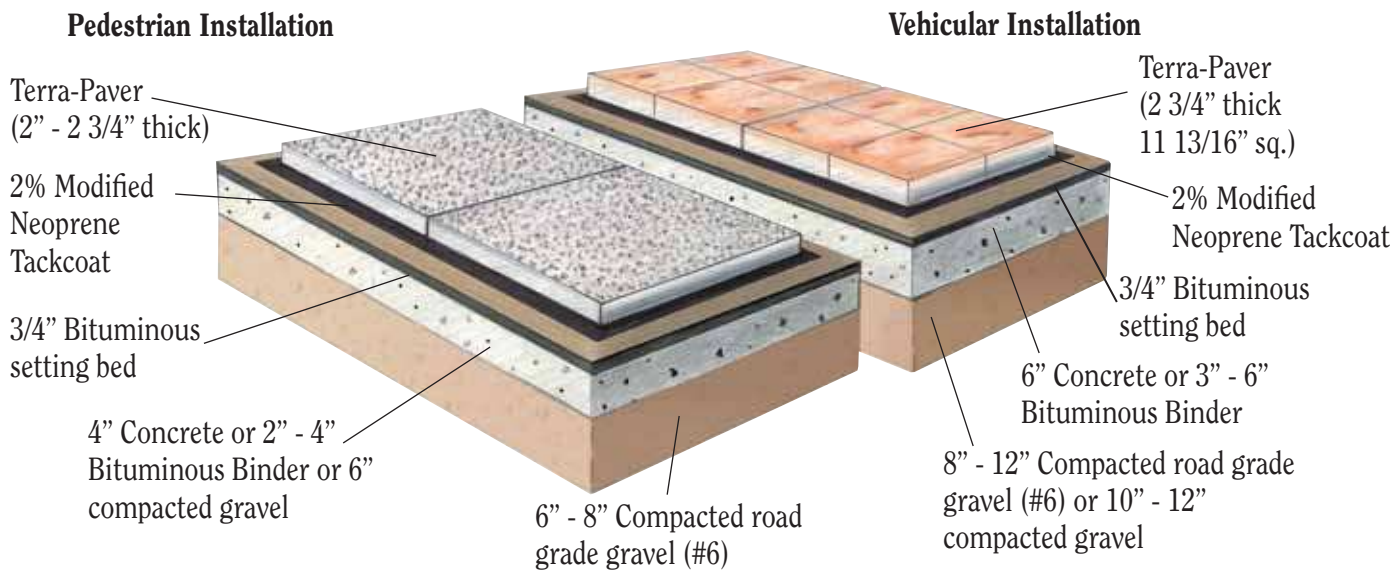

For vehicle use, select pavers that are 2 3/4" thick x 12" square.

In applications where stability is critical, Terra-Pavers may be installed using the bituminous method over compacted gravel, bituminous or concrete sub-bases. As with the sand set method, the subgrade must be stabilized to prevent settling. Bituminous setting beds thicker than 3/4" should be applied in multiple layers, each layer not to exceed 3/4" in thickness. Bituminous bed can be rolled in with 12" pavers or smaller only. Do not roll on pavers larger than 12". Installation of the Tackcoat should be done according to the manufacturer's instructions to assure proper bonding and to prevent water from getting underneath the pavers. Joints should be 1/16" to 1/8" and swept with sand.

WAUSAUTILE



PO Box 1520
Wausau, WI 54402-1520
800.388.8728
Fax: 715.359.7456
www.wausautile.com
www.wausaupaving.com
wtile@ausautile.com

PRESORT STD
U.S. POSTAGE
PAID
U.M.S.

Retrofit of a Plaza Deck

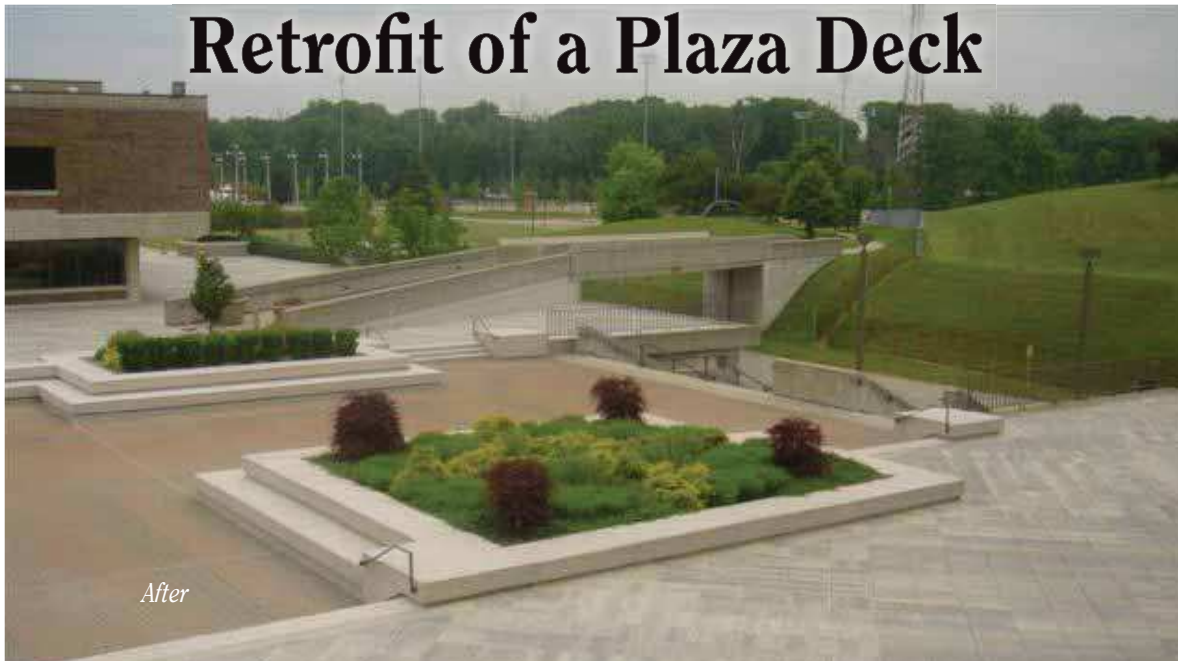

After

Before

Water entrapment is a major cause of failure in plaza decks.



*Project: City of Southfield, Michigan - Municipal Complex Plaza
Architect: Noreen Kozlowski
Installing Contractor: RAM Construction Services*

The completed retrofit resulted in a totally new plaza with patterns and colors to complement the existing buildings.

Terra System One is a cost-effective solution for failed roof and plaza decks, allowing removal of damaged areas, replacement of new sub-base, installation of a new membrane, protection material, and insulation. Steps, curbs, copings, planters, benches and other components are available to complete the project.

Mission Statement

Wausau Tile, founded in 1953, is dedicated to the principle of manufacturing the highest quality products while providing the best customer service in our industry.