

SLOTSEAL STD 2015-3

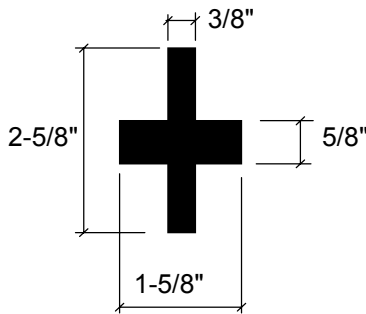

BLOCK SEAL 2018-3

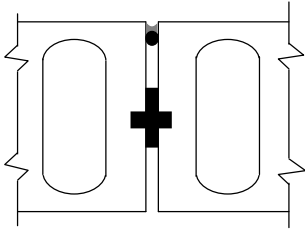
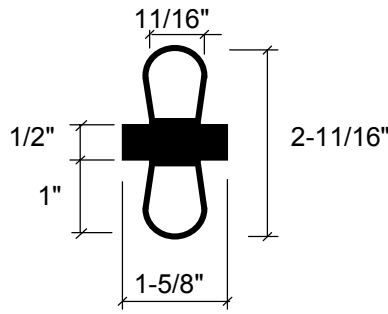
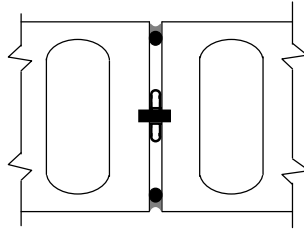

WEATHERTITE "R" 0318-3

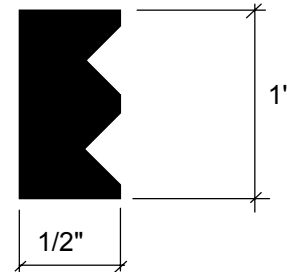
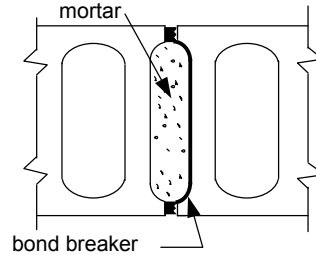

APPLICATIONS

Everlastic® Masonry Control materials are designed to prevent destructive cracking in masonry and prevent destructive cracking in masonry (from temperature and drying shrinkage, differential movement of structural members and surrounding masonry, settling of foundations, etc.). Williams' materials also seal out moisture and cold air at a reasonable price.

SLOT SEAL STANDARD 2015-3

A shear lug to provide shear control and vertical control for expansion/contraction of masonry walls. Manufactured of high grade synthetic rubber compounds.

Polymer: Blended EPDM/SBR/CR, AASHTO D-2000, 3BA810-80 Shore A Hardness, 1000 PSI tensile. Exceeds material standards of 2AA805 (80 hardness - 500 PSI tensile).

BLOCK SEAL 2018-3

For Sash Block

Hollow wings are easily compressed to provide pressure seals on each side of keyway in addition to shear control. Manufactured of high grade synthetic rubber compounds.

Polymer: Blended EPDM/SBR/CR, ASTM D-2000, 3BA810-80 Shore A hardness, 1000 PSI tensile. Exceeds material standards of 2AA805 (80 hardness - 500 PSI tensile).

WEATHERTITE "R" 0318-3

For Stretcher or Line Block (Michigan Control Joints)

A specially shaped, non-absorbent, expanded rubber strip seal. Weathertite "R" provides multiple, continuous, presser sealing surfaces. This closed cell material is impervious to water and possess high acoustical insulating properties.

Polymer: Neoprene grade ASTM D-1056, RE 41, SCE-41, 2A1.



To the best of our this published information is accurate, however, to determine suitability of material/product for a specific application is the user's responsibility. Williams Products, Inc. shall not be liable for any loss or damage resulting from inappropriate usage.

WILLIAMS PRODUCTS, INC.

1750 MAPLELAWN BOULEVARD - TROY MICHIGAN 48084 - PHONE (248) 643-6400 - TOLL FREE (800) 521-9594 - FAX (248) 643-7117

www.williamsproducts.net