

PERMA-TRENCH™

INSTALLATION INSTRUCTIONS

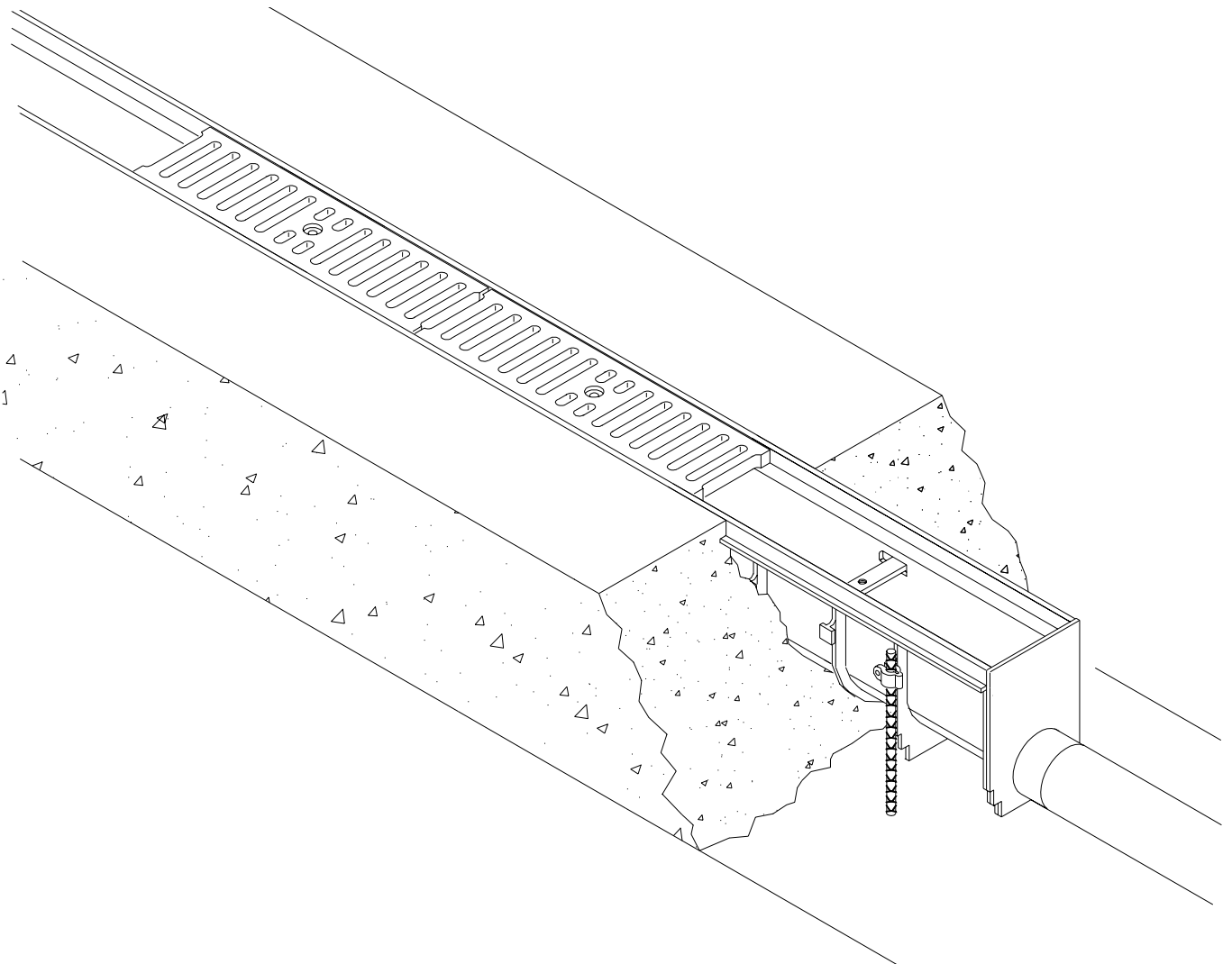

ZURN INDUSTRIES, INC. FLO-THRU DIVISION, 2855 Girls Road, Jamestown, NY 14701
Phone: 716.665.1132, Fax: 716.665.1135, World Wide Web: www.zurn.com

Form # FT535 Date: 6/28/00 C.N. No. 85132 Rev.

Perma Parts...

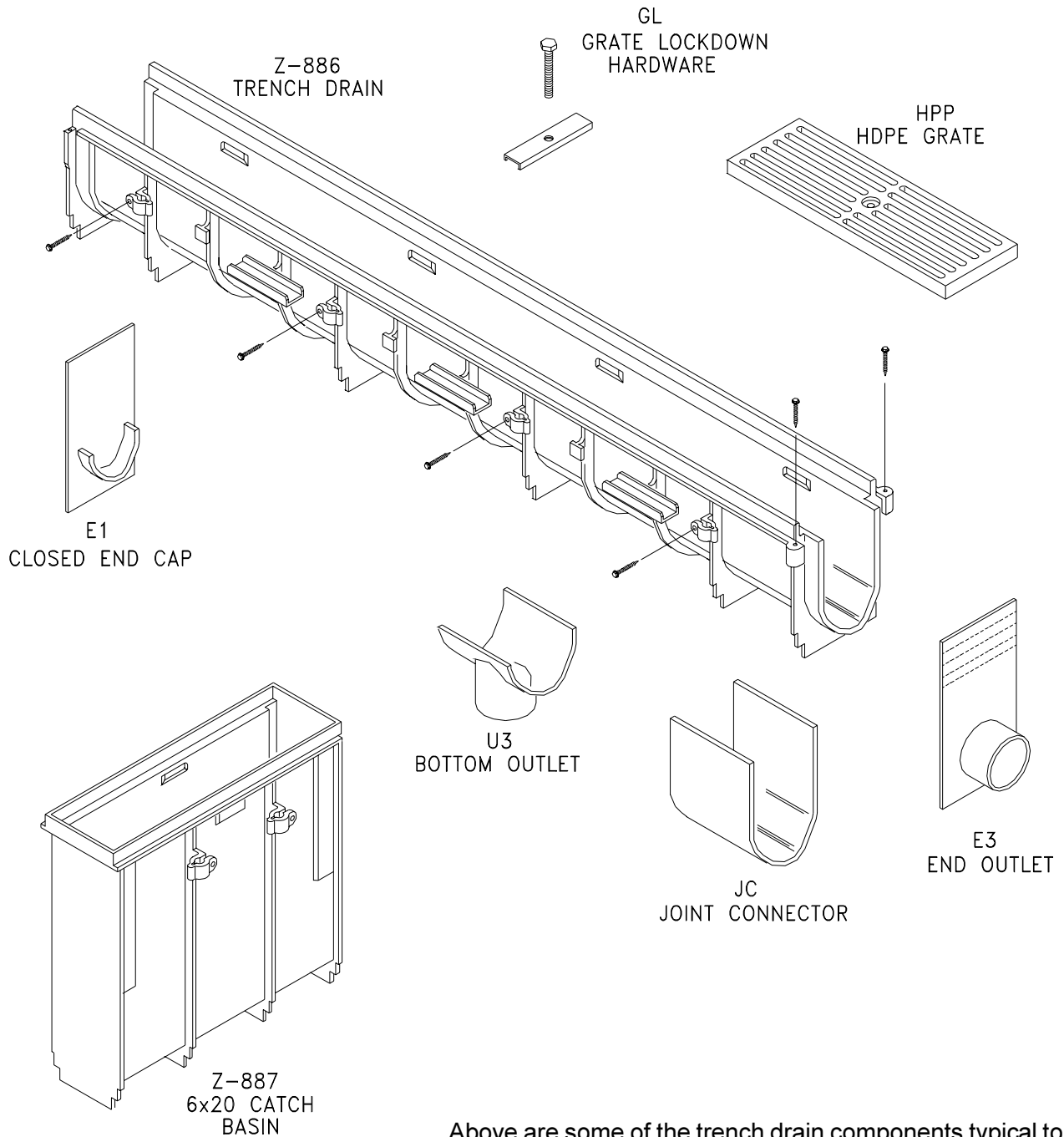

Above are some of the trench drain components typical to an installation. Double check your order to ensure that you have all components particular to your job before beginning your installation.

Contact Zurn 'Flo-Thru' at 716-665-1132 should additional material be required.

Outlets & Accessories

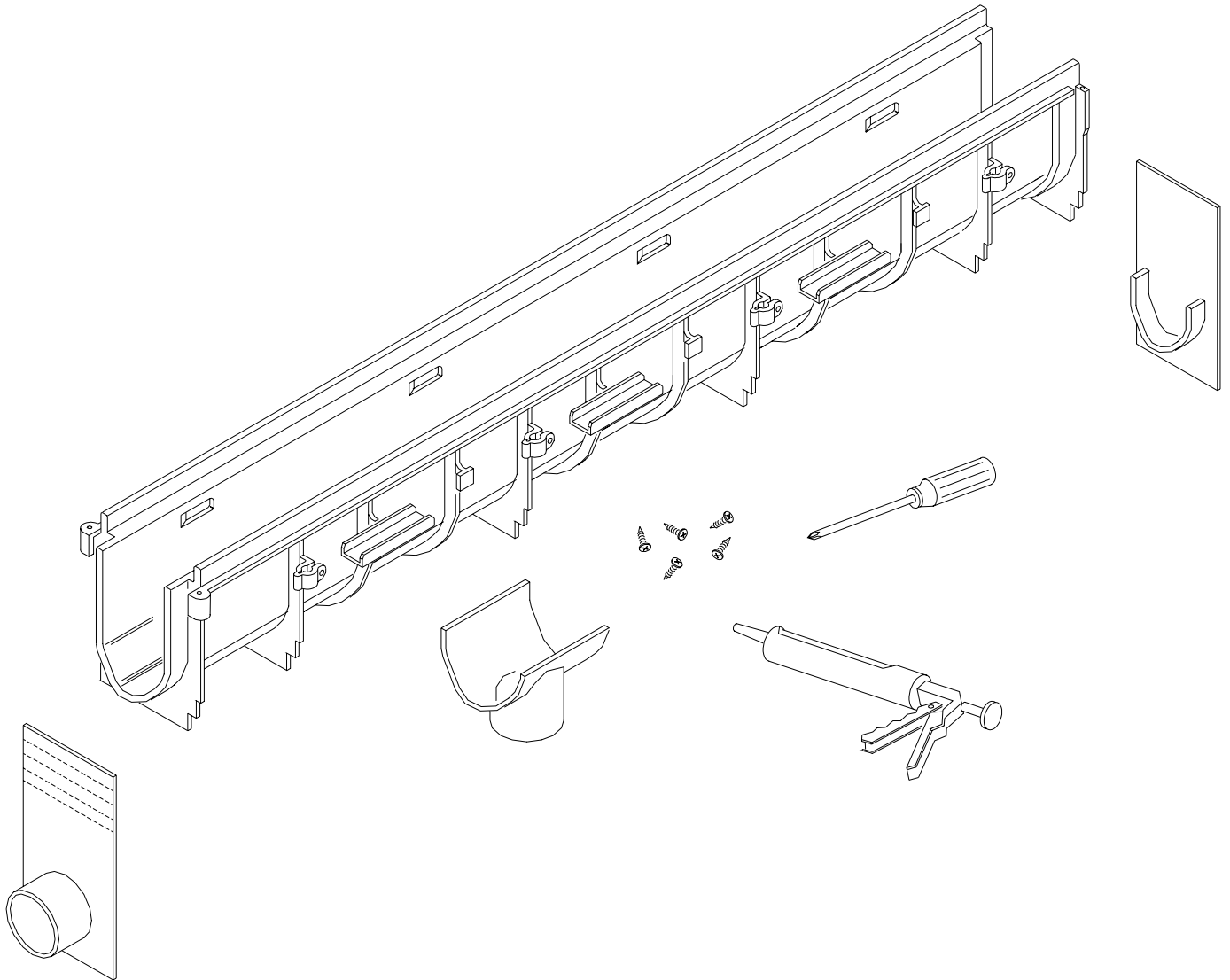

Locate the trench sections that are to receive any accessories, such as end caps, bottom outlets, and/or end outlets. These accessories can be easily attached with a silicon caulking and/or sheet metal screws. Trim the end caps to the appropriate depth prior to attaching them to the trench sections.

Outlets & Accessories cont'd

To attach an end outlet, remove the 1-1/4" male overlap portion of the trench as shown. Trim the end outlet to the appropriate height and attach with the hardware provided.

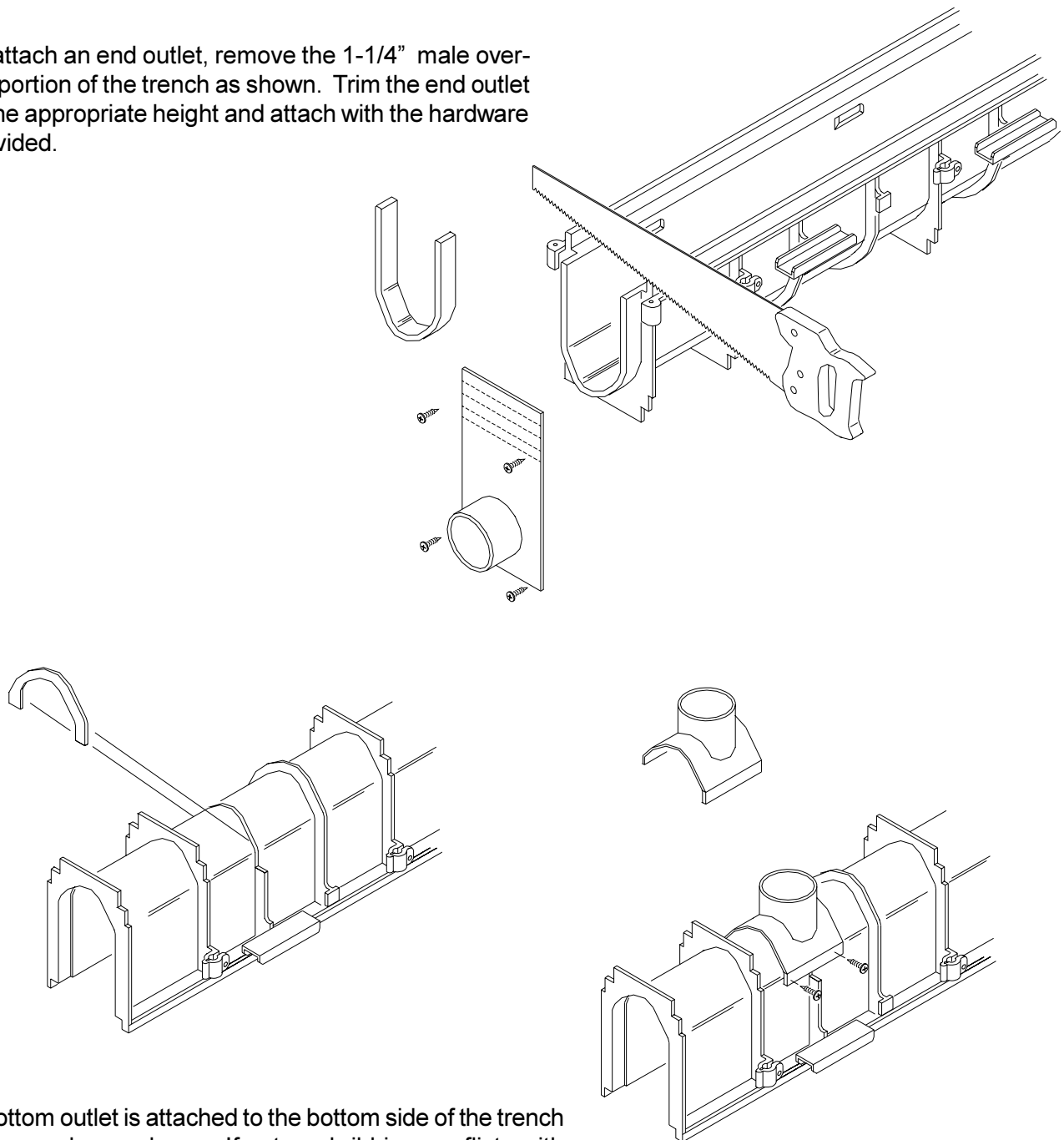

A bottom outlet is attached to the bottom side of the trench drain as shown above. If external ribbing conflicts with the location of the outlet, simply remove the ribbing with a reciprocating saw. A hole saw can be used to cut the appropriate size hole through the bottom of the trench. Attach the bottom outlet with the hardware provided.

Storage and Handling

The Perma-Trench sections are designed to stack upon themselves to ease handling and optimize space. Considerations must be made to stack the trench sections on a flat pallet as shown. Make certain that the shipping bars are in place and that the trench sections interlock with each other as shown. It is important that no foreign objects are allowed to lean on the trench sections since this can place undue stress on the components.

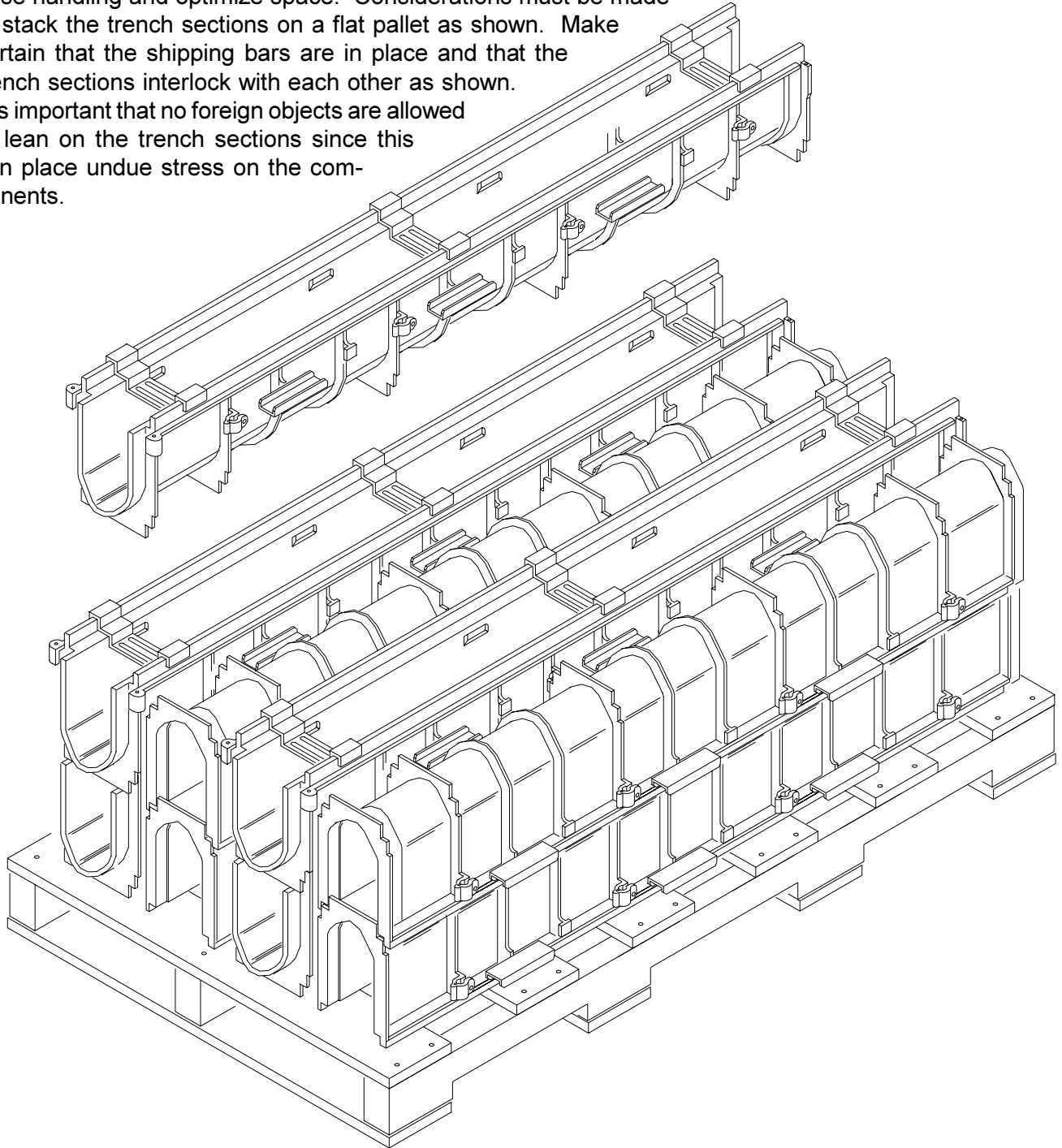

Frame Options

Perma-Trench offers a Heavy Duty (HD) frame option for intense traffic patterns. Simply slide the HD frame over the trench sections as shown below and attach with the hardware provided. Make certain that the notched end of the frame is at the male end of each trench section.

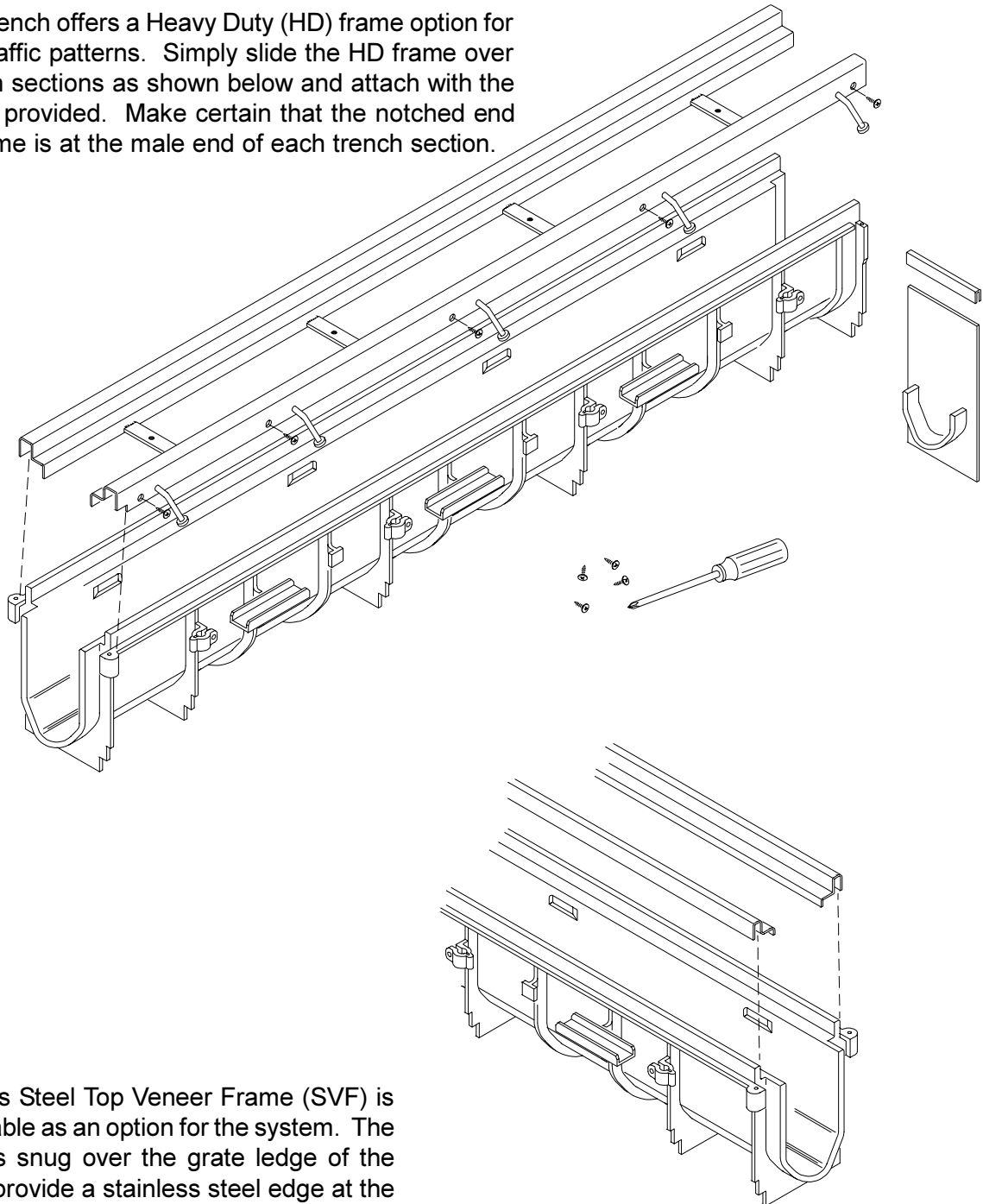

A Stainless Steel Top Veneer Frame (SVF) is also available as an option for the system. The veneer fits snug over the grate ledge of the trench to provide a stainless steel edge at the surface.

Excavation

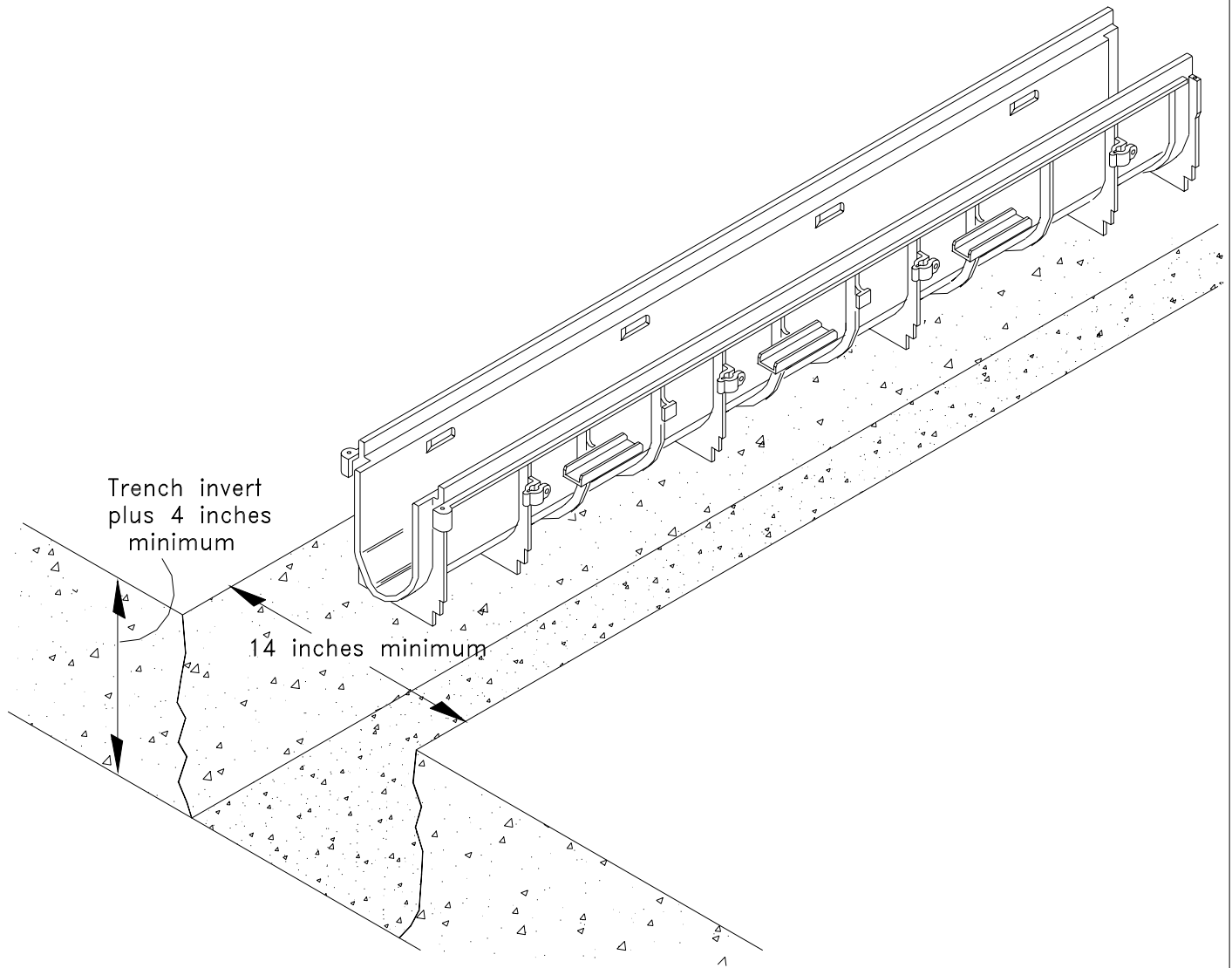
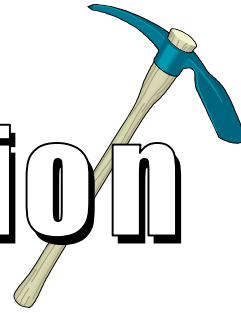

Trench excavation must be 4 inches greater than the trench depth and a minimum of 14 inches in width. Soft and/or shifting soil substrates may cause cracking of the concrete and consequent movement of the trench. It is critical that the concrete be poured on an adequate foundation.

Overall Layout

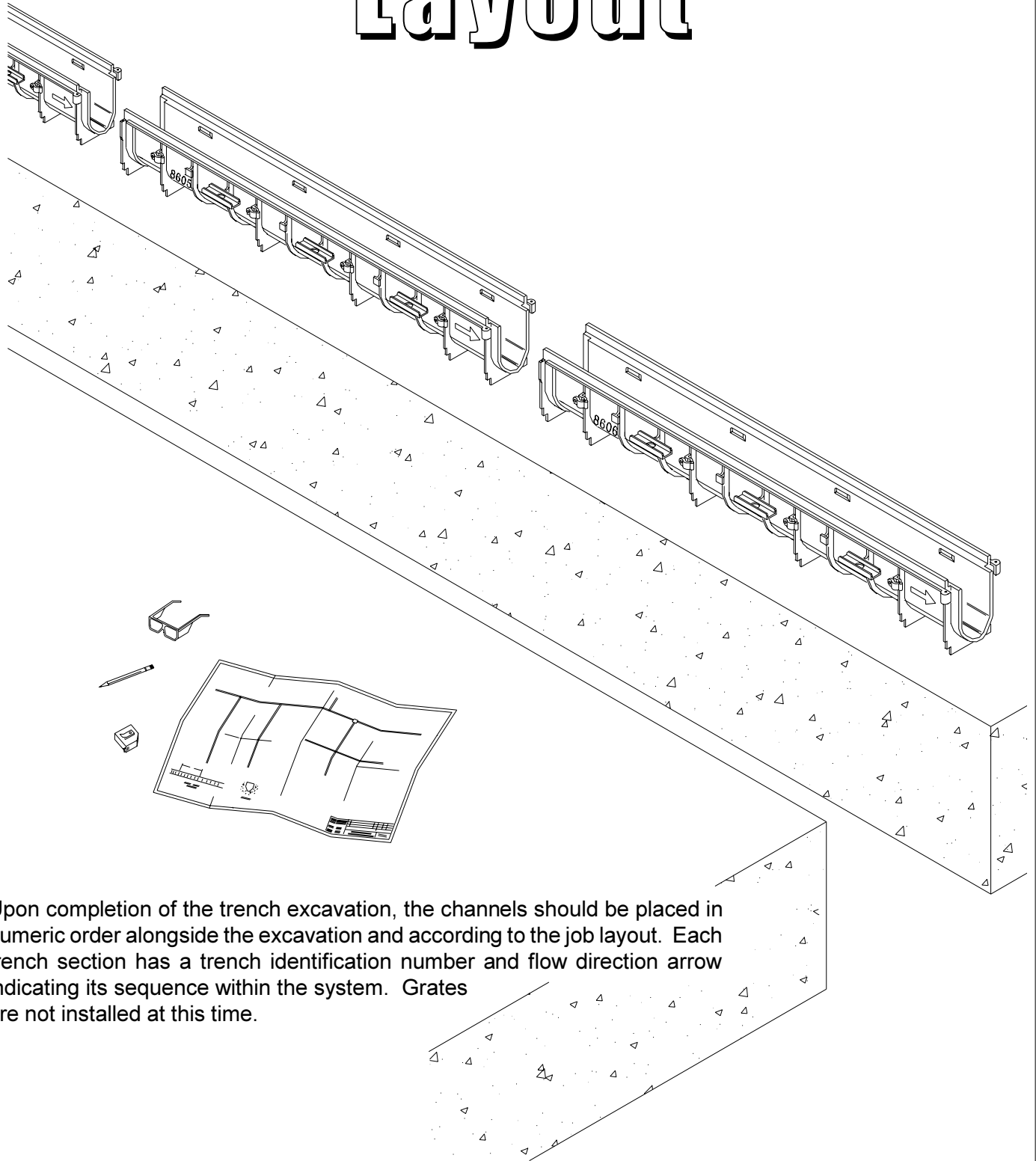

Upon completion of the trench excavation, the channels should be placed in numeric order alongside the excavation and according to the job layout. Each trench section has a trench identification number and flow direction arrow indicating its sequence within the system. Grates are not installed at this time.

Setting the trench

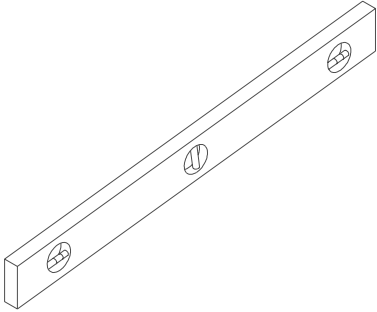

Typically, a trench system is assembled from the outlet on back. Starting with the deepest section or catch basin, set the first channel utilizing Perma-Trench's unique anchoring system. Integral rebar clips are located along the length of each trench drain and catch basin for easy attachment to #4 rebar stakes. Simply align the rebar stakes with the trench drain and drive them into the ground for positive anchoring. Attach the trench drain to the rebar stakes with the hardware provided.

Adjust the trench to the desired elevation and continue with the adjacent section.

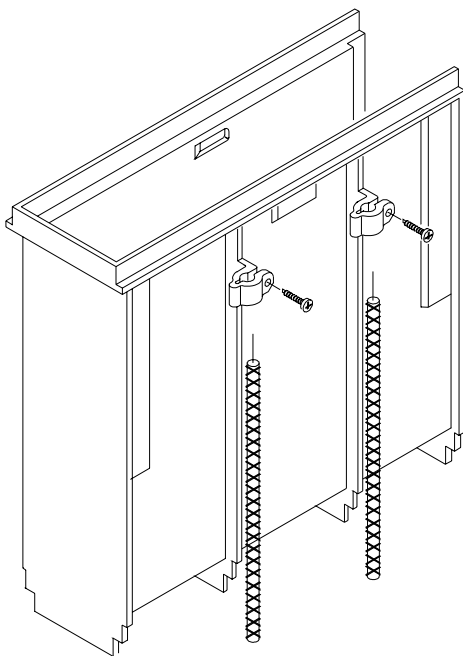
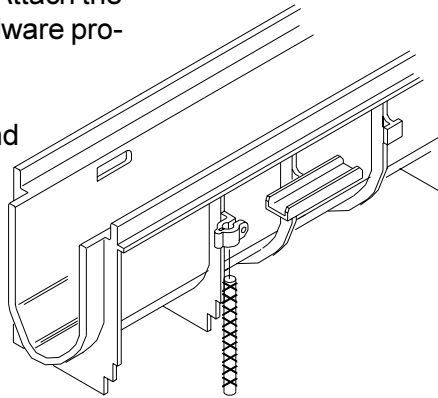
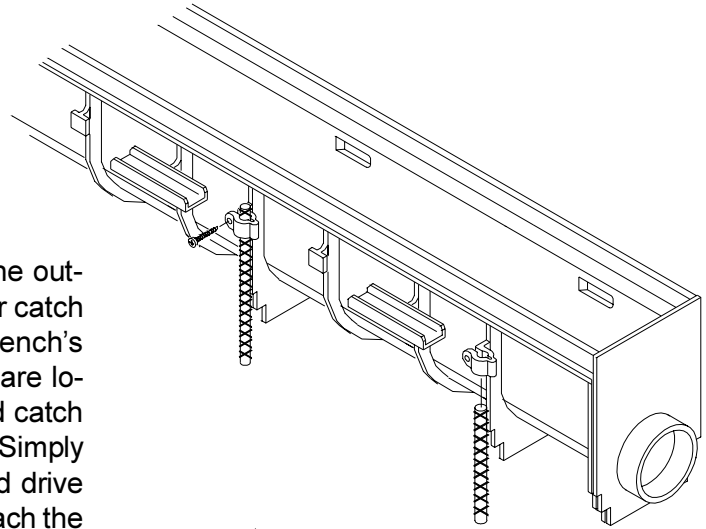

If a catch basin is included within your layout refer to step **13** for further details on catch basin preparation.

Suspended Installation

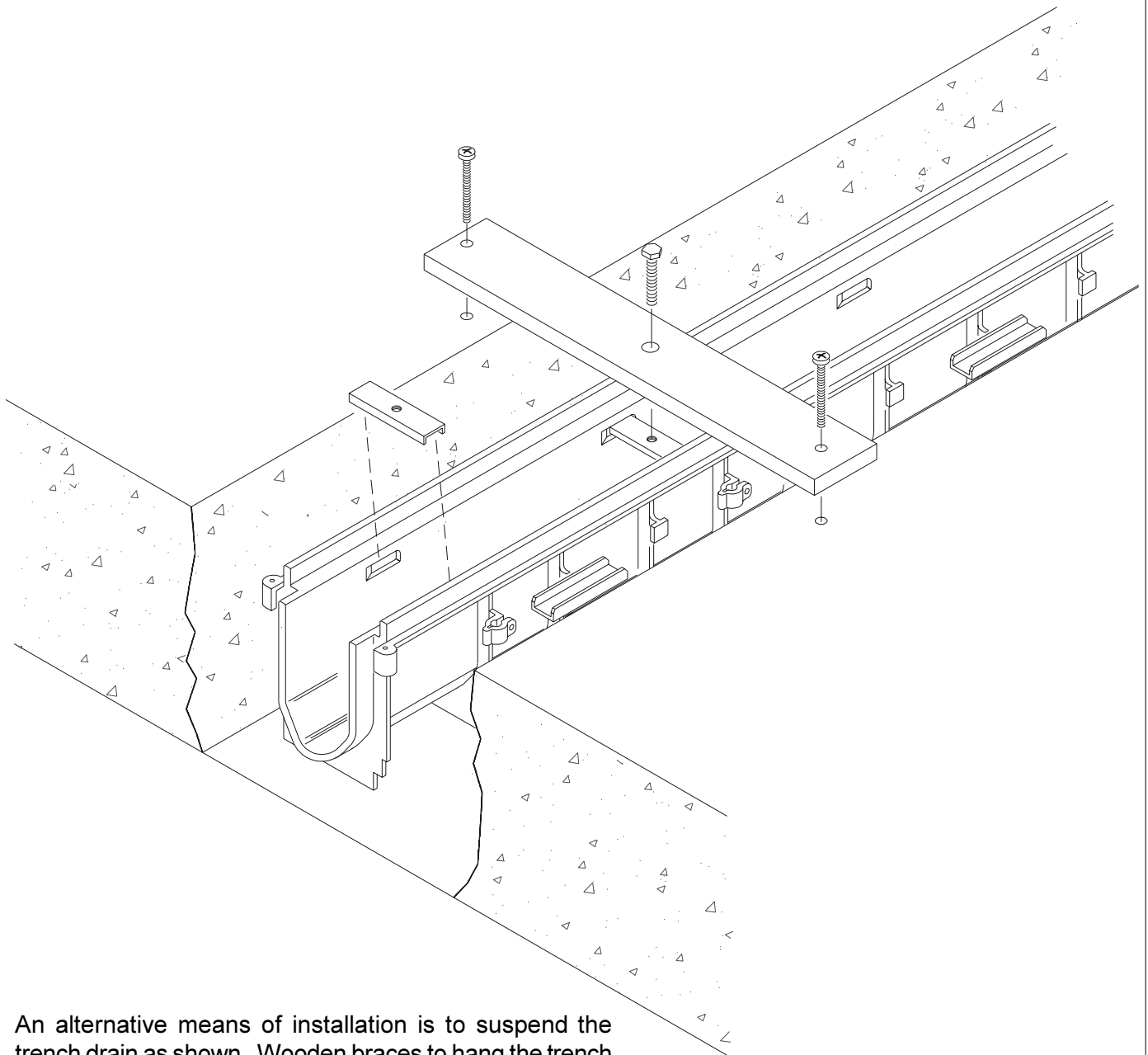

An alternative means of installation is to suspend the trench drain as shown. Wooden braces to hang the trench run can be attached to the drain body through the grate lock down bars as illustrated above.

Joint Connection

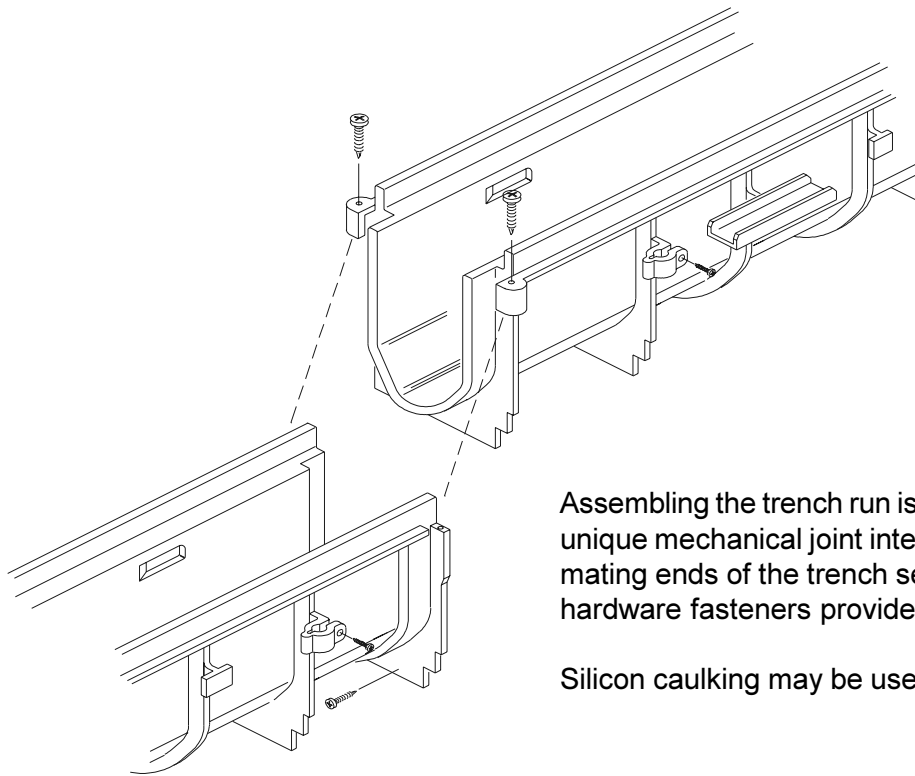

Assembling the trench run is easy with Perma-Trench's unique mechanical joint interlock. Simply align the two mating ends of the trench sections and fasten with the hardware fasteners provided.

Silicon caulking may be used at each joint as a sealer.

A joint connector (JC) is available to join two trench sections without the interlocking joint, such as sections that may be flowing in opposite directions. Cut the lengths and fasten the JC as shown. The connection can be sealed with a silicon caulking and held in place mechanically with the fasteners provided in the accessory assembly bag.

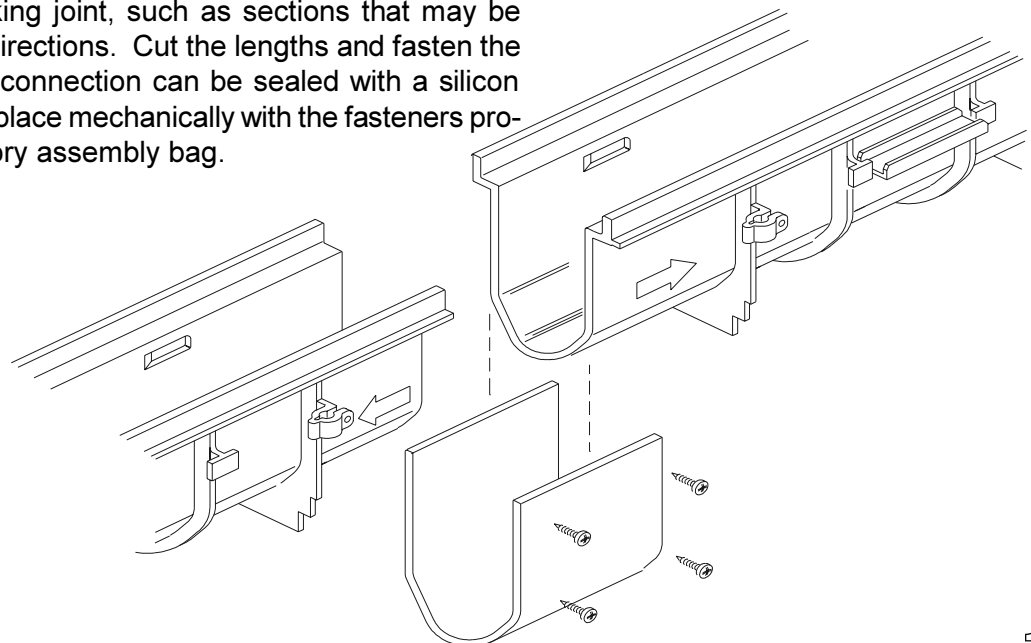

Spacer Bars

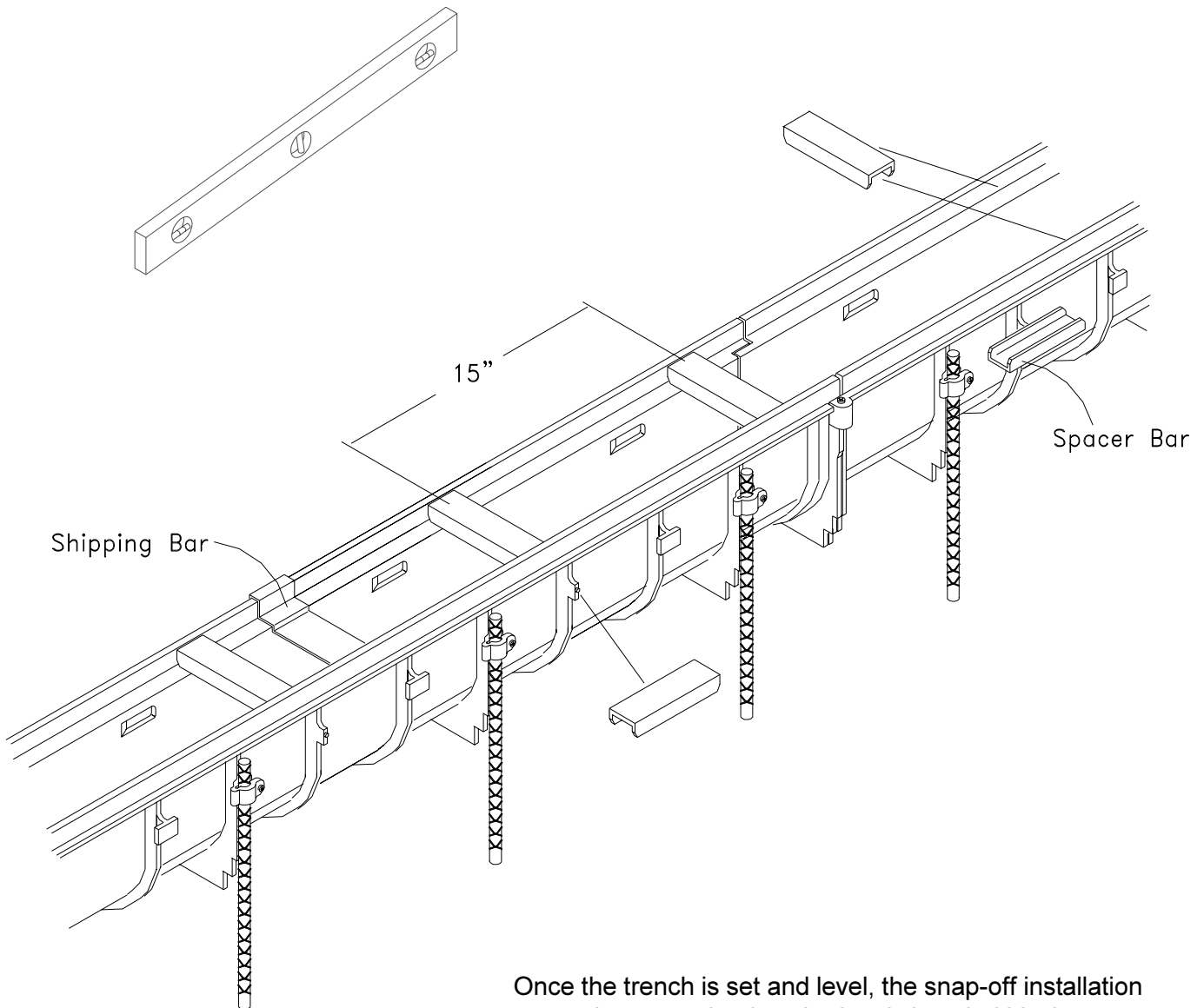

Once the trench is set and level, the snap-off installation spacer bars must be detached and placed within the grate ledge as shown. The spacer bars can be found along the outside edge of the trench between the integral rebar clips. To remove the bars simply twist and snap off.

Placement of these spacer bars should be about every 15 inches throughout the entire length of the trench run. These temporary spacer bars must remain in place until the concrete has set to ensure proper fit of the grating. Any shipping bars still left in the trench sections should be removed at this time.

Catch Basins

To make a catch basin connection, simply invert the catch basin and remove the basin end cap as shown.

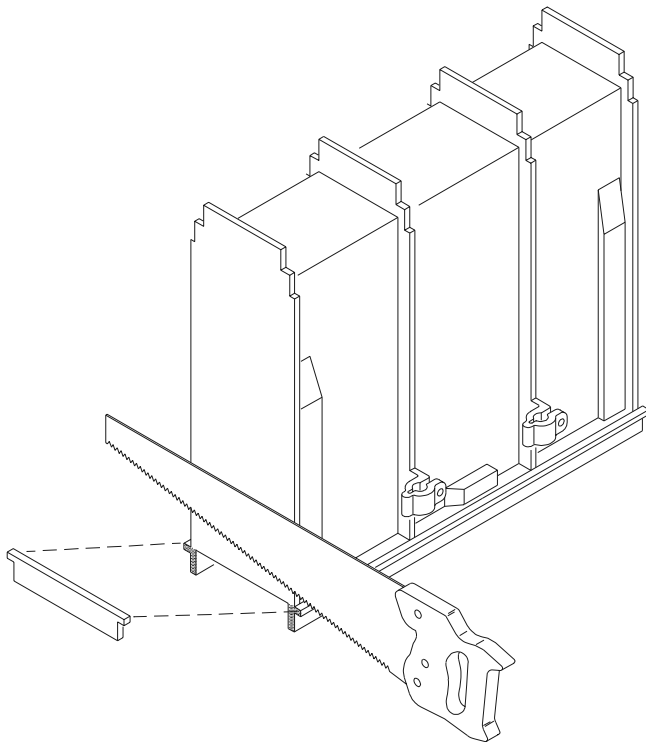
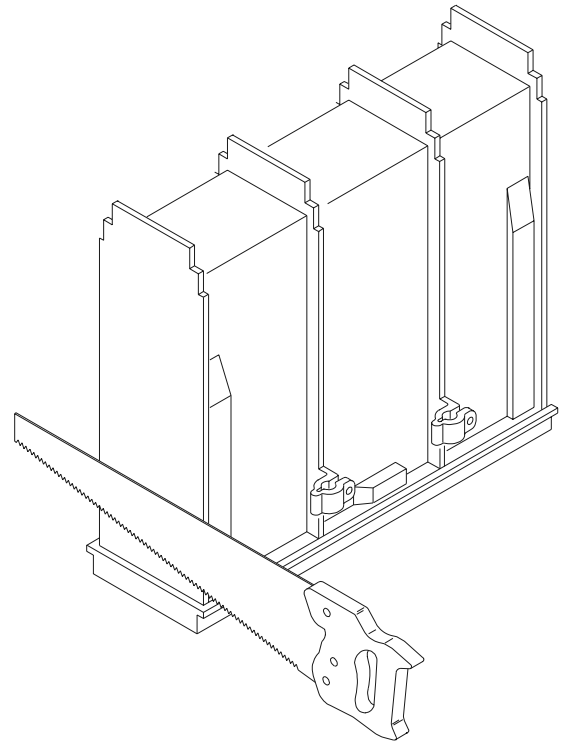

This can be easily accomplished with the use of a hand saw or power reciprocating saw. Use the bottom ledge of the end cap as a guide.

****BEFORE POURING THE CONCRETE, BE SURE THAT PROPER STYROFOAM OR WOOD BRACING IS PLACED INSIDE CATCH BASIN TO PREVENT DEFLECTION FROM THE CONCRETE ON SIDES.****

Basins

Cont'd

With the end cap removed from the catch basin, place the basin and the incoming trench section upside down on a flat surface as shown.

Align the MALE end of the trench section with the catch basin and trace the trench profile on the end of the basin.

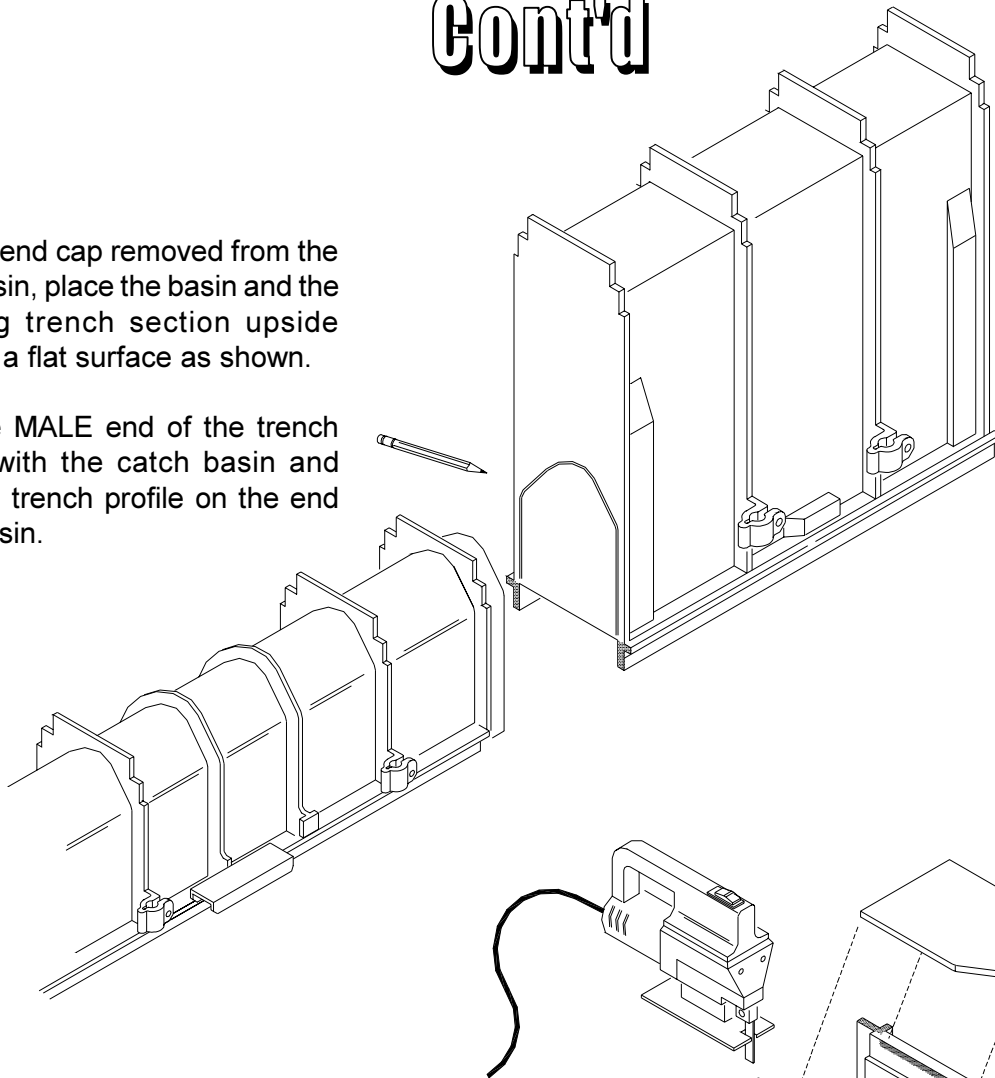

The cutout for the incoming trench can be made easily with an electric jigsaw as shown. A shorter blade about 1-inch is ideal for this cut.

Attach the incoming trench section with the hardware provided to complete the connection.

****BEFORE POURING THE CONCRETE, BE SURE THAT PROPER STYROFOAM OR WOOD BRACING IS PLACED INSIDE CATCH BASIN TO PREVENT DEFLECTION FROM THE CONCRETE ON SIDES.****

Pouring the concrete

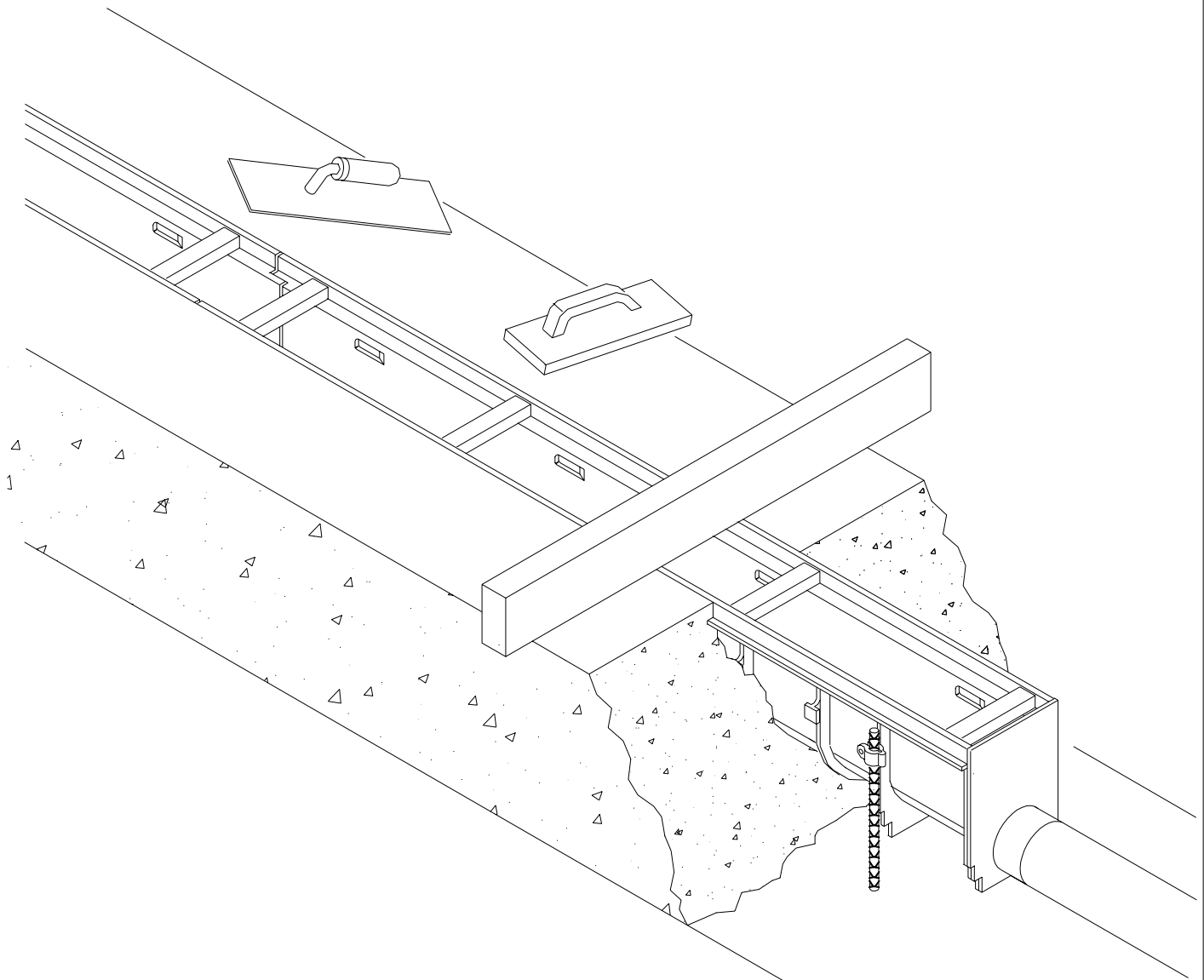

Pour the concrete around the three sides of the trench drain. Be certain to adequately **VIBRATE** the concrete as it is being placed. Proper vibration will eliminate any unwanted voids within the concrete pour.

Finish troweling should be done to set the top edge of the trench drain about 1/16" below the floor grade. Remember to compensate for concrete shrink that may occur during cure so that the edge of the trench drain does not protrude above the finished floor grade.

Flo-Thru Z-886 Check List

CHANNELS

- _____ #8601
- _____ #8602
- _____ #8603
- _____ #8603N
- _____ #8604
- _____ #8605
- _____ #8606
- _____ #8606N
- _____ #8607
- _____ #8608
- _____ #8609
- _____ #8610
- _____ #8611
- _____ #8612
- _____ #8612N
- _____ #8613
- _____ #8614
- _____ #8615

FRAME (optional)

- _____ (HD) Heavy-Duty Frame w/ Studs
- _____ (HDS) S.S. Heavy-Duty Frame w/ Studs
- _____ (HDG) Galv. Heavy-Duty Frame w/ Studs
- _____ (SVF) S.S. Veneer Frame

ENDCAPS/OUTLETS/ACCESSORIES

- _____ (E1) Closed End Cap
- _____ (E2) 2"NH End Cap
- _____ (E3) 3"NH End Cap
- _____ (E4) 4"NH End Cap
- _____ (E6) 6"NH End Cap
- _____ (U2) 2" Bottom Outlet
- _____ (U3) 3" Bottom Outlet
- _____ (U4) 4" Bottom Outlet
- _____ (U6) 6" Bottom Outlet
- _____ (DB) Bottom Dome Strainer
- _____ (JC) Joint Connector
- _____ (T) "T" Connection Adapter
- _____ (GL) Bag #840 Grate Lockdown
- _____ Bag #841 Channel Assembly Screws
- _____ Bag #844 Accessory Screws

GRATES

Cast Grates - 20"

- _____ (CC) Solid Cast Iron
- _____ (CG) Cast Iron
- _____ (DG) Ductile Iron
- _____ (GCG) Galvanized Cast Iron
- _____ (HP) [HPD] Ductile Heel Proof
- _____ (HPP) Heel Proof Polyethylene
- _____ (LC) Cast Iron Longitudinal
- _____ (LD) Ductile Longitudinal Slot

Fabricated Grates - 60"

- _____ (FG) Galv. Slotted
- _____ (RFG) Galv. Slotted (reinforced)
- _____ (GC) Galv. Cast Iron
- _____ (GD) Galv. Ductile
- _____ (GG) Fiberglass
- _____ (PG) Galv. Perf.
- _____ (RPG) Galv. Perf. (reinforced)
- _____ (ST) Galv. Solid Cast Iron

Stainless Grates - 60"

- _____ (FS) S.S. Slotted
- _____ (RFS) S.S. Slotted (reinforced)
- _____ (LS) S.S. Small Slot (H.D.)
- _____ (PS) S.S. Perf.
- _____ (RPS) S.S. Perf. (reinforced)
- _____ (SBG) S.S. Bar - 20"
- _____ (SBGHP) S.S. HP Bar - 20"

Z-887

Z-887-1

- _____ 6 X 20 Catch Basin
- _____ (SVF) S.S. Veneer Frame
- _____ (HD) Heavy Duty Frame w/ Studs

Z-887 Outlets

- _____ E3/U3 (Z-887) 3" Outlet
- _____ E4/U4 (Z-887) 4" Outlet

Buckets

- _____ Y6 6" Galv. or S.S. Sediment Bucket
- _____ Y12 12" Galv. or S.S. Sediment Bucket
- _____ Y24 24" Galv. or S.S. Sediment Bucket