

## Double Containment Trench Drain System Typical section drawing

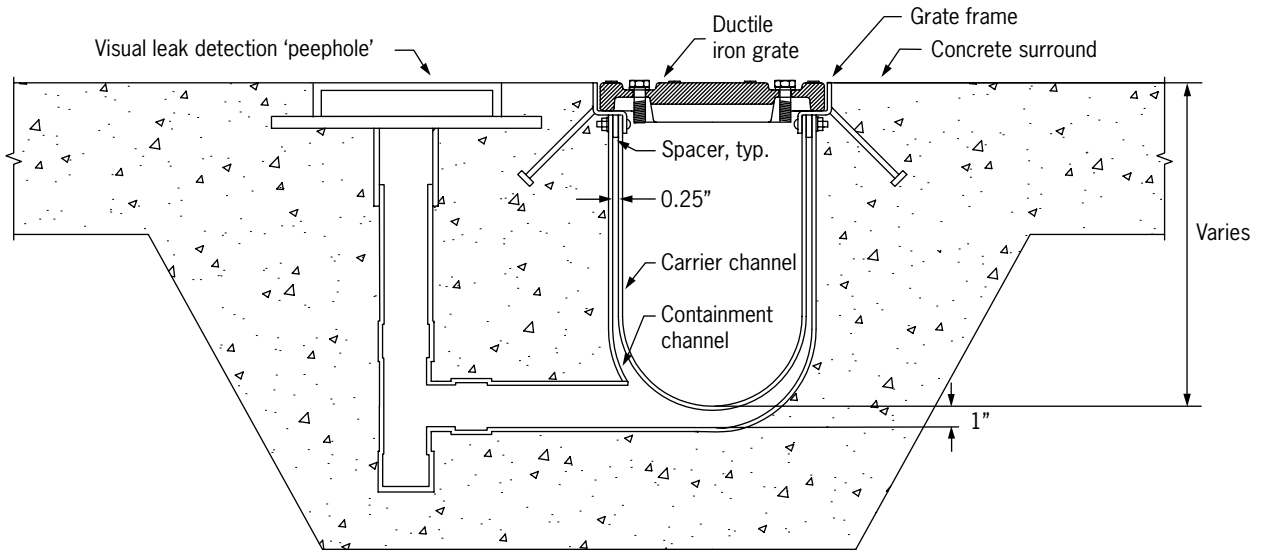

Typical Aquaduct Custom Double Containment Trench Drain System  
(NTS)

## Specification

### Part I - General

**1.1 General** - All materials and equipment necessary to install a custom double containment trench drainage system as specified and as shown on the working drawings shall be included.

**1.2 Related Work** - Work specified in other sections includes but is not limited to: Excavation and backfill, cast-in-place concrete, and mechanical equipment.

**1.3 System Description** - Custom double containment trench drain system.

**1.4 Submittals** - Manufacturer will submit, when required, shop drawings showing schematic plan of total drainage system listing all parts being provided with exact center-line dimensions suitable for installation. Copies of the manufacturer's recommended method of installation, assembly, and anchorage shall be submitted for review.

**1.5 Project History** - Manufacturer shall submit a list of projects installed during the past twenty years, if required.

**1.6 Warranty** - ACO provides a limited warranty of one year based on installation according to manufacturer's installation instruction data.

### Part II - Product

**2.1 Products** - Manufacturer shall be ACO Polymer Products, Inc., Chardon, Ohio.

#### 2.2 Physical & Mechanical Characteristics

a. **Channel body material:** [Fiberglass] [Stainless steel]

##### *If Fiberglass*

- (i) **Resin:** [Orthophthalic Polyester] [Isophthalic Polyester] [Standard Vinyl Ester] [Premium Vinyl Ester] [Other – please specify].
- (ii) **Reinforcements:** [Standard glass reinforcement] [Other – please specify].
- (iii) **Additives:** [Abrasion Resistant Gel Coat] [Special Fire-Retardant Resin] [Ultra-violet Light Inhibitor] [Other – please specify].
- (iv) **Edge Rail:** [Coated steel] [Galvanized steel] [Stainless steel] [Other – please specify].

##### *If Stainless Steel*

- (i) **Grade of Steel:** [Grade 304] [Grade 316] [Other – please specify].
- (ii) **Finish:** [Bead blasted] [pickle-passivated] [Electro-polished].
- b. **Chemical resistance required:** [None] [Yes – please specify chemicals present].
- c. **Channel Width:** [4"] [8"] [12"] [16"] [Other – please specify].
- d. **Channel Profile:** [Square base] [U/V shape] [Other – please specify].
- e. **Slope:** [Neutral] [1% sloped] [Other – please specify].
- f. **Grate Material:** [Galvanized steel] [Stainless steel] [Fiberglass] [Grey iron] [Ductile iron] [Other – please specify].
- g. **Grate Style:** [ADA compliant] [Slotted] [Bar]
- h. **Grate Locking System:** [No locking] [2-Bolts per grate] [4-Bolts per grate] [Other – please specify].
- i. **Grate Load Class:** [Specify Load Rating Required]
- j. **Outlets:** Vertical Outlet Schedule 40 pipe [4 inches] [6 inches] [8 inches] [10 inches] [Other – please specify].
- k. **Catch Basin:** [Please Specify size required]
- l. **Accessories:** [Please specify other special requirements]
- m. **Leak identification method:** [Visual port inspection] [Electronic sensor – by other manufacturer]

**2.5 Approved Supplier** – Aquaduct, (A Division of ACO Polymer Products, Inc.), 12080 Ravenna Road, PO Box 245, Chardon, OH 44024, Telephone (800) 662-2377, Fax (704) 568-4387

### Part III - Installation

**3.1 Site Preparation** - Excavate area for channel placement wide enough and deep enough to accommodate the channel and a minimum of 6 inch (150mm) concrete encasement. Channels require a minimum of 6 inches (150mm) of concrete support on both sides as well as beneath channel. The finished level of the concrete surround must be approx. 1/8" above the top of the channel edge.

**3.2 Installation** - Channel sections are installed starting from the outlet or catch basins. Insert channels from above to allow ends to interlock. Channel sections shall be attached to rebar or suspended to obtain correct finished elevation. An ACO approved installer shall seal joints and system shall be water tested for leaks before pouring concrete. Cover top of channels with tape, plastic, or plywood strips to protect channel surface during concrete pour. Place concrete in a manner that will not dislodge the channels.

**3.3 Finishing and Clean-up** - Following final set of concrete, remove protection covering the top of channels.

**3.4** Install in strict accordance with manufacturer's recommendations and drawings.

**ACO Polymer Products, Inc.**  
12080 Ravenna Road  
P.O. Box 245  
Chardon, OH 44024  
Tel: (800) 543-4764  
Fax: (440) 285-7005  
Email: info@acousa.com

**Aquaduct Support Office**  
Tel: (800) 662-2377  
Fax: (704) 568-4387  
Email: aquaduct@acousa.com