

# System 2000 - Safety Edge

## Slot channel trench drain system with cellular rubber safety edge

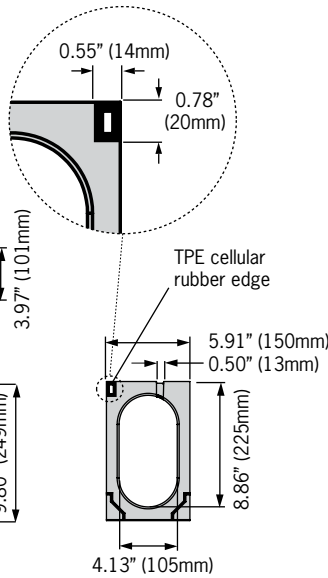

### One meter channel

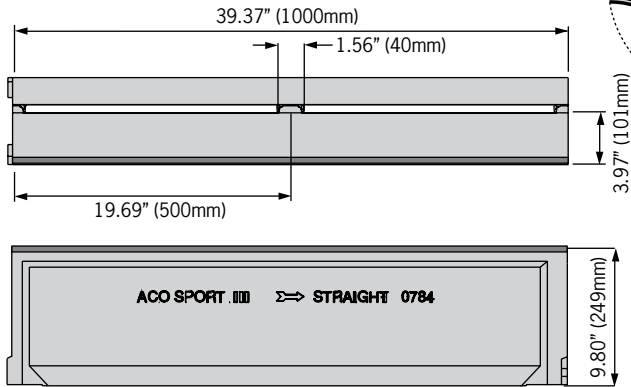

### Half meter channel

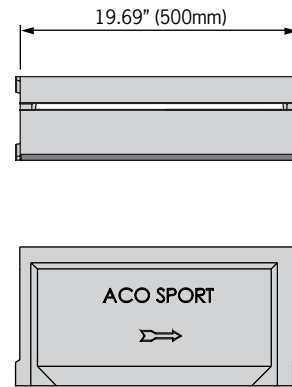

### In-line catch basin

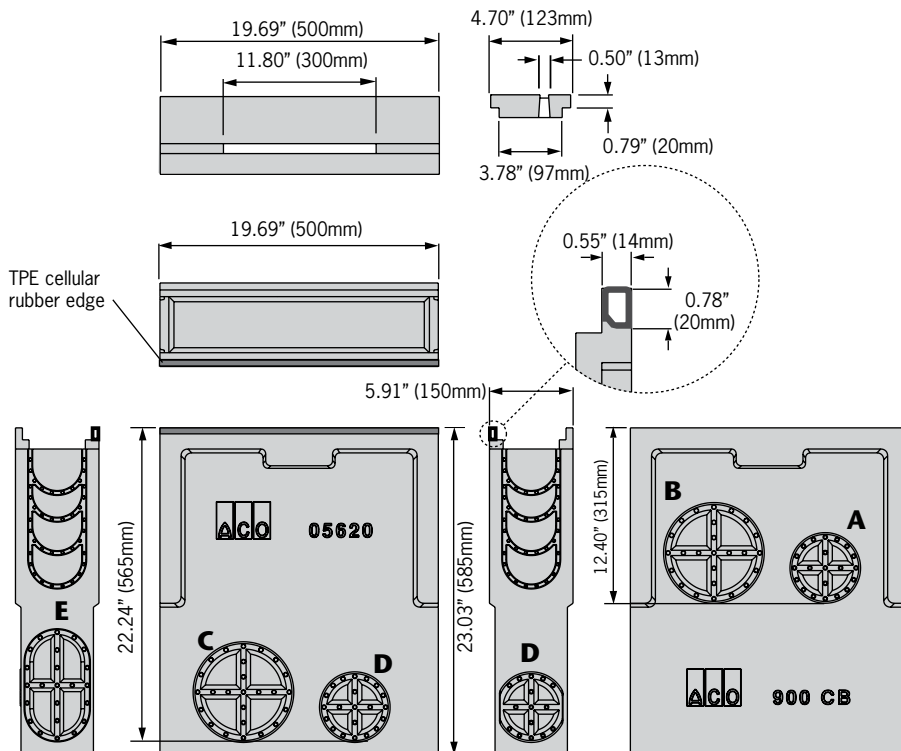

Holding capacity - 5.9 Gallons

### Outlet flow rates

Outlet	Product	Outlet size (Sch. 40)	Invert Depth	GPM	CFS
A	In-line catch basin*	4" round	12.40	175	0.40
B	In-line catch basin*	6" round	12.40	379	0.87
C	In-line catch basin*	6" round	22.24	530	1.22
D	In-line catch basin*	4" round	22.24	242	0.54
E	In-line catch basin*	6" oval	22.24	372	0.86

\* In-line catch basin flow rate without trash bucket - using trash bucket reduces flow

ACO Specification Information



# ACO SPORT

## System 2000 Slot Channel trench drain system with safety edge

Description	Part No	Invert Depth		Overall Depth		Wgt lbs
		inches	mm	inches	mm	
System 2000SE Straight channel - 39.37" (1000mm)	00789	8.86	225	9.84	250	66.0
System 2000SE Straight channel - 19.69" (500mm)	00790	8.86	225	9.84	250	33.0
<b>Catch basin</b>						
System 2000SE In-line catch basin - 19.69" (500mm)	06567	22.13	562	23.03	585	57.0
Polymer concrete catch basin cover - 19.69" (500mm)	00788	-	-	-	-	9.0
Series 900 plastic trash bucket	01498	-	-	-	-	1.1
6" oval to round adapter (to fit outlet E)	95140	-	-	-	-	1.1

**Notes:**

1. For maximum hydraulic efficiency remove trash bucket from in-line catch basin

<p><b>Part I - General</b></p> <p>1.1 <b>Related Work</b> - Work specified in other sections includes but is not limited to: Excavation and backfill, cast-in-place concrete, and mechanical equipment.</p> <p>1.2 <b>System Description</b> - Modular trench drainage system manufactured from corrosion resistant polyester polymer concrete including interconnecting modular components.</p> <p>1.3 <b>Submittals</b> - Manufacturer will submit, when required, shop drawings showing schematic plan of total drainage system listing all parts being provided with exact center-line dimensions suitable for installation. Copies of the manufacturer's recommended method of installation shall be submitted for review.</p> <p>1.4 <b>Project History</b> - Manufacturer shall submit a list of installed projects, if required.</p> <p>1.5 <b>Warranty</b> - ACO provides a limited product warranty of one year based on installation according to manufacturer's installation instruction data.</p>	<p><b>Part II - Product</b></p> <p>2.1 <b>Products</b> - Manufacturer shall be ACO, Inc.</p> <p>2.2 <b>Physical &amp; Mechanical Characteristics</b></p> <ul style="list-style-type: none"> <li>• Overall width - 5.91 inches (150mm)</li> <li>• Internal width - 4.13 inches (105mm)</li> <li>• Unit depth - 9.84 inches (250mm)</li> <li>• Unit length - 39.37 inches (1000mm), or 19.69" (500mm)</li> <li>• Compressive strength - 14,000 psi</li> <li>• Flexural strength - 4,000 psi</li> <li>• Water absorption rate - &lt;0.1% by weight.</li> <li>• 0.5" (13mm) inlet slot - ADA compliant to American Disabilities Act of 1990 Section 4.5.4</li> <li>• TPE cellular rubber safety edge</li> </ul> <p>2.3 <b>Channel Profile</b> - Each unit will feature a full radius in the trench bottom and male to female interconnecting ends. Units shall have horizontal cast-in anchoring features on outside walls to ensure maximum mechanical bond to surrounding bedding material. Each unit shall have a 0.5" (12.7mm) longitudinal inlet slot on the top surface.</p> <p>2.4 <b>Radius Channels</b> - Shall be manufactured to enable a radius of 36.5 meters, per IAAF guidelines.</p> <p>2.5 <b>Catch Basins</b> - Shall be manufactured from polymer concrete, be one half meter (19.69") in length and include a trash bucket (optional) and removable polymer concrete cover.</p> <p><b>Part III - Installation</b></p>	<p>3.1 <b>Site Preparation</b> - Excavate an area wide enough and deep enough to accommodate the ACO SPORT System 2000 channel, allowing a minimum of 4 inches (100mm) concrete encasement (recommended 4,000psi) on 3 sides to provide support on both sides as well as beneath channel. Top of channel must be evenly aligned to the surface of the surrounding slab. See installation section for haunch details for different loadings &amp; pavement materials.</p> <p>3.2 <b>Installation</b> - Channel sections are installed from the outlet or catch basins. Insert channels from above to allow ends to interconnect. Channel sections shall be placed on brick, rebar basket, low slump concrete slurry, or with installation devices, to obtain correct finished elevation. Cutting will be made, if required, by masonry or concrete saw. Use tape or plastic to protect top surface of channel from concrete splash during concrete pour. Place concrete in a manner that will not dislodge the channels.</p> <p>3.3 <b>Finishing and Clean-up</b> - Following final set of concrete, remove protection covering the top of channel and thoroughly flush system to remove debris.</p> <p>3.4 Install in strict accordance with manufacturer's recommendations and drawings. Details available at <a href="http://www.ACOSport.us">www.ACOSport.us</a>.</p>
--	---	--

**ACO, Inc.**

**West Sales Office**

825 W Beechcraft Street  
 Casa Grande, AZ 85122  
 Tel: (520) 421-9988  
 Toll Free: (888) 490-9552  
 Fax: (520) 421-9899

**Northeast Sales Office**

9470 Pinecone Drive  
 Mentor, OH 44060  
 Tel: (440) 639-7230  
 Toll free: (800) 543-4764  
 Fax: (440) 639-7235

**Southeast Sales Office**

4211 Pleasant Road  
 Fort Mill, SC 29708  
 Toll free: (800) 543-4764  
 Fax: (803) 802-1063

**Follow us on**



**Electronic Contact:**

info@ACOSport.us  
[www.ACOSport.us](http://www.ACOSport.us)



© April 2018, ACO, Inc. This information is believed to be accurate but it is not guaranteed to be so. We cannot assume liability for results that buyer obtains with our product since conditions of use are beyond the control of the company. It is the customer's responsibility to evaluate suitability and safety of product for his own use. ACO, Inc. reserves the right to change the product and specifications without notice. Re-order AS038