

FlowDrain - FG200 Ductile Iron Slotted Grate

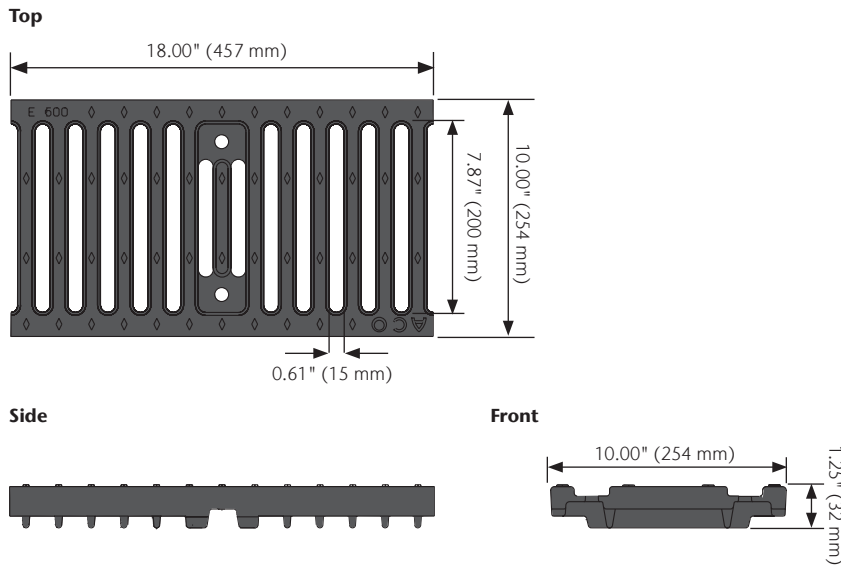
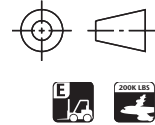

Specifications

General

The surface drainage system shall be ACO Drain FG200 channels complete with ACO FG200 ductile iron slotted grate with bolt-locking as manufactured by ACO, Inc. or similar approved.

Materials

The covers shall be manufactured from ductile iron and have minimum properties as follows:

- Independently certified to meet Load Class E to EN 1433 - 134,885 lbs - 2,321 psi.
- Ductile iron to ASTM 536 - Grade 80-55-06.
- Intake area of 58.7 in² (378.7 cm²) per 18" of grate.

The overall width of 10.00" (254 mm) and overall length of 18.00" (457 mm). Slots measure 7.87" (200 mm) by 0.61" (15 mm).

Grates

Grate is slotted ductile iron. Ductile iron ASTM 536 - Grade 80-55-06. After removal of the grates there shall be uninterrupted access to the trench to aid maintenance.

Installation

The trench drain system and grates shall be installed in accordance with the manufacturer's installation instructions and recommendations.

Product Features

- Certified to EN 1433 Load Class E - 134,885 lbs - 2,321 psi
- Bolted locking system
- Suitable for use with FG200 channels
- Manufactured from ductile iron to ASTM A 536 - Grade 80-55-06
- E-coated for improved resistance against corrosion

Parts

	Part No.	Length in (mm)	Width in (mm)	Weight lbs
FG200 Ductile Iron Slotted Grate	93896	18.00 (457)	10.00 (254)	28.7
Replacement Stainless Steel Hex Head Bolts (Qty 2)	93892	-	-	0.2



EN 1433 Load Class E
134,885 lbs - 2,321 psi
200,000 lb Proof Load

ACO, Inc.

West Sales Office
825 W. Beechcraft Street
Casa Grande, AZ 85122
Tel: (520) 421-9988
Toll-Free: (888) 490-9552
Fax: (520) 421-9899

Northeast Sales Office
9470 Pinecone Drive
Mentor, OH 44060
Tel: (440) 639-7230
Toll-Free: (800) 543-4764
Fax: (440) 639-7235

Southeast Sales Office
4211 Pleasant Road
Fort Mill, SC 29708
Toll-Free: (800) 543-4764
Fax: (803) 802-1063

info@acousa.com
www.acousa.com

© February 2021 ACO, Inc.

All reasonable care has been taken in compiling the information in this document. All recommendations and suggestions on the use of ACO products are made without guarantee since the conditions of use are beyond the control of the company. It is the customer's responsibility to ensure that each product is fit for its intended purpose and that the actual conditions of use are suitable. ACO, Inc. reserves the right to change products and specifications without notice.

ACO. creating
the future of drainage



ACO Specification Information