

K1-621S Catch Basin

K1-621S Catch Basin

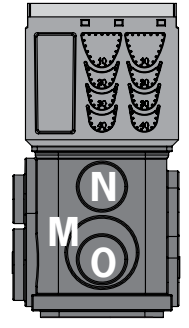
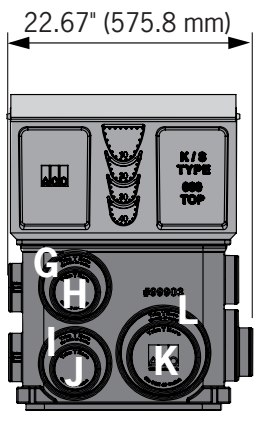
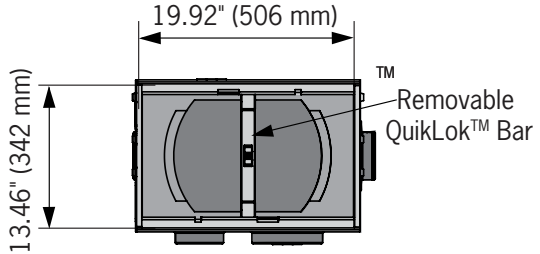
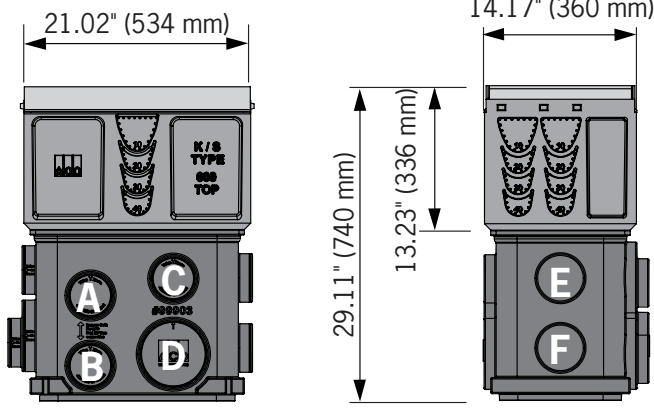
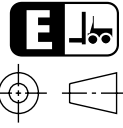

Outlet flow rates

Outlet	Product	Outlet size (Sch. 40)	Invert Depth	GPM	CFS
A	Type K1-621S	4" round	21.29"	239	0.53
B	Type K1-621S	4" round	27.79"	276	0.62
C	Type K1-621S	4" round	19.72"	229	0.51
D	Type K1-621S	6" round	27.79"	610	1.36
E	Type K1-621S	4" round	19.84"	230	0.51
F	Type K1-621S	4" round	26.34"	269	0.60
G	Type K1-621S	6" round	20.62"	514	1.15
H	Type K1-621S	4" round	20.07"	231	0.52
I	Type K1-621S	6" round	27.76"	609	1.36
J	Type K1-621S	4" round	27.19"	273	0.61
K	Type K1-621S	6" round	27.19"	602	1.34
L	Type K1-621S	8" round	27.76"	1061	2.36
M	Type K1-621S	6" round	26.28"	591	1.32
N	Type K1-621S	4" round	19.15"	225	0.50
O	Type K1-621S	4" round	25.86"	266	0.59

Notes:
 1. These are the pipe flow rates at the specified outlet, **NOT** channel flow rates.
 *Flow rates without trash bucket - using trash bucket or filter bag reduces flow rates.
 2. 4" diameter foul air trap, part# 90854, can be fitted to catch basin base at outlet positions A/B and E/F

Trash Bucket

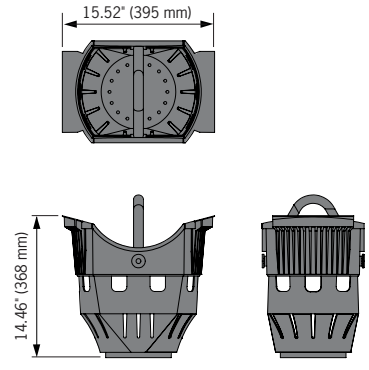

Note: Openings in trash bucket are 35.7"² (23,033mm²)

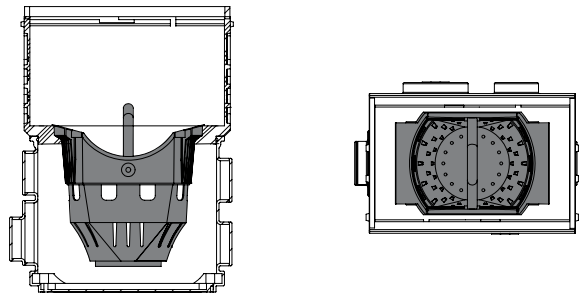

Note: Trash bucket position within K1-621S catch basin body and base

ACO Specification Information



ACO DRAIN

K1-621S Catch Basin



ACO Specification Information

Description	Part No.	Invert Depth inches	mm	Weight lbs.
Type K1-621S Catch basin assembly - top, removable QuickLok™ bar, trash bucket & base	94618	28.86	733.2	55.8
Catch Basin Components				
Type 600 optional riser	99902	40.86	1038	10.0
Foul air trap - fits both Type 900 & Type 600 basins	90854	-	-	1.2
QuickLok™ grate removal tool	01318	-	-	0.3

Optional riser detail (Part# 99902)

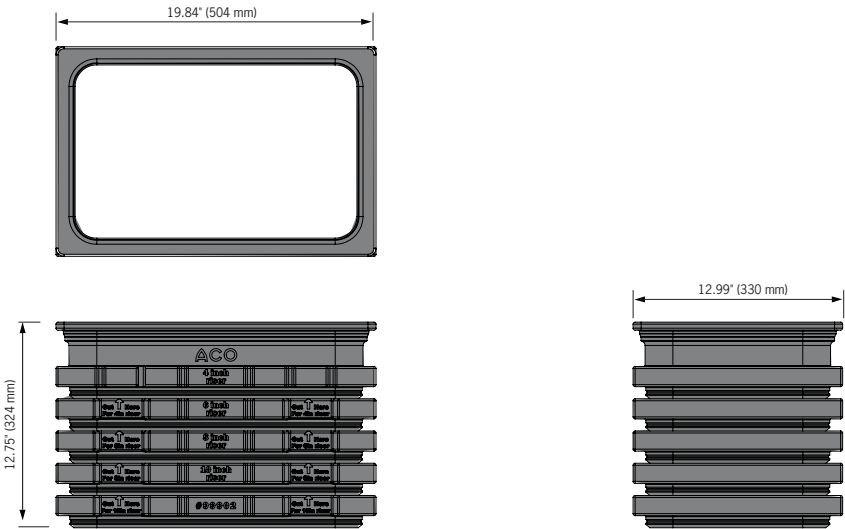

- Notes:**
- Riser can be cut down in 1" (25mm) increments.
 - Addition of riser will alter the outflow rates of base as shown on table overleaf.

Specifications			Optional Riser
General The catch basin shall be ACO Drain K1-621S Catch Basin - comprising of top section, trash bucket and base as manufactured by ACO, Inc. or similar approved.	Salt proof	YES	Optional riser can be useful between polymer concrete top unit and LLDPE base unit. Use of riser is determined by access and local building codes.
	Dilute acid and alkali resistant	YES	
Materials The top unit body shall be manufactured from polyester polymer concrete with minimum properties as follows:	The nominal clear opening shall be 13.46" (342mm) wide by 19.92" (506mm) long. Overall width of 22.70" (575.8mm) by 15.38" (390.6mm) long. Type K1-621S catch basin assembly has overall depth of 29.11" (739.5mm). Polymer concrete top units shall incorporate a cast in stainless steel frame manufactured with drillouts for channel connection and have a wall thickness of at least 0.59" (15mm). Top units shall have horizontal cast in anchoring key features on the outside to ensure maximum mechanical bond to the surrounding bedding material and pavement surface. The base unit shall be a LLDPE plastic molding and incorporate molded plastic pipe stubbs to facilitate pipe connection.		Grates Grates shall be specified. See separate ACO Spec Info grate sheets for details. After removal of grates and QuickLok™ bar there shall be uninterrupted access to the basin to aid maintenance. Accepts all half-meter ACO K300 Drainlok grates or K300 QuickLok™ grates with optional QuickLok™ bar.
Compressive strength:	14,000 psi		Installation The trench drain system shall be installed in accordance with the manufacturer's installation instructions and recommendations.
Flexural strength:	4,000 psi		
Water absorption	0.07%		
Frost proof	YES		

ACO, Inc.
Northeast Sales Office
 9470 Pinecone Drive
 Mentor, OH 44060
 Tel: (440) 639-7230
 Toll free: (800) 543-4764
 Fax: (440) 639-7235

West Sales Office
 825 W. Beechcraft St.
 Casa Grande, AZ 85122
 Tel: (520) 421-9988
 Toll Free: (888) 490-9552
 Fax: (520) 421-9899

Southeast Sales Office
 4211 Pleasant Road
 Fort Mill, SC 29708
 Toll free: (800) 543-4764
 Fax: (803) 802-1063

Electronic Contact:
 info@acousa.com
 www.acousa.com



© December 2018, ACO, Inc. This information is believed to be accurate but it is not guaranteed to be so. We cannot assume liability for results that buyer obtains with our product since conditions of use are beyond the control of the company. It is the customer's responsibility to evaluate suitability and safety of product for his own use. ACO, Inc. reserves the right to change the product and specifications without notice.