

# PowerDrain - S300K Ductile Iron Slotted Grate

Top

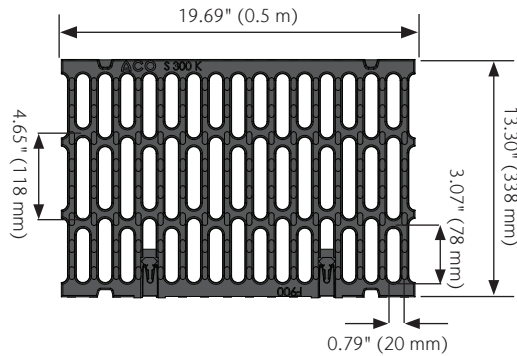

Side



Front

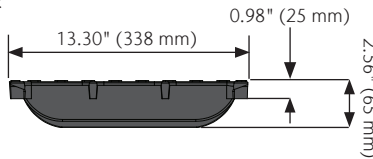

**PowerLok® Locking Mechanism**

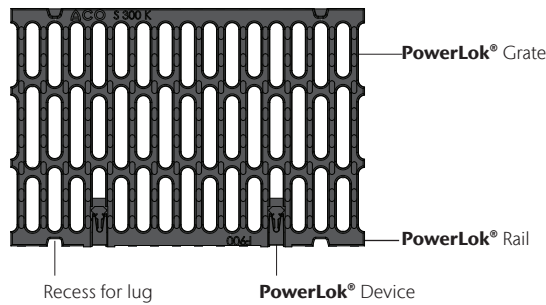

ACO PowerLok® is a patented boltless locking system. Grates are removed and replaced with minimum time and effort for ease of maintenance. Lugs on the rail opposite the PowerLok® device slots into recesses in the grate. The PowerLok device is used to engage the lug on the rail at two locations per grate to lock the grate to the channel.

**Product Features**

- Certified to EN 1433 Load Class F - 202,328 lbs - 3,481 psi
- Uses PowerLok® boltless locking system
- Suitable for use with S300K and H300SK-13 channels
- Manufactured from ductile iron to ASTM 536 - Grade 80-55-06
- E-coated for improved resistance against corrosion
- Recesses for anti-shunt lugs

**Parts**

	Part No.	Length in (mm)	Width in (mm)	Weight lbs
S300K Ductile Iron Slotted Grate	<b>02445</b>	19.69" (500)	13.19" (335)	55.0

**ACO, Inc.**

West Sales Office  
825 W. Beechcraft Street  
Casa Grande, AZ 85122  
Tel: (520) 421-9988  
Toll-Free: (888) 490-9552  
Fax: (520) 421-9899

Northeast Sales Office  
9470 Pinecone Drive  
Mentor, OH 44060  
Tel: (440) 639-7230  
Toll-Free: (800) 543-4764  
Fax: (440) 639-7235

Southeast Sales Office  
4211 Pleasant Road  
Fort Mill, SC 29708  
Toll-Free: (800) 543-4764  
Fax: (803) 802-1063

info@acousa.com  
www.acousa.com

© February 2021 ACO, Inc.

All reasonable care has been taken in compiling the information in this document. All recommendations and suggestions on the use of ACO products are made without guarantee since the conditions of use are beyond the control of the company. It is the customer's responsibility to ensure that each product is fit for its intended purpose and that the actual conditions of use are suitable. ACO, Inc. reserves the right to change products and specifications without notice.

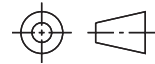

**Specifications**

**General**

The surface drainage system shall be ACO PowerDrain S300K or SlabDrain H300SK-13, complete with ACO S300K Ductile Iron Slotted Grate with PowerLok® locking as manufactured by ACO, Inc. or similar approved.

**Materials**

The covers shall be manufactured from ductile iron and have minimum properties as follows:

- Independently certified to meet Load Class F to EN 1433 - 202,328 lbs - 3,481 psi.
- Ductile iron to ASTM 536 - Grade 80-55-06.
- Intake area of 126.02 in<sup>2</sup> (813 cm<sup>2</sup>) per ½ meter of grate.

The overall width of 13.30" (338 mm) and overall length of 19.69" (500 mm). Slots measure at a maximum of 4.65" (118 mm) by 0.79" (20 mm).

**Grates**

Grate is slotted ductile iron. Ductile iron ASTM 536 - Grade 80-55-06. After removal of the grates there shall be uninterrupted access to the trench to aid maintenance. Grates can be used for PowerDrain or SlabDrain.

**Installation**

The trench drain system and grates shall be installed in accordance with the manufacturer's installation instructions and recommendations.



Bicycle-Safe



Anti-Slip Grate



EN 1433 Load Class F  
202,328 lbs - 3,481 psi



200,000 lb Proof Load

ACO Specification Information

