

**Product Features**

- Certified to EN 1433 Load Class E - 135,000 lbs - 2,788 psi
- Uses 'QuickLok' boltless locking system
- Suitable for use with K300, KS300, H300K-13, and H300KS-13 channels and 621G, 621S, 631G, 631S catch basins
- Manufactured from ductile iron to ASTM A 536-84 - Grade 65-45-12
- E- coated for improved resistance against rust
- Bicycle Tire Penetration Resistant to AS 3996 - 2006



ACO Specification Information

**Specifications**

**General**

The surface drainage system shall be ACO Drain K300, KS300, H300K-13, and H300KS-13, channels\* and 621G, 621S, 631G, and 631S catch basins complete with ACO Type 861Q Ductile iron slotted grate with 'QuickLok' locking as manufactured by ACO Polymer Products, Inc. or similar approved.

**Materials**

The covers shall be manufactured from ductile iron and have **minimum** properties as follows:

- **Independently certified to meet Load Class E to EN 1433 - 135,000 lbs - 2,788 psi**
- **Ductile iron to ASTM A 536-84 - Grade 65-45-12**
- **Intake area of 128.71 sq. in. (803.39 cm<sup>2</sup>) per half meter of grate**

The overall width of 13.31" (338mm) and overall length of 19.69" (500mm). Slots measure at a maximum of 5.71" (145mm).

**Installation**

The trench drain system and grates shall be installed in accordance with the manufacturer's installation instructions and recommendations.

\* delete as appropriate

# ACO DRAIN

## Type 861Q Ductile iron slotted grate



ACO Specification Information

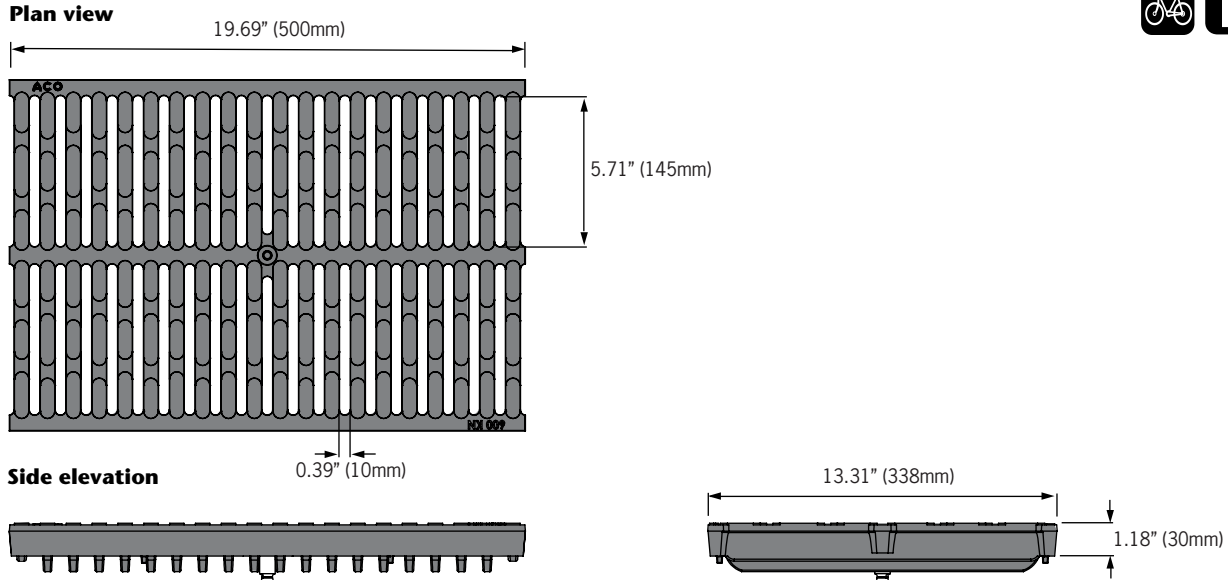

Description	Part No.	Length inches (mm)	Width inches (mm)	Weight lbs.
QuickLok grate				
Type 861Q Ductile iron slotted grate	<b>10431</b>	19.69 (500)	13.35 (339)	48.0
QuickLok locking bar	<b>10458</b>	-	-	0.5
QuickLok grate removal tool	<b>01318</b>	-	-	0.3

### 'QuickLok' locking mechanism

ACO 'QuickLok' is a patented boltless locking system, grates are removed and replaced with the minimum time and effort for ease of maintenance. The unique design provides a positive 'snap down' fit into the locking bar. A stud is fixed to the grate which 'locks' into the spring clip in the locking bar.

The 'QuickLok' stud is made from stainless steel and high density nylon, the locking bar and clip are stainless steel, for use in both general purpose and corrosive environments.

**ACO Polymer Products, Inc.**  
**Northeast Sales Office**  
 9470 Pinecone Drive  
 Mentor, Ohio 44060  
 Tel: (440) 639-7230  
 Toll free: (800) 543-4764  
 Fax: (440) 639-7235

**West Sales Office**  
 P.O. Box 12067  
 Casa Grande, AZ 85130  
 Tel: (520) 421-9988  
 Toll Free: (888) 490-9552  
 Fax: (520) 421-9899

**Southeast Sales Office**  
 4211 Pleasant Road  
 Fort Mill, SC 29708  
 Toll free: (800) 543-4764  
 Fax: (803) 802-1063

Follow us on  
  
**Electronic Contact:**  
 info@ACODrain.us  
 www.ACODrain.us



© August 2015 ACO Polymer Products, Inc. This information is believed to be accurate but it is not guaranteed to be so. We cannot assume liability for results that buyer obtains with our product since conditions of use are beyond the control of the company. It is the customer's responsibility to evaluate suitability and safety of product for his own use. ACO Polymer Products Inc. reserves the right to change the product and specifications without notice.