

**Type 878Q Longitudinal ductile iron grate (ADA)**

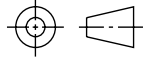

**Product Features**

- Certified to EN 1433 Load Class C - 56,000 lbs - 1,162 psi
- Uses 'QuickLok' boltless locking system
- Suitable for use with K300, KS300, H300K-13, and H300KS-13 channels and 621G, 621S, 631G, 631S catch basins
- Manufactured from ductile iron to ASTM A 536-84 - Grade 65-45-12
- E- coated for improved resistance against rust
- Complies with ADA - American Disabilities Act of 1990 Section 4.5.4
- Complies with ASME: A112.6.3 - 2001: Section 7.12  
Heel Resistant Strainers and Grates
- Bicycle Tire Penetration Resistant to AS 3996 - 2006



**Specifications**

**General**

The surface drainage system shall be ACO Drain K300, KS300, H300K-13, and H300KS-13, channels\* and 621G, 621S, 631G, and 631S catch basins complete with ACO Type 878Q longitudinal ductile iron grate with 'QuickLok' locking as manufactured by ACO Polymer Products, Inc. or similar approved.

**Materials**

The covers shall be manufactured from ductile iron and have **minimum** properties as follows:

- **Independently certified to meet Load Class C to EN 1433 - 56,000 lbs - 1,162 psi**
- **Ductile iron to ASTM A 536-84 - Grade 65-45-12**
- **Intake area of 61.85 sq. in. (665.16 cm<sup>2</sup>) per half meter of grate**

The overall width of 1.0" (338mm) and overall length of 0.31" (500mm). Slots measure at a maximum of 1.0" (25.5mm) by 0.31" (8mm).

**Installation**

The trench drain system and grates shall be installed in accordance with the manufacturer's installation instructions and recommendations.

\* delete as appropriate

ACO Specification Information

# ACO DRAIN

## Type 878Q Longitudinal ductile iron grate (ADA)

Plan view

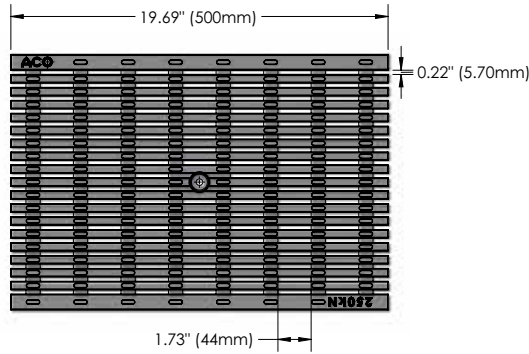

Side elevation



ACO Specification Information

Description	Part No.	Length inches (mm)	Width inches (mm)	Weight lbs.
<b>QuickLok grate</b>				
Type 878Q Ductile iron longitudinal grate	<b>138130</b>	19.69 (500)	13.31 (338)	52.91
QuickLok locking bar	<b>10458</b>	-	-	0.5
QuickLok grate removal tool	<b>01318</b>	-	-	0.3

### 'QuickLok' locking mechanism

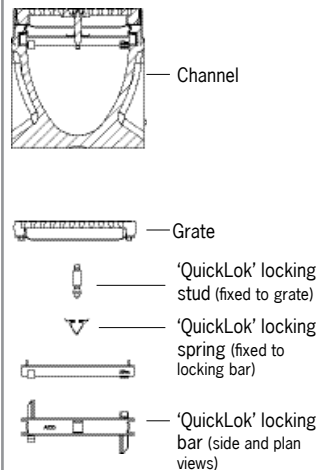

ACO 'QuickLok' is a patented boltless locking system, grates are removed and replaced with the minimum time and effort for ease of maintenance. The unique design provides a positive 'snap down' fit into the locking bar. A stud is fixed to the grate which 'locks' into the spring clip in the locking bar.

The 'QuickLok' stud is made from stainless steel and high density nylon, the locking bar and clip are stainless steel, for use in both general purpose and corrosive environments.

#### ACO Polymer Products, Inc.

##### Northeast Sales Office

9470 Pinecone Drive  
Mentor, OH 44060  
Tel: (440) 639-7230  
Toll free: (800) 543-4764  
Fax: (440) 639-7235

##### West Sales Office

825 W. Beechcraft St.  
Casa Grande, AZ 85122  
Tel: (520) 421-9988  
Toll Free: (888) 490-9552  
Fax: (520) 421-9899

##### Southeast Sales Office

4211 Pleasant Road  
Fort Mill, SC 29708  
Toll free: (800) 543-4764  
Fax: (803) 802-1063

#### Follow us on



#### Electronic Contact:

info@ACODrain.us  
www.ACODrain.us



© August 2016 ACO Polymer Products, Inc. This information is believed to be accurate but it is not guaranteed to be so. We cannot assume liability for results that buyer obtains with our product since conditions of use are beyond the control of the company. It is the customer's responsibility to evaluate suitability and safety of product for his own use. ACO Polymer Products Inc. reserves the right to change the product and specifications without notice.