

CAST IRON 24X24 TILE TOP VIEW

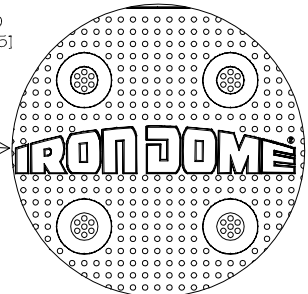

RAISED IRON DOME LOGO

1/4" 55 EXTRA WIDE TRUSS HEAD PHILLIPS SCREW X 1 1/2" LONG INTO 1/4" X 1 1/2" INSERT SEE DETAIL 2 (TYP. 6 LOC.) SEE DETAIL 3 FOR HOLE DIMENSIONS

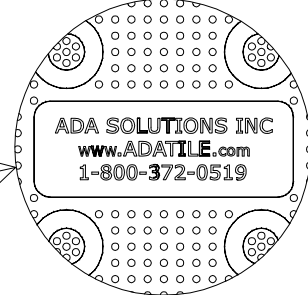

RAISED ADA INFO

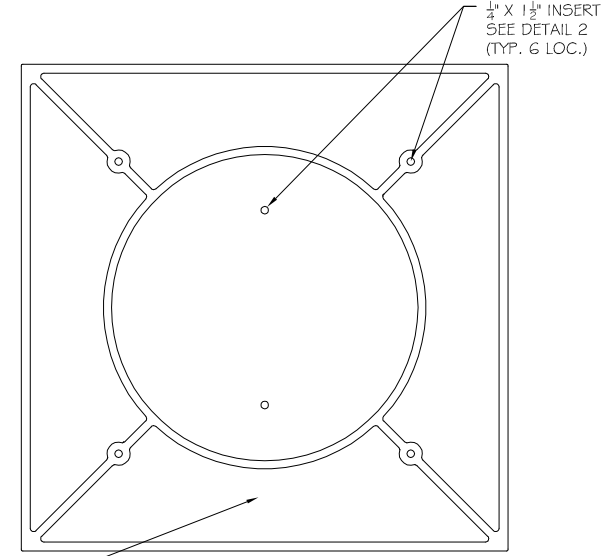

CAST IRON 24X24 TILE BOTTOM VIEW

RECESSED FOUNDRY LOGO, CAVITY NUMBER AND CAST DATE

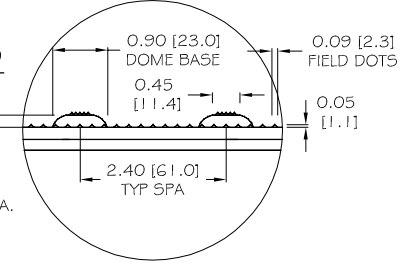

DETAIL 1

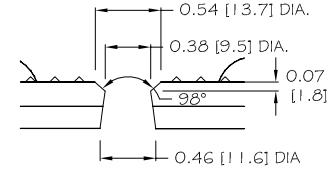

INSERT HOLE DETAIL

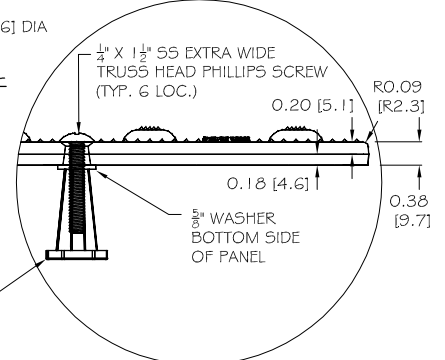

DETAIL 2

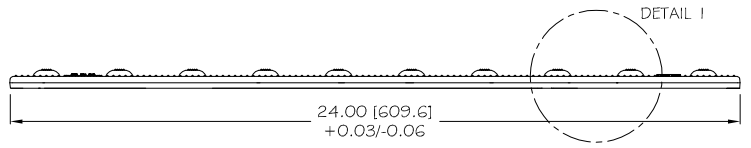

SECTION A

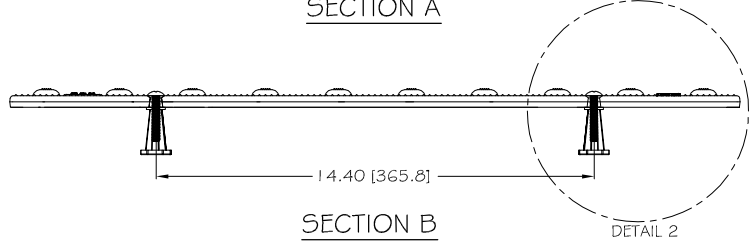

SECTION B

NOTE: PRIMARY DIMENSION INCHES mm IN PARENTHESES
ALL DIMENSIONS NOMINAL

TRADE TACTILE WARNING SURFACE	PART NO. 24X24 IRON DOME
MATERIAL CAST IRON	

PROJECT
IRON DOME[®]
 REPLACEABLE TACTILE WARNING SURFACE UNIT
 6-BOLT LOCATIONS
 PART SIZE 24" (610mm) X 24" (610mm)
 PLANS AND DETAILS

DRAWING NO. ADA-REP_CI2424_TH	REV 0	DATE 10-25-17
----------------------------------	----------	------------------



WWW.ADATILE.COM
 PHONE: (800)372-0519
 EMAIL: INFO@ADATILE.COM

- NOTES:
 1) CASTING TOLERANCES: +/- 0.03" UNLESS OTHERWISE SPECIFIED
 1/8" MAXIMUM WARP FROM CORNER TO CORNER
 2) MATERIAL: METAL SPECIFICATION ASTM A159 G3000 CAST IRON