

SURFACE APPLIED PANEL - TOP VIEW

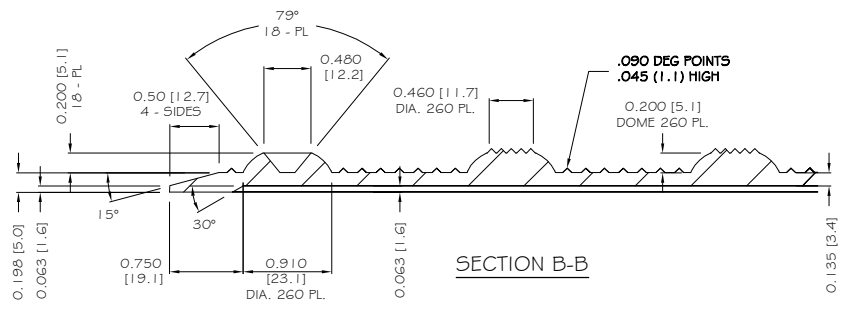
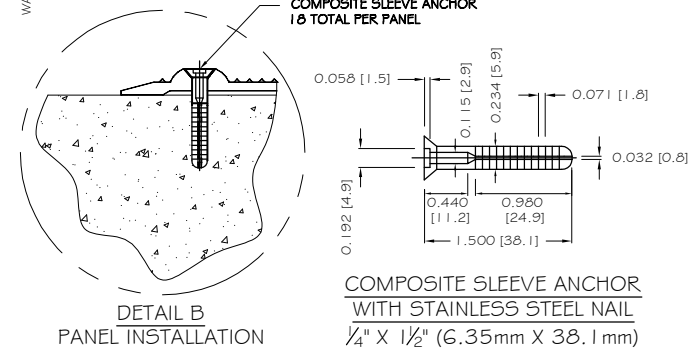
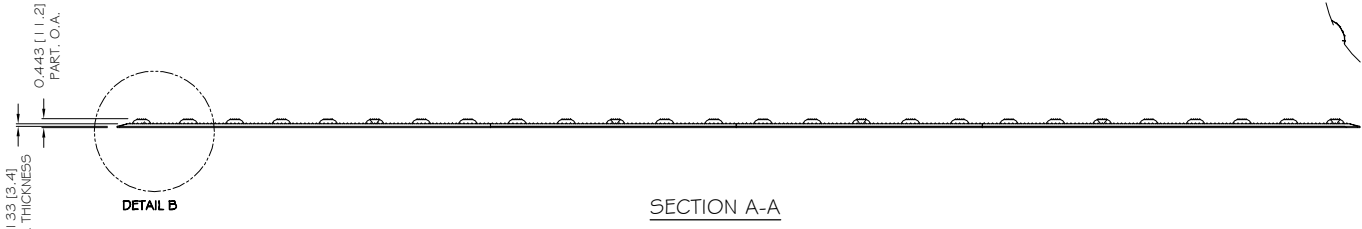
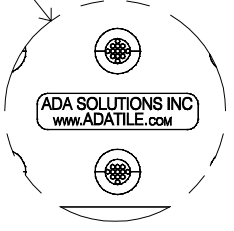
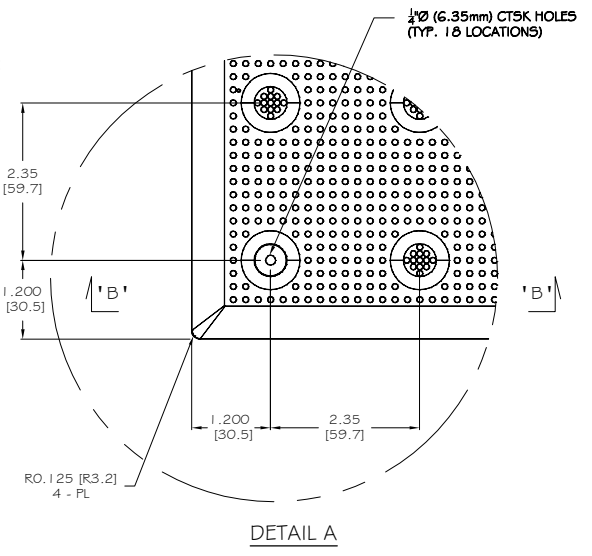

ALL DIMENSIONS NOMINAL PRIMARY DIMENSION INCHES mm IN PARENTHESES	
TRADE TACTILE WARNING SURFACE	PART NO. 2460IDRET2_
MATERIAL SMC COMPOSITE	
PROJECT SURFACE APPLIED TACTILE WARNING SURFACE PANEL 18-ANCHOR LOCATIONS 2.35" (59.7MM) IN LINE TRUNCATED DOME PART SIZE: 24" X 60" (610MM X 1524MM) PLANS AND DETAILS	
DRAWING NO. ADA-SA2460_2	DATE 06-16-17
 <p>ADA SOLUTIONS, INC. DETECTABLE WARNING SURFACES FOR PEDESTRIAN CROSSINGS</p> <p>WWW.ADATILE.COM PHONE: (800)372-0519 EMAIL: INFO@ADATILE.COM</p>	