

SURFACE APPLIED PANEL - TOP VIEW

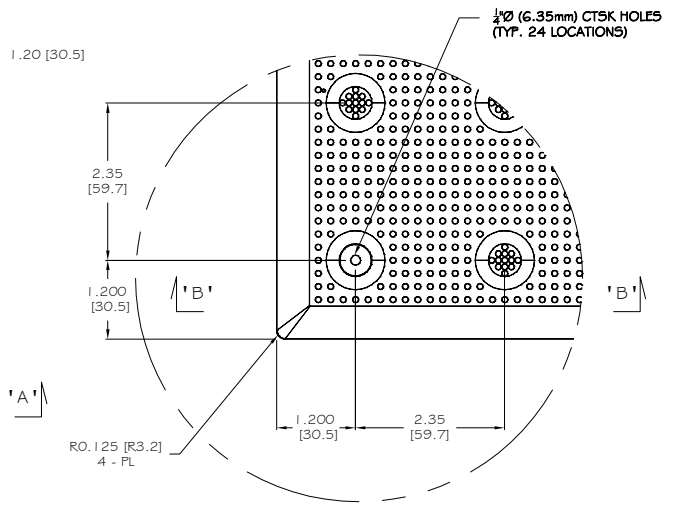

DETAIL A

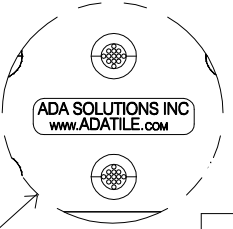

SECTION A-A

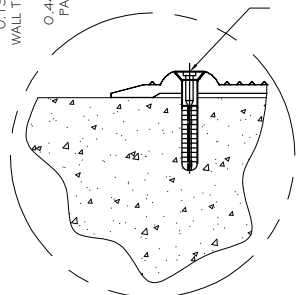

**DETAIL B
PANEL INSTALLATION**

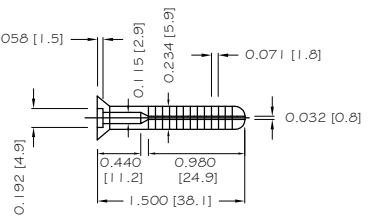

**COMPOSITE SLEEVE ANCHOR
WITH STAINLESS STEEL NAIL
1/4" X 1 1/2" (6.35mm X 38.1mm)**

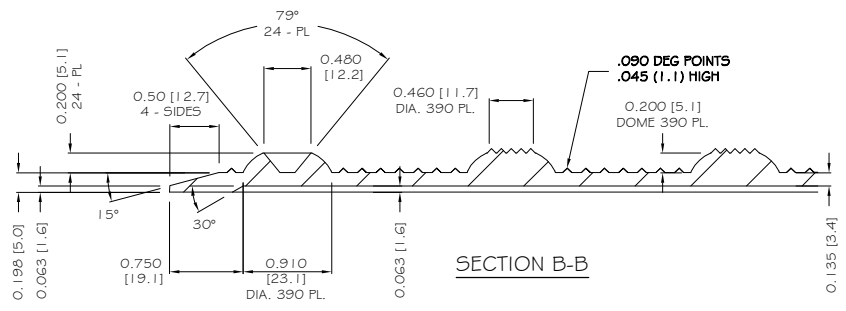

SECTION B-B

| | |
|--------------------------------------------------------------------------------------------------------------------------------------------------------------------------------------------------|-------------------------|
| ALL DIMENSIONS NOMINAL PRIMARY DIMENSION INCHES mm IN PARENTHESES | |
| TRADE TACTILE WARNING SURFACE | PART NO. 3660IDRET2_ |
| MATERIAL SMC COMPOSITE | |
| PROJECT SURFACE APPLIED TACTILE WARNING SURFACE PANEL 24-ANCHOR LOCATIONS 2.35" (59.7MM) IN LINE TRUNCATED DOME PART SIZE: 36" x 60" (914MM X 1524MM) PLANS AND DETAILS | |
| DRAWING NO. ADA-SA3660_2 | DATE 06-16-17 |
| ADA SOLUTIONS, INC. DETECTABLE WARNING SURFACES FOR PEDESTRIAN CROSSINGS WWW.ADATILE.COM PHONE: (800)372-0519 EMAIL: INFO@ADATILE.COM | |