

No. 1

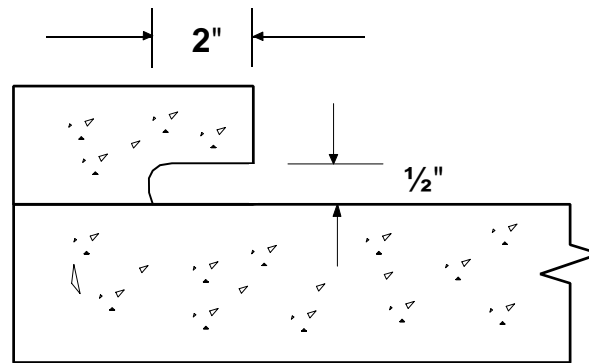

No. 2

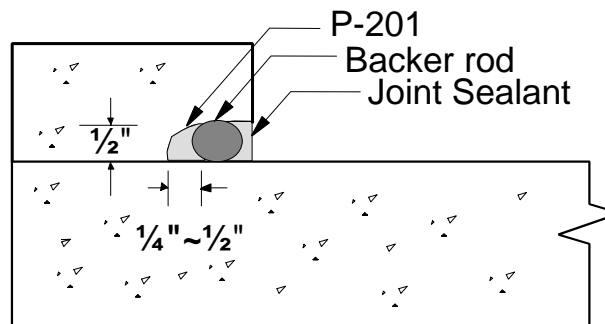

**No. 1: For P-201 repair - cut a notch  $\frac{1}{2}$ " X 2" deep**

**No. 2: For P-201 repair - apply a continuous bead of P-201 to a depth of  $\frac{1}{4}$ "~ $\frac{1}{2}$ ". Insert oversized backer rod and compress P-201 to  $\frac{1}{8}$ " ~  $\frac{1}{4}$ ". Fill remaining void with grout, epoxy or other joint filler material.**

Not to scale