

# 2-0 STRUCTURES

## TABLE OF CONTENTS

- 2-1 Overview of Structural Considerations ..... 2-2**
- 2-2 Introduction..... 2-3**
- 2-3 Design Criteria ..... 2-4**
  - Pipe Section Properties ..... 2-5
  - Material Properties..... 2-6
  - Installation Conditions and Soil Factors ..... 2-8
  - Loads ..... 2-12
- 2-4 Thermoplastic Pipe Design Procedure ..... 2-17**
  - Load and Resistance Factors..... 2-17
  - Wall Thrust ..... 2-18
  - Buckling ..... 2-21
  - Compressive Strain ..... 2-23
  - Bending Strain ..... 2-22
  - Combined Strain ..... 2-24
- 2-5 Research and Installations ..... 2-26**

### Figures

- 2-1 AASHTO H-25 and HS-25 Highway Load ..... 2-12
- 2-2 Typical and Idealized Corrugation Profiles..... 2-19

### Tables

- 2-1 General Section Properties for N-12<sup>®</sup>, N-12 STIB, and N-12 WTIB Pipe ..... 2-5
- 2-2 General Section Properties for HP Storm Pipe ..... 2-5
- 2-3 General Section Properties for SaniTite<sup>®</sup> HP Pipe ..... 2-6
- 2-4 General Section Properties for Singlewall Pipe ..... 2-6
- 2-5 Mechanical Properties for Thermoplastic Pipe ..... 2-7
- 2-6 Classes of Embedment and Backfill Materials ..... 2-10
- 2-7 Secant Constrained Soil Modulus, Ms..... 2-11
- 2-8 Shape Factors, D<sub>r</sub> ..... 2-12
- 2-9 AASHTO Highway Loads Carried by Wheel Set ..... 2-13
- 2-10 Live Load Data for AASHTO H-25, HS-25 and Cooper E-80 ... 2-14
- 2-11 Load Factors ..... 2-18
- 2-12 Resistance Factors ..... 2-18
- 2-13 Load Modifiers..... 2-18

*BUYER/USER IS RESPONSIBLE FOR SERVICEABILITY OF THE PRODUCT IN ANY GIVEN APPLICATION. SELLER IS NOT RESPONSIBLE FOR INJURY OR DAMAGE RESULTING FROM IMPROPER INSTALLATION, NONCOMPLIANCE WITH THESE GUIDELINES FOR INSTALLATION OF PRODUCT, OR USE OUTSIDE THE GUIDELINES SET FORTH HEREIN.*

## 2-1 OVERVIEW OF STRUCTURAL CONSIDERATIONS

All pipe, whether flexible or rigid, rely on the backfill structure to transfer loads into the bedding. Pipe must be installed as designed to perform as expected.

This section sets forth the design methodology for thermoplastic pipes, specifically, corrugated high density polyethylene and polypropylene pipe based on AASHTO LRFD Bridge Design Specifications Section 12: Buried Structures and Tunnel Liners (2008 Interim Revision). Section properties for both, corrugated polyethylene and corrugated polypropylene pipes are presented. Material properties, backfill criteria, and load conditions also factor into the procedure. The design procedure evaluates wall thrust, bending, buckling, and strain and establishes limits on each condition. The procedure yields conservative results and is applicable to all thermoplastic pipes. ADS is a manufacturer of both polyethylene and polypropylene products for a variety of applications. All pipe products with the exception of our HP, including HP Storm and SaniTite HP, are manufactured from high density polyethylene; our HP product lines are manufactured from polypropylene. When using this design procedure, the engineer shall specify both the product and material used in design assumptions.

Minimum and Maximum burial depths can vary greatly depending on the application, product, backfill material, and compaction level; please refer to Appendix A-5 in the *Installation* section for a listing of appropriate technical literature and standard details related to ADS products and applications. All technical literature listed in this chart is available on the ADS website or from your local ADS representative. For custom applications, contact ADS application engineering for a review of specific project needs.

Thermoplastic pipe performance has been heavily researched through the laboratory and the field. Much of this work documents the conservatism of this design procedure. Several of the research projects are briefly discussed at the end of this section. These and other materials are available through ADS.

## 2-2 INTRODUCTION

Pipe behavior can be broadly classified as flexible or rigid, depending on how it performs when installed. Flexible pipe must move, or deflect, to transfer the overburden load to the surrounding soil. ADS N-12, HP Storm, SaniTite, SaniTite HP and Singlewall pipes are all examples of flexible pipe. Flexible pipe, therefore, is not designed to carry overburden loads directly. Rigid pipe is commonly defined as a pipe that does not deflect more than 2% without structural distress, and as such, it must be designed to carry the majority of the load directly. Reinforced and non-reinforced concrete pipe are both examples of rigid pipe.

Both flexible and rigid pipe depend on proper backfill. In the case of flexible pipe, deflection allows loads to be transferred to and carried by the backfill. Rigid pipe transmits most of the load through the pipe wall into the bedding. In both cases, proper backfill is very important in allowing this load transfer to occur.

Many research projects have investigated the behavior of flexible pipe. Thermoplastic pipe performance has been investigated through use of actual field installations, post-installation inspections, load cell tests, and finite element computer analyses. Now, three decades after its introduction, the behavior of thermoplastic pipe, including corrugated polyethylene and corrugated polypropylene pipes, has probably been analyzed more than any other conventional drainage pipe.

The information in subsequent areas of this section provides a step-by-step guide for the structural design of nonpressure corrugated polyethylene and polypropylene pipe. The methodology is based on the AASHTO design procedure, and has been proven through test installations and actual projects to be highly conservative. More discussion on actual installations is included in Section 2-5.

## 2-3 DESIGN CRITERIA

Design of thermoplastic pipe requires an understanding of pipe section properties, material properties, installation conditions, and the loading situation. All of these elements define the behavior of the pipe in some respect. This section describes the criteria that enter into the design procedure presented in Section 2-4.

### PIPE SECTION PROPERTIES

As in the design of other structural components, the shape of the pipe profile helps determine how it will perform in the pipe/soil structure. Pipe properties include the moment of inertia of the wall profile ( $I$ ), distance from the inside diameter to the neutral axis ( $c$ ), and the section area of a longitudinal section ( $A_s$ ). Pipe stiffness ( $PS$ ) is a measure of the flexibility of a prescribed length of pipe and is measured in the laboratory by gauging the force required to deflect the pipe 5% of its inside diameter. Pipe stiffness is primarily a quality check not used directly in the design procedure and should not be interpreted to be a limiting pipe property. General properties of N-12, N-12 STIB, and N-12 WTIB are shown in Table 2-1, HP Storm in Table 2-2, SaniTite HP in Table 2-3, and Singlewall pipes are shown in Table 2-4. In order to complete design calculations listed in this structures section, general profile properties in conjunction with detailed section properties are necessary. Detailed section properties by product type and by diameter are found in ADS Product Notes 2.01 thru 2.05; please contact an ADS representative for this information.

**Table 2-1**  
**General Section Properties for N-12, N-12 ST IB, and N-12 WT IB Pipe**

Nominal Pipe Diameter		Outside Diameter, OD		Pipe Stiffness, PS	
in	mm	in	mm	p <sub>ii</sub>	kPa
4	100	4.8	121	50	340
6	150	6.9	175	50	340
8	200	9.1	231	50	340
10	250	11.4	290	50	340
12	300	14.5	368	50	345
15	375	18.0	457	42	290
18	450	22.0	559	40	275
24	600	28.0	711	34	235
30	750	36.0	914	28	195
36	900	42.0	1067	22	150
42	1050	48.0	1219	20	140
48	1200	54.0	1372	18	125
54	1350	61.0	1549	16	110
60	1500	67.0	1702	14	97

**Table 2-2**  
**General Section Properties for HP Storm Pipe**

Nominal Pipe Diameter		Outside Diameter, OD		Pipe Stiffness, PS	
in	mm	in	mm	P <sub>ii</sub>	kPa
12	300	14.5	368	75	520
15	375	17.7	450	60	411
18	450	21.4	544	56	385
24	600	28.0	711	50	343
30	750	35.5	902	46	320
36	900	41.5	1054	40	275
42	1050	47.4	1204	35	241
48	1200	54.1	1374	35	241
60	1500	67.1	1704	30	207

**Table 2-3**  
**General Section Properties for SaniTite HP Sanitary Pipe**

Profile Type	Nominal Pipe Diameter		Outside Diameter, OD		Pipe Stiffness, PS	
	in	mm	in	mm	pil	kPa
Dual Wall	12	300	14.5	368	46	320
	15	375	17.6	447	46	320
	18	450	21.2	538	46	320
	24	600	28.0	711	46	320
	30	750	35.5	902	46	320
Triple Wall	30	750	35.5	902	46	320
	36	900	41.5	1054	46	320
	42	1050	47.4	1199	46	320
	48	1200	54.1	1374	46	320
	60	1500	67.1	1705	46	320

\* OD values listed above are NOT for manhole connector sizing. See ADS Standard Detail 205A-F for the recommended manhole connector based on product and diameter.

**Table 2-4**  
**General Section Properties for Singlewall Pipe**

Nominal Pipe Diameter		Outside Diameter, OD		Pipe Stiffness, PS	
in.	mm.	in.	mm	pil	kPa
3	75	3.6	91	35	240
4	100	4.6	117	35	240
6	150	7.0	178	35	240
8	200	9.5	241	35	240
10	250	12.0	305	35	240
12	300	14.5	368	50	340
15	375	18.0	457	42	290
18	450	22.0	559	40	275
24	600	28.0	711	34	235

Thermoplastic pipe products made by other manufacturers may have slightly different section properties depending on their design. Data for those products should be obtained from the respective manufacturer for use in this design procedure.

## MATERIAL PROPERTIES

Behavior of viscoelastic materials differs from elastic materials like steel. When polyethylene and polypropylene are subjected to a constant force, the stress/strain curve that results gives the impression that the material loses strength with time. Tests that describe perfectly the behavior of elastic materials can, and in this case do, provide misleading results when used on viscoelastic materials.

Tests show that polyethylene and polypropylene do not weaken over time. The same stress/strain curve for the material can be duplicated repeatedly. What remains unaccounted for in the test is stress relaxation, which is a property unique to viscoelastics. Stress relaxation is decay in stress under a constant strain. In other words, a pipe that is held in a deflected position will initially experience relatively high stress levels that then quickly subside. Additional deflection causes a similar response: stress levels increase, and then soon decrease. This phenomenon has been documented in the laboratories at the University of Massachusetts. Tests there showed that when the pipe was held in a deflected position, the apparent modulus decreased. When deflection was increased, the pipe responded with a much higher modulus. (Additional information regarding this research is located in Section 2-5.)

Accounting for the time-dependent behavior in the design of thermoplastic pipe can become cumbersome. The procedure described in Section 2-5 explains how and when to use short term or long term material properties. See table 2-5 for materials properties list of polyethylene and polypropylene.

(Note: The tensile strength is used in some design computations although the predominant wall forces are compressive. Tests to determine the maximum compressive strength of polyethylene and polypropylene have to date been inconclusive because of a lack of a definite failure point or limit. However, the *ASCE Structural Plastics Design Manual* states "A general rule is that compressive strength of plastics is greater than tensile strength." Use of the tensile strength in design in lieu of the more appropriate compressive strength will yield conservative results. (*ASCE Manuals and Reports on Engineering Practice No. 63, ASCE: NY, NY, 1984, p. 163.*))

**Table 2-5  
Mechanical Properties for Thermoplastic Pipe<sup>1</sup>**

Product	Material	Allowable Strain, %	Initial		75-Year	
			F <sub>u</sub> psi (MPA)	E psi (MPA)	F <sub>u</sub> psi (MPA)	E psi (MPA)
N-12 ST IB, WT IB, Plain End, SaniTite, Low Head	Polyethylene	5	3000 (20.7)	110000 (758)	900 (6.21)	21000 (144)
N-12 HP Storm and SaniTite HP Sanitary	Polypropylene	4	3500 (24.1)	175000 (1206)	1000 (6.89)	28000 (193)

## INSTALLATION CONDITIONS AND SOIL FACTORS

The structural performance of pipe depends on the interaction between the embedment, or backfill envelope, and the pipe, and is commonly referred to as pipe/soil interaction. The backfill envelope must provide structural and drainage characteristics appropriate for the application. Structural considerations of the backfill include the type of material and compaction level, dimensions of the backfill envelope, and native soil conditions. The information presented here is, with few exceptions, consistent with requirements established in ASTM D2321 "Standard Practice for Underground Installation of Thermoplastic Pipe for Sewers and Other Gravity-Flow Applications." Additional information regarding dimensions of the backfill envelope and native soil considerations are discussed in more detail in the *Installation* section (Section 5) of the Drainage Handbook.

The type of material (sand, gravel, clay, etc.) and compaction level (standard Proctor density) determine overall strength of the backfill. As a general rule, material particles that are relatively large and angular require less compaction than particles that are smaller and less angular to produce structures having equal strength.

The strength of the backfill can be described using different parameters. One way is by describing it in terms of the modulus of soil reaction ( $E'$ ), which is an empirical value developed by the Bureau of Reclamation to calculate deflection. Another parameter used to describe backfill strength is the secant constrained soil modulus ( $M_s$ ). Although this property can be measured in the laboratory, values appropriate for design are shown in Table 2-7. This value must be used in the following calculations. While  $E'$  and  $M_s$  do have similar units, they are not considered interchangeable.

The native soil and other locally available materials may be considered for backfill. If they meet the criteria of Table 2-6 and Table 2-7, they may be acceptable materials and should be considered to minimize material and hauling costs. When in doubt about the appropriate material to use in an installation, consult an ADS engineer.

Mechanical compaction is not always necessary; some backfill materials can be dumped and others can meet minimum compaction criteria simply by being walked in around the pipe. On the other hand, mechanical compaction can make placement of some backfill materials much faster. Additional information regarding the types of mechanical compactors available and the soil types with which they work best is located in the *Installation* section (Section 5).

Another backfill material that has gained in application over the past few years is flowable fill. This material is similar to a very low strength concrete. It is poured around the pipe and hardens to form a solid backfill structure. The final cured strength of this material is highly dependent on mix design and should be determined by the design engineer. In order to take advantage of the strength of this material, the backfill strength of the surrounding native material must be adequate.



Where flowable fill is used, soft materials must be over-excavated and replaced with suitable bedding and side fill material. The major disadvantages of this material are that it can be very costly both in terms of material costs and installation time, and it will cause the pipe to float if precautions are not taken. Properly designed and installed, however, it can be used as an alternative to typical granular backfill. ADS engineers and some textbooks can provide additional guidance in the use of this material.

**Table 2-6**  
**Classes of Embedment and Backfill Materials**

ASTM D2321 <sup>(A)</sup> Class	Description	Notation	ASTM D2487 Description	AASHTO M43 Notation	AASHTO M145 Notation	ASTM D2321 <sup>(A)</sup>							
						Percentage Passing Sieve Sizes				Atterberg Limits		Coefficients	
						1 ½ in. (40mm)	No. 4 (4.75mm)	3/8" (9.5mm)	No. 200 (0.075mm)	LL	PI	Cu	Cc
I <sup>(B)</sup>	Crushed rock, angular <sup>C</sup>	N/A	Angular crushed stone or rock, crushed gravel, crushed slag; large voids with little or no fines	5, 56, 57 <sup>(D)</sup> , 6, 67 <sup>(D)</sup>	N/A	100%	≤15%	<25%	<12%	Non Plastic		N/A	
II	Clean, coarse- grained soils	GW	Well-graded gravel, gravel-sand mixtures; little or no fines	5, 6	A1, A3	100%	<50% of "Coarse Fraction"	-	<5%	Non Plastic	>4	1 to 3	
		GP	Poorly-graded gravels, gravel-sand mixtures; little or no fines	56, 57, 67							<4	<1 or >3	
		SW	Well-graded sands, gravelly sands; little or no fines								>6	1 to 3	
		SP	Poorly-graded sands, gravelly sands; little or no fines								<6	<1 or >3	
	Coarse-Grained Soils, borderline clean to w/fines	GW-GC, SP-SM	Sands and gravels which are borderline between clean and with fines	N/A			100%	Varies	-	5% to 12%	Non Plastic	Same as for GW, GP, SW and SP	
III	Coarse-grained soils with fines	GM	Silty gravels, gravel-sand- silt mixtures	Gravel & sand with <10% fines	A-2-4, A- 2-5, A-2- 6, or A-4 or A-6 soils with more than 30% retained on #200 sieve	100%	<50% of "Coarse Fraction"	-	12% to 50%	N/A	<4 or <"A" Line	N/A	
		GC	Clayey gravels, gravel- sand-clay mixtures								<7 & >"A" Line		
		SM	Silty sands, sand-silt mixtures								>4 or <"A" Line		
		SC	Clayey sands, sand-clay mixtures								>7 & >"A" Line		
	Inorganic fine- grained soils	ML	Inorganic silts and very fine sands, rock flour, silty or clayey fine sands, silts with slight plasticity			100%				> 30% (Retained)	<50		<4 or <"A" Line
		CL	Inorganic clays of low to medium plasticity; gravelly, sandy, or silty clays; lean clays										> 30% (Retained)
IV <sup>(E)</sup>	Inorganic fine- grained soils	ML	Inorganic silts and very fine sands, rock flour, silty or clayey fine sands, silts with slight plasticity	N/A	A-2-7 or A-4 or A- 6 soils with 30% or less retained on #200 sieve	100%	100%	-	< 30% (Retained)	<50	<4 or <"A" Line	N/A	
		CL	Inorganic clays of low to medium plasticity; gravelly, sandy, or silty clays; lean clays	N/A						>7 & >"A" Line			
V	Inorganic fine- grained soils	MH	Inorganic silts, micaceous or diatomaceous fine sandy or silty soils, elastic silts	N/A	A5, A7	100%	100%	-	>50%	>50	<"A" Line	N/A	
		CH	Inorganic clays of high plasticity, fat clays	N/A							>"A" Line		
	Organic soils or Highly organic soils	OL	Organic silts and organic silty clays of low plasticity	N/A		100%	100%	-	>50%	>50	<4 or <"A" Line	N/A	
		OH	Organic clays of medium to high plasticity, organic silts	N/A							>50		<"A" Line
		PT	Peat and other high organic soils	N/A									

Notes:

- A) Refer to ASTM D2321 for more complete soil descriptions.
- B) Class I materials allow for a broader range of fines than previous versions of D2321. When specifying Class I material for infiltration systems, the engineer shall include a requirement for an acceptable level of fines.
- C) All particle faces shall be fractured.
- D) Assumes less than 25% passes the 3/8" sieve.
- E) Class IV materials require a geotechnical evaluation prior to use and should only be used as backfill under the guidance of a qualified engineer.

**Table 2-7**  
**Secant Constrained Soil Modulus,  $M_s$**

Soil Type and Compaction Level (standard Proctor density)									
	Class I Crushed Stone		Class II Gravelly Sand				Class III Sandy Silt		
	compacted	uncompacted	GW, GP, SW, SP				GM, SM, ML <sup>(1)</sup> and GC and SC with <20% passing the 200 sieve		
Geostatic Load $P_{sp}$ Equation 2-1									
	100%	95%	90%	85%	95%	90%	85%		
psi (MPa)	psi (MPa)	psi (MPa)	psi (MPa)	psi (MPa)	psi (MPa)	psi (MPa)	psi (MPa)	psi (MPa)	psi (MPa)
1.04 (0.007)	2350 (16.20)	1275 (8.79)	2350 (16.20)	2000 (13.79)	1275 (8.79)	470 (3.24)	1415 (9.76)	670 (4.17)	360 (2.48)
5.21 (0.036)	3450 (23.79)	1500 (10.34)	3450 (23.79)	2600 (17.93)	1500 (10.34)	520 (3.59)	1670 (11.51)	740 (5.10)	390 (2.69)
10.42 (0.072)	4200 (28.96)	1625 (11.20)	4200 (28.96)	3000 (20.68)	1625 (11.20)	570 (3.93)	1770 (12.20)	750 (5.17)	400 (2.76)
20.83 (0.144)	5500 (37.92)	1800 (12.41)	5500 (37.92)	3450 (23.79)	1800 (12.41)	650 (4.48)	1880 (12.96)	790 (5.45)	430 (2.97)
41.67 (0.287)	7500 (51.71)	2100 (14.48)	7500 (51.71)	4250 (29.30)	2100 (14.48)	825 (5.69)	2090 (14.41)	900 (6.21)	510 (3.52)
62.50 (0.431)	9300 (64.12)	2500 (17.24)	9300 (64.12)	5000 (34.47)	2500 (17.24)	1000 (6.89)			

Notes:

- 1)  $M_s$  values presented in the table assume that the native material is at least as strong as the intended backfill material. If the native material is not adequate, it may be necessary to increase the trench width. Refer to the *Installation* section (Section 5) for information on over excavation.
- 2)  $M_s$  may be interpolated for intermediate cover heights.
- 3) For  $M_s$  values of Class IV materials, contact ADS Application Engineering.

Another soil property used in design, the shape factor ( $D_f$ ), is a function of pipe stiffness, type of backfill material, and the compaction level. The shape factor relates deflection and bending behaviors. Table 2-8 lists shape factors for a variety of typical installation conditions.

**Table 2-8  
Shape Factors,  $D_f$**

Pipe Stiffness, $PS^{(1)}$ $pii$ (kPa)	Gravel GW, GP, GW-GC, GW-GM, GP-GC and GP-GM (includes crushed stone)		Sand SW, SP, SM, SC, GM, GC or mixtures	
	Dumped to Slight (<85% SPD)	Moderate to High (≥85% SPD)	Dumped to Slight (<85% SPD)	Moderate to High (≥85% SPD)
14 (97)	4.9	6.2	5.4	7.2
16 (110)	4.7	5.8	5.2	6.8
18 (125)	4.5	5.5	5.0	6.5
20 (140)	4.4	5.4	4.9	6.4
22 (150)	4.3	5.3	4.8	6.3
28 (195)	4.1	4.9	4.4	5.9
34 (235)	3.9	4.6	4.1	5.6
35 (240)	3.8	4.6	4.1	5.6
40 (275)	3.7	4.4	3.9	5.4
42 (290)	3.7	4.4	3.9	5.3
46 (320)	3.7	4.3	3.9	5.2
50 (345)	3.6	4.2	3.8	5.1
72 (496)	3.3	3.8	3.5	4.5

Notes:

- 1) Interpolate for intermediate pipe stiffness values.
- 2) For other backfill materials, use the highest shape factor for the pipe stiffness.
- 3) Modified from AASHTO LRFD Section 12, 2008, Table 12-12-3-5-4b-1.

## LOADS

Loads are considered to be either a live load or a dead load. Live loads change in position or magnitude, whereas dead loads remain constant throughout the design life of the drainage system. The most commonly considered live loads in pipe applications are vehicular loads, usually from trucks, railroads, and aircraft. The soil load is often the sole dead load consideration; however forces from high groundwater, surcharge, and foundations are also types of dead loads and should be incorporated into the design when appropriate.

### LIVE LOADS

Vehicular loads are based on the AASHTO H- or HS- vehicle configurations. Figure 2-1 represents the two types of design truck configurations and the associated loading distribution. Table 2-9 provides the critical controlling load that is exerted at each wheel set or tire area, from the design truck configurations represented in Figure 2-1 or a design tandem rear axle truck (not shown). In railroad applications, the standard load is represented by the Cooper E-80 configuration at 80,000 lbs/ft (1167 kN/m) of track.

**Figure 2-1**  
**AASHTO Highway Loads**

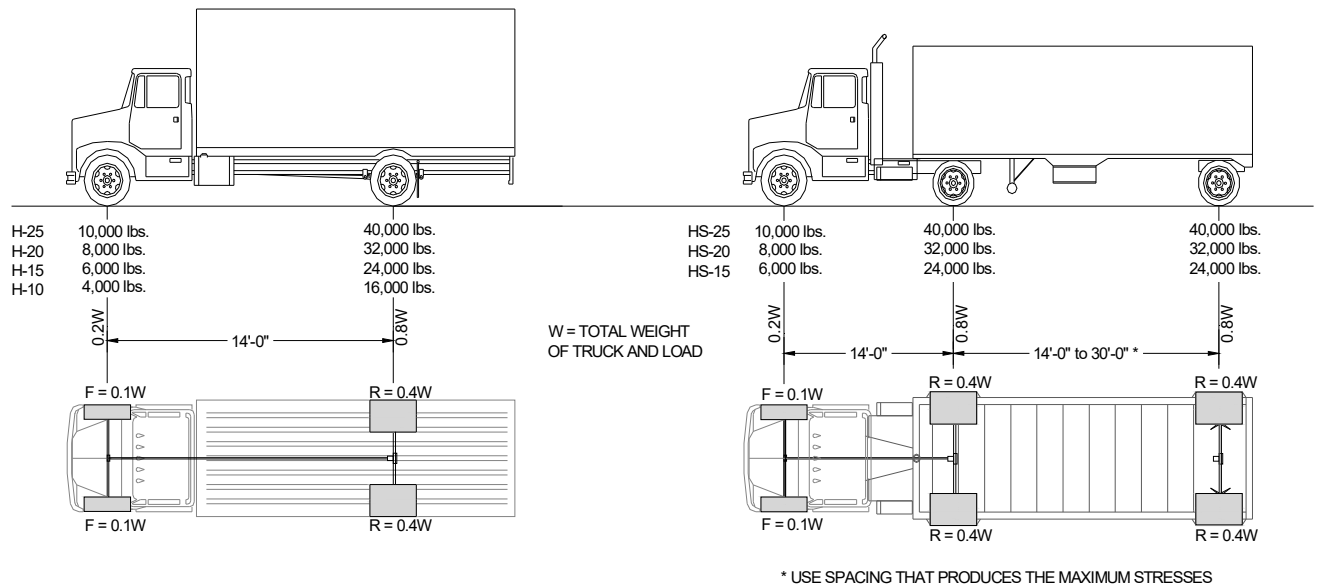

Source: AASHTO Standard Specifications for Highway Bridges

**Table 2-9**  
**AASHTO Highway Loads Carried by Wheel Set**

	H-10 lbs (kN)	H-15 or HS-15 lbs (kN)	H-20 or HS-20 lbs (kN)	H-25 or HS-25 lbs (kN)
<b>W</b>	20,000 (89.0)	30,000 (133.4)	40,000 (178.0)	50,000 (222.4)
<b>F</b>	2,000 (8.9)	3,000 (13.3)	4,000 (17.8)	5,000 (22.2)
<b>R</b>	8,000 (35.6)	12,000 (53.4)	16,000 (71.2)	20,000 (89.0)
<b>R<sub>AXEL</sub></b>	16,000 (71.1)	24,000 (106.7)	32,000 (142.3)	40,000 (177.9)

Note: "F" and "R" are represented in Figure 2-1. R<sub>AXEL</sub> represents the truck's axel load

In applications where the pipe is buried relatively shallow it can experience an additional force from the rolling motion of the vehicle. To account for this additional force, the stationary vehicular load is multiplied by an 'impact factor.' For determination of impact factor for highway loads, AASHTO provides the following equation.

$$IM = 33(1.0 - 0.125H) \geq 0\% \quad \text{Equation 2-1}$$

Where:

IM = impact factor, %  
H = burial depth, ft

Table 2-10 provides information about the resultant H-25 and E-80 vehicular forces at various cover heights with impact included in the shallow cover situations. Resultant loads for H-20 vehicles can be estimated by decreasing the values in Table 2-10 by 20%. These values are widely used throughout the industry, although values based on alternative computation methods can be substituted.

The intensity of the vehicular load decreases as the depth increases, conversely, the area over which the force acts increases. As shown in Table 2-10, for H-25 loading, live load is negligible beyond 8-feet of fill. Table 2-9 lists the live load distribution width showing this relationship for an AASHTO H-25 or HS-25 load. This width is based on AASHTO information and assumes that the pipe is installed perpendicular to the direction of traffic. Other AASHTO H or HS loads would have identical live load distribution widths. If desired, alternative ways of calculating this value may be used.

**Table 2-10**  
**Live Load Data for AASHTO H-25, HS-25, and Cooper E-80**

Cover, ft. (m)	AASHT O H-25 or HS-25 <sup>(1)</sup>		Cooper E-80 <sup>(1)</sup>	Cover, ft. (m)	AASHTO H-25 or HS-25 <sup>(1)</sup>		Cooper E-80 <sup>(1)</sup>
	Live Load Transferred to Pipe, psi (MPa)	Live Load Distribution Width, L <sub>w</sub> in. (mm)	Live Load Transferred to Pipe, psi (MPa)		Live Load Transferred to Pipe, psi (MPa)	Live Load Distribution Width, L <sub>w</sub> In. (mm)	Live Load Transferred to Pipe, psi (MPa)
1 (0.3)	32.0 (0.220)	34 (860)	N/R	14 (4.3)	negligible	N/A	4.17 (0.288)
2 (0.6)	13.9 (0.958)	48 (1210)	26.39 (0.182)	16 (4.9)	negligible	N/A	3.47 (0.239)
3 (0.9)	7.6 (0.524)	61 (1561)	23.61 (0.163)	18 (5.5)	negligible	N/A	2.78 (0.192)
4 (1.2)	4.9 (0.338)	147 (3740)	18.40 (0.127)	20 (6.1)	negligible	N/A	2.08 (0.143)
5 (1.5)	3.5 (0.241)	161 (4090)	16.67 (0.115)	22 (6.7)	negligible	N/A	1.91 (0.132)
6 (1.8)	2.7 (0.186)	175 (4441)	15.63 (0.108)	24 (7.3)	negligible	N/A	1.74 (0.120)
7 (2.1)	2.1 (0.145)	189 (4791)	12.15 (0.838)	26 (7.9)	negligible	N/A	1.39 (0.095)
8 (2.4)	1.6 (0.110)	202 (5142)	11.11 (0.766)	28 (8.5)	negligible	N/A	1.04 (0.072)
10 (3.0)	negligible	N/A	7.64 (0.527)	30 (9.1)	negligible	N/A	0.69 (0.048)
12 (3.7)	negligible	N/A	5.56 (0.383)	35 (10.7)	negligible	N/A	negligible

- 1) Includes impact.
- 2) N/R indicates that the cover height is not recommended.
- 3) N/A indicates that the information is not applicable.

Loads from aircraft vary widely in magnitude and distribution. The FAA Design Manual should be referenced for more specific information. Some construction vehicles may pose a temporary, although severe, live load consideration. On the other hand, other construction vehicles may weigh substantially less than the design load. For very large loads, mounding additional cover over the pipe when necessary, then grading following construction may be warranted in situations where the pipe has little cover. Construction vehicles with loads lighter than the design load may be permitted over the pipe, during the construction phase only, with less than the minimum recommended cover. Construction loads are covered in additional detail in the *Installation* section (Section 5).

## DEAD LOADS

The soil load is calculated in this design procedure using a soil arch load ( $W_{sp}$ ). Rather than using a soil column load, the actual soil load is less than the calculated column load because the column is supported, in part, by adjacent soil columns.

### Soil Arch Load ( $W_{sp}$ )

The soil arch load ( $W_{sp}$ ) most closely represents the actual soil load experienced by a flexible pipe. The arch load calculation uses a vertical arching factor (VAF) to reduce the earth load in order to account for the support provided by adjacent soil columns.

The arch load is determined using the procedure described below. First, the geostatic load is calculated by determining the weight of soil directly above the outside diameter of the pipe plus a small triangular load extending just beyond the outside diameter. The equation for the geostatic load,  $P_{sp}$ , is shown in Equation 2-2.

$$P_{sp} = \frac{(\gamma_s) \left( H + 0.11 \frac{OD}{12} \right)}{144} \quad \text{Equation 2-2}$$

Where:

$P_{sp}$  = geostatic load, psi

H = burial depth, ft

$\gamma_s$  = unit weight of soil, pcf

OD = outside diameter of pipe, in (Table 2-1 - 2-4)

Next, the vertical arching factor (VAF) must be determined. This factor accounts for the support provided by adjacent soil columns by reducing the geostatic load. The vertical arching factor is computed as shown in Equation 2-3.

$$\text{VAF} = 0.76 - 0.71 \left( \frac{S_h - 1.17}{S_h + 2.92} \right) \quad \text{Equation 2-3}$$

Where:

VAF = vertical arching factor, unitless

$S_h$  = hoop stiffness factor;

=  $\phi_s M_s R / (E A)$

$\phi_s$  = capacity modification factor for soil, 0.9

$M_s$  = secant constrained soil modulus, psi (Table 2-7)

R = effective radius of pipe, in

=  $ID/2+c$

ID = inside diameter of pipe, in (Table 2-1 - 2-4)

- $c$  = distance from inside diameter to neutral axis, in  
 (Product Note 2.01 thru 2.05)  
 $E$  = modulus of elasticity, psi initial and long term (Table 2-5)  
 $A$  = section area, in<sup>2</sup>/in (mm<sup>2</sup>/mm) (Product Note 2.01 - 2.05)

After the geostatic load,  $P_{sp}$ , and the VAF have been determined the soil arch load can be found as shown in Equation 2-4.

$$W_{sp} = (P_{sp})(VAF) \quad \text{Equation 2-4}$$

Where:

- $W_{sp}$  = soil arch load, psi  
 $P_{sp}$  = geostatic load, psi  
 VAF = vertical arching factor, unitless

### Hydrostatic Loads

The pressure of groundwater must also be accounted for only if present at or above the pipe springline. Equations 2-5 provide the method to calculate hydrostatic pressure. Where hydrostatic pressure is present, the geostatic load ( $P_{sp}$ ) should be adjusted to account for the buoyant weight of the soil in the saturated zone.

$$P_w = \frac{\gamma_w (H_s)}{144} \quad \text{Equation 2-5}$$

Where:

- $P_w$  = hydrostatic pressure at springline of pipe, psi  
 $\gamma_w$  = unit weight of water, 62.4 pcf  
 $H_s$  = height of groundwater above springline of pipe, ft



### Foundation Loads

In some custom pipe installations, pipes are positioned beneath or near foundations. Where this type of installation is permitted, this load contribution must be added to the dead load before proceeding with the design process. Soil mechanics textbooks include procedures to determine the effect of foundation loads some distance away from the point of application. ADS does not recommend pipe being installed parallel to a foundation load, where the pipe is positioned within the influence line of the foundation.

## 2-4 THERMOPLASTIC PIPE DESIGN PROCEDURE

This section sets forth the design methodology for corrugated polyethylene and polypropylene pipe based on AASHTO Load and Resistance Factor Design (LRFD) Bridge Design Specifications Section 12: Buried Structures and Tunnel Liners (2008 Interim Revision). Design of corrugated polyethylene and polypropylene pipe in non-pressure applications involves calculating wall thrust, bending strain, buckling, and strain limits based on combined tension and compressive conditions. Criteria for pipe, installation conditions, and loads from Section 2-3 are required for this procedure; references are made to areas where the required information can be found. Minimum and Maximum burial depths depend on the application, product, backfill material, and compaction level; please refer to the Appendix A-5 in the *Installation* section for a listing of appropriate technical literature and standard details related to ADS products and applications. All technical literature listed in this chart is available on the ADS website. Contact ADS for any installations with deep fill heights or custom applications.

In this design procedure, the pipe is evaluated at various limit states to ensure the objectives of constructability, safety, and serviceability are obtained. The pipe is first analyzed for the service limit states with restrictions on stress and deformation. Next the pipe is evaluated at strength limit states for wall area, buckling, thrust, and combined strain. Each condition is evaluated to ensure that strength and stability, both global and locally, are provided to resist the specified load combinations expected.

## LOAD AND RESISTANCE FACTORS

In Load and Resistance Factor Design (LRFD), the loads applied to the structure and the resistance of a given structure or element to resist the load are multiplied by modification factors to introduce a factor of safety to each criterion. While modification factors are generally provided in the design method, it is left up to the user to choose between a range of factors for a given application. As stated by AASHTO, "Factors have been developed from the theory of reliability based on current statistical knowledge of loads and structural performance." These factors should be chosen based on the criterion they are applied to and the severity of the application.

Tables 2-11 thru 2-13 below provide modification factors which are used throughout this design method. Within each equation that follows, references to these tables will be provided with a recommended modification factor where appropriate.

**Table 2-11**  
**Load Factors ( $\gamma$ )**

Load Combination Limit State	Vertical Earth Pressure $\gamma_{EV}$	Water Load $\gamma_{WA}$	Vehicular Live Load $\gamma_{LL}$
Strength Limit I	0.9-1.95	1.0-1.3	1.75
Strength Limit II	0.9-1.95	1.0-1.3	1.35
Service Limit I	1.0	1.0	1.0

**Table 2-12**  
**Resistance Factors ( $\phi$ )**

Structure Type	$\phi$
Min Wall Area	1.0
Buckling	1.0
Flexure	1.0
Pipe	1.0
Soil	0.9

**Table 2-13**  
**Load Modifiers ( $\eta$ )**

Load Combination	$\eta$	Redundancy
Earth Fill	1.05	Non-redundant
Live Load	1.0	Redundant
Construction Load	1.0	Redundant

## WALL THRUST

Thrust, or stress, in the pipe wall is determined by the total load on the pipe including soil loads, vehicular loads, and hydrostatic forces. The pipe must be able to withstand these forces in both tension and compression in order for it to remain structurally stable. The critical wall thrust ( $T_{cr}^{ten}$ ), determined in Equation 2-9 and the critical wall thrust for compression ( $T_{cr}^{comp}$ ) determined in Equation 2-10, must be equal to or greater than the wall thrust ( $T_L$ ) calculated in Equations 2-8.

Since thrust is later used for the purpose of determining strain, it is recommended in this step of the design procedure to calculate both a short term and long term thrust component using short term and long term loading conditions respectfully. For the trust comparison of critical wall thrust to actual wall thrust, the short term and long term thrust components can simply be added together for analysis.

**Calculated Wall Thrust****Short Term Thrust**

$$T_{L-s} = (\eta_{LL} \gamma_{LL} P_l C_l) \left( \frac{OD}{2} \right) \quad \text{Equation 2-6}$$

**Long Term Thrust**

$$T_{L-L} = \left[ \eta_{EV} (\gamma_{EV} W_{sp} + \gamma_{WA} P_w) \right] \left( \frac{OD}{2} \right) \quad \text{Equation 2-7}$$

**Combined Thrust**

$$T_L = T_{L-L} + T_{L-s} \quad \text{Equation 2-8}$$

Where:

$T_{L-s}$  = factored wall thrust due to short term loading, lb/in

$T_{L-L}$  = factored wall thrust due to long term loading, lb/in

$T_L$  = factored wall thrust, lb/in

$W_{sp}$  = soil arch load, psi (Equation 2-3)

$\eta_{EV}$  = load modifier, earth fill, (Table 2-12)

$\gamma_{EV}$  = load factor, vertical earth pressure, (Table 2-11)

$\gamma_{WA}$  = load factor, water load (Table 2-11)

$\eta_{LL}$  = load modifier, live load (Table 2-13)

$\gamma_{LL}$  = load factor, live load (Table 2-11)

$P_l$  = live load transferred to pipe, psi (Table 2-10)

$C_l$  = live load distribution coefficient

= the lesser of  $\frac{L_w}{OD}$  or 1.0

$L_w$  = live load distribution width at the crown, in (Table 2-10)

$OD$  = outside diameter, in (Table 2-1 - 2-4)

$P_w$  = hydrostatic pressure at springline of pipe, psi (Equation 2-5)

Actual thrust calculated ( $T_L$ ) is a compressive thrust. An internal load, such as internal pressure, would have to result in a tensile thrust greater than the compressive thrust calculated here in order for tensile thrust to be greater than zero. The actual tensile thrust is 0psi for corrugated pipe installed under typical installation conditions.

**Tensile Resistance to Thrust**

$$T_{cr}^{ten} = (F_y)(A)(\phi_p) \quad \text{Equation 2-9}$$

Where:

$T_{cr}^{ten}$  = critical wall thrust resistance in tension, lb/linear inch of pipe

$F_y$  = tensile strength, psi initial or long term (Table 2-5)

A = wall area, in<sup>2</sup>/inch of pipe (Product Note 2.01 – 2.05)  
 ϕ<sub>p</sub> = capacity modification factor for pipe, 1.0 (Table 2-11)

**Compressive Resistance to Thrust**

$$T_{cr}^{comp} = (F_y)(A_{eff})(\phi_p) \tag{Equation 2-10}$$

Where:

T<sub>cr</sub><sup>comp</sup> = critical wall thrust resistance in compression, lb/linear inch of pipe

F<sub>y</sub> = tensile strength, psi initial or long term (Table 2-5)

A<sub>eff</sub> = effective wall area, in<sup>2</sup>/inch of pipe (Equation 2-11)

ϕ<sub>p</sub> = capacity modification factor for pipe, 1.0 (Table 2-12)

**Effective Area (A<sub>eff</sub>)**

The effective area of a profile wall flexible pipe is the amount of total area which is “effective” in withstanding a given compressive force in the pipe wall. Under this principal, it is assumed only a portion of the pipe wall resists compressive forces

In order to determine the effective area, AASHTO LRFD design method reduced the actual pipe profile to an idealized profile, both shown in Figure 2-2, in order to simplify the design procedure. The idealized profile is a representation of the actual profile but with straight sides and sharp corners. The thin straight elements that make up the idealized profile are analyzed to determine their effective width and resistance to buckling. Once the effective width of each element is calculated, a reduced effective area is calculated and used to analyze the structural integrity of the pipe section.

**Figure 2-2  
 Typical and Idealized Corrugation Profiles**

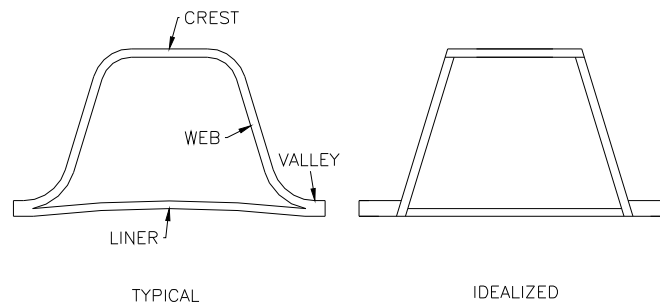

In order to determine the effective width of each element, the idealized profile geometry must be known. This must be determined through meticulous profile measurements to determine the thickness and width of each profile element. The results of such an analysis are provided in ADS Product Notes 2.01 – 2.05.

$$A_{eff} = A_s - \frac{\sum (1 - \rho_i) w_i t_i}{\omega} \quad \text{Equation 2-11}$$

Where:

$A_{eff}$  = effective wall area, in<sup>2</sup>/inch of pipe

$A_s$  = wall area, in<sup>2</sup>/in (Product Note 2.01 – 2.05)

$w_i$  = length of each individual profile element, in (Product Note 2.01 – 2.05)

$t_i$  = thickness of each individual profile element, in (Product Note 2.01 – 2.05)

$\omega$  = profile pitch, in (Product Note 2.01 – 2.05)

$$\rho_i = \frac{1 - \frac{0.22}{\lambda_i}}{\lambda_i} \leq 1 \quad \text{Equation 2-12}$$

Where:

$\rho_i$  = effective width factor

$$\lambda_i = \frac{w_i}{t_i} \sqrt{\frac{\varepsilon}{k}} > 0.673 \quad \text{Equation 2-13}$$

Where:

$\lambda_i$  = slenderness factor

$w_i$  = length of each individual profile element, in (Product Note 2.01 – 2.05)

$t_i$  = thickness of each individual profile element, in (Product Note 2.01 – 2.05)

$k$  = edge support coefficient, 4.0 for elements with both edges supported

$\varepsilon$  = material strain limit, in/in (Table 2-5)

## BUCKLING

The potential for general pipe wall buckling is determined by the burial conditions ( $M_s$ ) and the pipe profile properties ( $A_{eff}$ ,  $I$ ,  $R$ ). The critical buckling stress found from Equation 2-14 must be greater than the actual yield stress ( $F_y$ ). If the critical buckling stress is less than the yield stress, then the compressive resistance to thrust, Equation 2-10, must be recalculated using  $f_{cr}$  in place of  $F_y$ .

### Critical Buckling Stress

$$f_{cr} = 9.24 \frac{R}{A_{eff}} \sqrt{B' R_w \phi_s M_s \frac{EI}{0.149R^3}}$$

Equation 2-14

Where:

- $f_{cr}$  = critical buckling stress, psi
- $M_s$  = secant constrained soil modulus, psi (Table 2-7)
- $R$  = effective radius of pipe, in  
= ID/2+c
- ID = inside diameter of pipe, in (Table 2-1 - 2-4)
- $c$  = distance from inside diameter to neutral axis, in  
(Product Note 2.01 – 2.05)
- $E$  = modulus of elasticity, psi initial and long term (Table 2-5)
- $A_{eff}$  = effective area, in<sup>2</sup>/ft (Equation 2-11)
- $I$  = moment of inertia, in<sup>4</sup>/in (Product Note 2.01 – 2.05)
- $R_w$  = water buoyancy factor  
= 1-0.33h<sub>g</sub>/H
- $H$  = burial depth, ft
- $h_g$  = height of groundwater above crown of pipe, ft
- $\phi_s$  = resistance factor for soil stiffness (Table 2-12)
- $B'$  = nonuniform stress distribution factor

$$= \frac{1}{1 + 4e^{-0.065H}}$$

## COMPRESSIVE STRAIN

An incorrect assumption in calculating actual compressive strain in a pipe wall is to assume all load is applied long-term. Due to the viscoelastic behavior of both polyethylene and polypropylene resins, pipe response under given loading conditions should be analyzed with the material properties most closely representing the loading condition. In this analysis, applied compressive strain ( $\epsilon_{uc}$ ) is determined from Equation 2-15 and then compared to limiting material strain ( $\epsilon$ ), Table 2-5, to ensure material capacity is not exceeded.

### Factored Compressive Strain

$$\epsilon_{uc} = \frac{T_L}{A_{eff} E} = \frac{T_{L-L}}{E_L A_{eff}} + \frac{T_{L-S}}{E_S A_{eff}}$$

Equation 2-15

Where:

- $\epsilon_{uc}$  = factored compressive strain , in/in
- $T_{L-S}$  = factored wall thrust due to short term loading, lb/in
- $T_{L-L}$  = factored wall thrust due to long term loading, lb/in
- $A_{eff}$  = effective wall area, in<sup>2</sup>/inch of pipe (Equation 2-11)

$E_L$  = long term modulus of elasticity, psi (Table 2-5)

$E_S$  = short term modulus of elasticity, psi (Table 2-5)

## BENDING STRAIN

A check on the bending strain will ensure that it is within material capability. In place of a more detailed analysis of bending strain, the strain calculated in this method is based on an empirical relationship between strain and deflection due to loading conditions. In order to account for construction induced deflections, a predetermined limit is introduced into the deflection equation. This results in total deflection due to bending. Once deflection due to bending is determined from Equation 2-16, bending strain can be found with Equation 2-17. The bending strain limit is material specific as shown in Table 2-5.

### Pipe Deflection Due to Bending

$$\Delta = \Delta_c ID - \frac{T_L D_m}{A_{eff} E \gamma_p} = \Delta_c ID - \frac{\varepsilon_{uc} D_m}{\gamma_{EV}} \quad \text{Equation 2-16}$$

Where:

$\Delta$  = deflection of pipe, reduction of vertical diameter due to bending, in

$\Delta_c$  = deflection of pipe, construction induced deflection limit 5%

$\varepsilon_{uc}$  = factored compressive strain, in/in (Equation 2-15)

$\gamma_{EV}$  = load factor, vertical earth pressure, (Table 2-11)

ID = inside diameter of pipe, in (Table 2-1 - 2-4)

$D_m$  = mean pipe diameter, in  
= ID + 2c

c = distance from inside diameter to neutral axis, in  
(Product Note 2.01 – 2.05)

### Factored Bending Strain

$$\varepsilon_{bu} = \gamma_B D_f \left( \frac{c_x}{R} \right) \left( \frac{\Delta}{D_m} \right) \quad \text{Equation 2-17}$$

Where:

$\varepsilon_{bu}$  = factored bending strain, in/in

$D_f$  = shape factor, dimensionless (Table 2-8)

$\Delta$  = deflection, in (Equation 2-16)

$\gamma_B$  = load factor, combined strain, 1.5

R = effective radius of pipe, in  
= ID/2+c

ID = inside diameter of pipe, in (Table 2-1 - 2-4)

$c_x$  = distance from neutral axis to extreme fiber, in (Product Note 2.01 – 2.05)

$D_m$  = mean pipe diameter, in  
= ID + 2c

## COMBINED STRAIN

If it is determined bending strain is within the allowable limit, the combined strain due to bending and thrust must be checked to make sure they do not exceed the factored strain limits. These shall be checked for both compression and tension conditions. The factored combined compressive strain determined from Equation 2-18 shall not exceed the limiting combined compressive strain determined from Equation 2-19. Additionally, the factored combined tension strain determined from Equation 2-20 shall not exceed the limiting combined tension strain determined from Equation 2-21.

### Factored Combined Compressive Strain

$$\epsilon_{cu} = \epsilon_{bu} + \epsilon_{uc} \frac{\gamma_B}{\gamma_P} \quad \text{Equation 2-18}$$

Where:

$\epsilon_{cu}$  = factored compressive strain, in/in

$\epsilon_{bu}$  = factored bending strain, in/in (Equation 2-17)

$\epsilon_{uc}$  = factored compressive strain, in/in (Equation 2-15)

$\gamma_P$  = load factor, vertical earth pressure (Table 2-11)

$\gamma_B$  = load factor, combined strain, 1.5

### Limiting Combined Compressive Strain

$$\epsilon_{cl} = \left( \frac{1.5F_y}{E_{50}} \right) \quad \text{Equation 2-19}$$

Where:

$\epsilon_{cl}$  = limiting combined compressive strain, in/in

$F_y$  = Long term tensile strength, psi (Table 2-5)

$E_{50}$  = long term modulus of elasticity, psi (Table 2-5)

### Factored Combined Tension Strain

$$\epsilon_{tu} = \epsilon_{bu} - \epsilon_{uc} \frac{\gamma_B}{\gamma_P} \quad \text{Equation 2-20}$$

Where:

$\epsilon_{tu}$  = factored tension strain, in/in

$\epsilon_{bu}$  = factored bending strain, in/in (Equation 2-17)

$\epsilon_{uc}$  = factored compressive strain, in/in (Equation 2-15)



$\gamma_p$  = load factor, vertical earth pressure (Table 2-11)

$\gamma_B$  = load factor, combined strain, 1.5

### Limiting Combined Tension Strain

$$\varepsilon_{tl} = \gamma_B \varepsilon_t$$

Equation 2-21

Where:

$\varepsilon_{tl}$  = limiting combined tension strain, in/in

$\gamma_B$  = load factor, combined strain, 1.5

$\varepsilon_t$  = allowable tension strain, in/in (Table 2-5)

## 2-5 RESEARCH AND INSTALLATIONS

Corrugated polyethylene pipe has been heavily researched in the laboratory and through actual installations. This section summarizes the findings of some of those projects; additional information about these and other reports can be obtained from ADS.

**“Analysis of the Performance of a Buried High Density Polyethylene Pipe.”** Written by Naila Hashash and Ernest Selig, University of Massachusetts, and published in *Structural Performance of Flexible Pipes*, edited by Sargand, Mitchell, and Hurd, October 1990, pp. 95 - 103.

In 1988, the Pennsylvania Department of Transportation began a study to evaluate the behavior of polyethylene pipe similar to ADS AASHTO pipe backfilled with crushed stone under a 100 foot (30.5m) burial depth. This document, which is a status report of the pipe condition 722 days after installation, summarizes one of the most heavily instrumented pipe installations to date. Measured vertical deflection was 4.6% and horizontal deflection was 0.6%. Much of this was due to a slight (1.6%) circumferential shortening. This amount of deflection is well within the 7.5% generally accepted limit. Soil arching reduced the load on the pipe by 77% which shows that the soil column load is a very conservative method to estimate this load component.

**“Field Performance of Corrugated Polyethylene Pipe.”** Written by John Hurd, Ohio Department of Transportation, and published in *Public Works*, October 1987.

This article summarizes the results of a field study conducted in 1985 on 172 culvert installations. These installations represented real-world applications where backfill procedures may or may not have been conducted in accordance with standard ODOT recommendations. Regardless, the primary findings regarding structural integrity were that shallow cover, even with heavy truck traffic, did not appear to cause significant amounts of deflection; what deflection that did occur seemed to be due to installation.

**“Laboratory Test of Buried Pipe in Hoop Compression.”** Written by Ernest Selig, Leonard DiFrancesco, and Timothy McGrath, and published in *Buried Plastic Pipe Technology - 2nd Volume*, 1994, pp. 119 - 132.

The project involved developing a fixture so as to subject the pipe to purely compressive forces. A pressure of 55 psi (379 kPa) was reached at which time equipment problems developed. The authors indicated this pressure was the equivalent of 100 feet (30.5m) of cover in other tests they had performed. At this pressure, the pipe also experienced a 3% circumferential shortening which resulted in a significant beneficial soil arching.

**“Pipe Deflections - A Redeemable Asset.”** Written by Dr. Lester Gabriel and published in *Structural Performance of Flexible Pipes*, edited by Sargand, Mitchell, and Hurd, October 1990, pp. 1 - 6.

This paper provides an easy-to-read description of the role of deflection in properly performing flexible pipe. Deflection is not a liability, but a behavior

that forces the backfill material to take on a disproportionate amount of load. Deflection allows flexible pipe to be installed in applications with surprisingly deep burials.

**“Short-term Versus Long-term Pipe Ring Stiffness in the Design of Buried Plastic Sewer Pipes.”** Written by Lars-Eric Janson and published in *Pipeline Design and Installation*, proceedings from the International Conference sponsored by the Pipeline Planning Committee of the Pipeline Division of the American Society of Civil Engineers, March 1990, pp. 160 - 167.

This report describes the viscoelastic behavior of polyethylene. The author suggests use of short-term properties when the pipe is backfilled in friction soils or firm silty/clayey soils.

**“Stress Relaxation Characteristics of the HDPE Pipe-Soil System.”** Written by Larry Petroff and published in *Pipeline Design and Installation*, proceedings from the International Conference sponsored by the Pipeline Planning Committee of the Pipeline Division of the American Society of Civil Engineers, March 1990, pp. 280-293.

This is an excellent report on the viscoelastic nature of polyethylene and discusses both creep and stress relaxation behaviors. One of the major points made is how deflection decreases with time; over 80% of the total deflection that a pipe will experience throughout its life will occur within the first 30 days. Petroff also indicated that the highest stresses for polyethylene pipe buried in a compacted granular material occur soon after installation but relax soon thereafter.

**“Stiffness of HDPE Pipe in Ring Bending.”** Written by Timothy McGrath, Ernest Selig, and Leonard DiFrancesco, and published in *Buried Plastic Pipe Technology- 2nd Volume*, 1994, pp. 195 - 205.

This project was conducted to determine how or if the modulus of elasticity changes over time. The pipe was deflected and held in position to generate a stress/strain curve. Although the results gave the appearance that the material was losing strength over time, repeated incremental loads caused the pipe to respond with its short-term modulus.

**“Structural Performance of Three-Foot Corrugated Polyethylene Pipe Buried Under High Soil Cover.”** Written by Reynold Watkins and published in *Structural Performance of Flexible Pipes*, edited by Sargand, Mitchell, and Hurd, October 1990, pp. 105 - 107.

A three-foot (900mm) diameter corrugated polyethylene pipe was tested in a load cell to determine if it performed as well as the smaller sizes. The author recognizes the effects of stress relaxation. The report concludes “There is no reason why corrugated polyethylene pipes of three-foot diameter cannot perform structurally under high soil cover provided that a good granular pipe zone backfill is carefully placed and compacted.” This is consistent with the backfill and material recommendations set forth in previous sections.