

Water Management Drainage Handbook



Specifications



1-0 SPECIFICATIONS

TABLE OF CONTENTS

N-12 [®] ST IB Pipe (ASTM F2648) Specification	3
N-12 WT IB Pipe (per ASTM F2648) Specification.....	4
N-12 ST IB Pipe (per AASHTO) Specification.....	5
N-12 WT IB Pipe (per AASHTO) Specification.....	6
N-12 Mega Green [™] ST IB Pipe Specification	7
N-12 Mega Green WT IB Pipe Specification	8
N-12 WT Series 35 Pipe Specification	9
N-12 Plain End Pipe (per ASTM F2648) Specification	10
N-12 Plain End Pipe (per AASHTO) Specification.....	11
N-12 Mega Green Plain End Pipe Specification	12
Landmax Retention/Detention Pipe System Specifiaction	13
HP Storm 12”- 60” Pipe Specification	15
SaniTite [®] HP 12”- 60” Pipe Specification	16
N-12 Low Head Pipe Specification	17
Single Wall Pipe Specification	19
Single Wall Heavy Duty Pipe Specification	21
Grain-Aire [®] Pipe Specification.....	22
AdvanEdge [®] Pipe Specification.....	23
SB2 [®] Pipe Specification	24
ADS 3000 TripleWall [®] Pipe Specification	25
Smoothwall Sewer & Drain Pipe Specification	26
Channel-Flow [®] Pipe Specification.....	27
Channel Muck Pipe Specification.....	28
Duraslot [®] Pipe Specification.....	29
Duraslot XL Pipe Specification	31
Injection Molded Fitting Specification	33
Mar Mac [®] Polyseal Repair Coupler Specification	35
PVC Coupling Specification.....	36
Waterstop [™] Gasket Specification	37
Flared End Section Specification	38
Mitered End Section Specification	39
Taylor End Plug Specification	40
Storm Water Quality Unit Specification	41
Biodiffuser [™] Septic Leaching Chamber Specification	43

Arc™ Septic Leaching Chamber Specification 44
Sump Pump Well Specification 45
Radon Dual Purpose Vented Sump Specification 46
Sewage Ejector Sump Specification 47
Filter Sock Specification 48

N-12® ST IB PIPE (ASTM F2648) SPECIFICATION

Scope

This specification describes 4- through 30-inch (100 to 750 mm) N-12 ST IB pipe (per ASTM F2648) for use in gravity-flow land drainage applications.

Pipe Requirements

N-12 ST IB pipe (per ASTM F2648) shall have a smooth interior and annular exterior corrugations.

- 4- through 30-inch (100 to 750 mm) pipe shall meet ASTM F2648.
- Manning’s “n” value for use in design shall be 0.012.

Joint Performance

Pipe shall be joined using a bell & spigot joint meeting ASTM F2648. The joint shall be soil-tight and gaskets for diameters 12- through 30-inch (300-750 mm), shall meet the requirements of ASTM F477. For diameters 4- through 10-inch, the joint shall be soil-tight using an engaging dimple connection. Gaskets shall be installed by the pipe manufacturer and covered with a removable, protective wrap to ensure the gasket is free from debris. A joint lubricant available from the manufacturer shall be used on the gasket and bell during assembly.

Fittings

Fittings shall conform to ASTM F2306. Bell and spigot connections shall utilize a welded bell and valley or saddle gasket meeting the soil-tight joint performance requirements of ASTM F2306.

Material Properties

Material for pipe production shall be an engineered compound of virgin and recycled high density polyethylene conforming with the minimum requirements of cell classification 424420C (ESCR Test Condition B) for 4- through 10-inch (100 to 250 mm) diameters, and 435420C (ESCR Test Condition B) for 12- through 30-inch (300 to 750 mm) diameters, as defined and described in the latest version of ASTM D3350, except that carbon black content should not exceed 4%. The design engineer shall verify compatibility with overall system including structural, hydraulic, material, and installation requirements for a given application.

Installation

Installation shall be in accordance with ASTM D2321 and ADS recommended installation guidelines, with the exception that minimum cover in trafficked areas for 4- through 30-inch (100 to 750 mm) diameters shall be one foot (0.3 m) in single run applications. Backfill for minimum cover situations shall consist of Class 1 (compacted) or Class 2 (minimum 90% SPD) material. Maximum fill heights depend on embedment material and compaction level; please refer to Technical Note 2.02. Contact your local ADS representative or visit our website at www.adspipe.com for a copy of the latest installation guidelines.

Pipe Dimensions

Pipe I.D. in (mm)	4 (100)	6 (150)	8 (200)	10 (250)	12 (300)	15 (375)	18 (450)	24 (600)	30 (750)
Pipe O.D.* in (mm)	4.8 (122)	6.9 (175)	9.1 (231)	11.4 (290)	14.5 (368)	18 (457)	22 (559)	28 (711)	36 (914)

*Pipe O.D. values are provided for reference purposes only, values stated for 12 through 30-inch are ±1 inch.

Contact a sales representative for exact values

**All diameters available with or without perforations.

N-12® WT IB PIPE (PER ASTM F2648) SPECIFICATION

Scope

This specification describes 4- through 60-inch (100 to 1500 mm) N-12 WT IB pipe (per ASTM F2648) for use in gravity-flow land drainage applications.

Pipe Requirements

N-12 WT IB pipe (per ASTM F2648) shall have a smooth interior and annular exterior corrugations.

- 4- through 60-inch (100 to 1500 mm) pipe shall meet ASTM F2648.
- Manning’s “n” value for use in design shall be 0.012.

Joint Performance

Pipe shall be joined using a bell & spigot joint meeting ASTM F2648. The joint shall be watertight according to the requirements of ASTM D3212. Gaskets shall meet the requirements of ASTM F477. Gaskets shall be installed by the pipe manufacturer and covered with a removable, protective wrap to ensure the gasket is free from debris. A joint lubricant available from the manufacturer shall be used on the gasket and bell during assembly. 12- through 60-inch (300 to 1500 mm) diameters shall have an exterior bell wrap installed by the manufacturer.

Fittings

Fittings shall conform to ASTM F2306. Bell and spigot connections shall utilize a welded bell and valley or saddle gasket meeting the watertight joint performance requirements of ASTM F2306.

Field Pipe and Joint Performance

To assure watertightness, field performance verification may be accomplished by testing in accordance with ASTM F2487. Appropriate safety precautions must be used when field-testing any pipe material. Contact the manufacturer for recommended leakage rates.

Material Properties

Material for pipe production shall be an engineered compound of virgin and recycled high-density polyethylene conforming with the minimum requirements of cell classification 424420C (ESCR Test Condition B) for 4- through 10-inch (100 to 250 mm) diameters, and 435420C (ESCR Test Condition B) for 12- through 60-inch (300 to 1500 mm) diameters, as defined and described in the latest version of ASTM D3350, except that carbon black content should not exceed 4%. The design engineer shall verify compatibility with overall system including structural, hydraulic, material, and installation requirements for a given application.

Installation

Installation shall be in accordance with ASTM D2321 and ADS recommended installation guidelines, with the exception that minimum cover in trafficked areas for 4- through 48-inch (100 to 1200 mm) diameters shall be one foot (0.3 m) and for 60-inch (1500 mm) diameter the minimum cover shall be 2 ft. (0.6 m) in single run applications. Backfill for minimum cover situations shall consist of Class 1 (compacted) or Class 2 (minimum 90% SPD) material. Maximum fill heights depend on embedment material and compaction level; please refer to Technical Note 2.02. Contact your local ADS representative or visit our website at www.adspipe.com for a copy of the latest installation guidelines.

Pipe Dimensions

Pipe I.D. in (mm)	4 (100)	6 (150)	8 (200)	10 (250)	12 (300)	15 (375)	18 (450)	24 (600)	30 (750)	36 (900)	42 (1050)	48 (1200)	60 (1500)
Pipe O.D.* in (mm)	4.8 (122)	6.9 (175)	9.1 (231)	11.4 (290)	14.5 (368)	18 (457)	22 (559)	28 (711)	36 (914)	42 (1067)	48 (1219)	54 (1372)	67 (1702)

*Pipe O.D. values are provided for reference purposes only, values stated for 12 through 60-inch are ±1 inch. Contact a sales representative for exact values

N-12[®] ST IB PIPE (PER AASHTO) SPECIFICATION

Scope

This specification describes 4- through 30-inch (100 to 750 mm) N-12 ST IB pipe (per AASHTO) for use in gravity-flow land drainage applications.

Pipe Requirements

N-12 ST IB pipe (per AASHTO) shall have a smooth interior and annular exterior corrugations.

- 4- through 10-inch (100 to 250 mm) pipe shall meet AASHTO M252, Type S or SP.
- 12- through 30-inch (300 to 750 mm) pipe shall meet AASHTO M294, Type S or SP, or ASTM F2306.
- Manning's "n" value for use in design shall be 0.012.

Joint Performance

Pipe shall be joined using a bell & spigot joint meeting the requirements of AASHTO M252, AASHTO M294, or ASTM F2306. The joint shall be soil-tight and gaskets for diameters 12- through 30-inch (300-750 mm), shall meet the requirements of ASTM F477. For diameters 4- through 10-inch, the joint shall be soil-tight using an engaging dimple connection. Gaskets shall be installed by the pipe manufacturer and covered with a removable, protective wrap to ensure the gasket is free from debris. A joint lubricant available from the manufacturer shall be used on the gasket and bell during assembly.

Fittings

Fittings shall conform to AASHTO M252, AASHTO M294, or ASTM F2306. Bell and spigot connections shall utilize a welded bell and valley or saddle gasket meeting the soil-tight joint performance requirements of AASHTO M252, AASHTO M294, or ASTM F2306.

Material Properties

Material for pipe and fitting production shall be high density polyethylene conforming with the minimum requirements of cell classification 424420C for 4- through 10-inch (100 to 250 mm) diameters, and 435400C for 12- through 30-inch (300 to 750 mm) diameters, as defined and described in the latest version of ASTM D3350, except that carbon black content should not exceed 4%. The 12- through 30-inch (300 to 750 mm) pipe material shall comply with the notched constant ligament-stress (NCLS) test as specified in Sections 9.5 and 5.1 of AASHTO M294 and ASTM F2306, respectively.

Installation

Installation shall be in accordance with ASTM D2321 and ADS recommended installation guidelines, with the exception that minimum cover in trafficked areas for 4- through 30-inch (100 to 750 mm) diameters shall be one foot (0.3 m) in single run applications. Backfill for minimum cover situations shall consist of Class 1 (compacted), Class 2 (minimum 90% SPD) or Class 3 (minimum 95% SPD) material. Maximum fill heights depend on embedment material and compaction level; please refer to Technical Note 2.01. Contact your local ADS representative or visit our website at www.adspipe.com for a copy of the latest installation guidelines.

Build America, Buy America (BABA)

N-12 ST IB pipe (per AASHTO), manufactured in accordance with AASHTO M252, AASHTO M294 or ASTM F2306, complies with the requirements in the Build America, Buy America (BABA) Act.

Pipe Dimensions

Pipe I.D. in (mm)	4 (100)	6 (150)	8 (200)	10 (250)	12 (300)	15 (375)	18 (450)	24 (600)	30 (750)
Pipe O.D.* in (mm)	4.8 (122)	6.9 (175)	9.1 (231)	11.4 (290)	14.5 (368)	18 (457)	22 (559)	28 (711)	36 (914)

*Pipe O.D. values are provided for reference purposes only, values stated for 12 through 30-inch are ± 1 inch.

Contact a sales representative for exact values

**All diameters available with or without perforations.

N-12® WT IB PIPE (PER AASHTO) SPECIFICATION

Scope

This specification describes 4- through 60-inch (100 to 1500 mm) N-12 WT IB pipe (per AASHTO) for use in gravity-flow land drainage applications.

Pipe Requirements

N-12 WT IB pipe (per AASHTO) shall have a smooth interior and annular exterior corrugations.

- 4- through 10-inch (100 to 250 mm) pipe shall meet AASHTO M252, Type S.
- 12- through 60-inch (300 to 1500 mm) pipe shall meet AASHTO M294, Type S or ASTM F2306.
- Manning’s “n” value for use in design shall be 0.012.

Joint Performance

Pipe shall be joined using a bell & spigot joint meeting the requirements of AASHTO M252, AASHTO M294, or ASTM F2306. The joint shall be watertight according to the requirements of ASTM D3212. Gaskets shall meet the requirements of ASTM F477. Gaskets shall be installed by the pipe manufacturer and covered with a removable, protective wrap to ensure the gasket is free from debris. A joint lubricant available from the manufacturer shall be used on the gasket and bell during assembly. 12- through 60-inch (300 to 1500 mm) diameters shall have an exterior bell wrap installed by the manufacturer.

Fittings

Fittings shall conform to AASHTO M252, AASHTO M294, or ASTM F2306. Bell and spigot connections shall utilize a welded bell and valley or saddle gasket meeting the watertight joint performance requirements of AASHTO M252, AASHTO M294, or ASTM F2306.

Field Pipe and Joint Performance

To assure watertightness, field performance verification may be accomplished by testing in accordance with ASTM F2487. Appropriate safety precautions must be used when field-testing any pipe material. Contact the manufacturer for recommended leakage rates.

Material Properties

Material for pipe and fitting production shall be high-density polyethylene conforming with the minimum requirements of cell classification 424420C for 4- through 10-inch (100 to 250 mm) diameters, and 435400C for 12- through 60-inch (300 to 1500 mm) diameters, as defined and described in the latest version of ASTM D3350, except that carbon black content should not exceed 4%. The 12- through 60-inch (300 to 1500 mm) pipe material shall comply with the notched constant ligament-stress (NCLS) test as specified in Sections 9.5 and 5.1 of AASHTO M294 and ASTM F2306 respectively.

Installation

Installation shall be in accordance with ASTM D2321 and ADS recommended installation guidelines, with the exception that minimum cover in trafficked areas for 4- through 48-inch (100 to 1200 mm) diameters shall be one foot. (0.3 m) and for 60-inch (1500 mm) diameter the minimum cover shall be 2 ft. (0.6 m) in single run applications. Backfill for minimum cover situations shall consist of Class 1 (compacted), Class 2 (minimum 90% SPD) or Class 3 (minimum 95%) material. Maximum fill heights depend on embedment material and compaction level; please refer to Technical Note 2.01. Contact your local ADS representative or visit our website at www.adspipe.com for a copy of the latest installation guidelines.

Build America, Buy America (BABA)

N-12 WT IB pipe (per AASHTO), manufactured in accordance with AASHTO M252, AASHTO M294 or ASTM F2306, complies with the requirements in the Build America, Buy America (BABA) Act.

Pipe Dimensions

Pipe I.D. in (mm)	4 (100)	6 (150)	8 (200)	10 (250)	12 (300)	15 (375)	18 (450)	24 (600)	30 (750)	36 (900)	42 (1050)	48 (1200)	60 (1500)
Pipe O.D.* in (mm)	4.8 (122)	6.9 (175)	9.1 (231)	11.4 (290)	14.5 (368)	18 (457)	22 (559)	28 (711)	36 (914)	42 (1067)	48 (1219)	54 (1372)	67 (1702)

*Pipe O.D. values are provided for reference purposes only, values stated for 12 through 60-inch are ±1 inch. Contact a sales representative for exact values

N-12[®] MEGA GREEN[™] ST IB PIPE SPECIFICATION

Scope

This specification describes 4- through 30-inch (100 to 750 mm) N-12 MEGA GREEN[™] ST IB pipe for use in gravity-flow land drainage applications.

Pipe Requirements

N-12 MEGA GREEN ST IB pipe shall have a smooth interior and annular exterior corrugations.

- 4- through 30-inch (100 to 750 mm) pipe shall meet ASTM F2648.
- Manning’s “n” value for use in design shall be 0.012.

Joint Performance

Pipe shall be joined using a bell & spigot joint meeting ASTM F2648. The joint shall be soil-tight and gaskets for diameters 12- through 30-inch (300-750 mm), shall meet the requirements of ASTM F477. For diameters 4- through 10-inch, the joint shall be soil-tight using an engaging dimple connection. Gaskets shall be installed by the pipe manufacturer and covered with a removable, protective wrap to ensure the gasket is free from debris. A joint lubricant available from the manufacturer shall be used on the gasket and bell during assembly.

Fittings

Fittings shall conform to ASTM F2306. Bell and spigot connections shall utilize a welded bell and valley or saddle gasket meeting the soil-tight joint performance requirements of ASTM F2306.

Material Properties

Material for pipe production shall be an engineered compound of virgin and recycled high density polyethylene conforming with the minimum requirements of cell classification 424420C (ESCR Test Condition B) for 4- through 10-inch (100 to 250 mm) diameters, and 435420C (ESCR Test Condition B) for 12- through 30-inch (300 to 750 mm) diameters, as defined and described in the latest version of ASTM D3350, except that carbon black content should not exceed 4%. The design engineer shall verify compatibility with overall system including structural, hydraulic, material, and installation requirements for a given application.

Installation

Installation shall be in accordance with ASTM D2321 and ADS recommended installation guidelines, with the exception that minimum cover in trafficked areas for 4- through 48-inch (100 to 1200 mm) diameters shall be one foot (0.3 m) in single run applications. Backfill for minimum cover situations shall consist of Class 1 (compacted) or Class 2 (minimum 90% SPD) material. Maximum fill heights depend on embedment material and compaction level; please refer to Technical Note 2.02. Contact your local ADS representative or visit our website at www.adspipe.com for a copy of the latest installation guidelines.

Pipe Dimensions

Pipe I.D. in (mm)	4 (100)	6 (150)	8 (200)	10 (250)	12 (300)	15 (375)	18 (450)	24 (600)	30 (750)
Pipe O.D.* in (mm)	4.8 (122)	6.9 (175)	9.1 (231)	11.4 (290)	14.5 (368)	18 (457)	22 (559)	28 (711)	36 (914)

*Pipe O.D. values are provided for reference purposes only, values stated for 12 through 30-inch are ±1 inch.

Contact a sales representative for exact values

**All diameters available with or without perforations.

N-12[®] MEGA GREEN[™] WT IB PIPE SPECIFICATION

Scope

This specification describes 4- through 60-inch (100 to 1500 mm) N-12 MEGA GREEN[™] WT IB pipe for use in gravity-flow land drainage applications.

Pipe Requirements

N-12 MEGA GREEN WT IB pipe shall have a smooth interior and annular exterior corrugations.

- 4- through 60-inch (100 to 1500 mm) pipe shall meet ASTM F2648.
- Manning’s “n” value for use in design shall be 0.012.

Joint Performance

Pipe shall be joined using a bell & spigot joint meeting ASTM F2648. The joint shall be watertight according to the requirements of ASTM D3212. Gaskets shall meet the requirements of ASTM F477. Gaskets shall be installed by the pipe manufacturer and covered with a removable, protective wrap to ensure the gasket is free from debris. A joint lubricant available from the manufacturer shall be used on the gasket and bell during assembly. 12- through 60-inch (300 to 1500 mm) diameters shall have an exterior bell wrap installed by the manufacturer.

Fittings

Fittings shall conform to ASTM F2306. Bell and spigot connections shall utilize a welded bell and valley or saddle gasket meeting the watertight joint performance requirements of ASTM F2306.

Field Pipe and Joint Performance

To assure watertightness, field performance verification may be accomplished by testing in accordance with ASTM F2487. Appropriate safety precautions must be used when field-testing any pipe material. Contact the manufacturer for recommended leakage rates.

Material Properties

Material for pipe production shall be an engineered compound of virgin and recycled high density polyethylene conforming with the minimum requirements of cell classification 424420C (ESCR Test Condition B) for 4- through 10-inch (100 to 250 mm) diameters, and 435420C (ESCR Test Condition B) for 12- through 60-inch (300 to 1500 mm) diameters, as defined and described in the latest version of ASTM D3350, except that carbon black content should not exceed 4%. The design engineer shall verify compatibility with overall system including structural, hydraulic, material, and installation requirements for a given application.

Installation

Installation shall be in accordance with ASTM D2321 and ADS recommended installation guidelines, with the exception that minimum cover in trafficked areas for 4- through 48-inch (100 to 1200 mm) diameters shall be one foot. (0.3 m) and for 60-inch (1500 mm) diameter the minimum cover shall be 2 ft. (0.6 m) in single run applications. Backfill for minimum cover situations shall consist of Class 1 (compacted) or Class 2 (minimum 90% SPD) material. Maximum fill heights depend on embedment material and compaction level; please refer to Technical Note 2.02. Contact your local ADS representative or visit our website at www.adspipe.com for a copy of the latest installation guidelines.

Pipe Dimensions

Pipe I.D. in (mm)	4 (100)	6 (150)	8 (200)	10 (250)	12 (300)	15 (375)	18 (450)	24 (600)	30 (750)	36 (900)	42 (1050)	48 (1200)	60 (1500)
Pipe O.D.* in (mm)	4.8 (122)	6.9 (175)	9.1 (231)	11.4 (290)	14.5 (368)	18 (457)	22 (559)	28 (711)	36 (914)	42 (1067)	48 (1219)	54 (1372)	67 (1702)

*Pipe O.D. values are provided for reference purposes only, values stated for 12 through 60-inch are ±1 inch. Contact a sales representative for exact values

N-12® WT SERIES 35 PIPE SPECIFICATION

Scope

This specification describes 4- through 24-inch (100 to 600 mm) N-12 WT Series 35 pipe for use in gravity-flow land drainage applications.

Pipe Requirements

N-12 WT Series 35 pipe shall have a smooth interior and annular exterior corrugations.

- 4- through 10-inch (100 to 250 mm) pipe shall meet AASHTO M252, Type S.
- 12- through 24-inch (300 to 600 mm) pipe shall meet AASHTO M294, Type S or ASTM F2306.
- Manning’s “n” value for use in design shall be 0.012.

Joint Performance

Pipe shall be joined with the N-12 WT Series 35 joint meeting the requirements of AASHTO M252, AASHTO M294 or ASTM F2306. The joint shall be watertight according to the requirements of ASTM D3212. Gaskets shall meet the requirements of ASTM F477. Gaskets shall be installed by the pipe manufacturer and covered with a removable, protective wrap to ensure the gasket is free from debris. A joint lubricant available from the manufacturer shall be used on the gasket and bell during assembly.

Bells shall be bell-bell couplers manufactured from PVC. Bell-bell couplers shall be installed on one side by the manufacturer.

Fittings

Fittings shall conform to AASHTO M252, AASHTO M294, or ASTM F2306. Joint connections shall utilize a PVC bell-bell coupler and valley gasket meeting the watertight joint performance requirements of AASHTO M252, AASHTO M294, or ASTM F2306.

Material Properties

Material for pipe and fitting production shall be high-density polyethylene conforming with the minimum requirements of cell classification 424420C for 4- through 10-inch (100 to 250 mm) diameters, and 435400C for 12- through 24-inch (300 to 600 mm) diameters, as defined and described in the latest version of ASTM D3350, except that carbon black content should not exceed 4%. The 12- through 24-inch (300 to 600 mm) pipe material shall comply with the notched constant ligament-stress (NCLS) test as specified in Sections 9.5 and 5.1 of AASHTO M294 and ASTM F2306 respectively.

Bells shall be manufactured from PVC pipe stock, utilizing a thermo-molding process to reform the pipe stock to the specified coupler. The pipe stock used to manufacture the bell-bell coupler shall meet the performance requirements for fabricated fittings as specified in ASTM D3034.

Installation

Installation shall be in accordance with ASTM D2321 and ADS recommended installation guidelines, with the exception that minimum cover in trafficked areas for 4- through 24-inch (100 to 600 mm) diameters shall be one foot (0.3 m) in single run applications. Backfill for minimum cover situations shall consist of Class 1 (compacted), Class 2 (minimum 90% SPD), or Class 3 (minimum 95%) material. Maximum fill heights depend on embedment material and compaction level; please refer to Technical Note 2.01. Contact your local ADS representative or visit our website at www.adspipe.com for a copy of the latest installation guidelines.

Build America, Buy America (BABA)

N-12 WT Series 35 pipe, manufactured in accordance with AASHTO M252, AASHTO M294 or ASTM F2306, complies with the requirements in the Build America, Buy America (BABA) Act.

Pipe Dimensions

Pipe I.D. in (mm)	4 (100)	6 (150)	8 (200)	10 (250)	12 (300)	15 (375)	18 (450)	24 (600)
Pipe O.D.* in (mm)	4.8 (122)	6.9 (175)	9.1 (231)	11.4 (290)	14.5 (368)	18 (457)	22 (559)	28 (711)

*Pipe O.D. values are provided for reference purposes only, values stated for 12 through 60-inch are ±1 inch. Contact a sales representative for exact values

N-12® PLAIN END PIPE (PER ASTM F2648) SPECIFICATION

Scope

This specification describes 4- through 60-inch (100 to 1500 mm) N-12 plain end pipe (per ASTM F2648) for use in gravity-flow land drainage applications.

Pipe Requirements

N-12 plain end pipe (per ASTM F2648) shall have a smooth interior and annular exterior corrugations.

- 4- through 60-inch (100 to 1500 mm) pipe shall meet ASTM F2648.
- Manning’s “n” value for use in design shall be 0.012.

Joint Performance

Pipe shall be joined with coupling bands covering at least two full corrugations on each end of the pipe. Standard connections shall meet or exceed the soil-tight requirements of ASTM F2648.

Gasketed connections shall incorporate a closed-cell synthetic expanded rubber gasket meeting the requirements of ASTM D1056 Grade 2A2. Gaskets, when applicable, shall be installed by the pipe manufacturer.

Fittings

Fittings shall conform to ASTM F2306.

Material Properties

Material for pipe production shall be an engineered compound of virgin and recycled high density polyethylene conforming with the minimum requirements of cell classification 424420C (ESCR Test Condition B) for 4- through 10-inch (100 to 250 mm) diameters, and 435420C (ESCR Test Condition B) for 12- through 60-inch (300 to 1500 mm) diameters, as defined and described in the latest version of ASTM D3350, except that carbon black content should not exceed 4%. The design engineer shall verify compatibility with overall system including structural, hydraulic, material, and installation requirements for a given application.

Installation

Installation shall be in accordance with ASTM D2321 and ADS recommended installation guidelines, with the exception that minimum cover in trafficked areas for 4- through 48-inch (100 to 1200 mm) diameters shall be one foot (0.3 m) and for 60-inch (1500 mm) diameter the minimum cover shall be 2 ft. (0.6 m) in single run applications. Backfill for minimum cover situations shall consist of Class 1 (compacted) or Class 2 (minimum 90% SPD) material. Maximum fill heights depend on embedment material and compaction level; please refer to Technical Note 2.02. Contact your local ADS representative or visit our website at www.adspipe.com for a copy of the latest installation guidelines.

Pipe Dimensions

Pipe I.D. in (mm)	4 (100)	6 (150)	8 (200)	10 (250)	12 (300)	15 (375)	18 (450)	24 (600)	30 (750)	36 (900)	42 (1050)	48 (1200)	60 (1500)
Pipe O.D.* in (mm)	4.8 (122)	6.9 (175)	9.1 (231)	11.4 (290)	14.5 (368)	18 (457)	22 (559)	28 (711)	36 (914)	42 (1067)	48 (1219)	54 (1372)	67 (1702)

*Pipe O.D. values are provided for reference purposes only, values stated for 12 through 60-inch are ±1 inch. Contact a sales representative for exact values

**All diameters available with or without perforations.

N-12® PLAIN END PIPE (PER AASHTO) SPECIFICATION

Scope

This specification describes 4- through 60-inch (100 to 1500 mm) N-12 plain end pipe (per AASHTO) for use in gravity-flow land drainage applications.

Pipe Requirements

N-12 plain end pipe (per AASHTO) shall have a smooth interior and annular exterior corrugations.

- 4- through 10-inch (100 to 250 mm) pipe shall meet AASHTO M252, Type S or SP.
- 12- through 60-inch (300 to 1500 mm) pipe shall meet AASHTO M294, Type S or SP, or ASTM F2306.
- Manning’s “n” value for use in design shall be 0.012.

Joint Performance

Pipe shall be joined with coupling bands covering at least two full corrugations on each end of the pipe. Standard connections shall meet or exceed the soil-tight requirements of AASHTO M252, AASHTO M294, or ASTM F2306.

Gasketed connections shall incorporate a closed-cell synthetic expanded rubber gasket meeting the requirements of ASTM D1056 Grade 2A2. Gaskets, when applicable, shall be installed by the pipe manufacturer.

Fittings

Fittings shall conform to AASHTO M252, AASHTO M294, or ASTM F2306.

Material Properties

Material for pipe and fitting production shall be high density polyethylene conforming with the minimum requirements of cell classification 424420C for 4- through 10-inch (100 to 250 mm) diameters, and 435400C for 12- through 60-inch (300 to 1500 mm) diameters, as defined and described in the latest version of ASTM D3350, except that carbon black content should not exceed 4%. The 12- through 60-inch (300 to 1500mm) pipe material shall comply with the notched constant ligament-stress (NCLS) test as specified in Sections 9.5 and 5.1 of AASHTO M294 and ASTM F2306 respectively.

Installation

Installation shall be in accordance with ASTM D2321 and ADS recommended installation guidelines, with the exception that minimum cover in trafficked areas for 4- through 48-inch (100 to 1200 mm) diameters shall be one foot. (0.3 m) and for 60-inch (1500 mm) diameter the minimum cover shall be 2 ft. (0.6 m) in single run applications. Backfill for minimum cover situations shall consist of Class 1 (compacted), Class 2 (minimum 90% SPD) or Class 3 (minimum 95%) material. Maximum fill heights depend on embedment material and compaction level; please refer to Technical Note 2.01. Contact your local ADS representative or visit our website at www.adspipe.com for a copy of the latest installation guidelines.

Build America, Buy America (BABA)

N-12 Plain End pipe (per AASHTO), manufactured in accordance with AASHTO M252, AASHTO M294 or ASTM F2306, complies with the requirements in the Build America, Buy America (BABA) Act.

Pipe Dimensions

Pipe I.D. in (mm)	4 (100)	6 (150)	8 (200)	10 (250)	12 (300)	15 (375)	18 (450)	24 (600)	30 (750)	36 (900)	42 (1050)	48 (1200)	60 (1500)
Pipe O.D.* in (mm)	4.8 (122)	6.9 (175)	9.1 (231)	11.4 (290)	14.5 (368)	18 (457)	22 (559)	28 (711)	36 (914)	42 (1067)	48 (1219)	54 (1372)	67 (1702)

*Pipe O.D. values are provided for reference purposes only, values stated for 12 through 60-inch are ±1 inch. Contact a sales representative for exact values

**All diameters available with or without perforations.

N-12® MEGA GREEN PLAIN END PIPE SPECIFICATION

Scope

This specification describes 4- through 60-inch (100 to 1500 mm) N-12 MEGA GREEN™ plain end pipe for use in gravity-flow land drainage applications.

Pipe Requirements

N-12 MEGA GREEN plain end pipe shall have a smooth interior and annular exterior corrugations.

- 4- through 60-inch (100 to 1500 mm) pipe shall meet ASTM F2648.
- Manning’s “n” value for use in design shall be 0.012.

Joint Performance

Pipe shall be joined with coupling bands covering at least two full corrugations on each end of the pipe. Standard connections shall meet or exceed the soil-tight requirements of ASTM F2648.

Gasketed connections shall incorporate a closed-cell synthetic expanded rubber gasket meeting the requirements of ASTM D1056 Grade 2A2. Gaskets, when applicable, shall be installed by the pipe manufacturer.

Fittings

Fittings shall conform to ASTM F2306.

Material Properties

Material for pipe production shall be an engineered compound of virgin and recycled high density polyethylene conforming with the minimum requirements of cell classification 424420C (ESCR Test Condition B) for 4- through 10-inch (100 to 250 mm) diameters, and 435420C (ESCR Test Condition B) for 12- through 60-inch (300 to 1500 mm) diameters, as defined and described in the latest version of ASTM D3350, except that carbon black content should not exceed 4%. The design engineer shall verify compatibility with overall system including structural, hydraulic, material, and installation requirements for a given application.

Installation

Installation shall be in accordance with ASTM D2321 and ADS recommended installation guidelines, with the exception that minimum cover in trafficked areas for 4- through 48-inch (100 to 1200 mm) diameters shall be one foot (0.3 m) and for 60-inch (1500 mm) diameter the minimum cover shall be 2 ft. (0.6 m) in single run applications. Backfill for minimum cover situations shall consist of Class 1 (compacted) or Class 2 (minimum 90% SPD) material. Maximum fill heights depend on embedment material and compaction level; please refer to Technical Note 2.02. Contact your local ADS representative or visit our website at www.adspipe.com for a copy of the latest installation guidelines.

Pipe Dimensions

Pipe I.D. in (mm)	4 (100)	6 (150)	8 (200)	10 (250)	12 (300)	15 (375)	18 (450)	24 (600)	30 (750)	36 (900)	42 (1050)	48 (1200)	60 (1500)
Pipe O.D.* in (mm)	4.8 (122)	6.9 (175)	9.1 (231)	11.4 (290)	14.5 (368)	18 (457)	22 (559)	28 (711)	36 (914)	42 (1067)	48 (1219)	54 (1372)	67 (1702)

*Pipe O.D. values are provided for reference purposes only, values stated for 12 through 60-inch are ±1 inch. Contact a sales representative for exact values

**All diameters available with or without perforations.

LANDMAX® RETENTION/DETENTION PIPE SYSTEM SPECIFICATION

Scope

This specification describes LandMax Retention/Detention Pipe Systems for use in non-pressure gravity-flow storm water collection systems utilizing a continuous outfall structure.

Pipe Requirements

Retention/Detention systems may utilize any of the various pipe products below:

- N-12® ST IB pipe (per AASHTO) shall meet AASHTO M294, Type S or ASTM F2306
- N-12 ST IB pipe (per ASTM F2648) shall meet ASTM F2648
- N-12 MEGA GREEN™ ST IB shall meet ASTM F2648
- N-12 WT IB pipe (per AASHTO) shall meet AASHTO M294, Type S or ASTM F2306
- N-12 WT IB pipe (per ASTM F2648) shall meet ASTM F2648
- N-12 MEGA GREEN™ WT IB shall meet ASTM F2648

All products shall have a smooth interior and annular exterior corrugations. All ST IB pipe products are available as perforated or non-perforated. WT IB pipe products are only available as non-perforated.

Product-specific pipe specifications are available in the Drainage Handbook Section 1 *Specifications*.

Joint Performance

Plain End/Soil-tight (ST IB)

ST IB pipe shall be joined using a bell & spigot joint. The bell & spigot joint shall meet the soil-tight requirements of ASTM F2306 and gaskets shall meet the requirements of ASTM F477.

Plain End pipe & fittings connections shall be joined with coupling bands covering at least two full corrugations on each end of the pipe. Gasketed soil-tight coupling band connections shall incorporate a closed-cell synthetic expanded rubber gasket meeting the requirements of ASTM D1056 Grade 2A2. Gaskets, when applicable, shall be installed by the pipe manufacturer.

Watertight (WT IB):

WT IB pipe shall be joined using a bell & spigot joint. The joint shall be watertight according to the requirements of ASTM D3212. Gaskets shall meet the requirements of ASTM F477. 12- through 60-inch (300 to 1500 mm) diameters shall have an exterior bell wrap installed by the manufacturer.

Pipe & fitting connections shall be with a bell and spigot connection utilizing a welded bell and valley or saddle gasket. The joint shall meet the watertight requirements of ASTM D3212 and gaskets shall meet the requirements of ASTM F477. Detention systems are subject to greater leakage than typical single run storm sewer application and therefore are not appropriate for applications requiring long-term fluid containment or hydrostatic pressure. For additional details refer to Technical Note 7.01 *Rainwater Harvesting with HDPE Cisterns*.

Fittings

Fittings shall conform to ASTM F2306 and meet joint performance requirements indicated above for fitting connections. Custom fittings are available and may require special installation criterion.

Installation

Installation shall be in accordance with ASTM D2321 and ADS recommended installation guidelines, with the exception that minimum cover in non-traffic areas for 12- through 60-inch (300 to 1500mm) diameters shall be one foot (0.3m). Minimum cover in trafficked areas for 12- through 36-inch (300 to 900mm) diameters shall be one foot (0.3m) and for 42- through 60-inch (1050 to 1500mm) diameters, the minimum cover shall be two feet (0.6m). Backfill shall consist of Class 1 (compacted) or Class 2 (minimum 90% SPD) material, with the exception that 60-inch fittings shall use Class 1 (compacted) material only. Minimum cover heights do not account for pipe buoyancy. Refer to ADS Technical Note 5.05 HDPE Pipe Flotation for buoyancy design considerations. Maximum cover over system using standard backfill is 8 feet (2.4m); contact a representative when maximum fill height may be exceeded.

Additional installation requirements are provided in the Drainage Handbook Section 6 Retention/Detention.

TYPICAL RETENTION/DETENTION CROSS SECTION

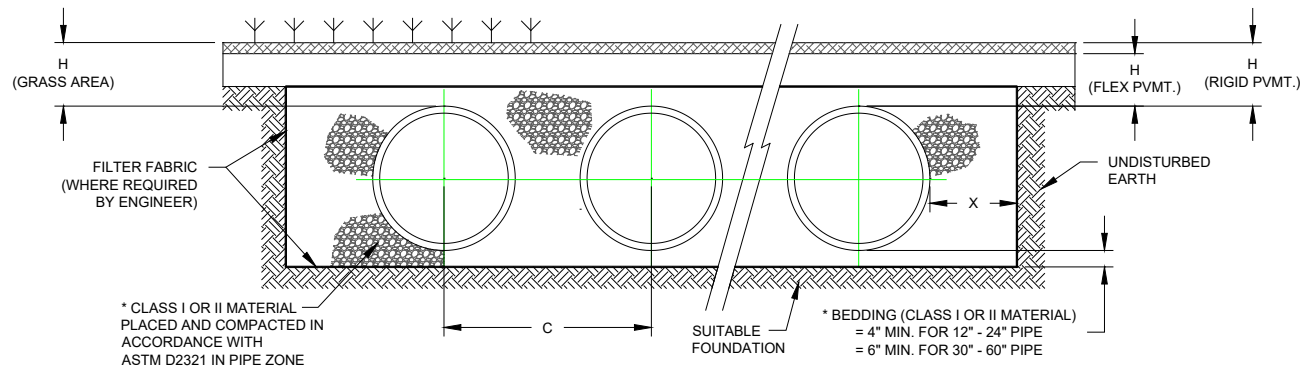

MINIMUM H (GRASS) = 12" FOR 12" THROUGH 60" HDPE PIPE
 MINIMUM H (FLEX PVMT), H (RIGID PVMT) = 12" FOR UP TO AND INCLUDING 36" HDPE PIPE
 = 24" FOR 42" THROUGH 60" HDPE PIPE

* CLASS I BACKFILL REQUIRED AROUND 60" DIAMETER FITTINGS.

MAXIMUM FILL HEIGHT LIMITED TO 8-FT OVER FITTINGS FOR STANDARD INSTALLATIONS. CONTACT REPRESENTATIVE WHEN MAXIMUM FILL HEIGHTS EXCEED 8-FT FOR INSTALLATION CONSIDERATIONS.

ADDITIONAL REFERENCES

Drainage Handbook Section 6 *Retention/Detention*

Technical Note 6.01 *Retention/Detention System Maintenance*

Technical Note 7.01 *Rainwater Harvesting with HDPE Pipe*

Standard Detail 701 *Retention-Detention System (Plan View)*

Standard Detail 702 *Retention-Detention System (Cross-Section)*

Standard Detail 703 *Retention-Detention System (Riser & Cleanout)*

Standard Detail 704 *Flowable Fill Installation (Nyloplast Riser)*

All references are available for download at www.adspipe.com

HP STORM 12”- 60” PIPE SPECIFICATION

Scope

This specification describes 12- through 60-inch (300 to 1500 mm) HP Storm pipe for use in gravity-flow storm drainage applications.

Pipe Requirements

HP Storm pipe shall have a smooth interior and annular exterior corrugations.

- 12- through 60-inch (300 to 1500 mm) pipe shall meet ASTM F2881 or AASHTO M330
- Manning’s “n” value for use in design shall be 0.012

Joint Performance

Pipe shall be joined using a bell & spigot joint meeting the requirements of ASTM F2881 or AASHTO M330. The joint shall be watertight according to the requirements of ASTM D3212. Gaskets shall meet the requirements of ASTM F477. Gasket shall be installed by the pipe manufacturer and covered with a removable, protective wrap to ensure the gasket is free from debris. A joint lubricant available from the manufacturer shall be used on the gasket and bell during assembly. 12- through 60-inch (300 to 1500 mm) diameters shall have an exterior bell wrap installed by the manufacturer.

Fittings

Fittings shall conform to ASTM F2881 or AASHTO M330. Bell and spigot connections shall utilize a welded or integral bell and valley or inline gaskets meeting the watertight joint performance requirements of ASTM D3212.

Field Pipe and Joint Performance

To assure watertightness, field performance verification may be accomplished by testing in accordance with ASTM F1417 or ASTM F2487. Appropriate safety precautions must be used when field-testing any pipe material. Contact the manufacturer for recommended leakage rates.

Material Properties

Polypropylene compound for pipe and fitting production shall be impact modified copolymer meeting the material requirements of ASTM F2881, Section 5 and AASHTO M330, Section 6.1.

Installation

Installation shall be in accordance with ASTM D2321 and ADS recommended installation guidelines, with the exception that minimum cover in traffic areas for 12- through 48-inch (300 to 1200 mm) diameters shall be one foot (0.3 m) and for 60-inch (1500 mm) diameter the minimum cover shall be 2 ft. (0.6 m) in single run applications. Backfill for minimum cover situations shall consist of Class 1 (compacted), Class 2 (minimum 90% SPD), or Class 3 (minimum 95%) material. Maximum fill heights depend on embedment material and compaction level; please refer to Technical Note 2.04. Contact your local ADS representative or visit our website at www.adspipe.com for a copy of the latest installation guidelines.

Build America, Buy America (BABA)

HP Storm pipe (per AASHTO), manufactured in accordance with ASTM F2881 or AASHTO M330, complies with the requirements in the Build America, Buy America (BABA) Act.

Pipe Dimensions

Nominal Pipe I.D. in (mm)	12 (300)	15 (375)	18 (450)	24 (600)	30 (750)	36 (900)	42 (1050)	48 (1200)	60 (1500)
Average Pipe I.D. in (mm)	12.2 (310)	15.1 (384)	18.2 (462)	24.1 (612)	30.2 (767)	36.0 (914)	42.0 (1067)	47.9 (1217)	59.9 (1521)
Average Pipe O.D. in (mm)	14.5 (368)	17.7 (450)	21.4 (544)	28.0 (711)	35.5 (902)	41.5 (1054)	47.4 (1204)	54.1 (1374)	67.1 (1704)
Minimum Pipe Stiffness * @ 5% Deflection #/in./in. (kN/m ²)	75 (517)	60 (414)	56 (386)	50 (345)	46 (317)	40 (276)	35 (241)	35 (241)	30 (207)

*Minimum pipe stiffness values listed; contact a representative for average values.

SANITITE® HP 12”- 60” PIPE SPECIFICATION

Scope

This specification describes 12- through 60-inch (300 to 1500 mm) SaniTite HP pipe for use in gravity-flow sanitary sewer applications.

Pipe Requirements

12”-30” (300 to 750mm) SaniTite HP dual wall pipe shall have a smooth interior and annular exterior corrugations; 30”-60” (750 to 1500mm) SaniTite HP triple wall pipe shall have a smooth interior and exterior surfaces with annular inner corrugations.

- 12- through 30-inch (300 to 750 mm) dual wall pipe shall meet ASTM F2764
- 30- through 60-inch (750 to 1500 mm) triple wall pipe shall meet ASTM F2764
- 12- through 60-inch (300 to 1500 mm) pipe shall have a minimum pipe stiffness of 46 pii when tested in accordance with ASTM D2412.
- Manning's “n” value for use in design shall be 0.012.

Joint Performance

Pipe shall be joined using a bell and spigot joint meeting the requirements of ASTM F2764. The joint shall be watertight according to the requirements of ASTM D3212, with the addition of a 15 psi pressure requirement. Gaskets shall meet the requirements of ASTM F477. Gaskets shall be installed by the pipe manufacturer and covered with a removable, protective wrap to ensure the gaskets are free from debris. A joint lubricant available from the manufacturer shall be used on the gasket and bell during assembly. 12- through 60-inch (300 to 1500 mm) diameters shall have a reinforced bell with a polymer composite band installed by the manufacturer.

Fittings

Fittings shall conform to ASTM F2764. Bell and spigot connections shall utilize a welded or integral bell and valley or inline gaskets meeting the watertight joint performance requirements of ASTM D3212.

Field Pipe and Joint Performance

To assure watertightness, field performance verification may be accomplished by testing in accordance with ASTM F1417 or ASTM F2487. Appropriate safety precautions must be used when field-testing any pipe material. Contact the manufacturer for recommended leakage rates.

Material Properties

Polypropylene compound for pipe and fitting production shall be an impact modified copolymer meeting the material requirements of ASTM F2764.

Installation

Installation shall be in accordance with ASTM D2321 and ADS recommended installation guidelines, with the exception that minimum cover in traffic areas for 12- through 48-inch (300 to 1200 mm) diameters shall be one foot (0.3 m) and for 60-inch (1500mm) diameter the minimum cover shall be 2-ft (0.6m) in single run applications. Backfill for minimum cover situations shall consist of Class 1 (compacted) or Class 2 (minimum 90% SPD) material. Maximum fill heights depend on embedment material and compaction level; please refer to Technical Note 2.05. Contact your local ADS representative or visit our website at www.adspipe.com for a copy of the latest installation guidelines.

Build America, Buy America (BABA)

SaniTite HP pipe, manufactured in accordance with ASTM F2764, complies with the requirements in the Build America, Buy America (BABA) Act.

Pipe Dimensions

Nominal Pipe I.D. in (mm)	12 (300)	15 (375)	18 (450)	24 (600)	30 (750)	36 (900)	42 (1050)	48 (1200)	60 (1500)
Average Pipe I.D. in (mm)	12.1 (307)	14.9 (378)	18.0 (457)	24.1 (612)	30.1 (765)	35.7 (907)	41.8 (1062)	47.3 (1201)	59.3 (1506)
Average Pipe O.D. in (mm)	14.5 (368)	17.6 (447)	21.2 (538)	28.0 (711)	35.5 (902)	41.5 (1054)	47.4 (1199)	54.1 (1374)	67.1 (1705)

*OD values listed above are NOT for manhole connector sizing. See ADS Standard Detail 205A-F for the recommended manhole connector based on product and diameter.

N-12[®] LOW HEAD PIPE SPECIFICATION

Scope

This specification describes 24- through 60-inch (600 to 1500 mm) N-12 Low Head pipe for use in low head / low pressure applications.

Pipe Requirements

N-12 Low Head pipe shall have a smooth interior and annular exterior corrugations.

- 24- through 60-inch (600 to 1500 mm) pipe shall meet AASHTO M294, Type S or ASTM F2306 with the modifications listed herein.
- Manning's "n" value for use in design shall be 0.012.
- Where low head applications sustain continuous pressure, the sustained pressure shall not exceed 5psi and the surge pressure shall not exceed 10 psi.

Joint Performance

Pipe shall be joined using a bell and spigot joint meeting the requirements of AASHTO M294 or ASTM F2306. The joint shall be watertight according to the requirements of ASTM D3212. Gaskets shall meet the requirements of ASTM F477. Gaskets shall be installed by the pipe manufacturer and covered with a removable, protective wrap to ensure the gaskets are free from debris. A joint lubricant available from the manufacturer shall be used on the gasket and bell during assembly. 12- through 60-inch (300 to 1500 mm) diameters shall have a reinforced bell with a polymer composite band installed by the manufacturer.

Fittings

Fittings shall conform to AASHTO M294 or ASTM F2306. Bell & spigot connections shall utilize a welded or integral bell & inline, valley or saddle gaskets meeting watertight joint performance requirements of ASTM D3212.

Field Pipe and Joint Performance

To assure watertightness, field performance verification may be accomplished by testing in accordance with ASTM F1417 or ASTM F2487. Appropriate safety precautions must be used when field-testing any pipe material. Contact the manufacturer for recommended leakage rates.

Material Properties

Material for pipe and fitting production shall be high-density polyethylene conforming with the minimum requirements of cell classification 435400C for the corrugated exterior profile, and 445464C, for the interior liner as defined and described in the latest version of ASTM D3350, except that carbon black content should not exceed 4%. The 24- through 60-inch (600 to 1500mm) pipe material shall comply with the notched constant ligament-stress (NCLS) test as specified in Sections 9.4 and 5.1 of AASHTO M294 and ASTM F2306 respectively. The interior liner resin shall have a material designation code of PE3408/PE3608 by the Plastic Pipe Institute and a Hydrostatic Design Basis of 1600 psi.

Installation

Installation shall be in accordance with ASTM D2321 and ADS recommended installation guidelines, with the exceptions that minimum cover in traffic areas for 24- through 48-inch (600 to 1200mm) diameters shall be one foot (0.3m) and for 60-inch (1500mm) diameter the minimum cover shall be 2-feet (0.6m) in single run applications. Backfill for minimum cover situations shall consist of Class 1 (compacted) or Class 2 (minimum 90% SPD) material. Maximum fill heights depend on embedment material and compaction level; please refer to Technical Note 2.01. Contact your local ADS representative or visit our website at www.adspipe.com for a copy of the installation guidelines.

Build America, Buy America (BABA)

N-12 Low Head pipe, manufactured in accordance with AASHTO M294 or ASTM F2306, complies with the requirements in the Build America, Buy America (BABA) Act.

Pipe Dimensions

Pipe I.D. in (mm)	24 (600)	30 (750)	36 (900)	42 (1050)	48 (1200)	60 (1500)
Pipe O.D.* in (mm)	27.8 (719)	36 (914)	42 (1067)	48 (1219)	54 (1372)	67 (1702)
Minimum Pipe Stiffness @ 5% Deflection #/in./in. (kN/m ²)	28 (195)	28 (195)	22 (150)	20 (140)	18 (125)	14 (95)

SINGLE WALL PIPE SPECIFICATION

Scope

This specification describes 3- through 15-inch (75 to 375 mm) single wall high density corrugated polyethylene pipe for use in gravity-flow land drainage applications.

Pipe Requirements

Single wall high density corrugated polyethylene pipe shall have annular interior and exterior corrugations.

- 3- through 15-inch (75 to 375 mm) pipe shall meet ASTM F667.

Joint Performance

Joints for 3- to 15- inch (75 – 375 mm) shall be made with split or snap couplings. Standard connections shall meet the requirements of the ASTM F667. Gasketed connections shall incorporate a closed-cell synthetic expanded rubber gasket meeting the requirements of ASTM D1056 Grade 2A2. Gaskets, when applicable, shall be installed by the pipe manufacturer.

Fittings

Fittings shall conform to ASTM F667.

Material Properties

Pipe and fitting material shall be high density polyethylene conforming with the minimum requirements of cell classification 323410C or 333410C as defined and described in the latest version of ASTM D3350.

Installation

Installation shall be in accordance with ASTM D2321 and ADS recommended installation guidelines, with the exception that minimum cover in trafficked areas for 3- through 15-inch (75 to 375 mm) diameters shall be one foot (0.3 m). Maximum fill heights depend on embedment material and compaction level; please refer to Technical Note 2.03. Contact your local ADS representative or visit our website at www.adspipe.com for a copy of the installation guidelines.

Pipe Dimensions

Pipe I.D. in (mm)	3 (75)	4 (100)	5 (125)	6 (150)	8 (200)	10 (250)	12 (300)	15 (375)
Pipe O.D.* in (mm)	3.6 (91)	4.6 (117)	5.8 (147)	7.0 (178)	9.5 (241)	12.0 (305)	14.5 (368)	18.0 (457)

*Pipe O.D. values are provided for reference purposes only, values stated for 12 through 24-inch are ±1 inch. Contact a sales representative for exact values

**All diameters available with or without perforations.

SINGLE WALL HEAVY DUTY PIPE SPECIFICATION

Scope

This specification describes 3- through 15-inch (75 to 375 mm) single wall high density corrugated polyethylene heavy duty pipe for use in gravity-flow land drainage applications.

Pipe Requirements

Single wall high density corrugated polyethylene heavy duty pipe shall have annular interior and exterior corrugations.

- 3- through 15-inch (75 to 375 mm) pipe shall meet ASTM F667.

Joint Performance

Joints for 3- to 15- inch (75 – 375 mm) shall be made with split or snap couplings. Standard connections shall meet the requirements of the ASTM F667. Gasketed connections shall incorporate a closed-cell synthetic expanded rubber gasket meeting the requirements of ASTM D1056 Grade 2A2. Gaskets, when applicable, shall be installed by the pipe manufacturer.

Fittings

Fittings shall conform to ASTM F667.

Material Properties

Pipe and fitting material shall be high density polyethylene conforming with the minimum requirements of cell classification 323410C or 333410C as defined and described in the latest version of ASTM D3350.

Installation

Installation shall be in accordance with ASTM D2321 and ADS recommended installation guidelines, with the exception that minimum cover in trafficked areas for 3- through 15-inch (75 to 375 mm) diameters shall be one foot (0.3 m). Maximum fill heights depend on embedment material and compaction level; please refer to Technical Note 2.03. Contact your local ADS representative or visit our website at www.adspipe.com for a copy of the installation guidelines.

Pipe Dimensions

Pipe I.D. in (mm)	3 (75)	4 (100)	5 (125)	6 (150)	8 (200)	10 (250)	12 (300)	15 (375)
Pipe O.D.* in (mm)	3.6 (91)	4.6 (117)	5.8 (147)	7.0 (178)	9.5 (241)	12.0 (305)	14.5 (368)	18.0 (457)

*Pipe O.D. values are provided for reference purposes only, values stated for 12 through 24-inch are ±1 inch. Contact a sales representative for exact values

**All diameters available with or without perforations.

SINGLE WALL HIGHWAY PIPE SPECIFICATION

Scope

This specification describes 3- through 15-inch (75 to 375 mm) single wall high density corrugated polyethylene highway pipe, for use in gravity-flow land drainage applications.

Pipe Requirements

Single wall high density corrugated polyethylene highway pipe shall have annular interior and exterior corrugations.

- 3- through 10-inch (75 to 250 mm) pipe shall meet AASHTO M252, Type C or CP.
- 12- through 15-inch (300 to 375 mm) pipe shall meet AASHTO M294, Type C or CP.

Joint Performance

Joints for 3- to 15- inch (75 – 375 mm) shall be made with split or snap couplings. Standard connection shall meet the soil-tightness requirements of AASHTO M252 or M294. Gasketed connections shall incorporate a closed-cell synthetic expanded rubber gasket meeting the requirements of ASTM D1056 Grade 2A2. Gaskets, when applicable, shall be installed by the pipe manufacturer.

Fittings

Fittings shall conform to AASHTO M252 or AASHTO M294.

Material Properties

Pipe and fittings shall be made of polyethylene compounds that comply with the cell classification 424420C for 4- through 10-inch (100 to 250 mm) diameters, or 435400C for 12- through 15-inch (300 to 375 mm) diameters, as defined and described in ASTM D3350, except that carbon black content should not exceed 4%. The 12- through 15-inch (300 to 375 mm) pipe material shall comply with the notched constant ligament-stress (NCLS) test as specified in Sections 9.5 of AASHTO M294.

Installation

Installation shall be in accordance with ASTM D2321 and ADS recommended installation guidelines with the exception that minimum cover in trafficked areas for 3- through 15-inch (75 to 375 mm) diameters shall be one foot (0.3 m). Maximum fill heights depend on embedment material and compaction level; please refer to Technical Note 2.03. Contact your local ADS representative or visit our website at www.adspipe.com for a copy of the latest installation guidelines.

Build America, Buy America (BABA)

Single Wall Highway pipe, manufactured in accordance with AASHTO M252 or AASHTO M294, complies with the requirements in the Build America, Buy America (BABA) Act.

Pipe Dimensions

Pipe I.D. in (mm)	3 (75)	4 (100)	5 (125)	6 (150)	8 (200)	10 (250)	12 (300)	15 (375)
Pipe O.D.* in (mm)	3.6 (91)	4.6 (117)	5.8 (147)	7.0 (178)	9.5 (241)	12.0 (305)	14.5 (368)	18.0 (457)

*Pipe O.D. values are provided for reference purposes only, values stated for 12 through 24-inch are ±1 inch. Contact a sales representative for exact values

**All diameters available with or without perforations.

GRAIN-AIRE® PIPE SPECIFICATION

Scope

This specification describes 18- through 36-inch (450 to 900 mm) Grain-Aire pipe for use in metering air and providing uniform flow air in flat storage structures.

Pipe Requirements

Grain-Aire pipe shall have a smooth interior and annular exterior corrugations covered with a polypropylene protective screen to provide unrestricted air flow.

Joint Performance

Pipe shall be joined with split or snap couplers covering at least two full corrugations on each end of the pipe.

Material Properties

Pipe and fittings shall be high density polyethylene conforming with the minimum requirements of cell classification 424400C as defined and described in the latest version of ASTM D3350.

Perforations

Nominal Diameter	Corrugations Per Foot	Number of Holes Per Foot	Min. Hole Diameter	Open Area Per Foot
18" (450 mm)	4.7	24	5/8" (16 mm)	7.36
24" (600 mm)	4.7	24	5/8" (16 mm)	7.36
30" (750 mm)	2.9	32	1/2" (13 mm)	6.28
36" (900 mm)	2.4	32	1/2" (13 mm)	6.28

Protective Screen

Material	Polypropylene	Test Method
Bursting Strength (lbs/in ²)	484	ASTM D3786
Weight (oz/yd ²)	5.3	ASTM D3776
% Open Area	25	ASTM D475
Tensile Strength (lbs) (Grab Test)	425 (Wrap)	ASTM D5034
	273 (Fill)	

ADVANEDGE® PIPE SPECIFICATION

Scope

This specification describes 12-inch (300 mm) AdvanEdge oblong corrugated pipe for use in subsurface drainage applications.

Product Requirements

AdvanEdge shall have annular interior and exterior corrugations.

- 12-inch (300 mm) shall meet ASTM D7001.

AdvanEdge outside dimensions shall be 1.5" (38 mm) thick x 12.5" (318 mm) wide. AdvanEdge shall have internal bracing adjoining each long wall to prevent crushing under typical loading. AdvanEdge shall be made available with or without an external geotextile wrap.

When geotextile is provided, product shall meet the requirements of Class B Geocomposite as defined in ASTM D7001.

Material Properties

All pipe and fittings shall be made of polyethylene with a minimum cell classification of 424420C as defined and described in the latest version of ASTM D3350.

Perforations

Nominal Pipe Size, in (mm)	12 (300)
Slot Length (avg.), in (mm)	1.125 (29)
Slot Width (avg.), in (mm)	0.125 (3.2)
Water Inlet Area (approx.), In ² /ft	15

Filter Fabric

	ASTM D4632	112
	ASTM D4632	50
	ASTM D4533	40
	ASTM D4833	40
	ASTM D4491	0.5
	ASTM D4751	60
	ASTM D4355	50

SB2® PIPE SPECIFICATION

Scope

This specification describes SB2 pipe available in 8- and 10-inch (200 and 250 mm) diameters for use in on-site waste disposal applications.

Pipe Requirements

SB2 pipe shall have a corrugated interior and corrugated exterior a pre-installed septic fabric.

- 8- and 10-inch (200 and 250 mm) pipe shall meet the requirements of ASTM F667.
- There shall be two ½ inch (12.7 mm) holes 120 degrees apart on the length of the pipe.
- The 8-inch (200 mm) and 10-inch (250mm) pipe shall have 1.0 square inches per foot of open area.

Joint Performance

Pipe shall be joined with internal or external snap couplers covering at least two full corrugations on each end of the pipe.

Fittings

Fittings shall conform to ASTM F667.

Material Properties

Pipe material shall be high density polyethylene conforming with the minimum requirements of cell classification 424410C as defined and described in the latest version of ASTM D3350; or ASTM D1248 Type III, Class C, Category 4, Grade P33.

Filter Fabric Properties

Material	Nylon (100%)
Fabric	Spun Bond
Fiber Size (denier per filament)	5
Weight (ounces per yd ² , ASTM D3776)	0.85
Burst Strength (pounds per in ² , ASTM D3786)	28
Air Permeability (CFM per ft ² , ASTM D737)	650
Equivalent Opening Size (Army Corps of Engineers, W 02215)	50
Water Flow Rate (gal/min/ft ² , ASTM D4491)	163
Melt Temperature (ASTM D3786)	218° C (425° F)

Installation

Installation shall be in accordance with ADS recommended installation instructions and those issued by a local health department. For leachfield applications, installation shall be in accordance with ASTM F481 and as regulated by regional, state, and local agencies. Proper authorization for specific applications and designs should be obtained prior to installation to ensure suitability in certain locales. Contact your local ADS representative or visit our website at www.adspipe.com for a copy of the installation guidelines.

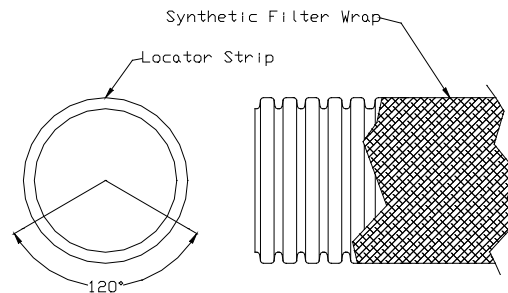

ADS 3000 TRIPLEWALL® PIPE SPECIFICATION

Scope

This specification describes 4-inch (100 mm) ADS 3000 TripleWall pipe for use in gravity-flow drainage and leach field applications.

Pipe Requirements

ADS 3000 TripleWall pipe shall have a smooth interior and exterior.

- 4-inch (100 mm) pipe shall meet the requirements of ASTM F810.
- Manning's "n" value for use in design shall not be less than 0.009.

Joint Performance

Pipe joints shall be bell-and-spigot. Bell ends shall be integrally formed on the pipe at one end to form a soil-tight connection.

Material Properties

Pipe material shall be high-density polyethylene conforming with the minimum requirements of cell classifications 424410C or E as defined and described in the latest version of ASTM D3350. The material formulation shall include recycled polyethylene.

Installation

For gravity-flow drainage applications, installation shall be in accordance with ASTM D2321 and ADS recommended installation guidelines with the exception that minimum cover in traffic areas shall be one foot (0.3 m). For leachfield applications, installation shall be in accordance with ASTM F481 and as regulated by regional, state, and local agencies. Proper authorization for specific applications and designs should be obtained prior to installation to ensure suitability in certain locales. Contact your local ADS representative or visit our website at www.adspipe.com for a copy of the installation guidelines.

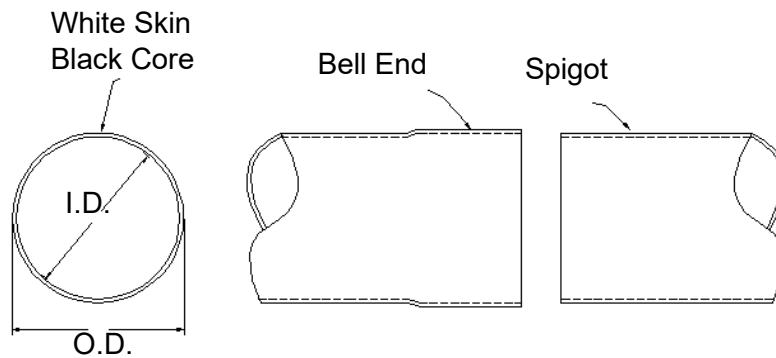

Perforation Options*

Nominal Pipe I.D. in (mm)	4 (100)
Average Pipe I.D. in (mm)	3.875 (98.5)
Average Pipe O.D. in (mm)	4.215 (107)

*Only available in a limited area. Check with your sales representative for availability.

**Perforation sizes are based on customer requirements and availability by region.

**All diameters available with or without perforations

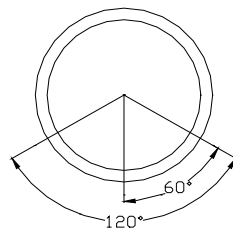

Option 1:
3 Hole, 120°

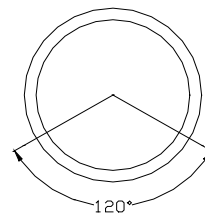

Option 2:
2 Hole, 120°

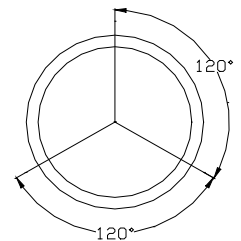

Option 3:
3 Hole, 360°

SMOOTHWALL SEWER & DRAIN PIPE SPECIFICATIONS

Scope

This specification describes Smoothwall Sewer & Drain pipe in 3- and 4-inch (75 and 100 mm) diameters for use in gravity flow drainage and leach field applications.

Pipe Requirements

Smoothwall Sewer & Drain pipe shall have a smooth interior and exterior.

- 3- and 4-inch (75 and 100 mm) pipe shall meet the requirements of ASTM F810.
- Manning's "n" value for use in design shall not be less than 0.009.

Joint Performance

Pipe joints shall be bell-and-spigot. Bell ends shall be integrally formed on the pipe at one end to form a soil-tight connection.

Material Properties

Pipe material shall be high-density polyethylene conforming with the minimum requirements of cell classifications 424410C or E as defined and described in the latest version of ASTM D3350. The material formulation shall include recycled polyethylene.

Installation

For gravity-flow drainage applications, installation shall be in accordance with ASTM D2321 and ADS recommended installation guidelines with the exception that minimum cover in traffic areas shall be one foot (0.3 m). For leachfield applications, installation shall be in accordance with ASTM F481 and as regulated by regional, state, and local agencies. Proper authorization for specific applications and designs should be obtained prior to installation to ensure suitability in certain locales. Contact your local ADS representative or visit our website at www.adspipe.com for a copy of the latest installation guidelines.

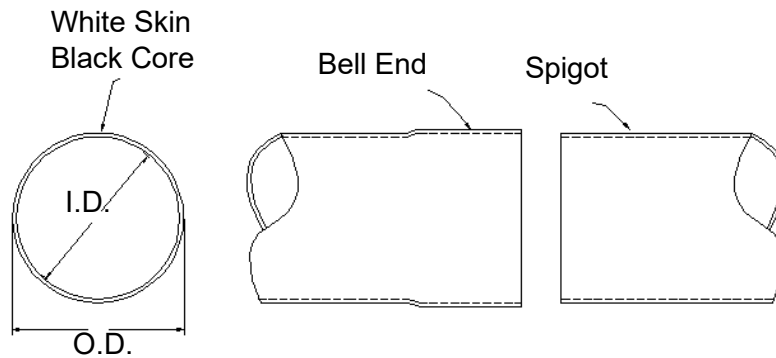

Perforation Options**

Nominal Pipe I.D. in (mm)	3 (75)	4 (100)
Average Pipe O.D. in (mm)	3.250 (83)	4.215 (107)
SDR Rating*	38	38
Pipe Stiffness pij (kPa)	19 (131)	11 (76)

*Check with a sales representative for availability by region; other SDR rated pipe may be available.

**Perforation sizes are based on customer requirements and availability by region.

***All diameters available with or without perforations

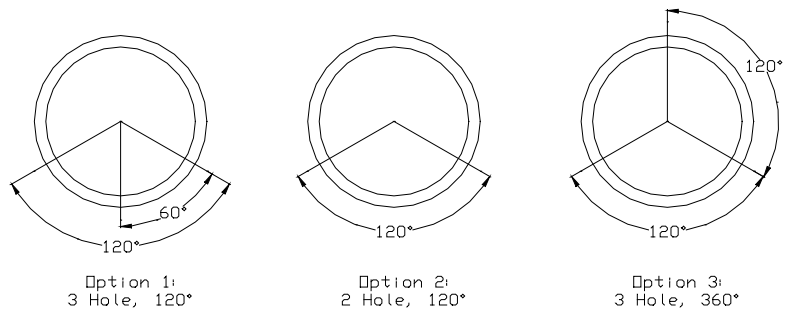

CHANNEL-FLOW® PIPE SPECIFICATIONS

Scope

This specification describes Channel-Flow pipe in 4-inch (100 mm) diameter for use in on-site waste applications.

Pipe Requirements

Channel-Flow pipe shall have a corrugated interior and corrugated exterior.

- 4-inch (100 mm) pipe shall meet the requirements of ASTM F667 and SCS 606.
- Perforations shall be spaced every 4.2-inches (107 mm) on the length of the pipe.

Joint Performance

Pipe shall be joined with self-coupling stubs located at the ends of each pipe section.

Fittings

Fittings shall conform to ASTM F667.

Material Properties

Pipe material shall be high density polyethylene conforming with the minimum requirements of cell classification 424410C as defined and described in the latest version of ASTM D3350; or ASTM D1248 Type III, Class C, Category 4, Grade P33.

Installation

Installation shall be in accordance with ASTM F481 and those issued by the local health department.

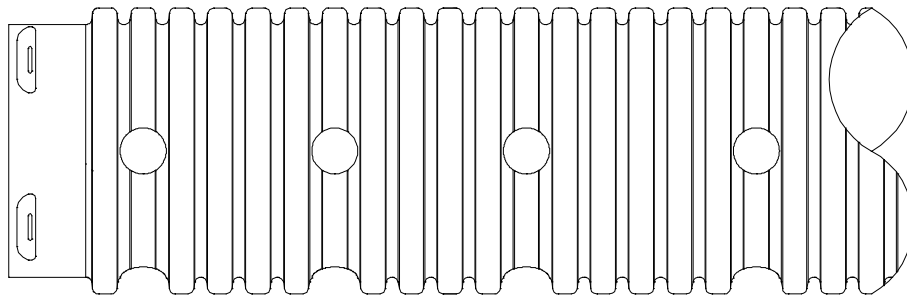

Perforation Options*

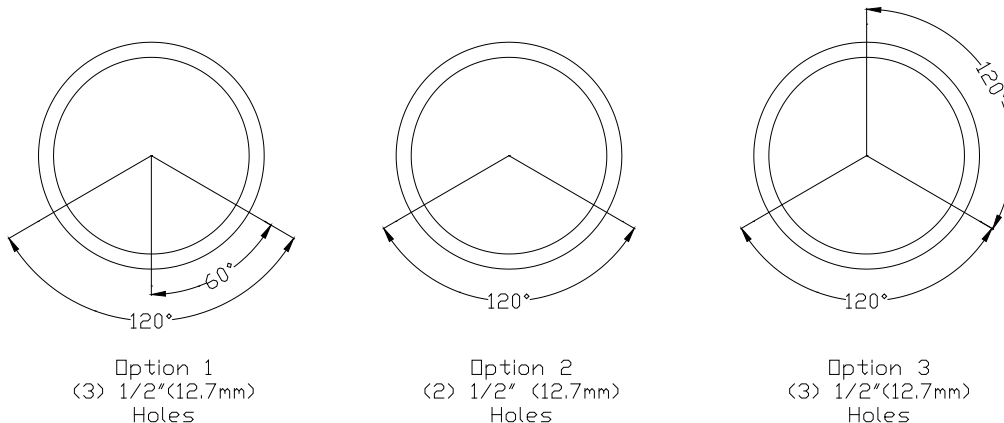

*Check with sales representative for perforation option availability by region.

CHANNEL-MUCK PIPE SPECIFICATIONS

Scope

This specification describes Channel-Muck pipe in 4- through 6-inch (100 to 150mm) diameters for use in agricultural drainage applications.

Pipe Requirements

Channel-Muck pipe shall have a corrugated interior and corrugated exterior.

- 4- through 6-inch (100 to 150mm) pipe shall meet the requirements of ASTM F667 and SCS 606.
- There shall be three perforations every 4.2-inch (107 mm) on the length of the pipe.

Joint Performance

Pipe shall be joined with self-coupling stubs located at the ends of each pipe section.

Fittings

Fittings shall conform to ASTM F667.

Material Properties

Pipe material shall be high density polyethylene conforming with the minimum requirements of cell classification 424410C as defined and described in the latest version of ASTM D3350; or ASTM D1248 Type III, Class C, Category 4, Grade P33.

Installation

Installation shall be in accordance with ADS recommended installation instructions and those issued by regional, state or local agencies.

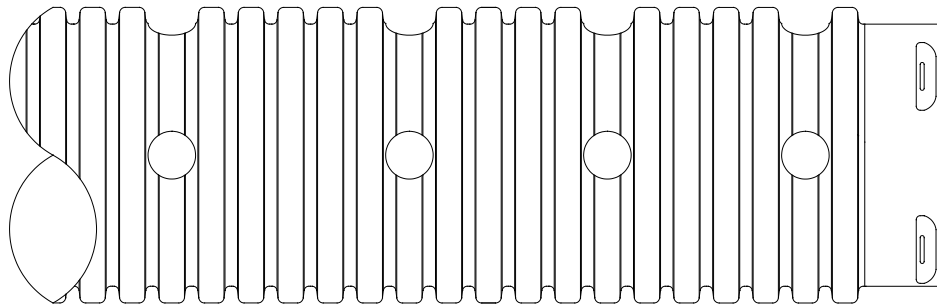

Perforation Options*

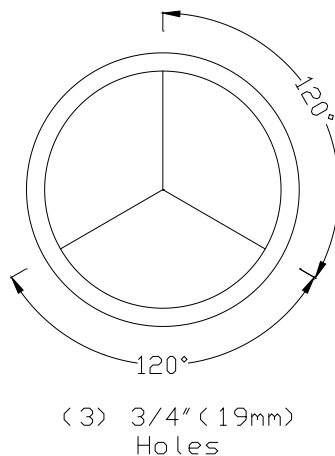

* Check with sales representative for perforation option availability by region.

DURASLOT® SLOTTED DRAIN SPECIFICATION

Scope

This specification describes 4- through 36-inch (100 to 900 mm) Duraslot slotted drain for use in surface drain and conveyance applications.

Pipe Requirements

Duraslot pipe, as manufactured and distributed by ADS, Inc., shall have a smooth interior and annular exterior corrugations with an aluminum slot grate frame mounted longitudinally along the length of the pipe to accept the grate while maintaining the original pipe diameter.

- 4- through 10-inch (100 to 250 mm) pipe shall meet AASHTO M252, Type S.
- 12- through 36-inch (300 to 900 mm) pipe shall meet AASHTO M294, Type S or ASTM F2306.
- Manning's "n" value for use in design shall be 0.012.

The aluminum slot grate frame shall be manufactured from 0.063-inch (1.6 mm) tempered commercial aluminum meeting the requirements of ASTM B209, consisting of two parallel plates separated by spacers spanning the slot on 6-inch (150 mm) centers. The aluminum slot grate frame shall be coated with a primer to protect the aluminum when installed in concrete. The grate shall be ½ - #13 galvanized steel or ½ - #13 304 stainless steel per ASTM F1267. Alternatively, aluminum slot grate may be left open top. The grate shall have diamond-shaped openings with a 52% open area and be ADA compliant. The flange at the bottom of the aluminum slot grate frame shall be riveted to the pipe with a minimum of two rivets per linear foot.

Fittings

Duraslot fittings shall be modified from fittings which conform to AASHTO M252, AASHTO M294 or ASTM F2306.

Build America, Buy America (BABA)

Duraslot pipe, manufactured in accordance with AASHTO M252, AASHTO M294 or ASTM F2306, complies with the requirements in the Build America, Buy America (BABA) Act.

Installation

Installation shall be in accordance with ADS recommended installation instructions. Contact your local ADS representative or visit www.adspipe.com for a copy of the latest installation guidelines.

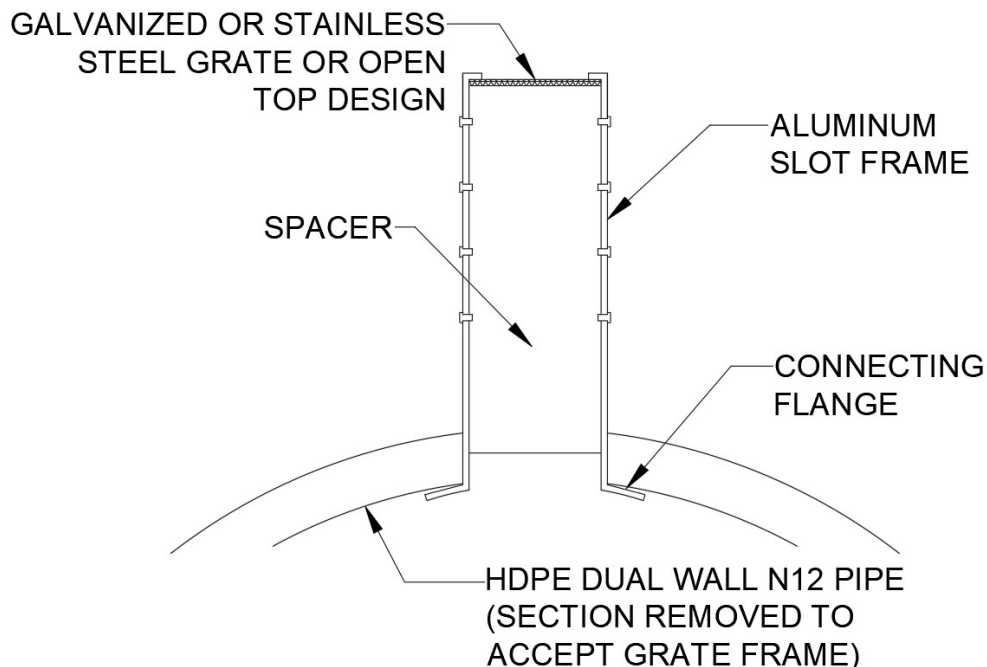

Duraslot Standard Dimensions

	Nominal Pipe Diameter in (mm)									
	4" (100)	6" (150)	8" (200)	10" (250)	12" (300)	15" (375)	18" (450)	24" (600)	30" (750)	36" (900)
L - Drain Grate Length)	118.0 (2997)					116.0 (2946)				
E - Pipe End Length	1.0 (25)					2.0 (51)				
H -.5" slot	2.75 (70)	3.0 (76)	3.0 (76)	3.0 (76)	3.5 (89)	3.75 (95)	4.0 (102)	4.75 (121)	5.0 (127)	5.25 (133)
H - 6.0" slot	6.25 (159)	6.5 (165)	6.5 (165)	6.5 (165)	7.0 (178)	7.0 (178)	7.0 (178)	7.25 (184)	8.25 (210)	8.25 (210)
O - Opening Width	1.25 (32)	1.75 (44)	1.75 (44)	1.75 (44)	1.75 (44)	1.75 (44)	1.75 (44)	1.75 (44)	1.75 (44)	1.75 (44)
S - Slot Width	1.75 (44)	2.25 (57)	2.25 (77)	2.25 (77)	2.25 (77)	2.25 (77)	2.25 (77)	2.25 (77)	2.25 (77)	2.25 (77)
W - Pipe Width with Corrugations	0.34 (9)	0.46 (12)	0.61 (15)	0.73 (19)	1.15 (29)	1.30 (33)	1.57 (40)	1.86 (47)	2.55 (65)	2.85 (72)

Note: Custom slot heights available upon request. Production of custom slots will require approval by the Duraslot Project Engineer. Signed shop drawings also required from interested party.

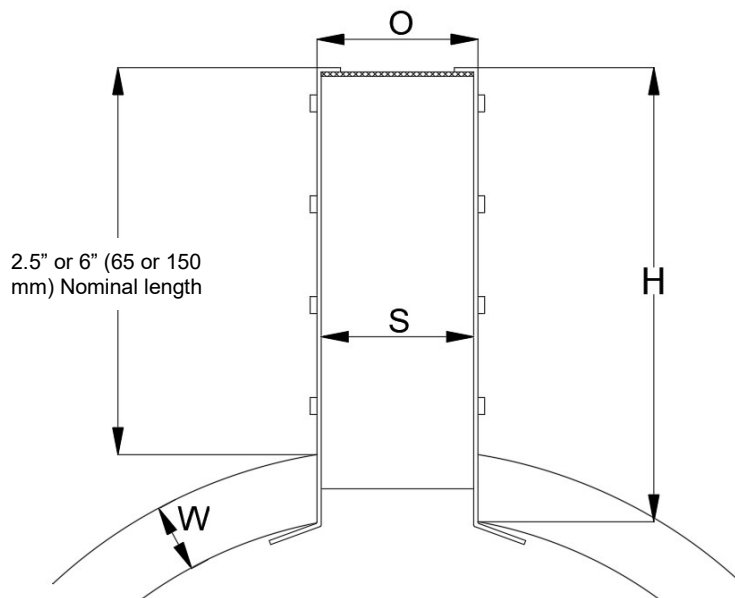
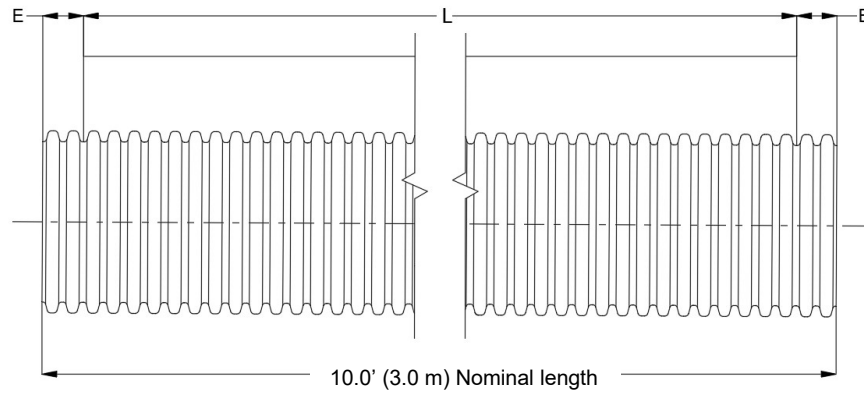

DURASLOT® XL SPECIFICATION

Scope

This specification describes 6- through 36-inch (150 to 900 mm) Duraslot XL pipe for use in surface drain and conveyance applications.

Pipe Requirements

Duraslot XL pipe, as manufactured and distributed by ADS, Inc., shall have a smooth interior and annular exterior corrugations with an aluminum slot grate frame mounted longitudinally along the length of the pipe to accept the grate, while maintaining the original pipe diameter.

- 6- through 10-inch (150 to 250 mm) pipe shall meet AASHTO M252, Type S.
- 12- through 36-inch (300 to 900 mm) pipe shall meet AASHTO M294, Type S or ASTM F2306.
- Manning's "n" value for use in design shall be 0.012.

The aluminum slot grate frame shall be manufactured from 0.063" (1.6 mm) tempered commercial aluminum meeting the requirements of ASTM B209, consisting of two parallel plates separated by spacers spanning the slot width. The aluminum slot grate frame shall be coated with a primer to protect the aluminum when installed in concrete. Grates furnished by ADS shall be made of ductile iron with a 4.81-inch (122 mm) width and 19.69-inch (500 mm) length. The grate pattern, open area and load rating will vary based on the chosen design. The flange at the bottom of the aluminum slot grate frame shall be riveted to the pipe with a minimum of two rivets per linear foot.

Fittings

Duraslot XL fittings shall be modified from fittings which conform to AASHTO M252, AASHTO M294 or ASTM F2306.

Installation

Installation shall be in accordance with ADS recommended installation instructions. Contact your local ADS representative or visit www.adspipe.com for a copy of the latest installation guidelines.

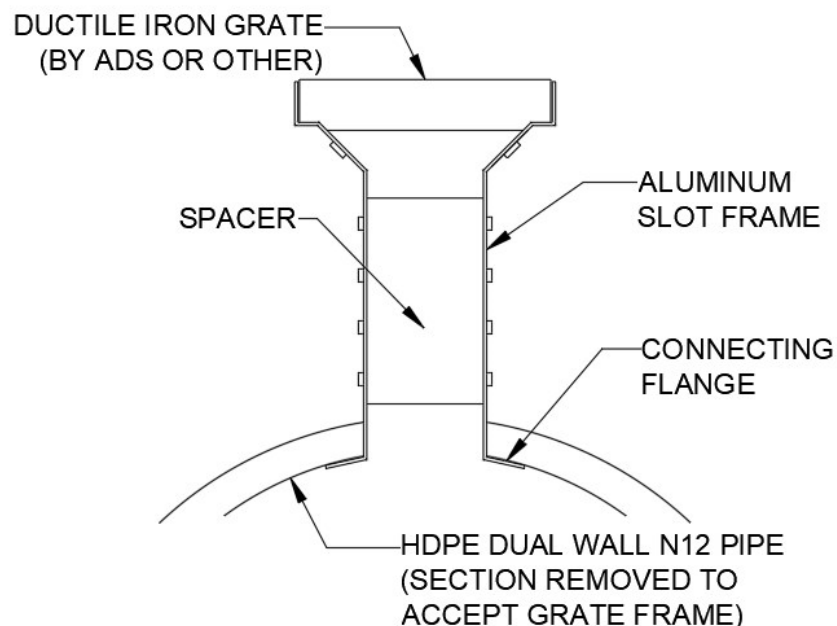

Duraslot XL Standard Dimensions

	Nominal Pipe Diameter in (mm)								
	6" (150)	8" (200)	10" (250)	12" (300)	15" (375)	18" (450)	24" (600)	30" (750)	36" (900)
L – Drain Grate Length	118.5 (3010)								
H – 2.5" (62.5 mm) Slot	3.0 (76)	3.0 (76)	3.0 (76)	3.5 (89)	3.75 (95)	4.0 (102)	4.75 (121)	5.0 (127)	5.25 (133)
H – 6.0" (160 mm) Slot	6.5 (165)	6.5 (165)	6.5 (165)	7.0 (178)	7.0 (178)	7.0 (178)	7.25 (184)	8.25 (210)	8.25 (210)
O – Opening Width	5.0 (127)								
R – Slot Width	0.316 (8)								
S – Slot Width	2.25 (57)								
W – Pipe Width with Corrugation	0.46 (12)	0.61 (15)	0.73 (19)	1.15 (29)	1.30 (33)	1.57 (40)	1.86 (47)	2.55 (65)	2.85 (72)

Note:

1. Custom slot heights available upon request. Production of custom slots will require approval by the Duraslot Project Engineer. Signed shop drawings also required from interested party.
2. Other grate material options available upon request. Contact local ADS representative for availability of grate material option.

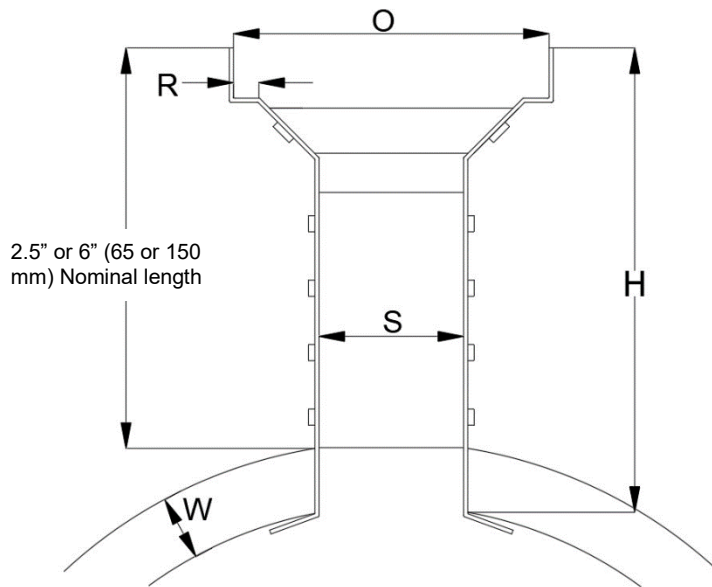
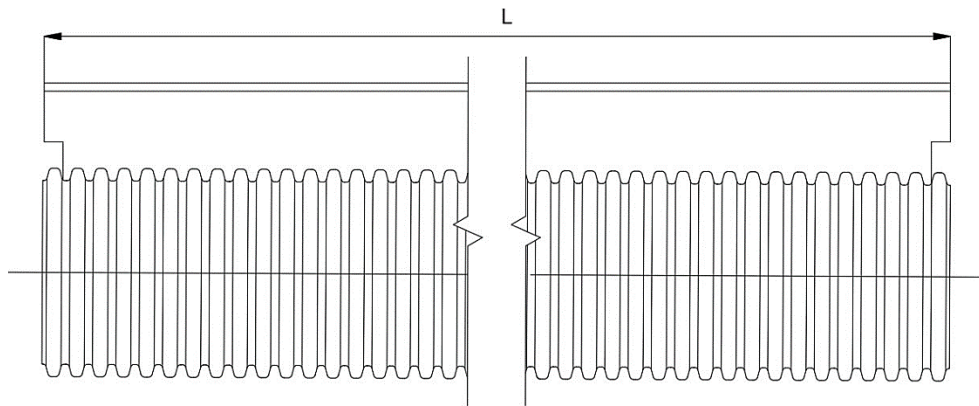

Note: 2.5" (65 mm) Standard Duraslot XL is available in 6" – 12" (150-300 mm) Ø pipe and 6" (150 mm) Standard Duraslot XL is available in 6" – 36" (150-900 mm) Ø pipe.



INJECTION MOLDED FITTING SPECIFICATION

Scope

This specification describes 4- through 12-inch (100 to 300 mm) Injection Molded Fittings for use in joining gravity-flow drainage and sewer pipe. Available fittings include tees, wyes, bends, couplers, and reducing fittings.

Fitting Requirements

Injection Molded Fittings shall have a smooth interior and exterior.

- 4- through 10-inch (100 to 250mm) shall meet the fitting requirements of AASHTO M252.
- 12-inch (300mm) shall meet AASHTO M294 or ASTM F2306.

Joint Performance

The fittings shall provide a joint meeting AASHTO M252, AASHTO M294 or ASTM F2306. For non-gasketed fittings, dimples in the bell shall engage the corrugation to provide a soil-tight connection. For gasketed fittings, the joint shall be watertight according to the requirements of ASTM D3212. Gaskets shall be made of EPDM meeting the requirements of ASTM F477. Gaskets shall be supplied by the pipe manufacturer. A joint lubricant supplied by the manufacturer shall be used on the gasket and bell during assembly.

Material Properties

Material for fitting production shall be high density polyethylene conforming with the minimum requirements of cell classification 314420C or 314420E for 4- through 12-inch (100 to 300mm) diameters, as defined and described in the latest version of ASTM D3350, except that carbon black content should not exceed 4%.

Build America, Buy America (BABA)

Injection Molded Fittings, manufactured in accordance with AASHTO M252, AASHTO M294 or ASTM F2306, complies with the requirements in the Build America, Buy America (BABA) Act.

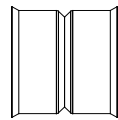

SIZE-ON-SIZE OR REDUCING
BELL-BELL COUPLER

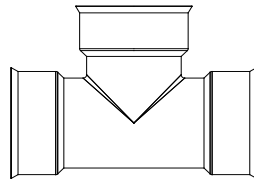

SIZE-ON-SIZE OR REDUCING TEE

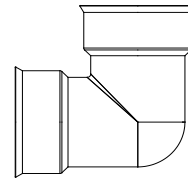

90-DEG BEND

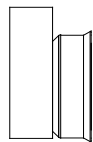

SPIGOT-BELL REDUCER

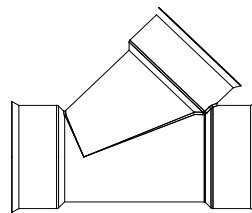

SIZE-ON-SIZE OR REDUCING
45-DEG WYE

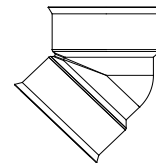

45-DEG BEND

Refer to the Product Catalog for a complete listing of available fittings. Availability may vary for each fitting type based on diameter or joint performance.

Injection Molded Fittings Joint System

(Joint configuration & availability subject to change without notice. Product detail may differ slightly from actual product appearance.)

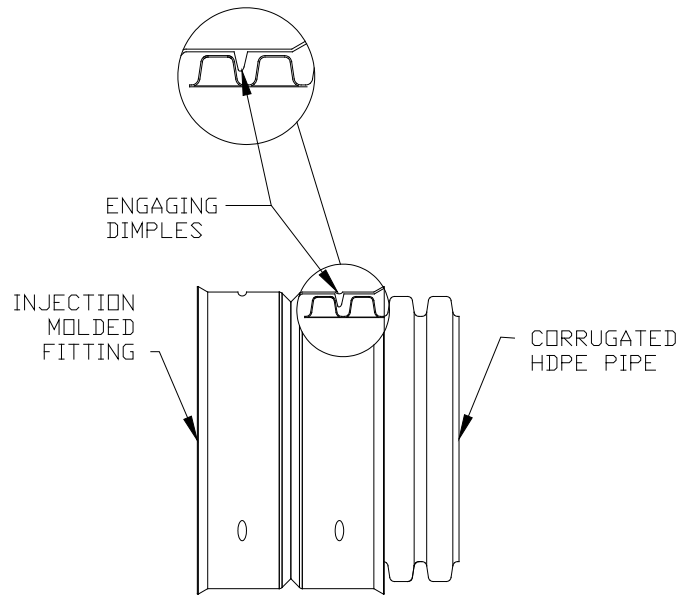

SOIL-TIGHT (ST)
JOINT CONFIGURATION

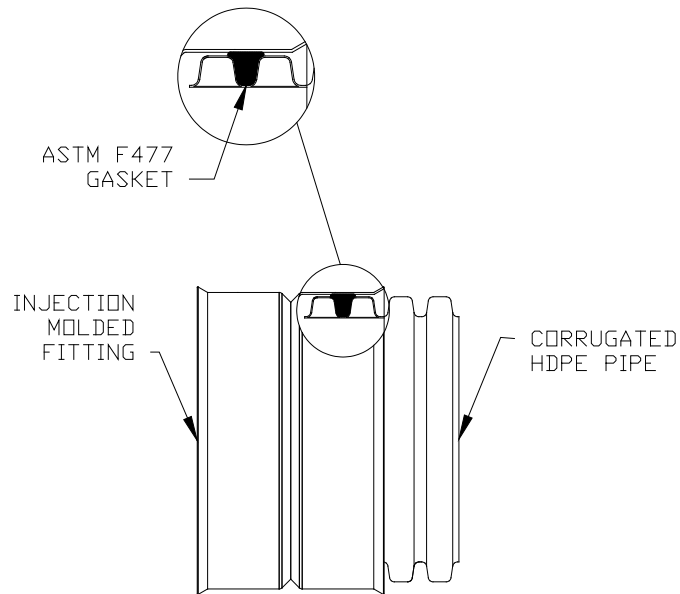

WATERTIGHT (WT)
JOINT CONFIGURATION

MAR MAC® POLYSEAL REPAIR COUPLER SPECIFICATION

Scope

The Mar Mac Polyseal Repair Coupler is a connection for 8- through 60-inch (200 to 1500 mm) ADS pipe.

Material Properties

The Mar Mac PolySeal Repair Coupler, as manufactured by Mar Mac® Construction Products, Inc. and distributed by ADS, Inc., consists of a mastic adhesive base layer, a woven polypropylene mesh middle layer, and a cross-laminated polyethylene film outer layer, with mechanical compression bands integrated into the coupler.

Installation

Installation shall be in accordance with Mar Mac Construction Products, Inc. recommended installation instructions. Polyseal Repair Coupler, in conjunction with corrugated HDPE pipe, is considered a soil-tight connection unless otherwise approved by local governing body.

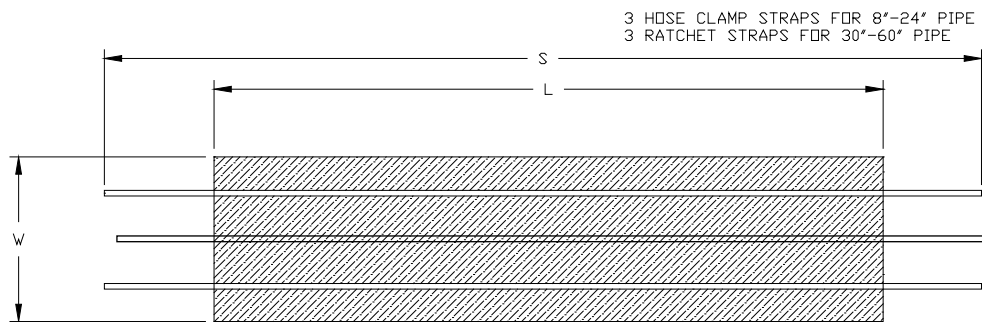

Nominal Pipe Diameter*, in. (mm)	Strap Length (S) in. (mm)	Standard		Double Wide	
		Length (L) in. (mm)	Width (W) in. (mm)	Length (L) in. (mm)	Width (W) in. (mm)
8 (200)	40 (1016)	36 (914)	9 (229)	36 (914)	12 (305)
10 (250)	45 (1143)	45 (1067)	9 (229)	45 (1067)	12 (305)
12 (300)	54 (1372)	54 (1372)	9 (229)	54 (1372)	12 (305)
15 (375)	67 (1702)	64 (1626)	9 (229)	64 (1626)	16 (406)
18 (450)	79 (2007)	76 (1930)	12 (305)	76 (1930)	16 (406)
24 (600)	102 (2591)	101 (2565)	12 (305)	101 (2565)	20 (508)
30 (750)	122 (3099)	122 (3099)	16 (406)	122 (3099)	28 (711)
36 (900)	145 (3683)	142 (3607)	20 (508)	142 (3607)	28 (711)
42 (1050)	162 (4115)	162 (4155)	20 (508)	162 (4115)	28 (711)
48 (1200)	183 (4648)	183 (4648)	20 (508)	183 (4648)	32 (813)
60 (1500)	222 (5639)	222 (5639)	28 (711)	222 (5639)	42 (1067)

*4", 6" and 54" standard couplers may be available by special order. Contact an ADS representative.

PVC COUPLING SPECIFICATION

Scope

This specification describes the PVC Coupling for use in joint repair of surface drainage applications.

Requirements

PVC couplings are manufactured from SDR 35 Sewer PVC pipe stock.

All PVC couplings shall be manufactured to meet the mechanical property requirement for fabricated fittings as described in ASTM D3034 and F679.

Joint Performance

Joints created by the PVC coupler shall be manufactured with a bell coupling sized to accept dual wall corrugated HDPE pipe with a rubber gasket. A joint lubricant supplied by the manufacturer shall be used on the gasket and bell during assembly. Gaskets supplied with the coupling shall meet the requirements of ASTM F477.

The joint shall be watertight according to the laboratory requirements of ASTM D3212. Joints shall remain watertight when subjected to a 1.5 degree axial misalignment.

Material Properties

PVC coupling shall be manufactured from SDR 35 Sewer PVC pipe stock meeting ASTM D3034 for 4- through 15-inch diameters or F679 for 18- through 24-inch diameters.

Installation

Installation shall be in accordance with ADS pipe installation instructions using typical flexible pipe installation methods. Contact your local ADS representative or visit www.adspipe.com for latest installation instructions.

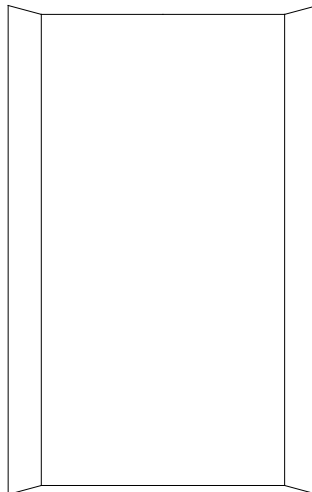

WATERSTOP™ GASKET SPECIFICATION

Scope

This specification describes the WaterStop gasket available in 12- to 60- inch (300 to 1500 mm) diameters and used for a field installed seal that prevents water infiltration or exfiltration at manhole connections.

Material Properties

The WaterStop gasket is made of a polyisoprene compound which meets the physical property requirements of ASTM C923.

Installation

Installation shall be in accordance with ADS recommended installation instructions. Contact your local ADS representative or visit www.adspipe.com for a copy of the latest installation guidelines.

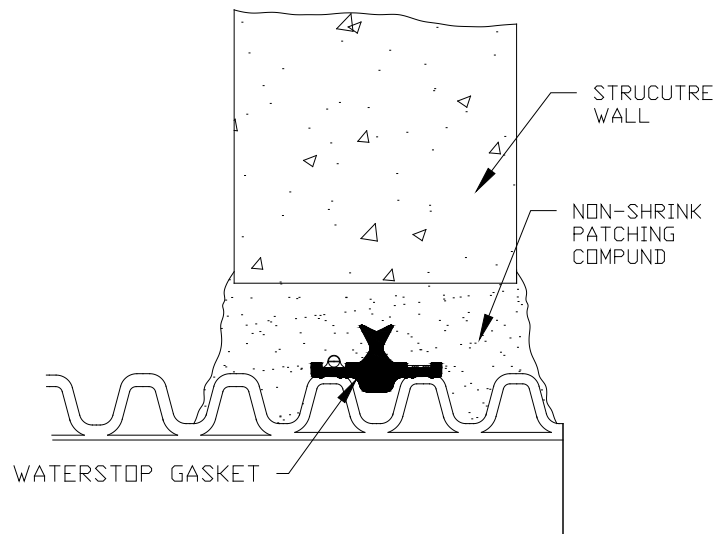

Nominal Pipe I.D., in. (mm)	Recommended Minimum Hole Diameter, in. (mm)	Minimum Distance Pipe Invert to Structure Invert, in (mm)
12 (300)	19.5 (495)	3.7 (4)
15 (375)	23 (584)	4 (102)
18 (450)	26.5 (673)	4.2 (107)
24 (600)	33.3 (846)	4.5 (114)
30 (750)	40.5 (1029)	5.2 (132)
36 (900)	47 (1194)	5.5 (140)
42 (1050)	53 (1346)	5.7 (145)
48 (1200)	59 (1499)	5.7 (145)
54 (1375)	65 (1651)	6.4 (163)
60 (1500)	72 (1829)	6.4 (163)

* Check with Sales Representative for availability

FLARED END SECTION SPECIFICATION

Scope

This specification describes 12- through 36-inch (300 to 900mm) Flared End Sections for use in culvert and drainage outlet applications.

Requirements

The Flared End Section shall be high density polyethylene meeting ASTM D3350 minimum cell classification 213320C; contact manufacturer for additional cell classification information. When provided, the metal threaded fastening rod shall be stainless steel.

Installation

Installation shall be in accordance with ADS installation instructions and with those issued by state or local authorities. Contact your local ADS representative or visit www.adspipe.com for the latest installation instructions.

Build America, Buy America (BABA)

The ADS Flared End Section complies with the requirements in the Build America, Buy America (BABA) Act.

	PIPE DIAMETER, in (mm)			
Diameter	12	15	18	24
in (mm)	(300)	(375)	(450)	(600)
A	6.5	6.5	7.5	7.5
in (mm)	(165)	(165)	(191)	(191)
B (max)	10.0	10.0	15.0	18.0
in (mm)	(254)	(254)	(381)	(475)
H	6.5	6.5	6.5	6.5
in (mm)	(165)	(165)	(165)	(165)
L	25.0	25.0	32.0	36.0
in (mm)	(635)	(635)	(813)	(914)
W	29.0	29.0	35.0	45.0
in (mm)	(737)	(737)	(889)	(1143)

*Product detail may differ slightly from actual product appearance

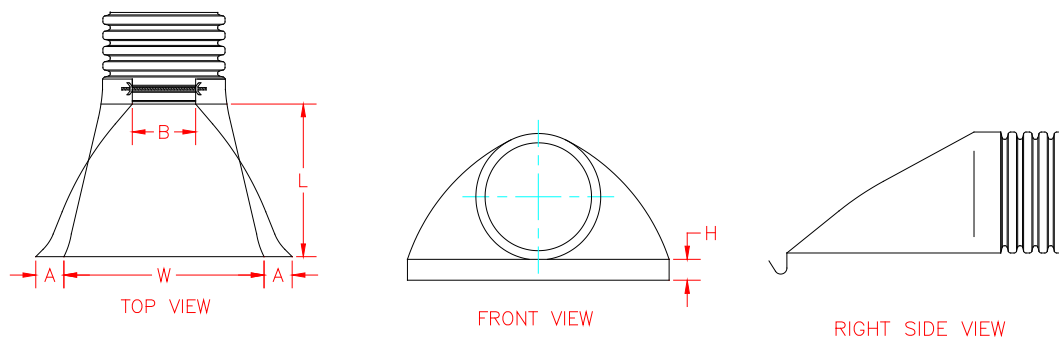

MITERED END SECTION SPECIFICATION

Scope

This specification describes 12- through 60-inch (300 to 1500mm) Mitered End Sections for use in culvert and drainage outlet applications.

Requirements

The invert of the pipe and the end section shall be at the same elevation. Mitered End Section shall be high-density polyethylene conforming with the minimum requirements of cell classification 335400C as defined and described in ASTM D3350 except that carbon black content should not exceed 4%. The 12- through 60-inch (300 to 1500mm) pipe material shall comply with the notched constant ligament-stress (NCLS) test as specified in Sections 9.5 and 5.1 of AASHTO M294 and ASTM F2306 respectively.

Build America, Buy America (BABA)

Mitered End Section, manufactured in accordance with AASHTO M294 or ASTM F2306, complies with the requirements in the Build America, Buy America (BABA) Act.

Installation

Installation shall be in accordance with ASTM D2321 and ADS installation guidelines. Contact your local ADS representative or visit our website at www.adspipe.com for a copy of the installation guidelines.

Pipe Dia. in (mm)	Slope x:1		Slope 2:1		Slope 3:1		Slope 4:1		Slope 6:1	
	C* in (mm)	D in (mm)	B in (mm)	OAL in (mm)	B in (mm)	OAL in (mm)	B in (mm)	OAL in (mm)	B in (mm)	OAL in (mm)
12 (300)	3 (76)	3 (76)	12 (305)	20 (508)	18 (457)	26 (660)	24 (610)	32 (813)	36 (914)	44 (1118)
15 (375)	4 (102)	4 (102)	14.8 (376)	24.5 (622)	22 (559)	31.9 (810)	29.4 (747)	39.1 (993)	41.6 (1057)	51.4 (1306)
18 (450)	4.2 (107)	4 (102)	21 (533)	33 (838)	30 (762)	42 (1067)	39 (991)	51 (1295)	60 (1524)	72 (1829)
24 (600)	6 (152)	6 (152)	24 (610)	40 (1016)	36 (914)	52 (1321)	48 (1219)	64 (1626)	72 (1829)	88 (2235)
30 (750)	6 (152)	6 (152)	36 (914)	52 (1321)	56 (1422)	72 (1829)	72 (1829)	88 (2235)	108 (2743)	124 (3150)
36 (900)	6.9 (175)	6 (152)	48.1 (1222)	64.6 (1641)	73.9 (1877)	92.3 (2344)	96.9 (2461)	115.4 (2931)		
42 (1050)	5.2 (132)	6 (152)	64.4 (1636)	82 (2083)	93.6 (2377)	111.3 (2827)	122.9 (3122)	140.5 (3569)		
48 (1200)	5.4 (137)	6 (152)	76.1 (1933)	93.6 (2377)	111.2 (2825)	128.7 (3269)	146.4 (3719)	163.9 (4163)		
54 (1375)	5.4 (137)	6 (152)	85.1 (2162)	108.4 (2753)						
60 (1500)	3.6 (91)	6 (152)	100.6 (2555)	123.9 (3147)						

*The "C" dimension varies slightly for some diameters depending on the slope

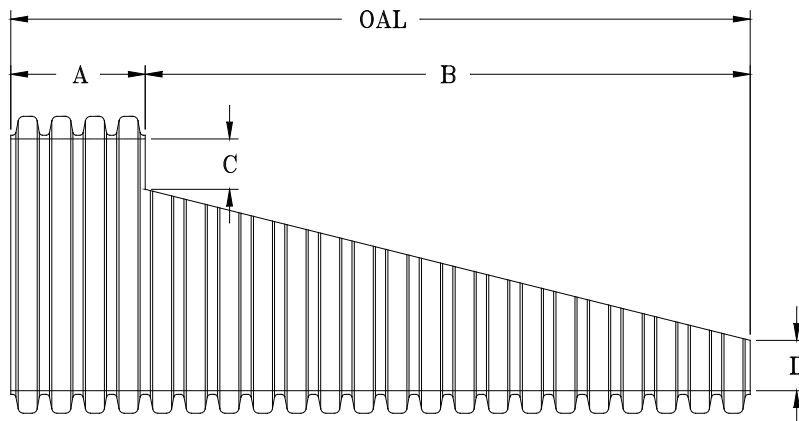

Note: ADS recommends that the product be installed with a concrete collar/edge to support and close corrugations per DOT specifications. The Channel at the bottom of the taper must be shaped to prevent toe lift by the inlet water flow.

TAYLOR END PLUG PRODUCT SPECIFICATION

Scope

This specification describes 4- through 60-inch (100 to 1500mm) Taylor End Plugs, as manufactured by Taylor Made Plastics, Inc., for use in temporary storm drainage, gravity-flow applications.

Requirements

Taylor End Plug shall be made of polyethylene with a gasket sized in order to fit in the spigot end of corrugated polyethylene pipe.

Joint Performance

The end plug shall provide a soil-tight joint per ASTM F2306.

Installation

Installation shall be in accordance with Taylor Made Plastics, Inc installation instructions. End plugs are not intended for permanent use or vertical applications.

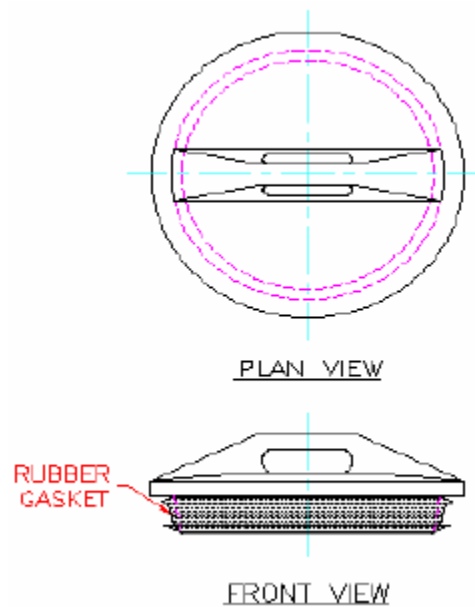

STORM WATER QUALITY UNIT PRODUCT SPECIFICATION

Scope

This specification describes 36- through 60-inch (900 to 1500 mm) Storm Water Quality Units for use in on-site point source storm water treatment applications.

Requirements

Storm Water Quality Units shall have a smooth interior and annular exterior corrugations meeting the requirements of ASTM F2737.

The unit shall have at least three containment zones, each zone separated from the next by use of a weir or baffle plate

Weir and baffle plates shall be welded at all interfaces between the plate and water quality unit. First weir plate shall incorporate a saw tooth design and shall be reinforced with stiffeners positioned horizontally on the downstream side of the plate to be retained.

Storm Water Quality Units shall provide adequate clean-out and inspection access.

Joint Performance

Connections for the bypass line and the unit shall utilize the same joint quality as specified for the main storm sewer pipe. Couplers for the bypass line may be either split couplers, in-line bell couplers, snap couplers, bell-bell couplers, or welded bell couplers.

Material Properties

Material for pipe and fittings used to produce Storm Water Quality Units shall be high density polyethylene conforming with the minimum requirements of cell classification 424420C for 4- through 10-inch (100 to 250 mm) diameters, and 435400C for 12- through 60-inch (300 to 1500mm) diameters as defined and described in the latest version of ASTM D3350. The pipe material shall be evaluated using the notched constant ligament-stress (NCLS) test as specified in Sections 9.5 and 5.1 of AASHTO M294 and ASTM F2306, respectively. All smooth baffle and weir plates shall be high density polyethylene.

Build America, Buy America (BABA)

Storm Water Quality Unit, manufactured in accordance with AASHTO M294 or ASTM F2306, complies with the requirements in the Build America, Buy America (BABA) Act.

Installation

Installation shall be in accordance with the ADS recommended installation guidelines, utilizing a class I (ASTM D2321) structural backfill material or flowable fill (CLSM –Controlled Low Strength Material). Contact your local ADS representative or visit www.adspipe.com for the latest installation instructions.

Performance

Water Quality Units shall remove a minimum of 80% of the first flush total suspended solids (TSS) based on flow rates and corresponding sieve sizes shown in Table 1. Water Quality units shall be installed “offline” to prevent re-suspension of solids in high flow situations. Offline installation shall be constructed utilizing an ADS By-Pass structure. Flow through the unit shall be controlled by an orifice fabricated on the outlet end of the structure.

Table 1: Storm Water Quality Unit Dimensions and Specifications (based on mathematical calculations)

I.D. in (mm)	Inlet Size in (mm)	Outlet Size in (mm)	Length ft (m)	Treated Flow Rate cfs (cms)	Sediment Volume ft ³ (m ³)	Floatables Volume ft ³ (m ³)	Sieve Size
36 (900)	10 (254)	10 (254)	20 (6.1)	1.50 (0.04)	65 (1.8)	30 (0.8)	140
	10 (254)	10 (254)	40 (12.2)	2.38 (0.07)	137 (3.9)	63 (1.8)	140
	10 (254)	10 (254)	20 (6.1)	0.70 (0.002)	65 (1.8)	30 (0.8)	200
	10 (254)	10 (254)	40 (12.2)	1.60 (0.05)	137 (3.9)	63 (1.8)	200
42 (1050)	12 (305)	12 (305)	20 (6.1)	1.73 (0.05)	83 (2.4)	38 (1.1)	140
	12 (305)	12 (305)	40 (12.2)	3.66 (0.10)	175 (5.0)	81 (2.3)	140
	12 (305)	12 (305)	20 (6.1)	0.86 (0.02)	83 (2.4)	38 (1.1)	200
	12 (305)	12 (305)	40 (12.2)	1.83 (0.05)	175 (5.0)	81 (2.3)	200
48 (1200)	12 (305)	12 (305)	20 (6.1)	2.26 (0.06)	116 (3.3)	55 (1.6)	140
	12 (305)	12 (305)	40 (12.2)	3.94 (0.11)	245 (6.9)	115 (3.3)	140
	12 (305)	12 (305)	20 (6.1)	1.13 (0.03)	116 (3.3)	55 (1.6)	200
	12 (305)	12 (305)	40 (12.2)	2.39 (0.07)	245 (6.9)	115 (3.3)	200
60 (1500)	15 (381)	15 (381)	20 (6.1)	2.95 (0.08)	183 (5.2)	87 (2.5)	140
	15 (381)	15 (381)	40 (12.2)	6.23 (0.17)	385 (10.9)	184 (5.2)	140
	15 (381)	15 (381)	20 (6.1)	1.47 (0.04)	183 (5.2)	87 (2.5)	200
	15 (381)	15 (381)	40 (12.2)	3.12 (0.09)	385 (10.9)	184 (5.2)	200

STORM WATER QUALITY UNIT

(Unit configuration & availability subject to change without notice. Product detail may differ slightly from actual product appearance.)

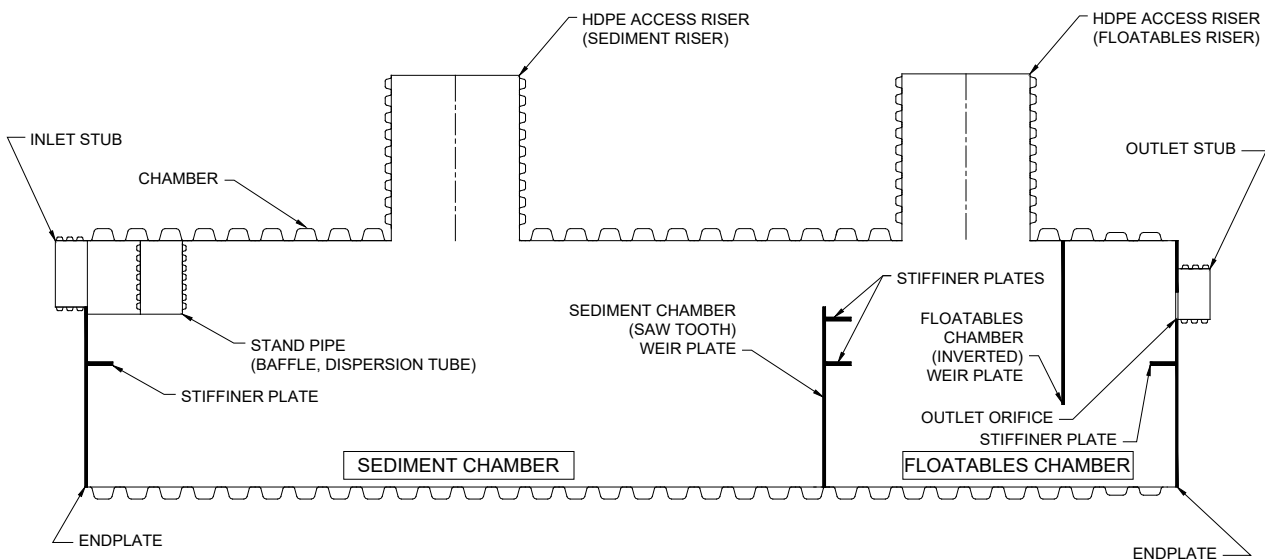

BIODIFFUSER™ SEPTIC LEACHING CHAMBER SPECIFICATION

Scope

This specification describes the Standard, High-Capacity, Bio 2, and Bio 3 BioDiffuser units for use in onsite wastewater disposal applications.

Chamber Requirements

BioDiffuser chambers are manufactured from high-density polyethylene with an open bottom, solid top and louvered sidewalls. Sidewall louvers shall be designed to minimize soil intrusion.

Chamber shall meet the load rating of H-10 (16,000 lb per axle) with a minimum of 12-inches (300 mm) of cover when tested in accordance with IAPMO PS 63 and installed in accordance with ADS installation procedures.

The 16" (400 mm) high capacity chamber is also available in H-20 (32,000 lb per axle) rated version. To order the H-20 ARC chamber model, please contact an ADS representative.

Chamber Connection

Each chamber shall interlock with the beginning of the next chamber by overlapping post and dome while engaging overlapping flanges.

Material Properties

Each chamber shall be manufactured from high density polyethylene resin as defined and described in IAPMO PS 63.

Installation

Installation shall be in accordance with ADS installation procedures and those issued by the local health department regulations.

Chamber Dimensions

	16" High Capacity Model No. 1600BD
Length (A) in (mm)	76" (1930)
Repeat Length (E) in (mm)	75" (1905)
Side Wall Height (B) in (mm)	11.2" (285)
Overall Height (C) in (mm)	16" (406)
Overall Width (D) in (mm)	34" (864)
Capacity ft ³ (m ³)	13.6 cu ft (0.39)
Weight lbs (kg)	35 (15.9)
Units/Pallet	45
Truck Load Quantity*	18 pallets

*End Caps may reduce truck load pallet quantity.

(Unit configuration & availability subject to change without notice. Product detail may differ slightly from actual product appearance.)

16" (400 mm) High Capacity Chamber

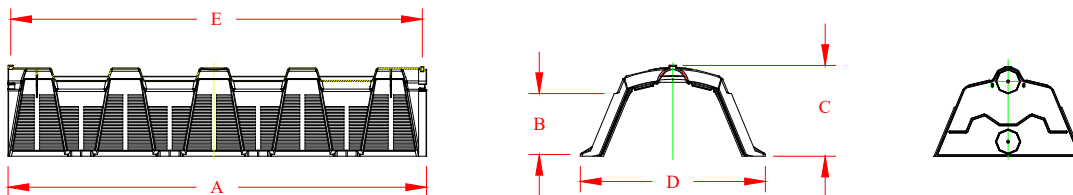

ARC™ SEPTIC LEACHING CHAMBER SPECIFICATIONS

Scope

This specification describes the Arc chamber units for use in onsite wastewater disposal applications.

Chamber Requirements

Arc chambers are manufactured from high-density polyethylene with an open bottom, solid top and louvered sidewalls. Sidewall louvers shall be designed to minimize soil intrusion.

Chamber shall meet the load rating of H-10 (16,000 lb per axle) with a minimum of 12 inches (300 mm) of cover when tested in accordance with IAPMO PS 63 and installed in accordance with manufacturers installation procedures.

Chamber Connection

Each chamber shall interlock with an integral articulating joint. Articulating joints shall have a free range of horizontal rotation of 20 degrees, with a maximum of 10 degrees in either direction. Articulating joint shall be constructed by placing the dome with engaging knuckle of the incoming chamber over the post end of the previously-installed chamber.

Material Properties

Each chamber shall be manufactured from high-density polyethylene as defined and described in IAPMO PS 63.

Installation

Installation shall be in accordance with ADS installation procedures as well as all state and local health department regulations.

	Arc 18	Arc 24	Arc 36	Arc 36 HC	Arc 36 LP
Length (A) in (mm)	67 (1701)	67 (1701)	63 (1600)	63 (1600)	63 (1600)
Repeat Length (E) in (mm)	60 (1524)	60 (1524)	60 (1524)	60 (1524)	60 (1524)
Side Wall Height (B) in (mm)	7.7 (196)	7.5 (191)	7.13 (181)	10.75 (273)	5.5 (140)
Overall Height (C) in (mm)	12 (305)	12 (305)	13 (330)	16 (406)	8 (203)
Overall Width (D) in (mm)	16 (406)	22.5 (572)	34 (864)	34 (864)	34 (864)
Capacity ft ³ (m ³)	3.42 (0.09)	5.02 (0.14)	8 (0.22)	10.7 (0.30)	5.80 (0.16)
Pallet Quantity	135 chambers	120 chambers	70 chambers	60 chambers	60 chambers
Truck Load Quantity*	16 pallets	16 Pallets	24 Pallets	24 Pallets	24 Pallets

*End Caps may reduce truck load pallet quantity.

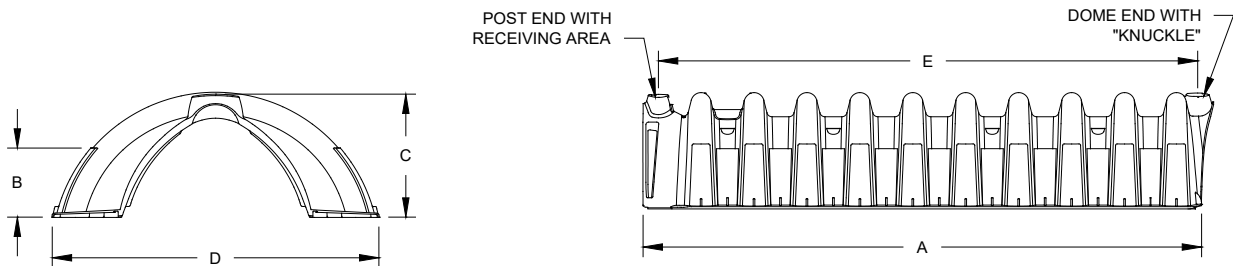

SUMP PUMP WELL SPECIFICATION

Scope

This specification describes the sump pump well for use in residential drainage applications.

Requirements

The sump pump well shall be available in both 14-gallon (53 liters) and 19-gallon (72 liters) sizes. Each well shall have three pre-formed inlet collars sized to fit 4-inch (100mm) corrugated polyethylene drainage lines. Each well shall have a molded side panel designed to accept the outside basement perimeter line at any elevation along the well wall. Both wells shall have a twist-locking lid.

Material Properties

Sump pump well material shall be high density polyethylene.

Installation

Installation shall be in accordance with ADS installation instructions and those issued by regional, state, or local agencies.

	A	B	C	D	E	F	G	H	I	J
14-gallon	12"	8"	14.25"	4.75"	20.38"	18.13"	24"	20.88"	18.38"	20.5"
53 liters	305mm	203mm	362mm	121mm	518mm	460mm	610mm	530mm	467mm	521mm
19-gallon	12"	13"	14.25"	4.75"	20.38"	24"	31.75"	20.88"	18.38"	20.5"
72 liters	305mm	330mm	362mm	121mm	518mm	610mm	806mm	530mm	467mm	521mm

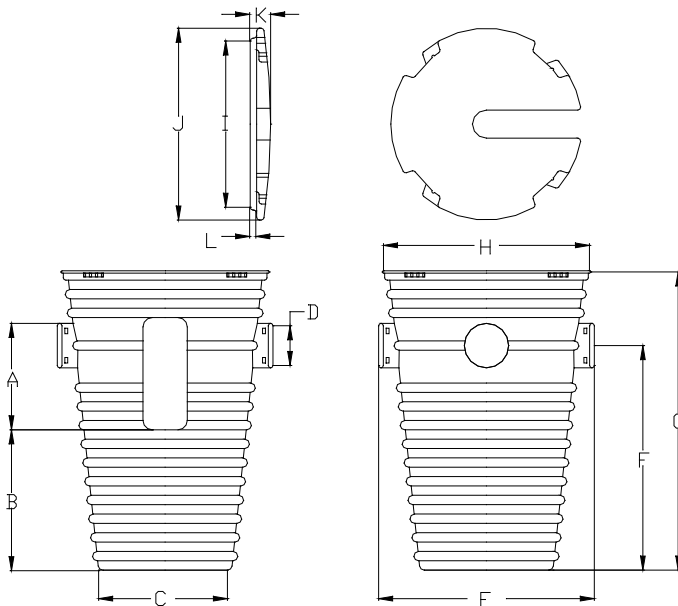

RADON DUAL PURPOSE VENTED SUMP SPECIFICATION

Scope

This specification describes the Radon Dual Purpose Vented Sump System for use in residential drainage and ventilation of toxic or noxious gas applications.

Requirements

The Radon Dual Purpose Vented Sump shall be available in 14-gallon (53 liter) capacity. The sump well shall have three pre-formed inlet collars sized to fit 4-inch (100 mm) corrugated polyethylene drainage lines. Each well shall have a molded side panel designed to accept the outside basement perimeter line at any elevation along the well wall. The lid shall be pre-drilled to accept 1¼-inch (32mm), 1½-inch (38mm), 2 inch (50mm), or 3-inch (75mm) vent and discharge pipes. Rubber o-rings for these pipes, as well as rubber pump wire plug shall be included with the lid kit.

Material Properties

Radon Dual Purpose Vented Sump shall be high density polyethylene.

Installation

Installation shall be in accordance with ADS installation instructions and those issued by regional, state, or local agencies.

	A	B	C	D	E	F	G	H
14-gallon	12"	8"	14.25"	4.75"	20.38"	18.13"	24"	20.06"
53 liter	305mm	203mm	362mm	121mm	518mm	460mm	610mm	510mm

Items Included With Lid Kit

Qty.

- 1 Gasket for 4" Sch 40 or SDF PVC inlet line
- 1 Gasket for 2" and 3" Sch 40 vent pipe
- 1 Gaskets for 2", 1 ½", and 1" Sch 40 PVC pump discharge pipes
- 1 Electrical Cord Stopper
- 1 1" Adhesive Foam Tape

Items Needed For Lid Kit (Sold Separately)

Qty.

- 4 Hex Head Lag Screws ¼" x 1 ½" (minimum)
- 4 Flat Washers ¼"
- 4 Concrete Floor Anchors

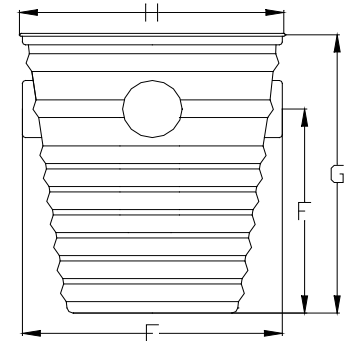
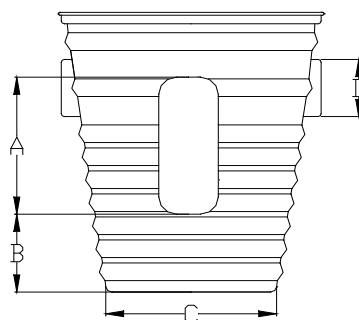
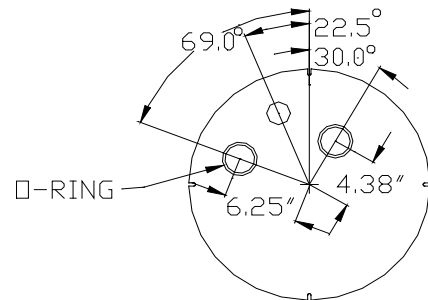

SEWAGE EJECTOR SUMP SPECIFICATION

Scope

This specification describes the Sewage Ejector Sump System for use in residential sewage applications.

Requirements

The Sewage Ejector Sump shall be available in 19-gallon (72 liter) capacity. The sump well shall have one pre-drilled inlet hole with an o-ring gasket adapter for standard 4-inch (100mm) SDR 35 sewer pipe or a PVC hub for standard 4-inch (100 mm) schedule 40 sewer pipe. Each well shall have three molded side panels designed to accept an extra inlet line at 90-degree increments around its circumference. The lid shall be pre-drilled to accept 1¼-inch (32 mm), 1½-inch (38 mm), 2-inch (50 mm) or 3-inch (75 mm) vent and discharge pipes. Rubber o-rings for these pipes, as well as rubber pump wire plug shall be included in the lid kit.

Material Properties

Sewage Ejector Sump shall be high-density polyethylene.

Installation

Installation shall be in accordance with ADS installation instructions and those issued by regional, state, or local agencies.

	A	B	C	D	E	F	G	H
19-gallon 72 liter	12" 305mm	13" 330mm	14.25" 362mm	4.75" 121mm	20.38" 518mm	24" 610mm	31.75" 806mm	20.06" 510mm

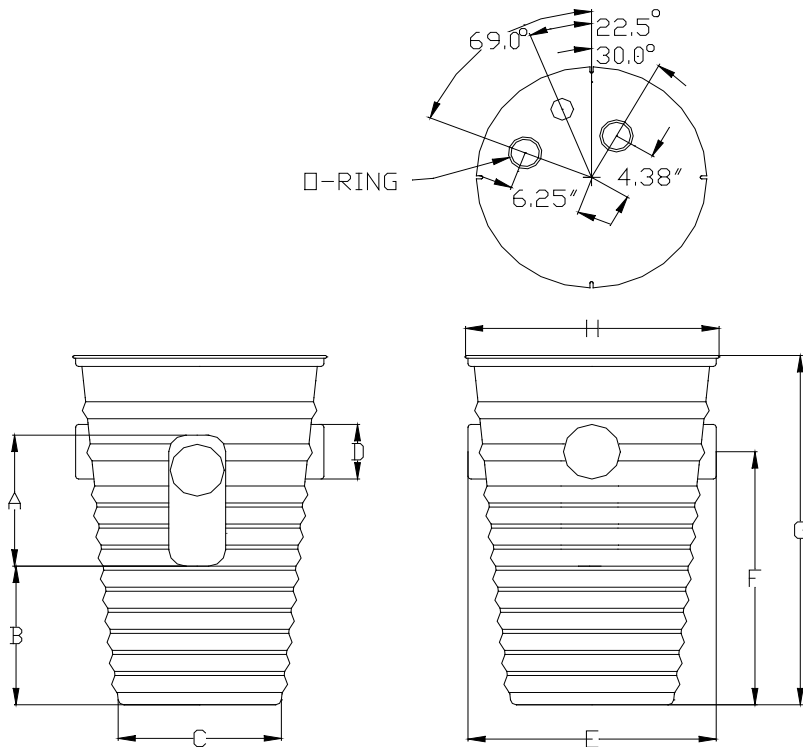

Items Included With Lid Kit

Qty.	
1	Gasket for 4" Sch 40 or SDR 35 PVC inlet line
1	Gasket for 2" and 3" Sch 40 PVC vent pipe
1	Gaskets for 2", 1 ½", and 1 ¼" Sch 40 PVC pump discharge pipes
1	Electrical Cord Stopper
1	1" Adhesive Foam Tape

Items Needed For Lid Kit (Sold Separately)

Qty.	
4	Hex Head Lag Screws ¼" x 1 ½" (minimum)
4	Flat Washers ¼"
4	Concrete Floor Anchors

FILTER SOCK SPECIFICATION

Scope

This specification describes 2- through 48-inch (50- to 1200 mm) SOCK synthetic wrap.

Filter Fabric Requirements

The SOCK shall meet the requirements of ASTM D6707.

ADS sock products as listed on this specification meet Ontario Provincial Standard Specification 1860, Material Specifications for Geotextiles, dated March 1998.

Filter Fabric Properties

Property	Test Method	Material
Material	-	Polyester
Fabric	-	Knitted
Permittivity (min.)	ASTM D4491	5.5 sec ⁻¹
Puncture Resistance (min.)	ASTM D6241	1000 N
AOS (max.)	ASTM D4751	0.600 mm 30 U.S. Sieve
FOS (max.)	CAN/CGSB-148.1, M10-94	450 microns
Mass (relaxed)	ASTM D3887	3.0-3.9 oz/yd ² 101.7-132.2 g/cm ²
Mass (applied minimum)		2.7-3.5 oz/yd ² 91.5-118.7 g/cm ²
Thickness (min.)	ASTM D4491	24.0 mils 609.6 microns
Permeability (K) (min.)	ASTM D4491	0.390 cm/sec
Burst Strength (min.)	ASTM D3786	760 kpa
Air Permeability (min.)	ASTM D737	700 ft ³ /ft ² /min 213 m ³ /m ² /min
Water Flow Rate (min.)	ASTM D4491 (2" constant head)	300 gal/min/ft ² 12,224 L/min/m ²
Yarn Denier	-	150
Specific Gravity	-	1.3
Melt Temperature	-	450° F 232° C

Structures



2-0 STRUCTURES

TABLE OF CONTENTS

- 2-1 Overview of Structural Considerations 2-2**
- 2-2 Introduction..... 2-3**
- 2-3 Design Criteria 2-4**
 - Pipe Section Properties 2-5
 - Material Properties..... 2-6
 - Installation Conditions and Soil Factors 2-8
 - Loads 2-12
- 2-4 Thermoplastic Pipe Design Procedure 2-17**
 - Load and Resistance Factors..... 2-17
 - Wall Thrust 2-18
 - Buckling 2-21
 - Compressive Strain 2-23
 - Bending Strain 2-22
 - Combined Strain 2-24
- 2-5 Research and Installations 2-26**

Figures

- 2-1 AASHTO H-25 and HS-25 Highway Load 2-12
- 2-2 Typical and Idealized Corrugation Profiles..... 2-19

Tables

- 2-1 General Section Properties for N-12[®], N-12 STIB, and N-12 WTIB Pipe 2-5
- 2-2 General Section Properties for HP Storm Pipe 2-5
- 2-3 General Section Properties for SaniTite[®] HP Pipe 2-6
- 2-4 General Section Properties for Singlewall Pipe 2-6
- 2-5 Mechanical Properties for Thermoplastic Pipe 2-7
- 2-6 Classes of Embedment and Backfill Materials 2-10
- 2-7 Secant Constrained Soil Modulus, Ms..... 2-11
- 2-8 Shape Factors, D_r 2-12
- 2-9 AASHTO Highway Loads Carried by Wheel Set 2-13
- 2-10 Live Load Data for AASHTO H-25, HS-25 and Cooper E-80 ... 2-14
- 2-11 Load Factors 2-18
- 2-12 Resistance Factors 2-18
- 2-13 Load Modifiers..... 2-18

BUYER/USER IS RESPONSIBLE FOR SERVICEABILITY OF THE PRODUCT IN ANY GIVEN APPLICATION. SELLER IS NOT RESPONSIBLE FOR INJURY OR DAMAGE RESULTING FROM IMPROPER INSTALLATION, NONCOMPLIANCE WITH THESE GUIDELINES FOR INSTALLATION OF PRODUCT, OR USE OUTSIDE THE GUIDELINES SET FORTH HEREIN.

2-1 OVERVIEW OF STRUCTURAL CONSIDERATIONS

All pipe, whether flexible or rigid, rely on the backfill structure to transfer loads into the bedding. Pipe must be installed as designed to perform as expected.

This section sets forth the design methodology for thermoplastic pipes, specifically, corrugated high density polyethylene and polypropylene pipe based on AASHTO LRFD Bridge Design Specifications Section 12: Buried Structures and Tunnel Liners (2008 Interim Revision). Section properties for both, corrugated polyethylene and corrugated polypropylene pipes are presented. Material properties, backfill criteria, and load conditions also factor into the procedure. The design procedure evaluates wall thrust, bending, buckling, and strain and establishes limits on each condition. The procedure yields conservative results and is applicable to all thermoplastic pipes. ADS is a manufacturer of both polyethylene and polypropylene products for a variety of applications. All pipe products with the exception of our HP, including HP Storm and SaniTite HP, are manufactured from high density polyethylene; our HP product lines are manufactured from polypropylene. When using this design procedure, the engineer shall specify both the product and material used in design assumptions.

Minimum and Maximum burial depths can vary greatly depending on the application, product, backfill material, and compaction level; please refer to Appendix A-5 in the *Installation* section for a listing of appropriate technical literature and standard details related to ADS products and applications. All technical literature listed in this chart is available on the ADS website or from your local ADS representative. For custom applications, contact ADS application engineering for a review of specific project needs.

Thermoplastic pipe performance has been heavily researched through the laboratory and the field. Much of this work documents the conservatism of this design procedure. Several of the research projects are briefly discussed at the end of this section. These and other materials are available through ADS.

2-2 INTRODUCTION

Pipe behavior can be broadly classified as flexible or rigid, depending on how it performs when installed. Flexible pipe must move, or deflect, to transfer the overburden load to the surrounding soil. ADS N-12, HP Storm, SaniTite, SaniTite HP and Singlewall pipes are all examples of flexible pipe. Flexible pipe, therefore, is not designed to carry overburden loads directly. Rigid pipe is commonly defined as a pipe that does not deflect more than 2% without structural distress, and as such, it must be designed to carry the majority of the load directly. Reinforced and non-reinforced concrete pipe are both examples of rigid pipe.

Both flexible and rigid pipe depend on proper backfill. In the case of flexible pipe, deflection allows loads to be transferred to and carried by the backfill. Rigid pipe transmits most of the load through the pipe wall into the bedding. In both cases, proper backfill is very important in allowing this load transfer to occur.

Many research projects have investigated the behavior of flexible pipe. Thermoplastic pipe performance has been investigated through use of actual field installations, post-installation inspections, load cell tests, and finite element computer analyses. Now, three decades after its introduction, the behavior of thermoplastic pipe, including corrugated polyethylene and corrugated polypropylene pipes, has probably been analyzed more than any other conventional drainage pipe.

The information in subsequent areas of this section provides a step-by-step guide for the structural design of nonpressure corrugated polyethylene and polypropylene pipe. The methodology is based on the AASHTO design procedure, and has been proven through test installations and actual projects to be highly conservative. More discussion on actual installations is included in Section 2-5.

2-3 DESIGN CRITERIA

Design of thermoplastic pipe requires an understanding of pipe section properties, material properties, installation conditions, and the loading situation. All of these elements define the behavior of the pipe in some respect. This section describes the criteria that enter into the design procedure presented in Section 2-4.

PIPE SECTION PROPERTIES

As in the design of other structural components, the shape of the pipe profile helps determine how it will perform in the pipe/soil structure. Pipe properties include the moment of inertia of the wall profile (I), distance from the inside diameter to the neutral axis (c), and the section area of a longitudinal section (A_s). Pipe stiffness (PS) is a measure of the flexibility of a prescribed length of pipe and is measured in the laboratory by gauging the force required to deflect the pipe 5% of its inside diameter. Pipe stiffness is primarily a quality check not used directly in the design procedure and should not be interpreted to be a limiting pipe property. General properties of N-12, N-12 STIB, and N-12 WTIB are shown in Table 2-1, HP Storm in Table 2-2, SaniTite HP in Table 2-3, and Singlewall pipes are shown in Table 2-4. In order to complete design calculations listed in this structures section, general profile properties in conjunction with detailed section properties are necessary. Detailed section properties by product type and by diameter are found in ADS Product Notes 2.01 thru 2.05; please contact an ADS representative for this information.

Table 2-1
General Section Properties for N-12, N-12 ST IB, and N-12 WT IB Pipe

Nominal Pipe Diameter		Outside Diameter, OD		Pipe Stiffness, PS	
in	mm	in	mm	p _{ii}	kPa
4	100	4.8	121	50	340
6	150	6.9	175	50	340
8	200	9.1	231	50	340
10	250	11.4	290	50	340
12	300	14.5	368	50	345
15	375	18.0	457	42	290
18	450	22.0	559	40	275
24	600	28.0	711	34	235
30	750	36.0	914	28	195
36	900	42.0	1067	22	150
42	1050	48.0	1219	20	140
48	1200	54.0	1372	18	125
54	1350	61.0	1549	16	110
60	1500	67.0	1702	14	97

Table 2-2
General Section Properties for HP Storm Pipe

Nominal Pipe Diameter		Outside Diameter, OD		Pipe Stiffness, PS	
in	mm	in	mm	P _{ii}	kPa
12	300	14.5	368	75	520
15	375	17.7	450	60	411
18	450	21.4	544	56	385
24	600	28.0	711	50	343
30	750	35.5	902	46	320
36	900	41.5	1054	40	275
42	1050	47.4	1204	35	241
48	1200	54.1	1374	35	241
60	1500	67.1	1704	30	207

Table 2-3
General Section Properties for SaniTite HP Sanitary Pipe

Profile Type	Nominal Pipe Diameter		Outside Diameter, OD		Pipe Stiffness, PS	
	in	mm	in	mm	pil	kPa
Dual Wall	12	300	14.5	368	46	320
	15	375	17.6	447	46	320
	18	450	21.2	538	46	320
	24	600	28.0	711	46	320
	30	750	35.5	902	46	320
Triple Wall	30	750	35.5	902	46	320
	36	900	41.5	1054	46	320
	42	1050	47.4	1199	46	320
	48	1200	54.1	1374	46	320
	60	1500	67.1	1705	46	320

* OD values listed above are NOT for manhole connector sizing. See ADS Standard Detail 205A-F for the recommended manhole connector based on product and diameter.

Table 2-4
General Section Properties for Singlewall Pipe

Nominal Pipe Diameter		Outside Diameter, OD		Pipe Stiffness, PS	
in.	mm.	in.	mm	pil	kPa
3	75	3.6	91	35	240
4	100	4.6	117	35	240
6	150	7.0	178	35	240
8	200	9.5	241	35	240
10	250	12.0	305	35	240
12	300	14.5	368	50	340
15	375	18.0	457	42	290
18	450	22.0	559	40	275
24	600	28.0	711	34	235

Thermoplastic pipe products made by other manufacturers may have slightly different section properties depending on their design. Data for those products should be obtained from the respective manufacturer for use in this design procedure.

MATERIAL PROPERTIES

Behavior of viscoelastic materials differs from elastic materials like steel. When polyethylene and polypropylene are subjected to a constant force, the stress/strain curve that results gives the impression that the material loses strength with time. Tests that describe perfectly the behavior of elastic materials can, and in this case do, provide misleading results when used on viscoelastic materials.

Tests show that polyethylene and polypropylene do not weaken over time. The same stress/strain curve for the material can be duplicated repeatedly. What remains unaccounted for in the test is stress relaxation, which is a property unique to viscoelastics. Stress relaxation is decay in stress under a constant strain. In other words, a pipe that is held in a deflected position will initially experience relatively high stress levels that then quickly subside. Additional deflection causes a similar response: stress levels increase, and then soon decrease. This phenomenon has been documented in the laboratories at the University of Massachusetts. Tests there showed that when the pipe was held in a deflected position, the apparent modulus decreased. When deflection was increased, the pipe responded with a much higher modulus. (Additional information regarding this research is located in Section 2-5.)

Accounting for the time-dependent behavior in the design of thermoplastic pipe can become cumbersome. The procedure described in Section 2-5 explains how and when to use short term or long term material properties. See table 2-5 for materials properties list of polyethylene and polypropylene.

(Note: The tensile strength is used in some design computations although the predominant wall forces are compressive. Tests to determine the maximum compressive strength of polyethylene and polypropylene have to date been inconclusive because of a lack of a definite failure point or limit. However, the *ASCE Structural Plastics Design Manual* states "A general rule is that compressive strength of plastics is greater than tensile strength." Use of the tensile strength in design in lieu of the more appropriate compressive strength will yield conservative results. (*ASCE Manuals and Reports on Engineering Practice No. 63, ASCE: NY, NY, 1984, p. 163.*))

Table 2-5
Mechanical Properties for Thermoplastic Pipe¹

Product	Material	Allowable Strain, %	Initial		75-Year	
			F _u psi (MPA)	E psi (MPA)	F _u psi (MPA)	E psi (MPA)
N-12 ST IB, WT IB, Plain End, SaniTite, Low Head	Polyethylene	5	3000 (20.7)	110000 (758)	900 (6.21)	21000 (144)
N-12 HP Storm and SaniTite HP Sanitary	Polypropylene	4	3500 (24.1)	175000 (1206)	1000 (6.89)	28000 (193)

INSTALLATION CONDITIONS AND SOIL FACTORS

The structural performance of pipe depends on the interaction between the embedment, or backfill envelope, and the pipe, and is commonly referred to as pipe/soil interaction. The backfill envelope must provide structural and drainage characteristics appropriate for the application. Structural considerations of the backfill include the type of material and compaction level, dimensions of the backfill envelope, and native soil conditions. The information presented here is, with few exceptions, consistent with requirements established in ASTM D2321 "*Standard Practice for Underground Installation of Thermoplastic Pipe for Sewers and Other Gravity-Flow Applications.*" Additional information regarding dimensions of the backfill envelope and native soil considerations are discussed in more detail in the *Installation* section (Section 5) of the Drainage Handbook.

The type of material (sand, gravel, clay, etc.) and compaction level (standard Proctor density) determine overall strength of the backfill. As a general rule, material particles that are relatively large and angular require less compaction than particles that are smaller and less angular to produce structures having equal strength.

The strength of the backfill can be described using different parameters. One way is by describing it in terms of the modulus of soil reaction (E'), which is an empirical value developed by the Bureau of Reclamation to calculate deflection. Another parameter used to describe backfill strength is the secant constrained soil modulus (M_s). Although this property can be measured in the laboratory, values appropriate for design are shown in Table 2-7. This value must be used in the following calculations. While E' and M_s do have similar units, they are not considered interchangeable.

The native soil and other locally available materials may be considered for backfill. If they meet the criteria of Table 2-6 and Table 2-7, they may be acceptable materials and should be considered to minimize material and hauling costs. When in doubt about the appropriate material to use in an installation, consult an ADS engineer.

Mechanical compaction is not always necessary; some backfill materials can be dumped and others can meet minimum compaction criteria simply by being walked in around the pipe. On the other hand, mechanical compaction can make placement of some backfill materials much faster. Additional information regarding the types of mechanical compactors available and the soil types with which they work best is located in the *Installation* section (Section 5).

Another backfill material that has gained in application over the past few years is flowable fill. This material is similar to a very low strength concrete. It is poured around the pipe and hardens to form a solid backfill structure. The final cured strength of this material is highly dependent on mix design and should be determined by the design engineer. In order to take advantage of the strength of this material, the backfill strength of the surrounding native material must be adequate.

Where flowable fill is used, soft materials must be over-excavated and replaced with suitable bedding and side fill material. The major disadvantages of this material are that it can be very costly both in terms of material costs and installation time, and it will cause the pipe to float if precautions are not taken. Properly designed and installed, however, it can be used as an alternative to typical granular backfill. ADS engineers and some textbooks can provide additional guidance in the use of this material.

Table 2-6
Classes of Embedment and Backfill Materials

ASTM D2321 ^(A) Class	Description	Notation	ASTM D2487 Description	AASHTO M43 Notation	AASHTO M145 Notation	ASTM D2321 ^(A)							
						Percentage Passing Sieve Sizes				Atterberg Limits		Coefficients	
						1 ½ in. (40mm)	No. 4 (4.75mm)	3/8" (9.5mm)	No. 200 (0.075mm)	LL	PI	Cu	Cc
I ^(B)	Crushed rock, angular ^C	N/A	Angular crushed stone or rock, crushed gravel, crushed slag; large voids with little or no fines	5, 56, 57 ^(D) , 6, 67 ^(D)	N/A	100%	≤15%	<25%	<12%	Non Plastic		N/A	
II	Clean, coarse- grained soils	GW	Well-graded gravel, gravel-sand mixtures; little or no fines	5, 6	A1, A3	100%	<50% of "Coarse Fraction"	-	<5%	Non Plastic	>4	1 to 3	
		GP	Poorly-graded gravels, gravel-sand mixtures; little or no fines	56, 57, 67							<4	<1 or >3	
		SW	Well-graded sands, gravelly sands; little or no fines								>6	1 to 3	
		SP	Poorly-graded sands, gravelly sands; little or no fines								<6	<1 or >3	
	Coarse-Grained Soils, borderline clean to w/fines	GW-GC, SP-SM	Sands and gravels which are borderline between clean and with fines	N/A			100%	Varies	-	5% to 12%	Non Plastic	Same as for GW, GP, SW and SP	
III	Coarse-grained soils with fines	GM	Silty gravels, gravel-sand- silt mixtures	Gravel & sand with <10% fines	A-2-4, A- 2-5, A-2- 6, or A-4 or A-6 soils with more than 30% retained on #200 sieve	100%	>50% of "Coarse Fraction"	-	12% to 50%	N/A	<4 or <"A" Line	N/A	
		GC	Clayey gravels, gravel- sand-clay mixtures								<7 & >"A" Line		
		SM	Silty sands, sand-silt mixtures								>4 or <"A" Line		
		SC	Clayey sands, sand-clay mixtures								>7 & >"A" Line		
	Inorganic fine- grained soils	ML	Inorganic silts and very fine sands, rock flour, silty or clayey fine sands, silts with slight plasticity			100%				> 30% (Retained)	<50		<4 or <"A" Line
		CL	Inorganic clays of low to medium plasticity; gravelly, sandy, or silty clays; lean clays										> 30% (Retained)
IV ^(E)	Inorganic fine- grained soils	ML	Inorganic silts and very fine sands, rock flour, silty or clayey fine sands, silts with slight plasticity	N/A	A-2-7 or A-4 or A- 6 soils with 30% or less retained on #200 sieve	100%	100%	-	< 30% (Retained)	<50	<4 or <"A" Line	N/A	
		CL	Inorganic clays of low to medium plasticity; gravelly, sandy, or silty clays; lean clays	N/A							>7 & >"A" Line		
V	Inorganic fine- grained soils	MH	Inorganic silts, micaceous or diatomaceous fine sandy or silty soils, elastic silts	N/A	A5, A7	100%	100%	-	>50%	>50	<"A" Line	N/A	
		CH	Inorganic clays of high plasticity, fat clays	N/A							>"A" Line		
	Organic soils or Highly organic soils	OL	Organic silts and organic silty clays of low plasticity	N/A		100%	100%	-	>50%	>50	<4 or <"A" Line	N/A	
		OH	Organic clays of medium to high plasticity, organic silts	N/A							>50		<"A" Line
		PT	Peat and other high organic soils	N/A									

Notes:

- A) Refer to ASTM D2321 for more complete soil descriptions.
- B) Class I materials allow for a broader range of fines than previous versions of D2321. When specifying Class I material for infiltration systems, the engineer shall include a requirement for an acceptable level of fines.
- C) All particle faces shall be fractured.
- D) Assumes less than 25% passes the 3/8" sieve.
- E) Class IV materials require a geotechnical evaluation prior to use and should only be used as backfill under the guidance of a qualified engineer.

Table 2-7
Secant Constrained Soil Modulus, M_s

Soil Type and Compaction Level (standard Proctor density)									
Class I Crushed Stone		Class II Gravelly Sand				Class III Sandy Silt			
		GW, GP, SW, SP				GM, SM, ML ⁽¹⁾ and GC and SC with <20% passing the 200 sieve			
Geostatic Load P_{sp} Equation 2-1	compacted	uncompacted	100%	95%	90%	85%	95%	90%	85%
	psi (MPa)	psi (MPa)	psi (MPa)	psi (MPa)	psi (MPa)	psi (MPa)	psi (MPa)	psi (MPa)	psi (MPa)
1.04 (0.007)	2350 (16.20)	1275 (8.79)	2350 (16.20)	2000 (13.79)	1275 (8.79)	470 (3.24)	1415 (9.76)	670 (4.17)	360 (2.48)
5.21 (0.036)	3450 (23.79)	1500 (10.34)	3450 (23.79)	2600 (17.93)	1500 (10.34)	520 (3.59)	1670 (11.51)	740 (5.10)	390 (2.69)
10.42 (0.072)	4200 (28.96)	1625 (11.20)	4200 (28.96)	3000 (20.68)	1625 (11.20)	570 (3.93)	1770 (12.20)	750 (5.17)	400 (2.76)
20.83 (0.144)	5500 (37.92)	1800 (12.41)	5500 (37.92)	3450 (23.79)	1800 (12.41)	650 (4.48)	1880 (12.96)	790 (5.45)	430 (2.97)
41.67 (0.287)	7500 (51.71)	2100 (14.48)	7500 (51.71)	4250 (29.30)	2100 (14.48)	825 (5.69)	2090 (14.41)	900 (6.21)	510 (3.52)
62.50 (0.431)	9300 (64.12)	2500 (17.24)	9300 (64.12)	5000 (34.47)	2500 (17.24)	1000 (6.89)			

Notes:

- 1) M_s values presented in the table assume that the native material is at least as strong as the intended backfill material. If the native material is not adequate, it may be necessary to increase the trench width. Refer to the *Installation* section (Section 5) for information on over excavation.
- 2) M_s may be interpolated for intermediate cover heights.
- 3) For M_s values of Class IV materials, contact ADS Application Engineering.

Another soil property used in design, the shape factor (D_f), is a function of pipe stiffness, type of backfill material, and the compaction level. The shape factor relates deflection and bending behaviors. Table 2-8 lists shape factors for a variety of typical installation conditions.

Table 2-8
Shape Factors, D_f

Pipe Stiffness, $PS^{(1)}$ pii (kPa)	Gravel GW, GP, GW-GC, GW-GM, GP-GC and GP-GM (includes crushed stone)		Sand SW, SP, SM, SC, GM, GC or mixtures	
	Dumped to Slight (<85% SPD)	Moderate to High (≥85% SPD)	Dumped to Slight (<85% SPD)	Moderate to High (≥85% SPD)
14 (97)	4.9	6.2	5.4	7.2
16 (110)	4.7	5.8	5.2	6.8
18 (125)	4.5	5.5	5.0	6.5
20 (140)	4.4	5.4	4.9	6.4
22 (150)	4.3	5.3	4.8	6.3
28 (195)	4.1	4.9	4.4	5.9
34 (235)	3.9	4.6	4.1	5.6
35 (240)	3.8	4.6	4.1	5.6
40 (275)	3.7	4.4	3.9	5.4
42 (290)	3.7	4.4	3.9	5.3
46 (320)	3.7	4.3	3.9	5.2
50 (345)	3.6	4.2	3.8	5.1
72 (496)	3.3	3.8	3.5	4.5

Notes:

- 1) Interpolate for intermediate pipe stiffness values.
- 2) For other backfill materials, use the highest shape factor for the pipe stiffness.
- 3) Modified from AASHTO LRFD Section 12, 2008, Table 12-12-3-5-4b-1.

LOADS

Loads are considered to be either a live load or a dead load. Live loads change in position or magnitude, whereas dead loads remain constant throughout the design life of the drainage system. The most commonly considered live loads in pipe applications are vehicular loads, usually from trucks, railroads, and aircraft. The soil load is often the sole dead load consideration; however forces from high groundwater, surcharge, and foundations are also types of dead loads and should be incorporated into the design when appropriate.

LIVE LOADS

Vehicular loads are based on the AASHTO H- or HS- vehicle configurations. Figure 2-1 represents the two types of design truck configurations and the associated loading distribution. Table 2-9 provides the critical controlling load that is exerted at each wheel set or tire area, from the design truck configurations represented in Figure 2-1 or a design tandem rear axle truck (not shown). In railroad applications, the standard load is represented by the Cooper E-80 configuration at 80,000 lbs/ft (1167 kN/m) of track.

**Figure 2-1
AASHTO Highway Loads**

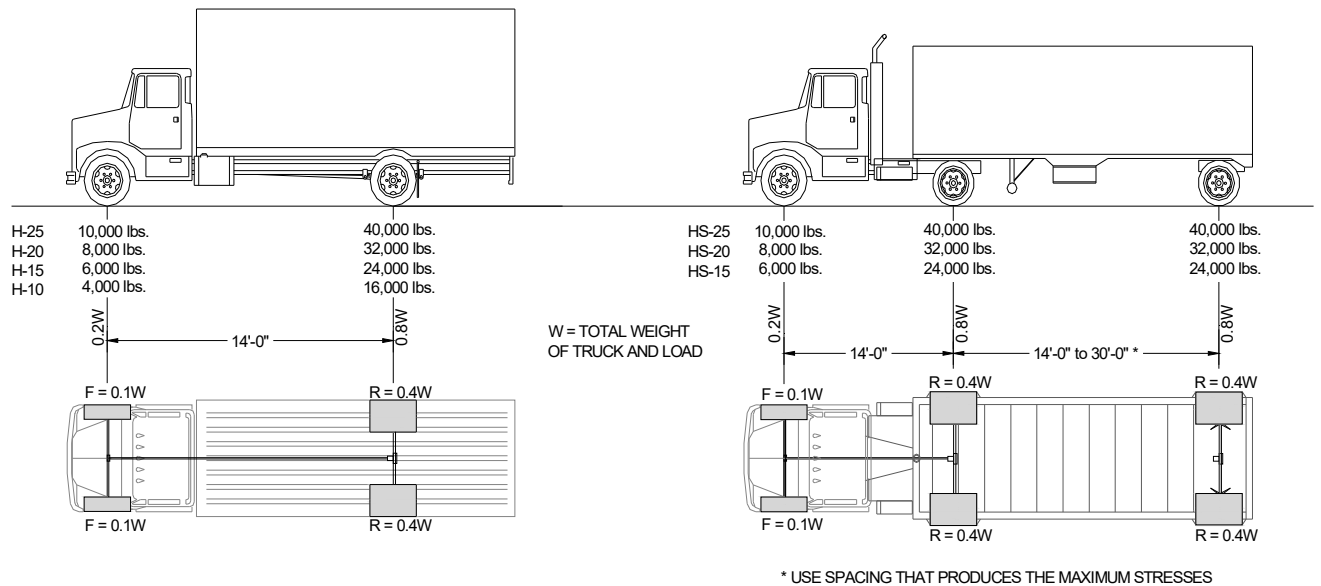

Source: AASHTO Standard Specifications for Highway Bridges

**Table 2-9
AASHTO Highway Loads Carried by Wheel Set**

	H-10 lbs (kN)	H-15 or HS-15 lbs (kN)	H-20 or HS-20 lbs (kN)	H-25 or HS-25 lbs (kN)
W	20,000 (89.0)	30,000 (133.4)	40,000 (178.0)	50,000 (222.4)
F	2,000 (8.9)	3,000 (13.3)	4,000 (17.8)	5,000 (22.2)
R	8,000 (35.6)	12,000 (53.4)	16,000 (71.2)	20,000 (89.0)
R_{AXEL}	16,000 (71.1)	24,000 (106.7)	32,000 (142.3)	40,000 (177.9)

Note: "F" and "R" are represented in Figure 2-1. R_{AXEL} represents the truck's axel load

In applications where the pipe is buried relatively shallow it can experience an additional force from the rolling motion of the vehicle. To account for this additional force, the stationary vehicular load is multiplied by an 'impact factor.' For determination of impact factor for highway loads, AASHTO provides the following equation.

$$IM = 33(1.0 - 0.125H) \geq 0\%$$

Equation 2-1

Where:

- IM = impact factor, %
- H = burial depth, ft

Table 2-10 provides information about the resultant H-25 and E-80 vehicular forces at various cover heights with impact included in the shallow cover situations. Resultant loads for H-20 vehicles can be estimated by decreasing the values in Table 2-10 by 20%. These values are widely used throughout the industry, although values based on alternative computation methods can be substituted.

The intensity of the vehicular load decreases as the depth increases, conversely, the area over which the force acts increases. As shown in Table 2-10, for H-25 loading, live load is negligible beyond 8-feet of fill. Table 2-9 lists the live load distribution width showing this relationship for an AASHTO H-25 or HS-25 load. This width is based on AASHTO information and assumes that the pipe is installed perpendicular to the direction of traffic. Other AASHTO H or HS loads would have identical live load distribution widths. If desired, alternative ways of calculating this value may be used.

Table 2-10
Live Load Data for AASHTO H-25, HS-25, and Cooper E-80

Cover, ft. (m)	AASHT O H-25 or HS-25 ⁽¹⁾		Cooper E-80 ⁽¹⁾	Cover, ft. (m)	AASHTO H-25 or HS-25 ⁽¹⁾		Cooper E-80 ⁽¹⁾
	Live Load Transferred to Pipe, psi (MPa)	Live Load Distribution Width, L _w in. (mm)	Live Load Transferred to Pipe, psi (MPa)		Live Load Transferred to Pipe, psi (MPa)	Live Load Distribution Width, L _w In. (mm)	Live Load Transferred to Pipe, psi (MPa)
1 (0.3)	32.0 (0.220)	34 (860)	N/R	14 (4.3)	negligible	N/A	4.17 (0.288)
2 (0.6)	13.9 (0.958)	48 (1210)	26.39 (0.182)	16 (4.9)	negligible	N/A	3.47 (0.239)
3 (0.9)	7.6 (0.524)	61 (1561)	23.61 (0.163)	18 (5.5)	negligible	N/A	2.78 (0.192)
4 (1.2)	4.9 (0.338)	147 (3740)	18.40 (0.127)	20 (6.1)	negligible	N/A	2.08 (0.143)
5 (1.5)	3.5 (0.241)	161 (4090)	16.67 (0.115)	22 (6.7)	negligible	N/A	1.91 (0.132)
6 (1.8)	2.7 (0.186)	175 (4441)	15.63 (0.108)	24 (7.3)	negligible	N/A	1.74 (0.120)
7 (2.1)	2.1 (0.145)	189 (4791)	12.15 (0.838)	26 (7.9)	negligible	N/A	1.39 (0.095)
8 (2.4)	1.6 (0.110)	202 (5142)	11.11 (0.766)	28 (8.5)	negligible	N/A	1.04 (0.072)
10 (3.0)	negligible	N/A	7.64 (0.527)	30 (9.1)	negligible	N/A	0.69 (0.048)
12 (3.7)	negligible	N/A	5.56 (0.383)	35 (10.7)	negligible	N/A	negligible

- 1) Includes impact.
- 2) N/R indicates that the cover height is not recommended.
- 3) N/A indicates that the information is not applicable.

Loads from aircraft vary widely in magnitude and distribution. The FAA Design Manual should be referenced for more specific information. Some construction vehicles may pose a temporary, although severe, live load consideration. On the other hand, other construction vehicles may weigh substantially less than the design load. For very large loads, mounding additional cover over the pipe when necessary, then grading following construction may be warranted in situations where the pipe has little cover. Construction vehicles with loads lighter than the design load may be permitted over the pipe, during the construction phase only, with less than the minimum recommended cover. Construction loads are covered in additional detail in the *Installation* section (Section 5).

DEAD LOADS

The soil load is calculated in this design procedure using a soil arch load (W_{sp}). Rather than using a soil column load, the actual soil load is less than the calculated column load because the column is supported, in part, by adjacent soil columns.

Soil Arch Load (W_{sp})

The soil arch load (W_{sp}) most closely represents the actual soil load experienced by a flexible pipe. The arch load calculation uses a vertical arching factor (VAF) to reduce the earth load in order to account for the support provided by adjacent soil columns.

The arch load is determined using the procedure described below. First, the geostatic load is calculated by determining the weight of soil directly above the outside diameter of the pipe plus a small triangular load extending just beyond the outside diameter. The equation for the geostatic load, P_{sp} , is shown in Equation 2-2.

$$P_{sp} = \frac{(\gamma_s) \left(H + 0.11 \frac{OD}{12} \right)}{144} \quad \text{Equation 2-2}$$

Where:

P_{sp} = geostatic load, psi

H = burial depth, ft

γ_s = unit weight of soil, pcf

OD = outside diameter of pipe, in (Table 2-1 - 2-4)

Next, the vertical arching factor (VAF) must be determined. This factor accounts for the support provided by adjacent soil columns by reducing the geostatic load. The vertical arching factor is computed as shown in Equation 2-3.

$$\text{VAF} = 0.76 - 0.71 \left(\frac{S_h - 1.17}{S_h + 2.92} \right) \quad \text{Equation 2-3}$$

Where:

VAF = vertical arching factor, unitless

S_h = hoop stiffness factor;

= $\phi_s M_s R / (E A)$

ϕ_s = capacity modification factor for soil, 0.9

M_s = secant constrained soil modulus, psi (Table 2-7)

R = effective radius of pipe, in

= $ID/2+c$

ID = inside diameter of pipe, in (Table 2-1 - 2-4)

- c = distance from inside diameter to neutral axis, in
 (Product Note 2.01 thru 2.05)
 E = modulus of elasticity, psi initial and long term (Table 2-5)
 A = section area, in²/in (mm²/mm) (Product Note 2.01 - 2.05)

After the geostatic load, P_{sp} , and the VAF have been determined the soil arch load can be found as shown in Equation 2-4.

$$W_{sp} = (P_{sp})(VAF) \quad \text{Equation 2-4}$$

Where:

- W_{sp} = soil arch load, psi
 P_{sp} = geostatic load, psi
 VAF = vertical arching factor, unitless

Hydrostatic Loads

The pressure of groundwater must also be accounted for only if present at or above the pipe springline. Equations 2-5 provide the method to calculate hydrostatic pressure. Where hydrostatic pressure is present, the geostatic load (P_{sp}) should be adjusted to account for the buoyant weight of the soil in the saturated zone.

$$P_w = \frac{\gamma_w (H_s)}{144} \quad \text{Equation 2-5}$$

Where:

- P_w = hydrostatic pressure at springline of pipe, psi
 γ_w = unit weight of water, 62.4 pcf
 H_s = height of groundwater above springline of pipe, ft

Foundation Loads

In some custom pipe installations, pipes are positioned beneath or near foundations. Where this type of installation is permitted, this load contribution must be added to the dead load before proceeding with the design process. Soil mechanics textbooks include procedures to determine the effect of foundation loads some distance away from the point of application. ADS does not recommend pipe being installed parallel to a foundation load, where the pipe is positioned within the influence line of the foundation.

2-4 THERMOPLASTIC PIPE DESIGN PROCEDURE

This section sets forth the design methodology for corrugated polyethylene and polypropylene pipe based on AASHTO Load and Resistance Factor Design (LRFD) Bridge Design Specifications Section 12: Buried Structures and Tunnel Liners (2008 Interim Revision). Design of corrugated polyethylene and polypropylene pipe in non-pressure applications involves calculating wall thrust, bending strain, buckling, and strain limits based on combined tension and compressive conditions. Criteria for pipe, installation conditions, and loads from Section 2-3 are required for this procedure; references are made to areas where the required information can be found. Minimum and Maximum burial depths depend on the application, product, backfill material, and compaction level; please refer to the Appendix A-5 in the *Installation* section for a listing of appropriate technical literature and standard details related to ADS products and applications. All technical literature listed in this chart is available on the ADS website. Contact ADS for any installations with deep fill heights or custom applications.

In this design procedure, the pipe is evaluated at various limit states to ensure the objectives of constructability, safety, and serviceability are obtained. The pipe is first analyzed for the service limit states with restrictions on stress and deformation. Next the pipe is evaluated at strength limit states for wall area, buckling, thrust, and combined strain. Each condition is evaluated to ensure that strength and stability, both global and locally, are provided to resist the specified load combinations expected.

LOAD AND RESISTANCE FACTORS

In Load and Resistance Factor Design (LRFD), the loads applied to the structure and the resistance of a given structure or element to resist the load are multiplied by modification factors to introduce a factor of safety to each criterion. While modification factors are generally provided in the design method, it is left up to the user to choose between a range of factors for a given application. As stated by AASHTO, "Factors have been developed from the theory of reliability based on current statistical knowledge of loads and structural performance." These factors should be chosen based on the criterion they are applied to and the severity of the application.

Tables 2-11 thru 2-13 below provide modification factors which are used throughout this design method. Within each equation that follows, references to these tables will be provided with a recommended modification factor where appropriate.

Table 2-11
Load Factors (γ)

Load Combination Limit State	Vertical Earth Pressure γ_{EV}	Water Load γ_{WA}	Vehicular Live Load γ_{LL}
Strength Limit I	0.9-1.95	1.0-1.3	1.75
Strength Limit II	0.9-1.95	1.0-1.3	1.35
Service Limit I	1.0	1.0	1.0

Table 2-12
Resistance Factors (ϕ)

Structure Type	ϕ
Min Wall Area	1.0
Buckling	1.0
Flexure	1.0
Pipe	1.0
Soil	0.9

Table 2-13
Load Modifiers (η)

Load Combination	η	Redundancy
Earth Fill	1.05	Non-redundant
Live Load	1.0	Redundant
Construction Load	1.0	Redundant

WALL THRUST

Thrust, or stress, in the pipe wall is determined by the total load on the pipe including soil loads, vehicular loads, and hydrostatic forces. The pipe must be able to withstand these forces in both tension and compression in order for it to remain structurally stable. The critical wall thrust (T_{cr}^{ten}), determined in Equation 2-9 and the critical wall thrust for compression (T_{cr}^{comp}) determined in Equation 2-10, must be equal to or greater than the wall thrust (T_L) calculated in Equations 2-8.

Since thrust is later used for the purpose of determining strain, it is recommended in this step of the design procedure to calculate both a short term and long term thrust component using short term and long term loading conditions respectfully. For the trust comparison of critical wall thrust to actual wall thrust, the short term and long term thrust components can simply be added together for analysis.

Calculated Wall Thrust**Short Term Thrust**

$$T_{L-s} = (\eta_{LL} \gamma_{LL} P_l C_l) \left(\frac{OD}{2} \right) \quad \text{Equation 2-6}$$

Long Term Thrust

$$T_{L-L} = \left[\eta_{EV} (\gamma_{EV} W_{sp} + \gamma_{WA} P_w) \right] \left(\frac{OD}{2} \right) \quad \text{Equation 2-7}$$

Combined Thrust

$$T_L = T_{L-L} + T_{L-s} \quad \text{Equation 2-8}$$

Where:

T_{L-s} = factored wall thrust due to short term loading, lb/in

T_{L-L} = factored wall thrust due to long term loading, lb/in

T_L = factored wall thrust, lb/in

W_{sp} = soil arch load, psi (Equation 2-3)

η_{EV} = load modifier, earth fill, (Table 2-12)

γ_{EV} = load factor, vertical earth pressure, (Table 2-11)

γ_{WA} = load factor, water load (Table 2-11)

η_{LL} = load modifier, live load (Table 2-13)

γ_{LL} = load factor, live load (Table 2-11)

P_l = live load transferred to pipe, psi (Table 2-10)

C_l = live load distribution coefficient

= the lesser of $\frac{L_w}{OD}$ or 1.0

L_w = live load distribution width at the crown, in (Table 2-10)

OD = outside diameter, in (Table 2-1 - 2-4)

P_w = hydrostatic pressure at springline of pipe, psi (Equation 2-5)

Actual thrust calculated (T_L) is a compressive thrust. An internal load, such as internal pressure, would have to result in a tensile thrust greater than the compressive thrust calculated here in order for tensile thrust to be greater than zero. The actual tensile thrust is 0psi for corrugated pipe installed under typical installation conditions.

Tensile Resistance to Thrust

$$T_{cr}^{ten} = (F_y)(A)(\phi_p) \quad \text{Equation 2-9}$$

Where:

T_{cr}^{ten} = critical wall thrust resistance in tension, lb/linear inch of pipe

F_y = tensile strength, psi initial or long term (Table 2-5)

A = wall area, in²/inch of pipe (Product Note 2.01 – 2.05)
 ϕ_p = capacity modification factor for pipe, 1.0 (Table 2-11)

Compressive Resistance to Thrust

$$T_{cr}^{comp} = (F_y)(A_{eff})(\phi_p) \tag{Equation 2-10}$$

Where:

T_{cr}^{comp} = critical wall thrust resistance in compression, lb/linear inch of pipe

F_y = tensile strength, psi initial or long term (Table 2-5)

A_{eff} = effective wall area, in²/inch of pipe (Equation 2-11)

ϕ_p = capacity modification factor for pipe, 1.0 (Table 2-12)

Effective Area (A_{eff})

The effective area of a profile wall flexible pipe is the amount of total area which is “effective” in withstanding a given compressive force in the pipe wall. Under this principal, it is assumed only a portion of the pipe wall resists compressive forces

In order to determine the effective area, AASHTO LRFD design method reduced the actual pipe profile to an idealized profile, both shown in Figure 2-2, in order to simplify the design procedure. The idealized profile is a representation of the actual profile but with straight sides and sharp corners. The thin straight elements that make up the idealized profile are analyzed to determine their effective width and resistance to buckling. Once the effective width of each element is calculated, a reduced effective area is calculated and used to analyze the structural integrity of the pipe section.

**Figure 2-2
 Typical and Idealized Corrugation Profiles**

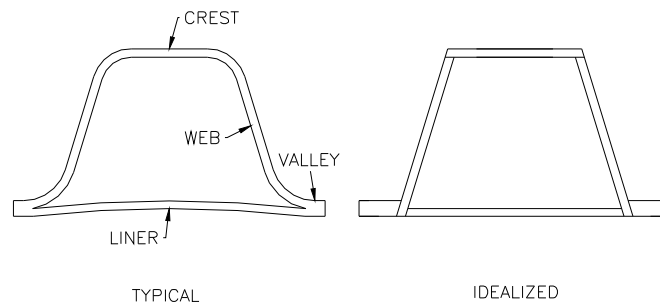

In order to determine the effective width of each element, the idealized profile geometry must be known. This must be determined through meticulous profile measurements to determine the thickness and width of each profile element. The results of such an analysis are provided in ADS Product Notes 2.01 – 2.05.

$$A_{eff} = A_s - \frac{\sum (1 - \rho_i) w_i t_i}{\omega} \quad \text{Equation 2-11}$$

Where:

A_{eff} = effective wall area, in²/inch of pipe

A_s = wall area, in²/in (Product Note 2.01 – 2.05)

w_i = length of each individual profile element, in (Product Note 2.01 – 2.05)

t_i = thickness of each individual profile element, in (Product Note 2.01 – 2.05)

ω = profile pitch, in (Product Note 2.01 – 2.05)

$$\rho_i = \frac{1 - \frac{0.22}{\lambda_i}}{\lambda_i} \leq 1 \quad \text{Equation 2-12}$$

Where:

ρ_i = effective width factor

$$\lambda_i = \frac{w_i}{t_i} \sqrt{\frac{\varepsilon}{k}} > 0.673 \quad \text{Equation 2-13}$$

Where:

λ_i = slenderness factor

w_i = length of each individual profile element, in (Product Note 2.01 – 2.05)

t_i = thickness of each individual profile element, in (Product Note 2.01 – 2.05)

k = edge support coefficient, 4.0 for elements with both edges supported

ε = material strain limit, in/in (Table 2-5)

BUCKLING

The potential for general pipe wall buckling is determined by the burial conditions (M_s) and the pipe profile properties (A_{eff} , I , R). The critical buckling stress found from Equation 2-14 must be greater than the actual yield stress (F_y). If the critical buckling stress is less than the yield stress, then the compressive resistance to thrust, Equation 2-10, must be recalculated using f_{cr} in place of F_y .

Critical Buckling Stress

$$f_{cr} = 9.24 \frac{R}{A_{eff}} \sqrt{B' R_w \phi_s M_s \frac{EI}{0.149R^3}}$$

Equation 2-14

Where:

f_{cr} = critical buckling stress, psi

M_s = secant constrained soil modulus, psi (Table 2-7)

R = effective radius of pipe, in
= $ID/2+c$

ID = inside diameter of pipe, in (Table 2-1 - 2-4)

c = distance from inside diameter to neutral axis, in
(Product Note 2.01 – 2.05)

E = modulus of elasticity, psi initial and long term (Table 2-5)

A_{eff} = effective area, in²/ft (Equation 2-11)

I = moment of inertia, in⁴/in (Product Note 2.01 – 2.05)

R_w = water buoyancy factor
= $1-0.33h_g/H$

H = burial depth, ft

h_g = height of groundwater above crown of pipe, ft

ϕ_s = resistance factor for soil stiffness (Table 2-12)

B' = nonuniform stress distribution factor

$$= \frac{1}{1 + 4e^{-0.065H}}$$

COMPRESSIVE STRAIN

An incorrect assumption in calculating actual compressive strain in a pipe wall is to assume all load is applied long-term. Due to the viscoelastic behavior of both polyethylene and polypropylene resins, pipe response under given loading conditions should be analyzed with the material properties most closely representing the loading condition. In this analysis, applied compressive strain (ϵ_{uc}) is determined from Equation 2-15 and then compared to limiting material strain (ϵ), Table 2-5, to ensure material capacity is not exceeded.

Factored Compressive Strain

$$\epsilon_{uc} = \frac{T_L}{A_{eff} E} = \frac{T_{L-L}}{E_L A_{eff}} + \frac{T_{L-S}}{E_S A_{eff}}$$

Equation 2-15

Where:

ϵ_{uc} = factored compressive strain, in/in

T_{L-S} = factored wall thrust due to short term loading, lb/in

T_{L-L} = factored wall thrust due to long term loading, lb/in

A_{eff} = effective wall area, in²/inch of pipe (Equation 2-11)

E_L = long term modulus of elasticity, psi (Table 2-5)

E_S = short term modulus of elasticity, psi (Table 2-5)

BENDING STRAIN

A check on the bending strain will ensure that it is within material capability. In place of a more detailed analysis of bending strain, the strain calculated in this method is based on an empirical relationship between strain and deflection due to loading conditions. In order to account for construction induced deflections, a predetermined limit is introduced into the deflection equation. This results in total deflection due to bending. Once deflection due to bending is determined from Equation 2-16, bending strain can be found with Equation 2-17. The bending strain limit is material specific as shown in Table 2-5.

Pipe Deflection Due to Bending

$$\Delta = \Delta_c ID - \frac{T_L D_m}{A_{eff} E \gamma_p} = \Delta_c ID - \frac{\epsilon_{uc} D_m}{\gamma_{EV}} \quad \text{Equation 2-16}$$

Where:

Δ = deflection of pipe, reduction of vertical diameter due to bending, in

Δ_c = deflection of pipe, construction induced deflection limit 5%

ϵ_{uc} = factored compressive strain, in/in (Equation 2-15)

γ_{EV} = load factor, vertical earth pressure, (Table 2-11)

ID = inside diameter of pipe, in (Table 2-1 - 2-4)

D_m = mean pipe diameter, in
= ID + 2c

c = distance from inside diameter to neutral axis, in
(Product Note 2.01 – 2.05)

Factored Bending Strain

$$\epsilon_{bu} = \gamma_B D_f \left(\frac{c_x}{R} \right) \left(\frac{\Delta}{D_m} \right) \quad \text{Equation 2-17}$$

Where:

ϵ_{bu} = factored bending strain, in/in

D_f = shape factor, dimensionless (Table 2-8)

Δ = deflection, in (Equation 2-16)

γ_B = load factor, combined strain, 1.5

R = effective radius of pipe, in
= ID/2+c

ID = inside diameter of pipe, in (Table 2-1 - 2-4)

c_x = distance from neutral axis to extreme fiber, in (Product Note 2.01 – 2.05)

D_m = mean pipe diameter, in
= ID + 2c

COMBINED STRAIN

If it is determined bending strain is within the allowable limit, the combined strain due to bending and thrust must be checked to make sure they do not exceed the factored strain limits. These shall be checked for both compression and tension conditions. The factored combined compressive strain determined from Equation 2-18 shall not exceed the limiting combined compressive strain determined from Equation 2-19. Additionally, the factored combined tension strain determined from Equation 2-20 shall not exceed the limiting combined tension strain determined from Equation 2-21.

Factored Combined Compressive Strain

$$\epsilon_{cu} = \epsilon_{bu} + \epsilon_{uc} \frac{\gamma_B}{\gamma_P} \quad \text{Equation 2-18}$$

Where:

ϵ_{cu} = factored compressive strain, in/in

ϵ_{bu} = factored bending strain, in/in (Equation 2-17)

ϵ_{uc} = factored compressive strain, in/in (Equation 2-15)

γ_P = load factor, vertical earth pressure (Table 2-11)

γ_B = load factor, combined strain, 1.5

Limiting Combined Compressive Strain

$$\epsilon_{cl} = \left(\frac{1.5F_y}{E_{50}} \right) \quad \text{Equation 2-19}$$

Where:

ϵ_{cl} = limiting combined compressive strain, in/in

F_y = Long term tensile strength, psi (Table 2-5)

E_{50} = long term modulus of elasticity, psi (Table 2-5)

Factored Combined Tension Strain

$$\epsilon_{tu} = \epsilon_{bu} - \epsilon_{uc} \frac{\gamma_B}{\gamma_P} \quad \text{Equation 2-20}$$

Where:

ϵ_{tu} = factored tension strain, in/in

ϵ_{bu} = factored bending strain, in/in (Equation 2-17)

ϵ_{uc} = factored compressive strain, in/in (Equation 2-15)

γ_p = load factor, vertical earth pressure (Table 2-11)

γ_B = load factor, combined strain, 1.5

Limiting Combined Tension Strain

$$\varepsilon_{tl} = \gamma_B \varepsilon_t$$

Equation 2-21

Where:

ε_{tl} = limiting combined tension strain, in/in

γ_B = load factor, combined strain, 1.5

ε_t = allowable tension strain, in/in (Table 2-5)

2-5 RESEARCH AND INSTALLATIONS

Corrugated polyethylene pipe has been heavily researched in the laboratory and through actual installations. This section summarizes the findings of some of those projects; additional information about these and other reports can be obtained from ADS.

“Analysis of the Performance of a Buried High Density Polyethylene Pipe.” Written by Naila Hashash and Ernest Selig, University of Massachusetts, and published in *Structural Performance of Flexible Pipes*, edited by Sargand, Mitchell, and Hurd, October 1990, pp. 95 - 103.

In 1988, the Pennsylvania Department of Transportation began a study to evaluate the behavior of polyethylene pipe similar to ADS AASHTO pipe backfilled with crushed stone under a 100 foot (30.5m) burial depth. This document, which is a status report of the pipe condition 722 days after installation, summarizes one of the most heavily instrumented pipe installations to date. Measured vertical deflection was 4.6% and horizontal deflection was 0.6%. Much of this was due to a slight (1.6%) circumferential shortening. This amount of deflection is well within the 7.5% generally accepted limit. Soil arching reduced the load on the pipe by 77% which shows that the soil column load is a very conservative method to estimate this load component.

“Field Performance of Corrugated Polyethylene Pipe.” Written by John Hurd, Ohio Department of Transportation, and published in *Public Works*, October 1987.

This article summarizes the results of a field study conducted in 1985 on 172 culvert installations. These installations represented real-world applications where backfill procedures may or may not have been conducted in accordance with standard ODOT recommendations. Regardless, the primary findings regarding structural integrity were that shallow cover, even with heavy truck traffic, did not appear to cause significant amounts of deflection; what deflection that did occur seemed to be due to installation.

“Laboratory Test of Buried Pipe in Hoop Compression.” Written by Ernest Selig, Leonard DiFrancesco, and Timothy McGrath, and published in *Buried Plastic Pipe Technology - 2nd Volume*, 1994, pp. 119 - 132.

The project involved developing a fixture so as to subject the pipe to purely compressive forces. A pressure of 55 psi (379 kPa) was reached at which time equipment problems developed. The authors indicated this pressure was the equivalent of 100 feet (30.5m) of cover in other tests they had performed. At this pressure, the pipe also experienced a 3% circumferential shortening which resulted in a significant beneficial soil arching.

“Pipe Deflections - A Redeemable Asset.” Written by Dr. Lester Gabriel and published in *Structural Performance of Flexible Pipes*, edited by Sargand, Mitchell, and Hurd, October 1990, pp. 1 - 6.

This paper provides an easy-to-read description of the role of deflection in properly performing flexible pipe. Deflection is not a liability, but a behavior

that forces the backfill material to take on a disproportionate amount of load. Deflection allows flexible pipe to be installed in applications with surprisingly deep burials.

“Short-term Versus Long-term Pipe Ring Stiffness in the Design of Buried Plastic Sewer Pipes.” Written by Lars-Eric Janson and published in *Pipeline Design and Installation*, proceedings from the International Conference sponsored by the Pipeline Planning Committee of the Pipeline Division of the American Society of Civil Engineers, March 1990, pp. 160 - 167.

This report describes the viscoelastic behavior of polyethylene. The author suggests use of short-term properties when the pipe is backfilled in friction soils or firm silty/clayey soils.

“Stress Relaxation Characteristics of the HDPE Pipe-Soil System.” Written by Larry Petroff and published in *Pipeline Design and Installation*, proceedings from the International Conference sponsored by the Pipeline Planning Committee of the Pipeline Division of the American Society of Civil Engineers, March 1990, pp. 280-293.

This is an excellent report on the viscoelastic nature of polyethylene and discusses both creep and stress relaxation behaviors. One of the major points made is how deflection decreases with time; over 80% of the total deflection that a pipe will experience throughout its life will occur within the first 30 days. Petroff also indicated that the highest stresses for polyethylene pipe buried in a compacted granular material occur soon after installation but relax soon thereafter.

“Stiffness of HDPE Pipe in Ring Bending.” Written by Timothy McGrath, Ernest Selig, and Leonard DiFrancesco, and published in *Buried Plastic Pipe Technology- 2nd Volume*, 1994, pp. 195 - 205.

This project was conducted to determine how or if the modulus of elasticity changes over time. The pipe was deflected and held in position to generate a stress/strain curve. Although the results gave the appearance that the material was losing strength over time, repeated incremental loads caused the pipe to respond with its short-term modulus.

“Structural Performance of Three-Foot Corrugated Polyethylene Pipe Buried Under High Soil Cover.” Written by Reynold Watkins and published in *Structural Performance of Flexible Pipes*, edited by Sargand, Mitchell, and Hurd, October 1990, pp. 105 - 107.

A three-foot (900mm) diameter corrugated polyethylene pipe was tested in a load cell to determine if it performed as well as the smaller sizes. The author recognizes the effects of stress relaxation. The report concludes “There is no reason why corrugated polyethylene pipes of three-foot diameter cannot perform structurally under high soil cover provided that a good granular pipe zone backfill is carefully placed and compacted.” This is consistent with the backfill and material recommendations set forth in previous sections.

Hydraulics



3-0 HYDRAULICS

TABLE OF CONTENTS

- 3-1 Overview of Hydraulic Considerations 3-2
- 3-2 Design Manning’s Value 3-2
- 3-3 Discharge Curves 3-4
- 3-3 The Conveyance Method 3-8
- 3-4 Minimum Velocity Considerations..... 3-12
- 3-5 Maximum Velocity Considerations..... 3-12
- 3-6 Long Term Pressure Considerations 3-13
- 3-7 Culvert Considerations 3-14
- 3-8 Example Problems 3-15
- 3-9 Footnotes..... 3-17

Figures

- 3-1 Discharge Rates for ADS Corrugated Pipe with Smooth Interior Liner 3-5
- 3-2 Discharge Rates for ADS Single Wall Heavy Duty and Highway Pipe 3-6
- 3-3 Discharge Rates for ADS Triplewall® and Smoothwall Sewer & Drain Pipe 3-7

Tables

- 3-1 Conveyance Factors (Standard Units)..... 3-10
- 3-2 Conveyance Factors (Metric Units) 3-11
- 3-3 Entrance Loss Coefficients 3-14

BUYER/USER IS RESPONSIBLE FOR SERVICEABILITY OF THE PRODUCT IN ANY GIVEN APPLICATION. SELLER IS NOT RESPONSIBLE FOR INJURY OR DAMAGE RESULTING FROM IMPROPER INSTALLATION, NONCOMPLIANCE WITH THESE GUIDELINES FOR INSTALLATION OF PRODUCT, OR USE OUTSIDE THE GUIDELINES SET FORTH HEREIN.

3-1 OVERVIEW OF HYDRAULIC CONSIDERATIONS

The Manning's equation is the most widely recognized means of determining pipe capacity for gravity flow installations. As such, it provides the basis of the hydraulic design consideration for corrugated high density polyethylene (HDPE) and polypropylene (PP) pipe.

Discharge curves allow pipe sizing through use of graphs once the design capacity requirements and slope have been established. Each product will have its own discharge curve based on its Manning's "n" value. This section provides flow capacities based on recommended design "n" values for ADS products. It should be noted that factors such as bends, manhole connections, debris and sediment result in hydraulic losses that will affect actual flow capacity and should be considered in final pipe selection.

By reducing all of the coefficients and constants in the Manning equation down to a single factor, called the conveyance factor (K), another method of pipe sizing can be utilized. By knowing the Manning's "n" value for various pipe materials, the use of conveyance factor charts will allow the designer to develop comparative product options easily. Use of this method frequently results in more than one satisfactory pipe type and size for a given drainage need, thereby allowing the designer to compare product options in order to determine the most cost-effective solution.

Final pipe selection should also include a review of the velocity conditions. Higher flow velocities help keep sediment contained in stormwater from settling along the bottom of the pipe. A reduction in sediment can also reduce the frequency of maintenance and help ensure that the hydraulic function of the pipe will continue throughout its design life. These velocities, however, must be kept within the maximum performance limits of the pipe and the associated facility.

3-2 DESIGN MANNING'S VALUE

Within the pipe industry, there is a wide range of Manning's "n" values, or roughness coefficients, for various types of pipe. Several items should be considered prior to selecting an "n" value for a given pipe material when designing any gravity flow system.

1. Manning's "n" values developed for any given pipe material will depend on depth of flow for partially full pipe and flow velocity for full flow conditions. Manning's "n" values are commonly provided for full flow conditions, but should not be assumed unless specifically noted. For most calculations, "n" is assumed to be constant; however, it shall be the discretion of the individual designer to use a constant or varying "n" value.

2. Storm sewers, culverts and sanitary sewers are typically subject to collection of debris and sediment, which adversely effect flow rates. Consideration should be given for the collection of debris and sedimentation and adjust the design “n” value accordingly. Pipe inside surface texture, geometry, joint opening and pipe material can also influence collection of debris and sedimentation depending on the susceptibility of the debris to either adhere to the pipe surface or be trapped and caught by other obstructions.

Tests conducted at Utah State University Water Research Laboratory show minimum Manning’s “n” values of less than 0.010 for corrugated HDPE pipe with a smooth interior liner. To accommodate actual field conditions and to incorporate a safety factor, ADS recommends using a Manning’s “n” value of 0.012 for corrugated HDPE and PP products with a smooth interior liner. There is considerable justification for both HDPE and PP products to be designed with the same Manning’s “n” value. Both smooth interior products are made using the same mold blocks and are produced on the same manufacturing equipment. From a material standpoint, both HDPE and PP are polyolefin materials, very similar in chemical makeup, that behave similarly during processing. Also, ADS performs regular internal quality checks which assure the liner roughness of polypropylene is equal to, if not better than, the liner roughness of HDPE products with an established Manning’s “n” value of 0.012. In general, it is common engineering practice to include a safety factor of 20-30% to the Manning’s values determined during laboratory testing. However, it should be noted, this practice is not utilized for most Manning’s “n” values provided for metal pipes. Recommended design Manning’s “n” values for all ADS pipe products are listed in Table 3-1.

3-2 DISCHARGE CURVES

The mathematical relationship of the terms included in the Manning's formula is often shown graphically through discharge curves. Discharge curves are one method of selecting an adequate pipe size, once the required capacity and slope have been determined.

Discharge curves for ADS HDPE and PP pipe products under gravity flow steady state conditions are shown in Figures 3-1 through 3-3.

Figure 3-1
Discharge Rates for ADS Corrugated Pipe with Smooth Interior Liner¹

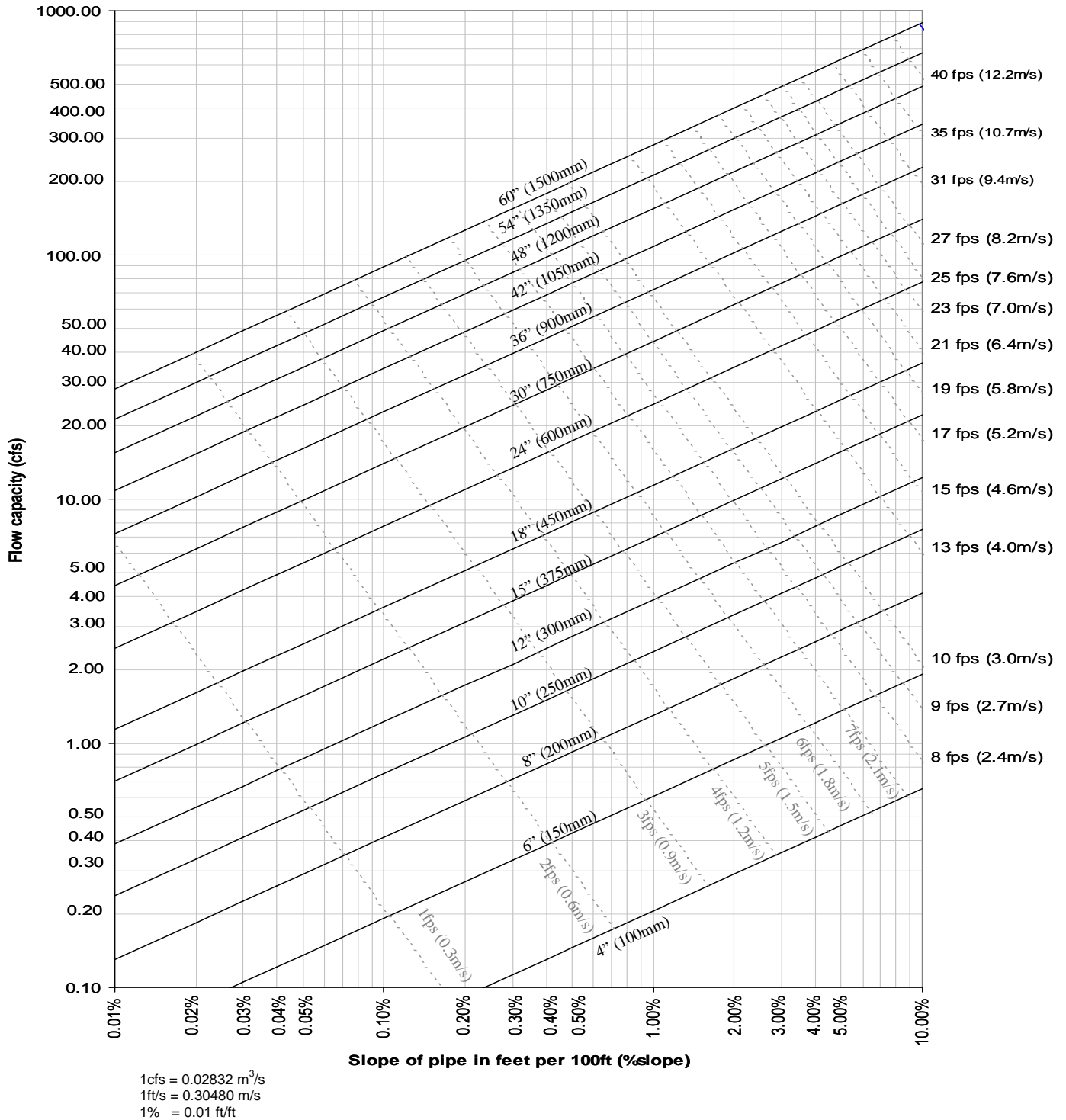

1. Applicable products: N-12[®], MEGA GREEN[®], N-12 STIB, N-12 WTIB, HP STORM, SaniTite[®], SaniTite HP, N-12 Low Head

Note: Based on a design Manning's "n" of 0.012.
 Solid lines indicate pipe diameters. Dashed lines indicate approximate flow velocity.
 Redeveloped from FHWA HDS 3 – Design Charts for Open-Channel Flow²

Figure 3-2
Discharge Rates for ADS Single Wall Heavy Duty and Highway Pipe

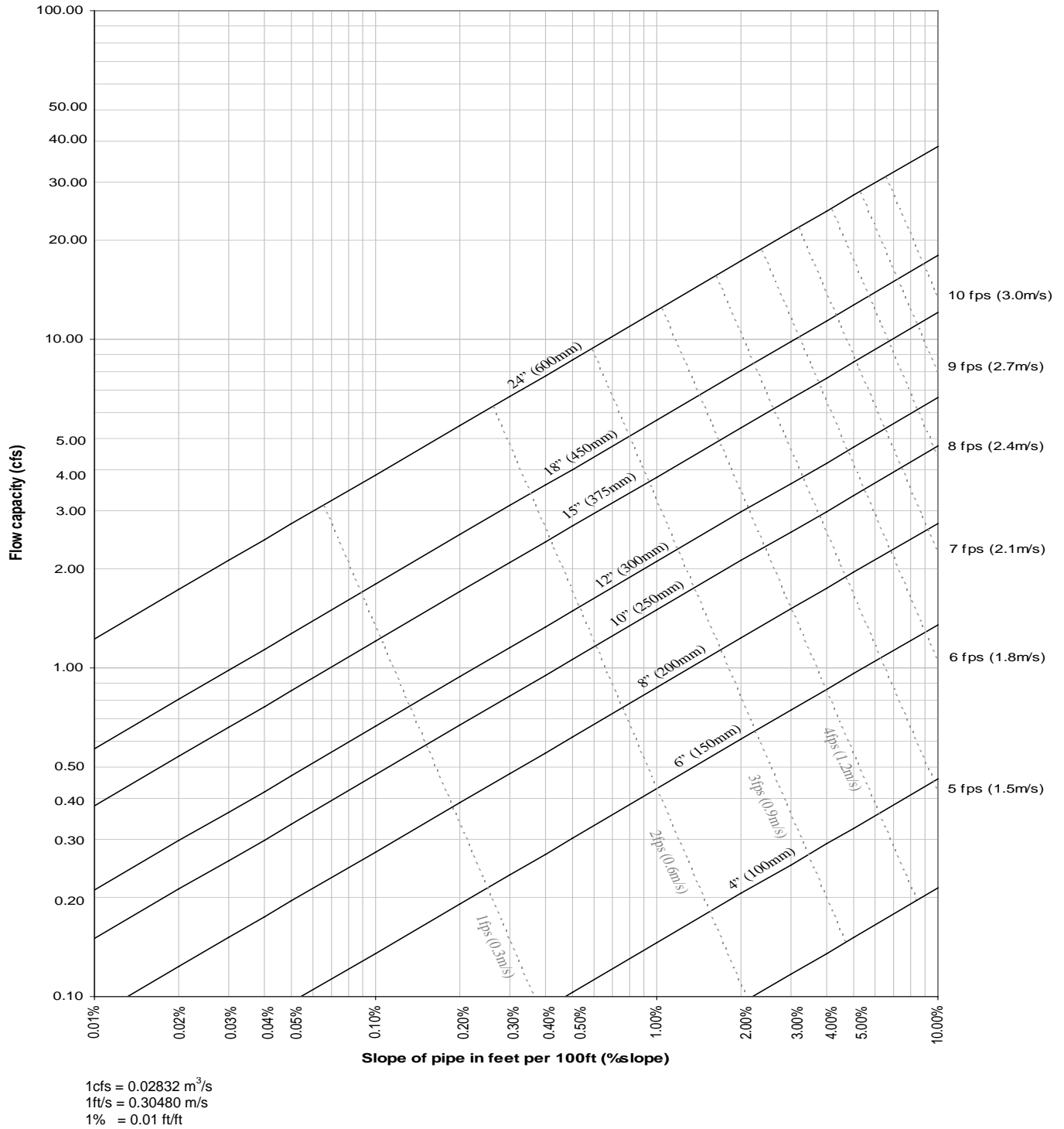

Note: Based on a design Manning's "n" described in Table 3-1 for respective diameter.
 Pipe may not be available in all diameters shown.
 Solid lines indicate pipe diameters. Dashed lines indicate approximate average velocity.

Figure 3-3
Discharge Rates for ADS TripleWall® and Smoothwall Sewer & Drain Pipe

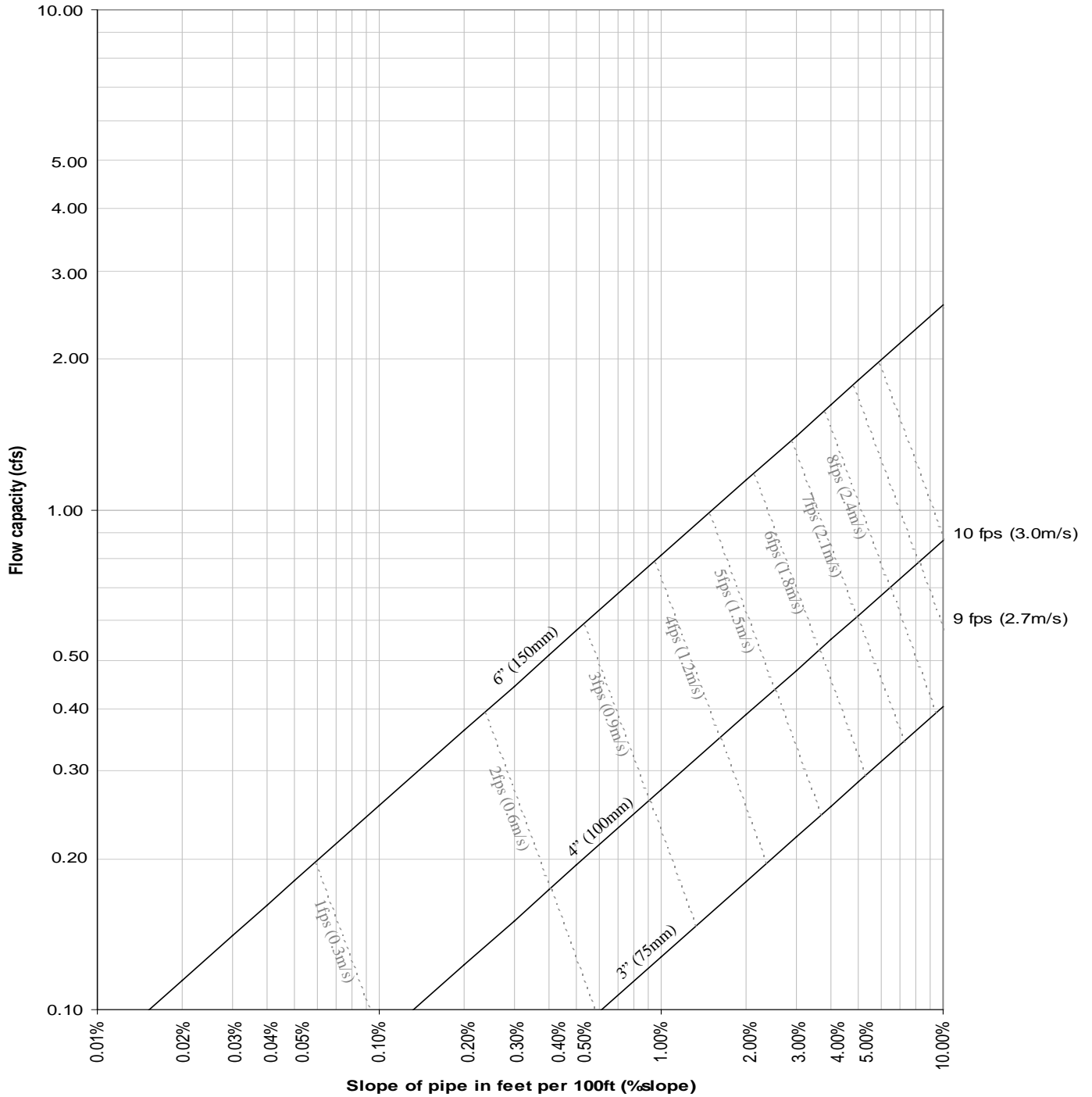

1cfs = 0.02832 m³/s
 1ft/s = 0.30480 m/s
 1% = 0.01 ft/ft

Note: Based on a design Manning's "n" of 0.009.
 Solid lines indicate pipe diameters. Dashed lines indicate approximate average velocity.

3-3 THE CONVEYANCE METHOD

Conveyance provides a convenient means of selecting a variety of pipe options that will satisfy a project's flow requirements. Conveyance factors are based on a greatly simplified version of the Manning's equation shown in Equation 3-1 and 3-1 (a). In the following discussion, example problems and subsequent sections, the pipe is assumed to be flowing full. This assumption typically allows for a simplified, yet accurate analysis of the given conditions. Each project should be evaluated on a case-by-case basis to determine the best, most-representative design method.

$$Q = \frac{(1.486)(A)(R^{2/3})(S^{1/2})}{n} \quad \text{Equation 3-1}$$

Where:

Q = pipe capacity, (cfs)

n = Manning's "n"

A = cross-sectional flow area of the pipe (ft.²)

R = hydraulic radius (ft.):

$$R = \frac{A}{P}$$

P = Wetted perimeter (ft); Pipe inside circumference, or (π)(inside diameter) for full flowing pipe conditions

S = pipe slope (feet/foot)

Or, in metric units:

$$Q = \frac{(A)(R^{2/3})(S^{1/2})}{n} \quad \text{Equation 3-1(a)}$$

Where:

Q = pipe capacity, m³/s

n = Manning's "n"

A = cross-sectional flow-area of the pipe (m²)

P = Wetted perimeter (ft); Pipe circumference, or (π)(diameter) for full flowing pipe conditions

R = hydraulic radius (m),

$$R = \frac{A}{P}$$

S = pipe slope (m/m)

For a specific full-flowing pipe installation, the parameters n , A , and R are easily defined constants. The flow-carrying ability, or conveyance factor, of the pipe can then be defined as shown in Equation 3-2 or 3-2(a).

$$k = \frac{(1.486)(A)(R^{2/3})}{n} \quad \text{Equation 3-2}$$

Or, in metric units:

$$k = \frac{(A)(R^{2/3})}{n} \quad \text{Equation 3-2(a)}$$

By substitution, the Manning's formula can then be reduced to the following equation.

$$Q = kS^{1/2} \quad \text{Equation 3-3}$$

Equation 3-3 can also be written as shown in Equation 3-4.

$$k = \frac{Q}{S^{1/2}} \quad \text{Equation 3-4}$$

Direct substitution of design conditions into Equation 3-4 will determine the minimum conveyance factor allowed. Table 3-2 or 3-2 is then used as a guide to select a pipe having a conveyance factor of at least that calculated.

Table 3-1 and 3-2 require knowledge of the Manning's "n" value. These tables can also be used for any materials if the specific Manning's "n" is known.

The Manning's "n" is a critical value in the conveyance concept. Among pipes of the same diameter and slope, Manning's "n" will be the only factor that will have an effect on conveyance, and therefore capacity. When comparing identical field conditions, conveyance has a direct relationship to capacity. That is, if the slope is held constant, tripling conveyance will triple the capacity; halving conveyance will halve the capacity.

Example problems involving conveyance factors are explained in a subsequent section.

Table 3-1
Conveyance Factors (Standard Units)

Design Manning's Values for ADS Thermoplastic Pipe *		
Product	Diameter	Design Manning's "n"
N-12, MEGA GREEN, N-12 STIB, N-12 WTIB, HP STORM, SaniTite, SaniTite HP, N-12 Low Head	4" - 60"	"n" = 0.012
Single Wall Highway and Heavy Duty *	18" - 24" 12" - 15" 10" 8" 3" - 6"	"n" = 0.020 "n" = 0.018 "n" = 0.017 "n" = 0.016 "n" = 0.015
TripleWall and Smoothwall Sewer & Drain	3" - 6"	"n" = 0.009 **
Conveyance Equations: $k = Q/(s^{0.5})$ $Q = k s^{0.5}$		

Conveyance Factors for Circular Pipe Flowing Full																		
		Manning's "n" Values																
Dia. (in.)	Area (sq. ft.)	0.009	0.010	0.011	0.012	0.013	0.014	0.015	0.016	0.017	0.018	0.019	0.020	0.021	0.022	0.023	0.024	0.025
3	0.05	1.3	1.1	1.0	1.0	0.9	0.8	0.8	0.7	0.7	0.6	0.6	0.6	0.5	0.5	0.5	0.5	0.5
4	0.09	2.7	2.5	2.2	2.1	1.9	1.8	1.6	1.5	1.5	1.4	1.3	1.2	1.2	1.1	1.1	1.0	1.0
6	0.20	8.1	7.3	6.6	6.1	5.6	5.2	4.9	4.6	4.3	4.1	3.8	3.6	3.5	3.3	3.2	3.0	2.9
8	0.35	17.5	15.7	14.3	13.1	12.1	11.2	10.5	9.8	9.2	8.7	8.3	7.9	7.5	7.1	6.8	6.5	6.3
10	0.55	31.6	28.5	25.9	23.7	21.9	20.3	19.0	17.8	16.8	15.8	15.0	14.2	13.6	12.9	12.4	11.9	11.4
12	0.79	51.5	46.3	42.1	38.6	35.6	33.1	30.9	28.9	27.2	25.7	24.4	23.2	22.1	21.1	20.1	19.3	18.5
15	1.23	93.3	84.0	76.3	70.0	64.6	60.0	56.0	52.5	49.4	46.7	44.2	42.0	40.0	38.2	36.5	35.0	33.6
18	1.77	151.7	136.6	124.1	113.8	105.0	97.5	91.0	85.3	80.3	75.9	71.9	68.3	65.0	62.1	59.4	56.9	54.6
21	2.41	228.9	206.0	187.3	171.6	158.4	147.1	137.3	128.7	121.2	114.4	108.4	103.0	98.1	93.6	89.6	85.8	82.4
24	3.14	326.8	294.1	267.3	245.1	226.2	210.1	196.1	183.8	173.0	163.4	154.8	147.0	140.0	133.7	127.9	122.5	117.6
27	3.98	447.3	402.6	366.0	335.5	309.7	287.6	268.4	251.6	236.8	223.7	211.9	201.3	191.7	183.0	175.0	167.8	161.0
30	4.91	592.5	533.2	484.7	444.3	410.2	380.9	355.5	333.3	313.7	296.2	280.6	266.6	253.9	242.4	231.8	222.2	213.3
33	5.94	763.9	687.5	625.0	572.9	528.9	491.1	458.3	429.7	404.4	382.0	361.9	343.8	327.4	312.5	298.9	286.5	275.0
36	7.07	963.4	867.1	788.2	722.6	667.0	619.3	578.0	541.9	510.0	481.7	456.4	433.5	412.9	394.1	377.0	361.3	346.8
42	9.62	1453.2	1307.9	1189.0	1089.9	1006.1	934.2	871.9	817.5	769.4	726.6	688.4	654.0	622.8	594.5	568.7	545.0	523.2
45	11.04	1746.8	1572.1	1429.2	1310.1	1209.3	1122.9	1048.1	982.6	924.8	873.4	827.4	786.1	748.6	714.6	683.5	655.0	628.8
48	12.57	2074.8	1867.4	1697.6	1556.1	1436.4	1333.8	1244.9	1167.1	1098.4	1037.4	982.8	933.7	889.2	848.8	811.9	778.1	746.9
54	15.90	2840.5	2556.4	2324.0	2130.4	1966.5	1826.0	1704.3	1597.8	1503.8	1420.2	1345.5	1278.2	1217.4	1162.0	1111.5	1065.2	1022.6
60	19.63	3762.0	3385.8	3078.0	2821.5	2604.4	2418.4	2257.2	2116.1	1991.6	1881.0	1782.0	1692.9	1612.3	1539.0	1472.1	1410.7	1354.3
72	28.27	6117.3	5505.6	5005.1	4588.0	4235.1	3932.6	3670.4	3441.0	3238.6	3058.7	2897.7	2752.8	2621.7	2502.5	2393.7	2294.0	2202.2

* Corrugated Polyethylene Pipe Association (2000) "Hydraulic Considerations for Corrugated Polyethylene Pipe"

** "Lingedburg, Michael, "Civil Engineer Reference Manual"

Table 3-2
Conveyance Factors (Metric Units)

Design Manning's Values for ADS Thermoplastic Pipe *		
Product	Diameter	Design Manning's "n"
N-12, MEGA GREEN, N-12 STIB, N-12 WTIB, HP STORM, SaniTite, SaniTite HP, N-12 Low Head	100-1500mm	"n" = 0.012
Single Wall Highway and Heavy Duty *	450-600mm	"n" = 0.020
	300-375mm	"n" = 0.018
	250mm	"n" = 0.017
	200mm	"n" = 0.016
	75-150mm	"n" = 0.015
TripleWall and Smoothwall Sewer & Drain	75-150mm	"n" = 0.009 **
Conveyance Equations: $k = Q/(s^{0.5})$ $Q = k s^{0.5}$		

Conveyance Factors for Circular Pipe Flowing Full																		
Manning's "n" Values																		
Dia. (mm)	Area (sq. m.)	0.009	0.010	0.011	0.012	0.013	0.014	0.015	0.016	0.017	0.018	0.019	0.020	0.021	0.022	0.023	0.024	0.025
75	0.004	0.03	0.03	0.03	0.03	0.02	0.02	0.02	0.02	0.02	0.02	0.02	0.02	0.01	0.01	0.01	0.01	0.01
100	0.008	0.07	0.07	0.06	0.06	0.05	0.05	0.04	0.04	0.04	0.04	0.04	0.03	0.03	0.03	0.03	0.03	0.03
150	0.018	0.22	0.20	0.18	0.16	0.15	0.14	0.13	0.12	0.12	0.11	0.10	0.10	0.09	0.09	0.09	0.08	0.08
200	0.031	0.47	0.43	0.39	0.36	0.33	0.30	0.28	0.27	0.25	0.24	0.22	0.21	0.20	0.19	0.19	0.18	0.17
250	0.049	0.86	0.77	0.70	0.64	0.59	0.55	0.52	0.48	0.45	0.43	0.41	0.39	0.37	0.35	0.34	0.32	0.31
300	0.071	1.40	1.26	1.14	1.05	0.97	0.90	0.84	0.79	0.74	0.70	0.66	0.63	0.60	0.57	0.55	0.52	0.50
375	0.110	2.53	2.28	2.07	1.90	1.75	1.63	1.52	1.42	1.34	1.27	1.20	1.14	1.09	1.04	0.99	0.95	0.91
450	0.159	4.12	3.71	3.37	3.09	2.85	2.65	2.47	2.32	2.18	2.06	1.95	1.85	1.76	1.68	1.61	1.54	1.48
525	0.216	6.21	5.59	5.08	4.66	4.30	3.99	3.73	3.49	3.29	3.11	2.94	2.80	2.66	2.54	2.43	2.33	2.24
600	0.283	8.87	7.98	7.26	6.65	6.14	5.70	5.32	4.99	4.70	4.43	4.20	3.99	3.80	3.63	3.47	3.33	3.19
675	0.358	12.14	10.93	9.93	9.11	8.41	7.80	7.28	6.83	6.43	6.07	5.75	5.46	5.20	4.97	4.75	4.55	4.37
750	0.442	16.08	14.47	13.16	12.06	11.13	10.34	9.65	9.04	8.51	8.04	7.62	7.24	6.89	6.58	6.29	6.03	5.79
825	0.535	20.73	18.66	16.96	15.55	14.35	13.33	12.44	11.66	10.98	10.37	9.82	9.33	8.89	8.48	8.11	7.77	7.46
900	0.636	26.15	23.53	21.39	19.61	18.10	16.81	15.69	14.71	13.84	13.07	12.39	11.77	11.21	10.70	10.23	9.81	9.41
1050	0.866	39.44	35.50	32.27	29.58	27.31	25.36	23.67	22.19	20.88	19.72	18.68	17.75	16.90	16.14	15.43	14.79	14.20
1125	0.994	47.41	42.67	38.79	35.56	32.82	30.48	28.45	26.67	25.10	23.70	22.46	21.33	20.32	19.39	18.55	17.78	17.07
1200	1.131	56.31	50.68	46.07	42.23	38.99	36.20	33.79	31.68	29.81	28.16	26.67	25.34	24.13	23.04	22.04	21.12	20.27
1350	1.431	77.09	69.38	63.08	57.82	53.37	49.56	46.26	43.36	40.81	38.55	36.52	34.69	33.04	31.54	30.17	28.91	27.75
1500	1.767	102.10	91.89	83.54	76.58	70.69	65.64	61.26	57.43	54.05	51.05	48.36	45.95	43.76	41.77	39.95	38.29	36.76
1800	2.545	166.04	149.43	135.85	124.53	114.95	106.74	99.62	93.62	87.90	83.02	78.65	74.72	71.16	67.92	64.97	62.26	59.77

* Corrugated Polyethylene Pipe Association (2000) "Hydraulic Considerations for Corrugated Polyethylene Pipe"

** "Lingedburg, Michael, "Civil Engineer Reference Manual"4

3-4 MINIMUM VELOCITY CONSIDERATIONS

Sediment can reduce the capacity of a stormwater pipe over time. In some installations, it may render the pipe useless until the system can be cleaned. This is an expensive, time-consuming undertaking so preventative measures should be taken during design. Sedimentation is of great concern in sewer applications since large, heavy grit may be present.

To minimize potential problems, flow should be maintained at a minimum, or self-cleansing, velocity. A commonly accepted self-cleansing velocity for storm and sanitary sewers is 3 fps (0.9 m/s). In each design, a final check should be performed to compare the expected velocity with the self-cleansing velocity. The design velocity for full-flowing pipes can be *approximated* with Equation 3-5:

$$V = \frac{Q}{A} \quad \text{Equation 3-5}$$

The potential for settling is determined by the specific gravity and diameter of particle, its cohesive properties, flow velocity, and the roughness of the pipe interior. For further discussion on the complexities and variables associated with determining the self-cleansing velocity for a specific pipe diameter and material, refer to ASCE publication No. 60, "Gravity Sanitary Sewer Design and Construction." In some specialized installations where sediment is a known problem it may be wise to perform a soil analysis prior to final drainage design.

3-5 MAXIMUM VELOCITY CONSIDERATIONS

High flow velocity can also create problems if not properly taken into consideration. High velocity is usually considered to be approximately 12 fps (3.7 m/s) but can vary depending on the specific site conditions.

The preferred method of contending with high velocity is to look for opportunities to minimize it, such as reducing the slope of the pipe. If that is not feasible, and many times it is not, the velocity must simply be managed the best way possible.

High velocity, especially if it carries an abrasive effluent, can present durability problems. Over time, the invert of the pipe can wear prematurely. Thermoplastics resist the effects of these rigorous conditions better than many other traditional pipe materials. Additional information specific to the effects of abrasives on many types of pipe materials is provided in the *Durability* section (Section 4) of the Drainage Handbook.

Special consideration should also be given to the conditions at the pipe outlet. High flow velocity can erode the channel where the flow is deposited. Erosion management methods, such as rip-rap, should be considered in these areas.

Another consideration in high velocity applications is managing the momentum of the flow. Changes in flow direction will result in large forces that can cause pipe movement, especially if the pipe size is large, velocity is very high, and the native soil has a low bearing strength. Concrete thrust blocks positioned at areas of flow direction change and sized specifically for the site conditions can be used to control the effects of momentum.

Anchoring systems may also need to be considered when the velocity is high or the slope that the pipe is installed is fairly steep. Anchors keep the pipe from moving down the slope while it is being installed and later due to the energy of the flow. They are an especially important consideration if the native soil is subject for movement or instability. ADS does not produce anchoring systems, but can provide additional information on companies who are experts in this area. For further discussion of steep slope applications, refer to "Steep Slope Installations" in the *Installation* section (Section 5) of the Drainage Handbook.

3-6 LONG TERM PRESSURE CONSIDERATIONS

Most ADS pipe products are intended for gravity flow applications only. Storm drainage products are not recommended for long-term pressure or intermittent pressure flow, including constant head and pumping applications. N-12 Low Head pipe may be suitable for long-term and intermittent pressure flow applications where constant pressure does not exceed 5psi and surge pressure does not exceed 10psi. Contact an ADS sales representative for assistance in selecting a product suitable for the project application.

3-7 CULVERT CONSIDERATIONS

Culverts are typically short relative to a storm sewer system and are classified according to which of the ends controls the discharge capacity. Laboratory tests and field observations indicate two primary culvert flow control conditions: (1) inlet control and (2) outlet control. While inlet or outlet control conditions typically do not exist in storm sewer systems, where a system is controlled by the inlet or outlet, hydraulic head loss due to the entrance or outlet must be taken into account. For this reason, the Manning's formula cannot be the sole method of pipe sizing and selection.

While the theory of energy conservation will closely affect culvert design, no single formula or procedure has been developed to design all culverts, due to the numerous variables involved. True culvert design is, therefore, often an empirical, trial-and-error process.

One common variable used in culvert design, is the Entrance Loss Coefficient (k_e). Entrance Loss Coefficients are highly dependant on the size and shape of the interface between the culvert material and the fluid. For example, a square cut abrupt culvert edge will result in a greater loss coefficient than a culvert with a beveled or rounded edge. In the absence of test data for corrugated polyethylene or polypropylene pipe, corrugated metal pipe with a similar profile and structure can be used to estimate the entrance loss coefficients for ADS thermoplastics. Table 3-3 provides Entrance Loss Coefficients based on available data for common pipe materials and end treatments. Ultimately, the design engineer shall determine the most appropriate value for the entrance loss coefficient to use for the application.

Table 3-3
Entrance Loss Coefficients^{a,b}
(Outlet Control, Full or Partially Full Flow)

Type of Structure and Design of End Treatment	k_e
Pipe, Concrete ^a	
Projecting from fill, square cut end	0.5
Square cut with headwall	0.5
Mitered to conform to fill slope	0.7
Beveled edges, 33.7° bevels	0.2
Socket end of pipe	0.2
Pipe, Corrugated Metal ^a , ADS Thermoplastic ^b	
Projecting from fill (no headwall)	0.9
Square cut with headwall	0.5
Mitered to conform to fill slope	0.7
End-Section conforming to fill slope	0.5
Beveled edges (33.7° or 45° bevel)	0.2

a) Data obtained from U.S. Department of Transportation Federal Highway Administration Hydraulic Charts for the Selection of Highway Culverts⁵

b) ADS thermoplastic pipe is estimated to have coefficients in the range of those found for corrugated metal pipe.

3-8 EXAMPLE PROBLEMS

The following example problems demonstrate use of conveyance factors in sizing application, basic velocity checks, and optional designs.

Example 1

Given: Field conditions stipulate a pipe capacity of 2 cfs and a slope of 0.5%.

Find: The ADS pipe product providing the optimum hydraulic solution.

Solution: It is necessary to use Equation 3-4 to determine the required conveyance for the given conditions. Before substituting the values into the equation, first convert the slope into a value with units of feet/foot as follows:

$$0.5\% = 0.005 \text{ ft/ft}$$

Now substitute values directly into Equation 3-4.

$$\begin{aligned} k &= \frac{Q}{S^{1/2}} \\ &= \frac{2}{(0.005)^{1/2}} \\ &= 28.3 \end{aligned}$$

Refer to Table 3-1 to select the appropriate pipe product having a minimum conveyance of 28.3, based on the respective Manning's "n" value. The most practical solutions are as follows:

12-inch corrugated, smooth interior pipe	k = 38.6
15-inch single wall pipe	k = 38.2

The optimum solution would be the pipe with conveyance most near that calculated. Both the 12-inch corrugated, smooth interior and 15-inch single wall pipes will function in about the same manner because their conveyances are relatively close to that required. Final selection of pipe size and material is made in Example 2.

Example 2

Substituting data from tentatively selected solutions from Example 1 into the velocity formula (Equation 3-5), 12-inch corrugated, smooth interior pipe and 15-inch single wall pipe will yield velocities of 3.5 fps and 2.2 fps, respectively. Therefore, the 12-inch corrugated, smooth interior pipe should be selected to attain a self-cleansing velocity.

Example 3

Given: Field conditions stipulate a pipe capacity of 2 cfs and a slope of 0.5%.

Find: The ADS pipe product providing the optimum hydraulic solution.

Solution: It is necessary to use Figure 3-1 and Figure 3-2 to determine the pipe products

$$0.5\% = 0.005 \text{ ft/ft}$$

Refer to Figure 3-1 to select the corrugated, smooth interior pipe diameter. The intersection of the 0.50% and 2 cfs lines is above the 10" line but below the 12" therefore 12" corrugated, smooth interior pipe products are practical.

Refer to Figure 3-2 to select the single wall pipe product diameter. The intersection of the 0.50% and 2 cfs lines is above the 12" line but below the 15", therefore 15" single wall pipe products are practical.

The optimum solution would be the pipe with the flow capacity at least as great as the required. Both, the 12-inch corrugated, smooth liner and 15-inch single wall pipes will function in about the same manner because their flow capacities are greater than that required. Final selection of pipe size and material is made in Example 4.

Example 4

Substituting data from tentatively selected solutions from Example 4 into Figure 3-1 and Figure 3-2, 12-inch corrugated, smooth interior pipe and 15-inch single wall pipe will yield velocities of approximately 3.6 fps and 2.8 fps, respectively. Therefore, the 12-inch corrugated, smooth interior pipe should be selected to attain a self-cleansing velocity.

3-9 FOOTNOTES

¹Federal Highway Administration, *Hydraulic Design of Highway Culverts (HDS 5), 2nd Edition*, 2001, Pg. 33.

²Federal Highway Administration, *Design Charts for Open-Channel Flow (HDS 3)*, August 1961, Chapter 5.

³Clyde, Calvin G., *Manning Friction Coefficient Testing of 4-, 10-, 12- and 15-inch Corrugated Plastic Pipe*. Utah Water Research Laboratory, Report No. 36, May 1980.

⁴Lingedburg, Michael P.E. Civil Engineer Reference Manual. Belmont, CA: Professional Publications, Inc.

⁵Federal Highway Administration, *Design Charts of Highway Culverts (HDS 5), 2nd Edition*, 2001, Pg. 223.

Durability



4-0 DURABILITY

TABLE OF CONTENTS

- 4-1 Overview of Durability Considerations..... 4-2**
- 4-2 Corrosion 4-3**
 - Chemical Corrosion 4-3
 - Electrochemical Corrosion..... 4-4
 - Stress Crack Resistance 4-4
- 4-3 Erosion 4-5**
 - Combined Erosion and Chemical Corrosion 4-8
 - Oxidation..... 4-10
- 4-4 Other Durability Conditions..... 4-11**
 - Sub-Zero Conditions 4-11
 - High Temperature 4-11
 - Ultraviolet Radiation 4-12
 - Animal Attack 4-13
 - Flammability 4-13
- 4-5 Footnotes 4-14**

Tables

- 4-1 Saskatchewan Research Council Wear Rates..... 4-6
- 4-2 Lane Metal Wear Rates 4-6
- 4-3 Relative Wear Resistance 4-7
- 4-4 California State University Abrasion Results 4-9

Figures

- 4-1 Abrasion Resistance of Pipe and Bends for HDPE and CMP..4-8
- 4-2 Oxidation Cycle4-10

BUYER/USER IS RESPONSIBLE FOR SERVICEABILITY OF THE PRODUCT IN ANY GIVEN APPLICATION. SELLER IS NOT RESPONSIBLE FOR INJURY OR DAMAGE RESULTING FROM IMPROPER INSTALLATION, NONCOMPLIANCE WITH THESE GUIDELINES FOR INSTALLATION OF PRODUCT, OR USE OUTSIDE THE GUIDELINES SET FORTH HEREIN.

4-1 OVERVIEW OF DURABILITY CONSIDERATIONS

In a drainage system, adverse conditions challenging the durability of the materials involved may be found in the soil, air, and effluent. This section covers the three primary durability concerns in non-pressure drainage applications:

- 1) Corrosion,
- 2) Erosion (abrasion) from effluent, and
- 3) Weathering effects such as sub-zero temperatures, freeze/thaw cycles, or exposure to ultraviolet radiation.

In any particular installation, it is quite likely that more than one adverse condition will be present. When this occurs, the rate of material deterioration may be greater than the sum of each problem alone.

Thermoplastic is one of the most durable materials available for drainage applications. Plastics, including polyethylene and polypropylene, are some of the most inert materials in today's storm drainage market. They are also highly resistant to the effects of abrasives and are immune to galvanic corrosion. Unlike metals, such as steel and aluminum, which are affected by the pH and galvanic corrosion. In many cases, corrosion problems are compounded when abrasives are also present.

This section, while discussing corrosion, erosion, and weathering effects on an individual basis, provides suggestions for appropriate materials when a multitude of durability factors are present.

The intent of this information is not to determine the life of materials in a particular installation, but to provide a qualitative means to compare the durability at various conditions. For specific installations located in an environment known to be highly aggressive, the manufacturers of drainage material alternatives should be consulted to ensure the suitability of their products.

4-2 CORROSION

CHEMICAL CORROSION

The initial runoff following the onset of a storm, termed the “first flush,” contains rather high concentrations of road salt, motor oils, fuels, and other compounds that have accumulated on the ground surface since the previous storm. Pollutant concentrations are relatively high during the first flush and then taper off to more diluted levels as the storm progresses.

Chemical corrosion occurs when aggressive chemicals in the effluent, individually or in combination, attack the pipe. In some installations, it may be the soil environment, not the effluent, that causes the corrosion. In either situation, the end result is a pipe with reduced strength and, in some cases, negative effects on hydraulic capabilities.

Pipe materials react differently under chemically corrosive environments. Individual states often make recommendations on environments where specific products can be used based on their past performance. Soil environments fluctuate widely making it nearly impossible to offer blanket statements about product suitability throughout the country.

Polyolefins, such as high density polyethylene (HDPE) and polypropylene (PP) are stable materials. Polyethylene and polypropylene have been extensively tested with many potentially corrosive chemicals with few chemicals having any effect on the material. Of those chemicals that were not acceptable, fewer still could be expected in a storm sewer in sufficient concentrations and at a high enough temperature to create problems even on a rather long-term basis. For further information regarding chemical resistance of polyethylene and polypropylene, and additional considerations when evaluating applications, refer to Technical Notes 4.01: *Chemical Resistance of Polyethylene and Elastomers* and 4.02: *Chemical Resistance of Polypropylene and Elastomers*.

Gasket material must also be considered for projects where abnormal chemicals or abnormal concentrations of chemicals are present. Like many common stormwater and sanitary sewer pipe materials, ADS storm and sanitary sewer products utilize gaskets manufactured to meet the requirements of ASTM F477. In most cases, this gasket material is resistant to many of the common chemicals found in storm sewer systems. However, there are chemicals, which may negatively affect the gasket material, such as high concentrations of hydrocarbons. In environmental conditions where a standard gasket material is not suitable, ADS may be able to provide alternative gasket materials to meet the needs of most project requirements. For further information regarding chemical resistance of gasket materials, refer to Technical Note 4.01: *Chemical Resistance of Polyethylene and Elastomers* or 4.02: *Chemical Resistance of Polypropylene and Elastomers*. There is no material difference between the gaskets provided on polyethylene and polypropylene products, but elastomer chemical resistance charts are

provided in both technical notes for ease of reference when researching polyethylene or polypropylene materials.

ELECTROCHEMICAL CORROSION

Electrochemical, or galvanic, corrosion can occur when metals having differing electrical qualities are in direct or indirect contact in the presence of electrical current. Corrosion can occur between entirely different metals or even between areas on the same pipe having different electrical properties. It can also occur between the pipe and its environment.

Stray electrical currents in the soil encourage galvanization. This is especially true where, in larger metropolitan areas, power generation stations, subway systems, or buried electrical transmission lines provide a good source of stray electrical current. Nearby pipe may pick up these currents and create the environment for galvanic corrosion to occur at an accelerated rate.

Metals with good conductivity, namely steel and iron, are most prone to galvanic corrosion. The advanced stages of galvanic corrosion show as a pitting of the pipe wall and as relatively harmless rust deposits. The end result of the problem is a gradual weakening of the structural integrity of the pipe and a lessening of its hydraulic qualities.

Several methods are available to prevent or reduce the rate of galvanic corrosion although, depending on the environment, they may prove to be rather costly solutions. One alternative uses blocks of “sacrificing” metals, such as zinc or magnesium, in contact with the pipes. These materials corrode at a faster rate than the pipe allowing the pipe to remain relatively free of corrosion. The sacrificing metal block must be checked routinely and periodically replaced in order for the system to work properly.

Another method of preventing corrosion is to coat the metallic pipe with a material that cannot support electrical activity. Polymers and asphalt materials are often used for this purpose.

A third alternative is to install a material that is unable to support galvanic corrosion, such as thermoplastics like polyethylene, polypropylene and PVC. Thermoplastics are unable to carry electrical current and therefore do not require precautions such as coatings or sacrificing metal blocks. Thermoplastics provide a cost-effective drainage alternative immune to electrochemically corrosive environments.

STRESS CRACK RESISTANCE

The durability of a material directly impacts structural performance. For HDPE pipe, the stress-crack resistance of critical structural members must be accurately assessed to determine the long-term implications on the pipe and installation integrity. Service life, therefore, directly impacts structural integrity and provides the basis for requiring materials to meet

or exceed the specified performance life of the facility, which in many cases approaches 100 years.

To verify the base material has adequate stress capacity for a given application, the base HDPE material is subjected to a Notched Constant Ligament Stress (NCLS) test. Both of the industry accepted national standards for corrugated polyethylene pipe used in storm drainage applications, ASTM F2306, AASHTO M294, as well as the Canadian Standards Association CSA B182.8 and Bureau de Normalisation du Quebec BNQ 3614-120, specifically require a 24-hour NCLS test to be conducted on the base polyethylene material used in pipe production.

In addition to the NCLS test on the base resin, the service life of dual wall corrugated HDPE pipe has historically been assessed based on stress cracking at the pipe's inner liner and corrugation wall interface¹. Although this circumferential cracking is easy to observe and assess, it does not represent a critical structural component of the pipe. The fact that one could remove the entire inner liner of a dual wall corrugated HDPE pipe and not influence its structural performance is evidence of the error of basing a service life on such a non-critical component. The highest tensile stress locations of buried corrugated HDPE pipe occur in the outer most fiber of the corrugation, where the bending strains are the greatest. Compression related strains do not result in any long-term stress cracking, so one must concentrate on tensile strains. These tensile bending strains are associated with deflection, which is a key AASHTO design parameter. The stress-crack resistance of these corrugation members under bending strains, therefore, reflects the critical structural components to evaluate for stress-crack resistance².

For applications encountering continuous pressure, high peak pressures, or extreme applications resulting in high induced stresses, HDPE materials with a higher NCLS value or an HDB pressure rated material may be required. Contact ADS engineering for additional guidance on these types of applications.

Polypropylene, while similar in many others aspects, is not similar to polyethylene with respect to stress cracking. Polypropylene has a significantly higher stress crack resistance and is therefore not susceptible to cracking at the same magnitudes at which HDPE may crack.

4-3 EROSION

The amount of stones, grit, and other debris (abrasives) found in a storm sewer vary with the drainage installation. The velocity of or frequency with which the abrasive materials occur is also unpredictable. It is for these reasons that laboratory data representative of field conditions have been nearly impossible to generate. Much of what the industry currently knows about the effects of abrasives on the life of pipe has been

discovered through visual inspections of existing systems and the reputation of well-established drainage products.

Laboratory tests are valuable, however, for developing relative wear rates. The Saskatchewan Research Council conducted a laboratory investigation on several materials to quantify the degree of wear that could be expected from abrasives applied in a controlled fashion. The Council compared a series of 2-inch (50mm) pipes, including polyethylene, steel, and aluminum. The abrasives included coarse sand (30 mesh) and fine sand (48 mesh). Each was used in a 40 percent by weight slurry and applied at a controlled temperature and velocities to a closed-loop system. The test ran three weeks at 15 fps (4.6 m/s) and six weeks at 7 fps (2.1 m/s). Material loss was then measured. Wear was assumed to be evenly distributed over the interior of the surface so that gouging, if it did occur, was not measured. Results from the study for velocities of 15 fps (4.6 m/s) were extrapolated to obtain wear rates on an annual basis as shown in Table 4-1.

Table 4-1
Saskatchewan Research Council Wear Rates³

Material	Wear Rates (mm/yr)			
	Coarse Sand (30 mesh)		Fine Sand (48 mesh)	
	@ 7 fps	@ 15 fps	@ 7 fps	@ 15 fps
Steel	0.65	1.81	0.04	0.2
Aluminum	1.81	7.48	0.14	0.86
Polyethylene	0.06	0.46	nil	0.06

Lane Metal performed an abrasion resistance test in 1982 on several PVC pipes and Class III reinforced concrete pipe. The tests simulated an extremely harsh environment by filling a length of pipe with a stone/water slurry and sealing each end with a watertight cap. The pipes were placed on a rocker arm and rocked 45 degrees from the horizontal. Wear on the pipes was inspected on a daily basis and additional stone was added to maintain the abrasiveness. Following the 91 hour test, thickness measurements were taken along the path of heaviest wear. Results of the Lane metal test are shown in Table 4-2.

Table 4-2
Lane Metal Wear Rates⁴

Material	Wear, 10 ⁻³ in/hr (10 ⁻³ mm/hr)
PVC	0.3 (7.6)
RCP	0.9 (22.9)

Some means of correlating Tables 4-1 and 4-2 was needed to be able to compare the results of both tests. As a similar thermoplastic, PVC and polyethylene could be expected to behave much the same, and it was this assumption that was used to further the investigation.

A study was performed in 1975 by a team of Swedish scientists dealing with the effects of mechanical cleaning methods on polyethylene and PVC pipe. Both materials were about equal in performance with polyethylene outperforming PVC at times, and PVC outperforming

polyethylene in other instances. It was concluded that PVC and polyethylene are approximately equal in abrasion resistance.

In each of the three laboratory tests reviewed, the pipes under study were subjected to an environment that was harsher than they would probably experience in an actual installation. Laboratory testing could also not account for the increased rate of corrosion and/or abrasion that would occur on steel and concrete pipes after the first few resilient layers had been removed.

While test data for polypropylene is less extensive due to its previously limited use in drainage applications, two types of tests were conducted to determine polypropylene's abrasion resistance and provide a means for a relative comparison to other pipe materials.

One test placed high density polyethylene and polypropylene plaques in a closed-conduit system with water flow carrying abrasive sand going over the plaques in order to determine the mass loss over time. Results indicated that while polypropylene performed slightly better than high density polyethylene, both materials performed well and have comparable abrasion resistance.

The second test, performed by Polymer Diagnostics, Inc., used the Taber abrasion method where rotating abrading wheels were placed in direct contact with the material to create a rub-wear action. Results provide a mass loss of the sample. The Taber test included HDPE, PP and PVC samples. The HDPE and PP samples had minimal percent mass loss. While the PVC samples had a slightly higher percent mass loss, it can be concluded that all three materials have comparable abrasion resistance.

Based on the results from both these tests, polypropylene is comparable to HDPE and PVC as it relates to abrasion resistance of the pipe materials. A full summary of these test methods and the results are available in Technical Note 4.03: *Abrasion Resistance of Thermoplastic Material*.

The results of all tests discussed so far, while not able to be compared directly, are highly valuable when comparing wear rates in relative terms. The wear rates of the materials were compared to those of the toughest materials, thermoplastics including polyethylene and polypropylene, to obtain relative wear resistance as shown in Table 4-3.

Table 4-3
Relative Wear Resistance

Polyethylene	10
Polypropylene	10
PVC	10
RCP	3
CSP	3
CAP	1

Tests conducted by Schreiber and Hocheimer to determine the effects of bends on the relative wear rates indicate a wear resistance for HDPE that is approximately four times better than the wear resistance of steel.

These tests were conducted with both 7% and 14% by volume quartz sand to water mixtures, with an average flow rate velocity of 23 fps. Figure 4-1 illustrates the results from this study.

Figure 4-1
Abrasion Resistance of Pipe and Bends for HDPE and CMP⁵

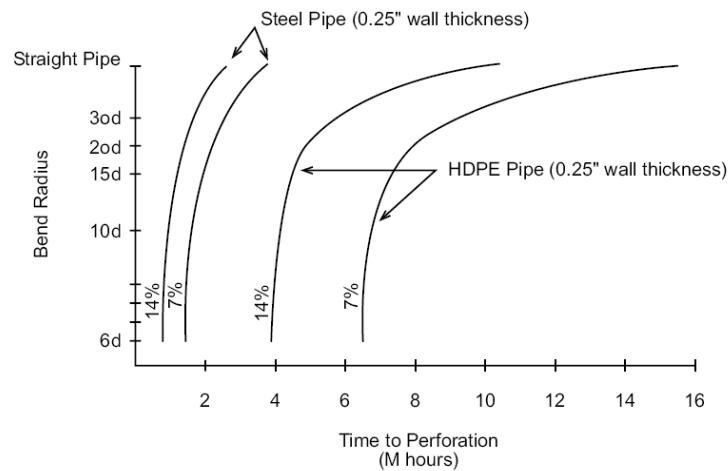

COMBINED EROSION AND CHEMICAL CORROSION

When more than one adverse condition is present in a pipeline, the effects of both combine to form an environment with the potential to drastically shorten the design life. Acids or alkalis in combination with abrasives, acids in combination with freeze/thaw cycles, or abrasives in combination with freeze/thaw cycles are just a few of the combinations that can be present in an installation.

Acids and abrasives in combination are often present in storm drainage networks and were therefore selected as subjects in a study performed at California State University⁶. This combination was previously known to have a great deal of impact on concrete products, so the main focus of the study was on concrete and how it compared to polyethylene. Again, knowing polyethylene and polypropylene are both in the polyolefin group of plastics, their wear resistance is generally considered comparable where polypropylene will behave similarly to polyethylene under the same conditions.

A rocker-type mechanism was also used in the California State research. A "cycle" consisted of one end of the pipe swinging through an 83 degree arc and was completed in about ten seconds. A total of 100,000 half-cycles (50,000 complete cycles) were used in the tests.

For the abrasive materials a crushed quartz [1/2-inch to 3/4-inch (13-19mm)] and river run quartz gravel [2-inch (51mm) minimum] were selected. In order to reasonably simulate an installation, 2/3 of the abrasives were crushed quartz with the remainder being the river run gravel. Velocity of the gravel/fluid slurry through the pipe length was

timed at 3 fps (0.9 m/s). Midway through the test the aggregate was examined for wear and it was determined that the abrasive should be recharged.

Tests were run in both a chemically neutral environment (pH 7.0) and with a moderately strong acid (pH 4.0). The acidity of the circulating fluid was checked at frequent intervals and adjusted, if necessary, with acetic acid. Controlling the acidity was especially important for the concrete pipe because of its tendency to raise the pH as a result of its alkaline composition.

Twelve-inch (300mm) HDPE smooth interior polyethylene pipe was tested with the results showing that the abrasive/acid slurry had an almost negligible effect when compared to the results of the abrasives in a neutral environment. In the neutral environment the maximum abrasion was 0.021-inches (0.5mm). The polyethylene allowed just 14 percent more abrasion along the invert in the acidic environment.

The results for the 12-inch (300mm) non-reinforced concrete pipe were quite different. In a neutral environment, wear along the invert was approximately 0.80-inch (20.3mm). The addition of acid to the slurry increased this wear nearly 90 percent. Had a reinforced pipe been used, the steel would have been exposed thereby creating a third durability issue, galvanic corrosion, as well as structural concerns from reduced wall strength.

Table 4-4
California State University Abrasion Results

	Effluent	
	pH = 7.0 w/ abrasives	pH = 4.0 w/ abrasives
12" Polyethylene	0.021" (0.53mm)	0.023" (0.58mm)
12" Non-reinforced Concrete	0.80" (20.3mm)	1.52" (38.6mm)

NOTE: None of the aforementioned tests in this section are intended to determine the life of any drainage pipe. In all cases, the tests simulated extremely harsh environments on a constant basis. It would be in error to extrapolate any wear rates presented, compare them with the pipe wall thickness, and then assign a life to the pipe in a typical drainage application.

These test results are intended to provide guidelines to compare the relative durability of some of the most popular drainage materials on the market today. Product life is dependent on many factors including wall thickness and exact material composition; size, shape, frequency, and velocity of abrasives; soil and effluent pH and composition; and the ability of the soil, effluent, and pipe to support galvanic corrosion.

The life of some of these materials can be improved by the addition of liners or coatings to reduce the effects of the abrasion or corrosion on the base material.

Further complicating the process of calculating the service life of materials is determining when the pipe is rated as “failed.” Understanding the failure mode and the associated structural, hydraulic, and durability issues created at the failure point is as important as understanding the life of the product itself.

OXIDATION

Oxidation is the process by which a polymer, such as polyethylene or polypropylene, first absorbs energy through heat, UV exposure or other methods. This first step in the reaction excites polymer molecules and creates radicals within the material. These radicals react with oxygen causing more radicals to form. Where oxidation occurs, the material can become more susceptible to stress cracking as the material molecular weight decreases causing the material to become more brittle or soften. As stated by Tisinger and Giroud⁷, oxidation will continue until the radicals interact with antioxidants, recombine, or when the energy source is removed.

Oxidation of polymers has been studied for a number of years through the gas pipe, geomembrane, and hot water pressure pipe industries. The result of this work, shown in Figure 4-2, clearly shows the onset of the mechanical property degradation is well beyond the design life of the product where an appropriate antioxidant and good stress crack resistance is present.

Figure 4-2
Oxidation Cycle

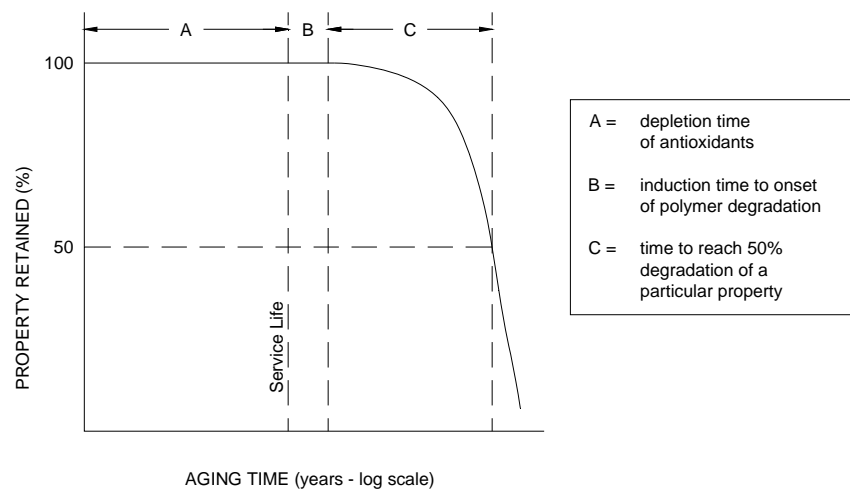

Source: Hsuan¹ (2003)

4-4 OTHER DURABILITY CONDITIONS

SUB-ZERO CONDITIONS

Bitter cold conditions can make some plastic drainage products brittle. This results in difficult installations due to the precautions that must be taken to avoid damaging the pipe. This is particularly true of PVC which can become extremely brittle in freezing and sub-zero conditions. Industry standards typically test HDPE at temperatures of 4°C or lower while PVC is predominantly tested at ambient temperatures. While polypropylene can withstand temperatures slightly below freezing, to avoid susceptibility to cracking, the working temperature should not fall below 0°F (-17 C). The minimum working temperature of polyethylene is around -40°F (-40 C).

While, polyethylene can endure continuous freezing temperatures without brittleness or any additional precautions in the installation, caution should be used when working with PVC or polypropylene at low temperatures. Metals and concrete are not affected by cold conditions.

HIGH TEMPERATURE

The combination of direct sunlight and high ambient temperatures can cause black polyethylene to absorb heat, although generally not to the extent that will affect installation or performance of the pipe. Generally, the maximum working temperature for both polyethylene and polypropylene pipe is 140°F (60°C), but is also dependent on the chemicals in the liquid carried. For any plastic, an increase in temperature reduces stiffness; a decrease in temperature increases stiffness.

A test was conducted in 1992 to determine the impact of high temperature on polyethylene pipe. The test, conducted during a clear day with temperatures in the low 80 degrees F (mid 20 C), involved putting a salamander space heater into a 36-inch (900mm) diameter smooth interior polyethylene pipe and raising the temperature of the outside of the pipe to 140° F (60°C). The pipe was then backfilled and compacted to approximately 95% standard Proctor density to the top of the pipe. The heater was then turned off and seven feet (2.1m) of loose clay soil was added. The measured vertical deflection increased 4% immediately after the backfill operation and then decreased 1% from that value after the load was placed. This test represents an extreme condition, but nonetheless validates that high temperatures do not significantly affect the handling or installation of polyethylene pipe. As the pipe cools to the temperature of its soil environment, the original stiffness characteristics will return.

The coefficient of thermal expansion for polyethylene is 6.5×10^{-5} inch/inch length/degree F. Generally, this means the pipe changes 0.078-in per 100-ft length of pipe for each degree F. Polypropylene has a slightly lower coefficient of thermal expansion of 5.0×10^{-5} inch/inch length/degree F,

with an upper limit value closer to that of polyethylene. The means polypropylene may change 0.06-in per 100-ft length of pipe for each degree F, or more. While the two materials have comparable expansion coefficients, the light grey color of ADS HP polypropylene pipe will have lower light absorption (thus lower heat conversion) when exposed to sunlight compared to black polyethylene.

Where there is a large temperature differential between the pipe and the installed condition, such as pipe stored on the ground in full sunlight then immediately placed in a trench and backfilled, lateral movement from thermal contraction is restrained by the backfill. This lateral restraint can result in impacting longitudinal stresses in the pipe wall. Additionally, if shrinkage were to occur in a longitudinal direction, the result could be joints opening as the pipe cools. Due to the coefficient of thermal expansion for polyethylene and polypropylene, precautions against longitudinal shrinkage should be taken in applications where there is an extreme temperature differential between the pipe and the surrounding conditions. This is especially critical in above-ground installations.

ADS Triple Wall small diameter product has a titanium dioxide additive to make the exterior of the pipe white in color. By reflecting much of the solar heat, extreme temperature differentials within the pipe wall and around the circumference are eliminated. Maintaining consistent temperatures eliminates warping of the pipe during storage at the job site. Titanium dioxide is especially important to prevent warping in the more rigid long lengths of Triple Wall, but it also protects these products from exposure to ultraviolet radiation, discussed further in the following material.

ULTRAVIOLET RADIATION

A certain segment of the sunlight spectrum, ultraviolet (UV) radiation, can cause unprotected plastic materials to degrade over time. In an effort to reduce these effects, ADS incorporates a high quality UV stabilizer and antioxidant package into all polyethylene and polypropylene products to protect any portion that is exposed to the sun. In polyethylene, a minimum content of 2% carbon black is required by ASTM D3350 for weather resistant grades. Carbon black is an excellent UV stabilizer and has a proven track record in the telecommunications and automobile industries. Polypropylene products incorporate an outdoor, weatherable pigment system plus a Hindered Amine Light Stabilizer, or HALS, to produce a pipe resistant to UV radiation over the life of the product. Ongoing testing being conducted in Florida, Arizona, and Ohio, shows no degradation in physical or rheological properties of the pipe after a year of direct exposure to sunlight. Titanium dioxide is added to ADS Triple Wall products to both protect the pipe from UV radiation and reflect sunlight to maintain a consistent temperature.

With the UV stabilizers incorporated into polyethylene and polypropylene, the radiation can only penetrate a thin layer into the pipe wall over the service life of the pipe. The amount of additive protects the pipe from UV damage for typical on-site storage periods in addition to the inventory

storage time accounted for at the factory. It is important to understand that once the outer layer has been faded by the sun, it functions as a shield to protect the rest of the pipe from further degradation. A high percentage of the pipe's original strength properties remain intact because the majority of the wall remains unharmed. Thus, even the exposed ends of large diameter culverts remain structurally sound.

All thermoplastics, including PVC, are likewise affected by ultraviolet radiation. Metals and concrete pipes are not affected.

It is also important to realize that UV is only an issue during the time the pipe is exposed to sunlight. Following installation, UV radiation is no longer an issue for any thermoplastic product.

ANIMAL ATTACK

Neither polyethylene nor polypropylene attracts or act as a nutrient for animals. As with any pipe material, rodents will gnaw through pipe if it acts as a barrier to food or water, but the occurrence is rare. Currently, no known microbes attack polyethylene or polypropylene.

FLAMMABILITY

While the risk of fire occurring in storm or sanitary sewer pipe systems is very limited, there are applications involving culverts or outfall structures where fire may potentially occur. In these applications where fire does occur, nearly all pipe materials can be affected under the right conditions. The National Fire Protection Association (NFPA 704) has given both polyethylene and polypropylene a rating of 1 (Slow Burning) on a scale of 0 to 4, where higher ratings indicate a greater vulnerability. A report published by the Florida Department of Transportation entitled *High Density Polyethylene Pipe Fire Risk Evaluations* states "HDPE pipe is not at significant risk of fire when installed to present standards and exposed to fire such as that may be encountered in roadside grass fires".

The natural gas industry has utilized polyethylene pipe, in diameters up to 18 in., for more than 30 years without reported problems. Polypropylene is commonly used for cold and hot water distribution lines, among other uses, and has seen growing use internationally for years. For areas where flammability is of extra concern, all pipe materials can be protected with the use of inflammable end treatments such as the use of Rip-rap, gravel, or concrete headwalls around exposed ends.

4-5 FOOTNOTES

¹Hsuan, Grace (2003). "Laboratory Tests to Evaluate Crack Free Service Life of HDPE Corrugated Pipes." Florida DOT Materials Report.

²Kurdziel, John M., P.E. and Palermo, Eugene F., PhD., "Stress Crack Resistance of Structural Members in Corrugated High Density Polyethylene Pipe," (Transportation Research Board, 2007).

³Haas, D.B. and Smith, L.G., *Erosion Studies*, Saskatchewan Research Council, E75-7, Sept. 1975.

⁴Lane Metal Products Co., Inc., *Plastic Bore Corrugated Steel Pipe Test Program*, 1983.

⁵Schreiber, W., and Hocheimer, M., "Vergleichende Verschleißversuche an Stahl- und Hostalen-Rohren sowie Gummischläuchen mit Durchstromenden Sand-Wasser-Gemisch", Bericht Nr. 681042, Frankfurt: Hoechst AG, 1968.

⁶Corrugated Plastic Tubing Association, *Abrasion Resistance of Polyethylene and Other Pipes* (Sacramento, CA, 1989).

⁷Tisinger, L.G. & Giroud, J.P. (1993). *The Durability of HDPE Geomembranes*. Geotechnical Fabrics Report.

Installation



5-0 INSTALLATION

TABLE OF CONTENTS

- 5-1 Overview of Installation Considerations..... 5-3**
- 5-2 Pre-Installation Storage and Handling 5-4**
- 5-3 Line and Grade 5-5**
- 5-4 Trench Excavation..... 5-5**
- 5-5 Backfill Envelope Construction 5-7**
 - Backfill Material..... 5-8
 - Backfill Placement 5-12
 - Compaction..... 5-16
 - Mechanical Compaction Equipment..... 5-16
- 5-6 Joints 5-18**
 - N-12[®] Plain End (soil-tight couplers)..... 5-18
 - N-12[®] ST IB (gasketed soil-tight couplers) 5-18
 - N-12[®] WT IB (gasketed watertight couplers)..... 5-19
 - HP Storm (gasketed watertight couplers)..... 5-19
 - SaniTite[®] (gasketed watertight couplers)..... 5-19
 - SaniTite[®] HP (gasketed watertight couplers) 5-19
 - N-12[®] Low Head (gasketed watertight couplers) 5-19
- 5-7 Other Installation Considerations..... 5-21**
 - Construction and Paving Equipment..... 5-21
 - Joining Different Pipe Types or Sizes..... 5-22
 - Field Connections 5-22
 - Curvilinear Installations..... 5-22
 - Manhole and Catch Basin Connections 5-23
 - Vertical Installations 5-23
 - Groundwater 5-24
 - Flotation 5-24
 - Parallel Pipe Installations..... 5-26
 - Steep Slope Installations 5-27
 - Cambered Installations..... 5-27
 - Sliplining..... 5-28
 - Post-Construction Inspection..... 5-28
- 5-8 Appendix A-5 5-30**
 - Other Technical Resources 5-33

Figures

- 5-1 Typical Subtrench Installation..... 5-7
- 5-2 Typical Backfill Structure 5-13
- 5-3 Rammer Compactors 5-16
- 5-4 Static Compactors 5-17
- 5-5 Vibrating Compactors 5-17
- 5-6 Minimum Pipe Spacing 5-26
- 5-7 Cambered Pipe Installations..... 5-28

Tables

5-1 Minimum Trench Widths.....5-5

5-2 Classes of Embedment and Backfill Materials5-10

5-3 General Recommendations for Installation and
Use of Soils & Aggregates5-15

5-4 Compaction Equipment Selection Guide.....5-18

5-5 Guidelines for Joint Performance Selection.....5-20

5-6 Temporary Cover Requirements for Light Construction Traffic...5-21

5-7 Bending Radii for ADS Thermoplastic Pipe.....5-23

5-8 Approximate Weight of ADS Thermoplastic Pipes5-25

5-9 Minimum Cover Required to Prevent Flotation.....5-26

A-5-1A Available Product-Specific Technical Literature &
Detail Drawings.....5-30

A-5-1B Available (U.S.) Product-Specific Technical Literature & Detail
Drawings.....5-30

A-5-2A Minimum Installation Requirements for ADS
Thermoplastic Products (U.S.).....5-31

A-5-2B Minimum Installation Requirements for ADS
Thermoplastic Products (Canadian).....5-32

BUYER/USER IS RESPONSIBLE FOR SERVICEABILITY OF THE PRODUCT IN ANY GIVEN APPLICATION. SELLER IS NOT RESPONSIBLE FOR INJURY OR DAMAGE RESULTING FROM IMPROPER INSTALLATION, NONCOMPLIANCE WITH THESE GUIDELINES FOR INSTALLATION OF PRODUCT, OR USE OUTSIDE THE GUIDELINES SET FORTH HEREIN.

5-1 OVERVIEW OF INSTALLATION CONSIDERATIONS

Installation of ADS pipe is in most respects very much like that of any quality pipe installation. The strength of a pipe system shall be considered a combination of the pipe itself and the backfill envelope. Proper construction maximizes the drainage capabilities designed into the pipe by maintaining alignment and load-carrying ability.

Recommendations for proper backfill and installation for ADS products are based primarily on the requirements of ASTM D2321 "Recommended Practice for Underground Installation of Flexible Thermoplastic Sewer Pipe", CSA B182.11-11 "*Standard Practice for the Installation of Thermoplastic Drain*", and BNQ 1809-3 "*Construction Work-General Technical Specification- Drinking Water and Sewer Lines*". These handbooks are not intended to replace standard industry or project specifications, but to provide guidance based on our experience, research and recommendations for proper product performance.

The elements regarding backfill that are addressed in this section are as follows:

Proper backfill material selection - A variety of materials can be used as structural backfill with the final decision, many times, based on what is most available locally. Native soil may be an appropriate material providing it meets the basic criteria established in this section.

Proper backfill compaction - Compaction forces out air and moisture to provide a more stable structure. Minimum compaction levels are based on the material characteristics and the design load; some situations may require the use of mechanical compactor while others require simply tamping the material to eliminate voids.

Proper backfill structure - An adequate quantity of structural backfill is necessary to ensure adequate support. Undisturbed native soil from a trench wall often provides additional support. Typical trench dimensions and the effect of the trench wall are discussed in this section.

In addition, this section discusses job-site handling, trench construction and pipe installation for ADS products, compaction methods, and several specialized installation considerations.

Federal regulations covering safety for construction are published in the Safety and Health Regulations for Construction under the Department of Labor, Occupational Safety and Health Administration (OSHA). These regulations define practices, which must be followed.

5-2 PRE-INSTALLATION STORAGE AND HANDLING

Thermoplastic pipes such as polyethylene and polypropylene are lightweight and easy to use. While no special care is needed in handling and installation a few precautions should be set forth.

- Follow all applicable safety regulations when handling pipe.
- The pipe shall not be dropped from the delivery truck into an open trench, or onto uneven surfaces.
- Avoid dragging or striking the pipe against another pipe or object.
- Avoid dragging the pipe across the ground.
- Avoid any impact to the bell or spigot.
- Do not drive over the pipe prior to installation.
- Inspect the pipe and joining systems before installation.
- Care shall be taken to not over handle the pipe during assembly.

Many ADS drainage products are available palletized allowing for convenient transporting and orderly storage. If the products were not received on a pallet, the pipe should be carefully stacked. One method commonly used is to secure the bottom lengths of pipe together side-by-side, or use stop blocks, and then place additional pipe on top. Where pipe is stock piled, the total pile height shall not exceed 5-feet and the pipe must be adequately restrained to prevent pile collapse. Do not walk on stock piled pipe. Additional handling and storage information is available upon request.

Ambient temperature extremes do not affect the strength or handling characteristics of ADS pipe products. Cold temperatures can affect the impact resistance of some thermoplastics, although polyethylene and polypropylene remain highly impact resistant. In-house quality checks on polyethylene products demonstrate that the impact resistance at zero degrees F (-18C) is many times that required by specification. Additionally, hot weather, especially when coupled with direct sunlight, will raise the pipe temperature, but will not significantly affect handling or installation behavior.

Depending on the product, either carbon black or another UV stabilizer is added to the polyethylene or polypropylene to protect against ultraviolet light; unprotected plastic can become less impact resistant over time. Such additives are required by the specification and protect the pipe during storage periods at the manufacturing facility and at the job site. Ultraviolet light is no longer an issue after installation.

Long-term exposure to ultraviolet light causes slightly different results. The UV stabilizer protects the pipe for several years, after which the impact strength of the exposed layer, generally 0.001-inch (0.03mm), is significantly reduced. This damaged layer then functions in shielding the remainder of the pipe wall from any further damage. There are HDPE

culverts, currently under observation, that were installed in 1974. The culverts have retained nearly all of their original strength characteristics and support strong evidence of continued service.

5-3 LINE AND GRADE

Storm drain and sewer pipe systems are designed to provide hydraulic capacity based on pipe size and slope. The alignment or line of the pipe is the horizontal location of the pipe while the grade is the vertical slope of the pipe. In order for a pipe system to function as designed, it is important to install the pipe to the proper line and grade.

Generally, no special practices are required to maintain line and grade; however, certain installation techniques can greatly increase the system performance and rate of installation.

Alignment is established by a field survey. Once the trench is excavated on line, the pipe bedding shall be placed to proper thickness. The top of the bedding shall be adjusted to allow for the difference between the plan invert (flowline) and pipe profile wall thickness. To determine the dimension to be subtracted from the pipe inverts indicated on the plans when checking bedding elevations measure the distance from the interior side of the liner to the crown of the corrugation.

5-4 TRENCH EXCAVATION

The width of the trench depends on the pipe diameter, backfill material, and the method of compaction. Trenches that are too narrow will not allow for proper pipe installation, whereas trenches that are overly wide are unnecessarily costly. As a practical matter, standard bucket sizes may also factor into the decision. The design engineer may modify the trench widths based on an evaluation of the competency of the in-situ materials, the quality and compaction level of the backfill, the design loads and the compaction equipment to be used. In lieu of the engineer's recommendations or governing agency specifications, the following trench widths are suggested in table 5-1.

Table 5-1
Minimum Trench Widths

Nominal Pipe Diameter, in. (mm)	Minimum Trench in. (m)	Nominal Pipe Diameter, in. (mm)	Minimum Trench in. (m)
4 (100)	21 (0.5)	24 (600)	48 (1.2)
6 (150)	23 (0.6)	30 (750)	56 (1.4)
8 (200)	26 (0.7)	36 (900)	64 (1.6)
10 (250)	28 (0.7)	42 (1050)	72 (1.8)
12 (300)	30 (0.8)	48 (1200)	80 (2.0)

15 (375)	34 (0.9)	54 (1350)	88 (2.2)
18 (450)	39 (1.0)	60 (1500)	96 (2.4)

Trench widths should only be wide enough to permit the adequate placement and compaction of the embedment materials. This ideal trench width is normally referred to as the minimum trench width. It is designated in accordance with national standards and generally assures the width allows for backfill material to flow on either side of the pipe and permits the compaction of this material. If the width is not sufficiently wide for the materials and proposed compaction methods a wider trench allowing for proper installation shall be constructed.

In very poor native soils (for example; peat, muck, or highly expansive soils), a wider trench width with possibly filter fabric may be required. This wider trench width shall be based on an evaluation of the in-situ soil, and the design and construction loads.

Trench widths for pipe are often determined by the bucket size available for the excavator. In many cases, the bucket width can significantly exceed the ideal trench width. Wide trenches are not only costly to excavate and fill with backfill material they actually reduce the structural integrity of the pipe/backfill system. This fact is noted in the AASHTO *LRFD Bridge Construction Specification*, Section 30, "Trenches shall be kept to the specified width as any increase in trench width will increase the load on the pipe."

Years of consolidation create a very stable soil environment. The desire is to destroy as little of that stability as necessary when digging the trench. Stable trench walls actually enhance the structural integrity of the system when the trench is relatively narrow. Overly wide trenches also require more backfill material and more compaction which are typically not as stable as the undisturbed native material. A stable trench wall is characterized as one that can stand without support; however this does not refer to the possible need of trench wall supports to comply with OSHA.

It should be noted that although the pipe will have less load in a narrow trench condition, a wide trench application is used for the design methodology for thermoplastic pipe found in *AASHTO LRFD Bridge Design Specifications* Section 12. This point is clearly illustrated in Section 12.12, "narrow trenches yield a desirable level of conservatism, since the transfer of the load to in-situ trench wall is not considered in flexible pipe design."

The depth of the trench is dictated by the geography of the site and the pipe slope required. However, if an adequate foundation for the pipe is not available at the desired depth, additional excavation will be needed. Rock outcroppings, muck, and other unsuitable materials do not provide proper support. They shall be removed and replaced with suitable granular material. Refer also to Figure 5-1.

Trenching shall be completed in existing soils with sidewalls reasonably vertical to the top of the pipe. For positive projection embankment

installations, the embankment material shall be placed and compacted to a minimum of one (1') foot above the pipe and the trench excavated into the embankment. When excavation depths or soil conditions require shoring or use of a trench box, the bottom of the shoring or trench box should be placed no lower than the top of the pipe. This prevents disruption of the backfill envelope when removing the shoring or trench box. Dragging the trench box shall only be done if it does not damage the pipe or disrupt the backfill, otherwise, the box shall be lifted vertically into its new position. If this practice cannot be followed, consideration should be given to leaving the shoring in place. When the trench box must be located below the top of the pipe, the most effective way to maintain a sound system is to provide a 'sub trench' within which to place the pipe and backfill. For safety, the bottom of the trench box should not be greater than 24" above the bottom of the trench. For more information on the use of trench boxes, refer to Technical Note 5.01: *Recommended Use for Trench Boxes*.

Figure 5-1
Typical Sub Trench Installation

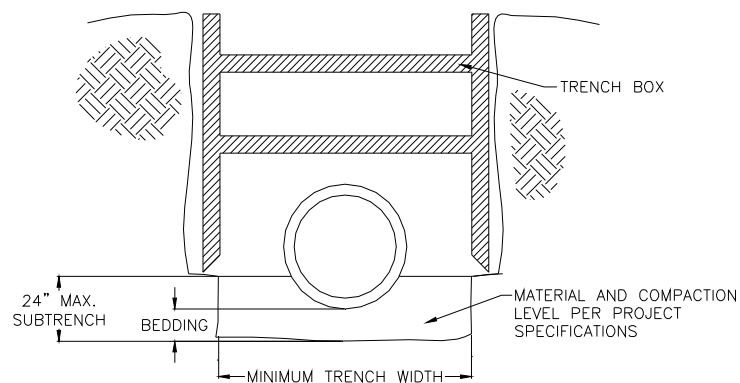

5-5 BACKFILL ENVELOPE CONSTRUCTION

Backfill construction shall be evaluated as part of the structural design of polyethylene and polypropylene pipe like it is for other pipe materials. ASTM D2321/ CSA B182.11-11 serve as the basis for installation recommendations in trafficked installations. Acceptable backfill materials and construction methods are very similar or, in many cases, identical to those required for other types of pipe material.

The primary purpose of the backfill envelope is to provide long-term support to the pipe. In a properly constructed backfill envelope, the loads are distributed across the crown of the pipe to the material along the sides and then to the pipe bedding and foundation. This load arching effect reduces the total load applied to the pipe.

The load that a flexible pipe will carry is related to the backfill envelope construction. The load-carrying capacity of a pipe/backfill system will be

determined by a combination of the backfill material, the level of compaction, and the placement of the backfill material. However, the type of application may also influence what type of backfill is required. These and other related issues are discussed in subsequent paragraphs in this section.

BACKFILL MATERIAL

Material selection is the first and most important step to creating a structurally sound backfill envelope. In general, backfill material should be of an aggregate nature, able to be compacted, if necessary, into a structurally sound structure. A variety of materials, including some native soils, meet these requirements.

Backfill offers passive resistance, termed the “modulus of soil reaction”. The modulus of soil reaction is determined by a combination of the material and the amount of compaction. The type of material (sand, gravel, clay, etc.) and compaction level (standard Proctor density) determine overall strength of the backfill. Some research indicates that other factors, such as the beneficial effects of trench walls, may add to the conservancy of the backfill strength, although those relationships are often neglected. (This information assumes the trench walls are at least as strong as the backfill material.)

The strength of the backfill can be described using different parameters. One way is by describing it in terms of the modulus of soil reaction (E'), which is an empirical value developed by the Bureau of Reclamation to calculate deflection. Another parameter used to describe backfill strength is the secant constrained soil modulus (M_S). Values for M_S and E' are discussed further in the Structures chapter of this handbook.

Recommendations for soil type and compaction level will vary based on the application and product; Appendix A-5 provides product-specific guidelines and literature references. Shallow, non-trafficked installations may not require the same level of backfill quality, but any modifications should be discussed with ADS engineers prior to establishing backfill criteria on a particular project. Installations involving higher loads sometimes require a higher soil strength; ADS engineers can also provide additional guidance on backfill requirements in these situations.

As discussed in the Structures section of this handbook, it is the combination of the type of material and compaction level that will determine the soil strength. When a variety of options will work in a particular installation, the final decision can depend on what is most available locally in order to keep the cost of the installation to a minimum. Native soil may be specified depending on the ADS product being installed, the application and when following the requirements of Table 5-2 and the respective technical literature as listed in Appendix A-5. Using native soil eliminates the cost of imported backfill material and the effort spent grading or hauling the excavated material off site. If the native material is not acceptable, then appropriate material will need to be brought in.

Flowable fill, also known as controlled low strength material (CLSM), controlled density fill (CDF) and slurry fill, is another, more specialized, type of backfill material that is increasing in use throughout the country. This material is a mixture of soil, cementitious material, and water. With acceptable in-situ material, flowable fill trench widths can be reduced. Although the structural integrity of flowable fill is excellent, it will misalign or float the pipe unless precautions, such as weighting the pipe or pouring the flowable fill in lifts, are taken. For more information on the use of flowable fill refer to Technical Note 5.02: *Flowable Fill Backfill for Pipe*.

Table 5-2
Classes of Embedment and Backfill Materials

ASTM D2321 ^(A) (CSA B182.11) Class Description		ASTM D2487 Notation Description		AASHTO O M43 Notation	AASHTO M145 Notation	BNQ 2560	ASTM D2321 ^(A) (CSA B182.11)								
							Percentage Passing Sieve Sizes				Atterberg Limits		Coefficients		
							1 ½ in. (40mm)	3/8" (9.5mm)	No. 4 (4.75mm)	No. 200 (0.075 mm)	LL	PI	Cu	Cc	
I ^(B)	Crushed rock, angular ^C	N/A	Angular crushed stone or rock, crushed gravel, crushed slag; large voids with little or no fines	5, 56, 57 ^(D) , 6, 67 ^(D)	N/A		100%	≤25%	≤15%	<12%	Non Plastic		N/A		
II	Clean, coarse-grained soils	GW	Well-graded gravel, gravel-sand mixtures; little or no fines	5, 6	A1, A3	CG-14, MG-20	100%		<50% of "Coarse Fraction"	<5%	Non Plastic	>4	1 to 3		
		GP	Poorly-graded gravels, gravel-sand mixtures; little or no fines	56, 57, 67								<4	<1 or >3		
		SW	Well-graded sands, gravelly sands; little or no fines									>6	1 to 3		
		SP ^F	Poorly-graded sands, gravelly sands; little or no fines									<6	<1 or >3		
	Coarse-Grained Soils, borderline clean to w/fines	GW-GC, SP-SM	Sands and gravels which are borderline between clean and with fines	N/A				100%		Varies	5% to 12%	Non Plastic	Same as for GW, GP, SW and SP		
III	Coarse-grained soils with fines	GM	Silty gravels, gravel-sand-silt mixtures	Gravel & sand with <10% fines	A-2-4, A-2-5, A-2-6, or A-4 or A-6 soils with more than 30% retained on #200 sieve	100%		<50% of "Coarse Fraction"	12% to 50%	N/A	<4 or <"A" Line	N/A			
		GC	Clayey gravels, gravel-sand-clay mixtures								<7 & >"A" Line				
		SM	Silty sands, sand-silt mixtures								>4 or <"A" Line				
		SC	Clayey sands, sand-clay mixtures								>7 & >"A" Line				
	Inorganic fine-grained soils	ML	Inorganic silts and very fine sands, rock flour, silty or clayey fine sands, silts with slight plasticity						100%	> 30% (Retained)	<50		<4 or <"A" Line		
		CL	Inorganic clays of low to medium plasticity; gravelly, sandy, or silty clays; lean clays						> 30% (Retained)	>7 & >"A" Line					
IV ^(E)	Inorganic fine-grained soils	ML	Inorganic silts and very fine sands, rock flour, silty or clayey fine sands, silts with slight plasticity	N/A	A-2-7 or A-4 or A-6 soils with 30% or less retained on #200 sieve	100%	100%	< 30% (Retained)	<50	<4 or <"A" Line	N/A				
		CL	Inorganic clays of low to medium plasticity; gravelly, sandy, or silty clays; lean clays	N/A				>7 & >"A" Line							
V ^(S)	Inorganic fine-grained soils	MH	Inorganic silts, micaceous or diatomaceous fine sandy or silty soils, elastic silts	N/A	A5, A7	100%	100%	>50%	>50	<"A" Line	N/A				
		CH	Inorganic clays of high plasticity, fat clays	N/A						>"A" Line					
	Organic soils or Highly organic soils	OL	Organic silts and organic silty clays of low plasticity	N/A						100%		100%	>50%	>50	<4 or <"A" Line
		OH	Organic clays of medium to high plasticity, organic silts	N/A											<"A" Line
		PT	Peat and other high organic soils	N/A											

Notes:

- A) Refer to ASTM D2321 / CSA B182.11/ BNQ 2560 for more complete soil descriptions.
- B) Class I materials allow for a broader range of fines than previous versions of D2321 / B182.11. When specifying class I material for infiltration systems, the engineering shall include a requirement for an acceptable level of fines.
- C) All particle faces shall be fractured.
- D) Assumes less than 25% passes the 3/8" sieve.
- E) Class IV materials require a geotechnical evaluation prior to use and should only be used as backfill under the guidance of a qualified engineer.
- F) Uniform fine sands (SP) with more than 50% passing a 100 sieve behave like silts and should be treated as Class III soils if allowed.
- G) Class V materials shall not be permitted as bedding and backfill material.

Backfill Placement

Storm and sanitary sewers, as well as drainage lines are sometimes placed on foundations that settle and shift in a non-uniform manner. Fortunately, flexible pipe can accommodate many of these changes without detrimental effects. The best construction practices, however, involve placing the pipe on a firm foundation for maximum performance and structural integrity throughout the design life.

In some cases it may be necessary to perform subsurface evaluations of the soil conditions where muck, rock, or other unsuitable conditions are suspected. Zones of soft material, such as muck, allow the pipe to settle, potentially affecting the structural integrity and hydraulic characteristics of the system. Rock and rock protrusions apply point loads where they contact the pipe that can affect the hydraulics or structural integrity of the system. It is recommended that unsuitable foundation material be excavated before installation of the pipe proceeds. Where a rock or unyielding or soft foundation is present, the design engineer or a geotechnical engineer shall be consulted to determine the extent to which the undesirable material is to be excavated.

Bedding

If no undesirable foundation material is found, a minimum of 4- to 6-inches (0.1 - 0.15m) of bedding shall be placed and compacted on the foundation to equalize load distributions along the invert of the pipe. Refer to Figure 5-2 for a pictorial description of backfill terminology.

A stable and uniform bedding shall be provided for the pipe and any protruding features of its joints and/or fittings. The middle of the bedding, under the pipe invert, equal to 1/3 of the pipe O.D. should be loosely placed, with the remainder compacted to minimum standard proctor density as listed in Appendix A, Table A-5-2. The same class of material recommended for the initial backfill is suitable for the bedding; however, the compaction requirements for the bedding may be higher than compaction requirements for the initial backfill to ensure the stability of line and grade. Refer to Appendix A-5, Table A-5-2 for product-specific installation recommendations for each zone.

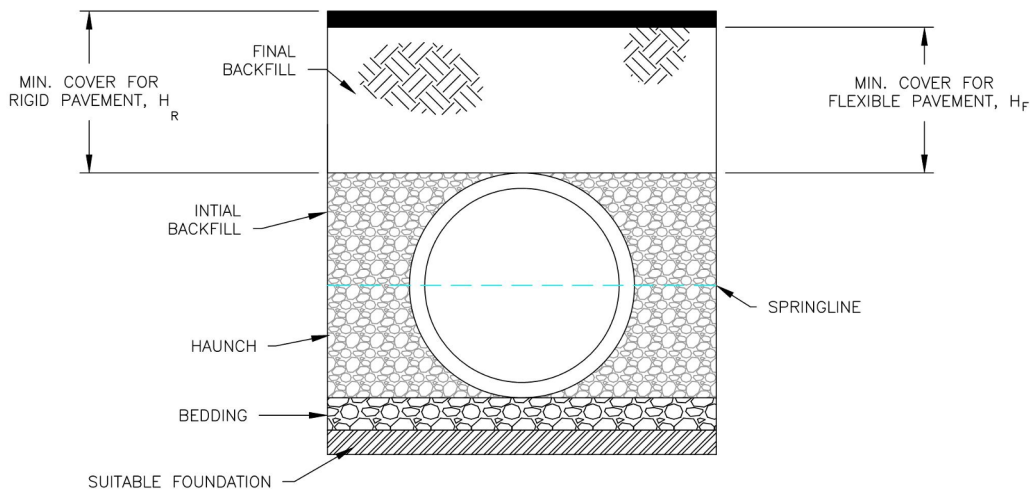

Note: Where using open-graded material (class I with little fines for example) in any fill zone, additional precaution must be taken to reduce or eliminate the risk of migration of fines from adjacent material. Precautionary steps could include the use of geotextile between the varying fill materials, gradation selection to prevent the migration of fines, or other precautionary measures. Refer to ASTM D2321 / CSA B182.11 for more complete information.

**Figure 5-2
Typical Backfill Structure**



$H_R, H_F = 12"$ (0.15m) FOR PIPE DIAMETERS UP TO 48" (1200mm)
 $= 24"$ (0.6m) FOR PIPE DIAMETERS 54" (1350mm) AND 60" (1500mm)

BEDDING = 4" (100mm) MIN

 FILL AS SPECIFIED BY DESIGN ENGINEER
 STRUCTURAL BACKFILL (SEE NOTE)

STRUCTURAL BACKFILL
 SEE TABLE A-5-2 OR APPENDIX A-5 FOR MATERIAL AND COMPACTION REQUIREMENTS BASED ON PIPE MATERIAL AND APPLICATION

Haunch Backfill

The next layer of backfill, the haunching, is the most important since it is this layer that provides the pipe with support against the soil and traffic loadings. Haunching shall be placed in lifts of 4- to 6-inches (0.10 - 0.15m) and compacted in accordance with product specific guidelines listed in Appendix A-5, Table A-5-2 to achieve required depth of fill. Construction of each lift should be repeated up to the spring line.

Initial Backfill

Initial backfill extends from the spring line to the crown of the pipe. This area of the backfill anchors the pipe and ensures that loads are distributed as evenly as possible into the haunching. The same material used in the haunching shall be used for the initial backfill. Where differing materials are used, backfill material size should be selected as to prevent migration of fines or a geosynthetic shall be used to separate the backfill zones. Additionally, it is crucial to obtain similar backfill strength between fill zones if differing materials are used. Using the same material throughout the embedment zone is recommended for all ADS products; however, using different materials between the haunch and initial backfill zones may be accomplished under strict guidelines that are outlined in the appropriate product's fill height table technical note. See Table A-5-1 for a list of fill height table technical notes.

When using a material that requires compaction it is important not to use mechanical compaction equipment directly on the pipe itself. Initial backfill shall be placed in lifts of 4- to 6-inches (0.10 - 0.15m) and compacted in accordance with product-specific guidelines in Appendix A-5, Table A-5-2 to achieve required depth of fill. Tamp to achieve the specified compaction, or shovel into the area, eliminating voids, if the material doesn't require mechanical compaction. Construction of each lift should be repeated until the initial backfill zone is completed.

Flowable fill can be used throughout the pipe zone as an alternative to compacted granular material, however special precautions are necessary for a successful installation. Flowable fill may cause the pipe to float or misalign. Therefore the pipe will need to be weighted with sandbags or held with some type of anchoring system. The flowable fill may also be poured in layers that are allowed to cure before the next layer is poured to help reduce the tendency for the pipe to float. As with any backfill material, proper installation of the flowable fill around the pipe is critical to the structural performance of the pipe. For additional information on the use of flowable fill, refer to Technical Note 5.02: *Flowable Fill Backfill for Pipe*.

Final Backfill

Final backfill, which extends from the initial backfill layer to the ground surface, does not directly support the pipe. Excavated materials may be of adequate quality for final backfill, depending on the intended use at the surface. Selection, placement and compaction of final backfill shall be as directed by the design engineer. When placing final backfill, consideration needs to be given to compaction equipment and construction loads operating over top of the pipe. Proper compaction of the final backfill area is not nearly so critical for the pipe as in the other layers; however, if roads or drives will be crossing the pipe, a relatively high degree of compaction is needed to prevent pavement settlement.

Minimum Cover

For traffic applications total minimum cover is 12-inches (0.3m) for single run applications for 4- to 48-inch (100mm-1200mm) diameters pipe. For 54- and 60-inch (1350mm and 1500mm) diameter pipe total minimum cover is 24-inches (0.6m) for single run applications. Total minimum cover is measured from top of pipe to bottom of flexible pavement or to top of rigid pavement.

When no pavement will be installed, but vehicle traffic is expected (e.g. gravel driveway), a total minimum cover of 18-inches (0.5m) for 4- to 48-inch (100-1200mm) diameters and 30-inches (0.8m) for 54- and 60-inch (1350mm and 1500mm) diameters is recommended to minimize rutting. If the ground surface is truly green space or a landscape area, minimum cover may be 12-inches (0.3m) from top of pipe to ground surface for all diameters. These recommendations assume the pipe is installed in accordance with manufactures recommendations and may not address the cover needed to prevent flotation.

Table 5-3
General Recommendations for Installation and Use of Soils and Aggregates¹

Backfill Zone	Class 1	Class 2	Class 3 ²
General Restrictions	Acceptable and common where no migration is probable or when combined with a geotextile filter media.	Where hydraulics gradient exists check gradation to minimize migration.	Do not use where water condition in trench may cause instability and/or prevent proper placement and compaction..
Foundation	√ Suitable as foundation and for replacing over-excavated and unstable trench bottoms as restricted above and as directed by design engineer.	√ Suitable as foundation and for replacing over-excavated and unstable trench bottoms as restricted above and as directed by design engineer.	√ Suitable as foundation and for replacing over-excavated and unstable trench bottoms as restricted above and as directed by design engineer.
Bedding	√ - 4" for 12"-24" pipe 6" for 30" to 60" pipe - Loosely place middle 1/3*OD with remainder compacted	√ - 4" for 12"-24" pipe 6" for 30" to 60" pipe - Loosely place middle 1/3*OD with remainder compacted	√ - 4" for 12"-24" pipe 6" for 30" to 60" pipe - Loosely place middle 1/3*OD with remainder compacted
Haunch	√ - Work in around pipe by hand to provide uniform support - knife in to remove any voids	√ - Work in around pipe by hand to provide uniform support - knife in to remove any voids	√ - Work in around pipe by hand to provide uniform support - knife in to remove any voids
Initial Backfill	√ - knife in to remove any voids	√	√
	For compaction and material recommendations, refer to product-specific guidelines in Appendix A-5, Table A-5-2		
Relative Compaction Effort	Low	Moderate	High
	For compaction and material recommendations, refer to product-specific guidelines in Appendix A-5, Table A-5-2		
Final Backfill	√ - Place and compact as required by the engineer	√ - Place and compact as required by the engineer	√ - Place and compact as required by the engineer

√ = Material may be suitable. Ultimately, the design engineer must determine the acceptable backfill material based on specific project conditions and structural requirements for the product.

- 1) Refer to Table 5-2 for more complete soil requirements.
- 2) Class 3 is not recommended for all products. Refer to Appendix A-5, Table A-5-2A & B for product-specific recommendations.

COMPACTION

The level of compaction will vary depending on the material and installation requirements, see product specific guidelines in Appendix A-5, Table A-5-2 for minimum compaction requirements based on soil type and application. Crushed stone or similar materials are usually not compacted, but do require care during installation to eliminate large voids in the backfill envelope. Using a shovel to 'slice' or 'knife' the material under and around the pipe is many times sufficient.

For other materials, compaction methods will depend primarily on the amount of compaction, or modulus of soil reaction, required and the moisture level of the material. At optimum moisture levels, some Class II and III soils can be compacted to minimum recommended levels simply by walking on each backfill lift. While this technique may not be acceptable for all installations, the point is that compaction need not always require a great deal of extra effort or mechanical equipment. If, however, mechanical compaction equipment is needed in the backfill envelope or elsewhere on the site, the subsequent paragraphs provide guidance on compaction equipment and the soils for which they are most appropriate.

MECHANICAL COMPACTION EQUIPMENT

Hand Tampers and Hand-Held Power Tampers: Compaction of the haunch layer may require a small tamping mechanism to obtain the specified compaction in a confined area. A hand-held pole or two-by-four can be used to compact the haunching. Tampers for horizontal layers shall not weigh more than twenty pounds (89N) and the tamping face shall be limited to an area no larger than 6-inch by 6-inch (0.15 by 0.15m).

Rammers or rammer plates (Figure 5-3): Impact action is used to force out air and water from between soil particles to consolidate the fill. This equipment works well on cohesive or high-clay content soils. Care should be taken not to use rammer-type compactors directly on the pipe. For heavy-duty compaction equipment, such as a Ho-pac® or equivalent type compactors, a minimum of 4-feet (1.2m) of backfill shall separate the pipe from the equipment at all times.

Figure 5-3
Rammer Compactors

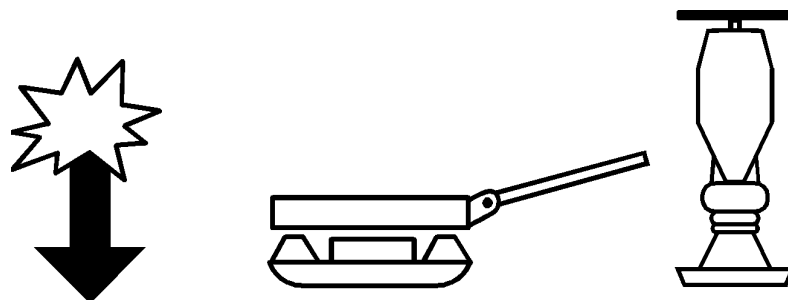

Static Compactors (Figure 5-4): Consolidation with static compactors occurs as a result of the rolling weight of the equipment itself. Sheeps-foot rollers employ projecting feet to concentrate the weight of the machine. Static compactors are most valuable when used on non-cohesive backfill away from the pipe. Other methods of compaction should be used near the pipe.

Figure 5-4
Static Compactors



Vibrating Compactors (Figure 5-5): The motion of vibrating rollers or plates “shake” the soil particles into a more dense arrangement and works best with non-cohesive fills. Depending on the size and weight of the machine, vibrating compactors may be used close to the pipe. As always, care should be taken not to impact the pipe directly with a great deal of force.

Figure 5-5
Vibrating Compactors

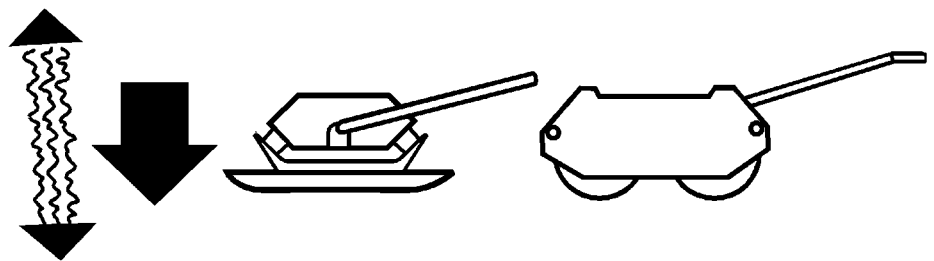

Selecting the right equipment for the fill material is the key to achieving the most efficient compaction. For soil mixtures, the component having the highest percentage will dictate what type of compaction equipment is needed. Table 5-4 provides guidance in the selection of compaction equipment.

**Table 5-4
Compaction Equipment Selection Guide**

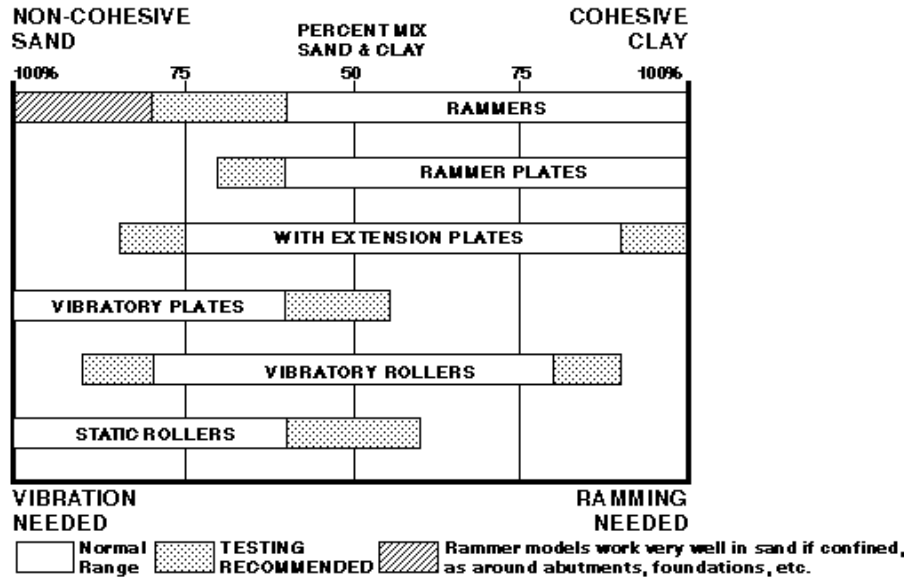

5-6 JOINTS

Joints serve several purposes in a pipe system. Their primary purpose is to preserve the structural integrity by keeping the embedment material out of the system. Well-designed joints also preserve the hydraulic properties of the pipe by maintaining alignment between pipe ends. Joints can keep effluent inside the pipe, which is necessary when environmental issues are a concern. Site-specific requirements or local regulations will usually dictate the performance of joint required. Joint configuration details are available in the respective product specification located in Section 1.

N-12 PLAIN END (SOIL-TIGHT COUPLERS)

ADS N-12 plain end pipe joint use external coupling bands, such as a split band coupler, that meet the soil-tight requirements of AASHTO M252, AASHTO M294, ASTM F2306, CSA B182.8, or BNQ 3624-120. Typically, soil-tight joints are used with perforated systems where soil migration is not a design concern.

N-12 ST IB (GASKETED SOIL-TIGHT COUPLERS)

The N-12 ST IB joining system is designed to perform in demanding soil conditions. The gasket meets all the testing requirements of ASTM F477. The gasket, combined with an interference fit, provides outstanding joint performance meeting or exceeding the soil-tight joint performance requirements of AASHTO M252, AASHTO M294, ASTM F2306, CSA B182.8, or BNQ 3624-120.

N-12 WT IB (GASKETED WATERTIGHT COUPLERS)

The ADS 4- through 60-inch (100mm - 1500mm) N-12 WT IB joint meets the watertight joint performance requirements of AASHTO M252, AASHTO M294, ASTM F2306, CSA B182.8, and BNQ 3624-120. This joint shows no leakage when pressurized to 10.8 psi (74.5 kPa) under the laboratory conditions established in ASTM D3212.

This level of watertightness is recommended for systems that require a very tight joint for normal storm drainage conditions or other site and/or environmental reasons.

HP STORM (GASKETED WATERTIGHT COUPLERS)

The ADS 12- through 60-inch (300mm - 1500mm) N-12 HP meet the watertight joint performance requirements of ASTM D3212. This joint shows no leakage when pressurized to 10.8 psi (74.5 kPa) under the laboratory conditions.

This level of watertightness is recommended for systems that will be pressure tested, or that require a very tight joint for other site and/or environmental reasons.

SANITITE (GASKETED WATERTIGHT COUPLERS)

The ADS 24- through 60-inch SaniTite joint meet the watertight joint performance requirements of AASHTO M252, AASHTO M294, ASTM F2306, CSA B182.8, and BNQ 3624-120. This joint shows no leakage when pressurized to 10.8 psi (74.5 kPa) under the laboratory conditions established in ASTM D3212.

This level of watertightness is recommended for systems that will be pressure tested to sanitary sewer standards, or that require a very tight joint for other site and/or environmental reasons. A longer bell design and two gaskets are used for SaniTite pipe.

SANITITE HP (GASKETED WATERTIGHT COUPLERS)

The ADS 12- through 60-inch SaniTite HP joint meet the watertight joint performance requirements of ASTM D3212. This joint shows no leakage when pressurized to 10.8 psi (74.5 kPa) under the laboratory conditions established in ASTM D3212.

This level of watertightness is recommended for systems that will be pressure tested to sanitary sewer standards, or that require a very tight joint for other site and/or environmental reasons. A longer bell design and two gaskets are used for SaniTite HP pipe.

N-12 LOW HEAD (GASKETED WATERTIGHT COUPLERS)

The ADS 24- through 60-inch (600mm - 1500mm) N-12 Low Head IB joint meet the watertight joint performance requirements of AASHTO M252, AASHTO M294, and ASTM F2306. This joint shows no leakage when pressurized to 10.8 psi (74.5 kPa) under the laboratory conditions established in ASTM D3212.

This level of watertightness is recommended for systems that will be under continuous pressures less than 5psi and surge pressures of 10psi or that require a very tight joint for other site and/or environmental reasons. A longer bell configuration with two gaskets is used for N-12 Low Head pipe.

Guidelines for deciding what joint performance is appropriate in a particular application are provided in Table 5-5.

Table 5-5
Guidelines for Joint Performance Selection

Project Conditions	Joint Performance Options				
	Soil Tight		Water Tight		
	N-12 Plain End (4"-30")	N-12 ST IB Gasketed (4"-30")	N-12 WT IB (4"-60")	HP STORM SaniTite or SaniTite HP (12"-60")	N-12 Low Head (24"-60")
SOIL FACTORS					
Potential for small or negligible soil migration (e.g., gravel, medium to coarse sands, cohesive soil).	√	√	√	√	√
Potential for moderate soil migration (e.g., fine sands, silts).	N/R	√	√	√	√
Potential for severe soil migration (e.g., very fine sands, non-cohesive fines).	N/R	N/R	√	√	√
EFFLUENT CONDITIONS					
Effluent is permitted to infiltrate into ground; poses little or no environmental concern.	√	√	√	√	√
Effluent has potential to cause groundwater or other contamination.	N/R	N/R	√	√	√
PRESSURE CONDITIONS					
Installation will operate under non-pressure conditions.	√	√	√	√	√
Installation will operate under non-pressure conditions; minimized leakage desired.	N/R	√	√	√	√
Installations with low temporary pressures due to operational events and ASTM D3212 joint quality required. Installed system to be hydrostatic pressure tested with an associated leakage allowance.	N/R	N/R	√	√	√
Installations with continuous pressure (≤5psi) or frequent surge pressure (≤10psi)	N/R	N/R	N/R	N/R	√

√ The most restrictive of the project conditions will ultimately determine minimum joint quality. Ultimately, the design engineer must determine the acceptable joint quality for the project.

N/R Not recommended by manufacturer. Final approval contingent on design engineer.

Where more than one product or joint design will be acceptable in a particular installation, the most cost effective alternative should be selected. Bell-and-spigot joints shorten installation duration and reduce

labor because they require little time and effort to assemble; the result can be significant overall cost savings.

5-7 OTHER INSTALLATION CONSIDERATIONS

Not all drainage projects can be considered “typical” installations. Unusual soil conditions cannot always be found until the actual excavation is made. More complicated pipe configurations may be needed to arrive at the desired drainage pattern or to increase the capacity of an existing drainage network. ADS cannot anticipate all situations encountered on specific installations; however, several common questions are answered in the following material. Contact the ADS Applications Engineering Department or visit our website at www.ads-pipe.com for answers to other unique conditions.

CONSTRUCTION AND PAVING EQUIPMENT

Some construction vehicles, such as many types of paving equipment, are not as heavy as the design load. For situations with relatively light construction vehicles, the minimum cover criteria discussed in Section 2: *Structures* can be decreased during the construction phase; however, rutting may still occur at the surface. Table 5-6 presents the surface applied loads and the corresponding minimum cover that can be permitted on a temporary basis. *These criteria should only be employed during construction; finished projects should always meet minimum cover requirements for the anticipated final-use loading conditions. Vehicles exceeding criteria in Table 5-6 must not be permitted to drive over the installation.*

Table 5-6
Temporary Cover Requirements for Light Construction Traffic

Type of Vehicle	Vehicular Load at Surface, psi(kPa)	Temporary Minimum Cover, in (mm) for:	
		4"-48" (100mm-12mm) Pipe	54"-60" (1350mm-1500mm) Pipe
Semi-tractor ¹	75 (517)	9 (230)	12 (300)
Loaded pick-up truck ²	50 (345)	6 (150)	9 (230)
Skid steer loader ³	25 (172)	3 (80)	6 (150)

1. Based on typical 3-axel day-trip tractor without trailer.

2. Chevy® 3500 Series, fully loaded

3. Bobcat® T180 Model skid steer loader

Very heavy construction traffic poses additional concern for buried flexible pipe when buried at shallow depths. The extremely high loads created by construction vehicles can potentially reduce the safety factors below reasonable levels in minimum cover conditions. It is recommended that three feet (0.9m) of cover be used over the pipe in installations involving construction vehicles between 30T and 60T (267-534kN). For heavier vehicles a greater amount cover is required. The amount of cover is dependent on the load and loading footprint. This additional cover can

simply be mounded and compacted over the pipe during the construction phase and then graded following construction. If, in a particular installation the pipe already has minimum amounts of cover, no additional precautions are needed.

JOINING DIFFERENT PIPE TYPES OR SIZES

Drainage systems often involve connecting pipe of different materials or sizes. Options to make these transitions are often limited by the joint quality required. One very common method of connecting different types of pipe of the same size, and in some cases different sizes, is through the use of a concrete collar. This generally provides a minimum silt-tight joint quality but ultimately depends on workmanship. A concrete collar is formed by butting the two pipe ends together, wrapping the junction with a geotextile to keep out most soil and concrete, and then pouring a concrete collar that covers both pipe ends.

Another option may be using fittings or adapters specifically designed for this application. ADS offers a selection of fittings designed to make the transition from one material directly to another. In other cases an ADS fitting may need to be used in combination with another manufacturer's gasket to complete the transition. Transitions made in this manner may be more watertight than a concrete collar.

FIELD CONNECTIONS

Field connections may be necessary to complete pipe runs for short pipe lengths or for repairs to pipe damaged during construction. Field connections and repairs should be performed with couplers compatible to the overall system. See Technical Note 5.03, 5.12 and 5.13 for *Thermoplastic Pipe Repair Options* for more details on field cuts and connections.

CURVILINEAR INSTALLATIONS

ADS pipe can be laid on a curved alignment as a series of tangent (straight sections) deflected horizontally at each joint. However, the amount of joint articulation is dependent on the type of joint selected. See Table 5-7 for minimum bend radii based on joint type.

**Table 5-7
Bend Radii for ADS Thermoplastic Pipe**

Pipe Diameter, In (mm)	Joint Type	Maximum Deflection at Joint (deg)	Radius, ft (m), per pipe length		
			10 ft (3m)	13 ft (4m)	20 ft (6m)
4 – 36 (100 – 900)	N-12 (split band or bell-bell couplers)	3	191 (58)	248 (76)	382 (116)
42 – 60 (1050 – 1500)	N-12 (split band or bell-bell couplers)	1.5	382 (117)	497 (152)	764 (233)
4 – 24 (100 – 600)	N-12 ST IB or N-12 WT IB (bell & spigot)	1.5	n/a	497 (152)	764 (233)
30 – 60 (750 – 1500)	N-12 ST IB or N-12 WT IB (bell & spigot)	1	n/a	745 (227)	1146 (349)
12 – 60 (300 – 1500)	HP STORM, SaniTite, SaniTite HP or Low Head, (extended bell & spigot)	3	n/a	248 (76)	382 (116)

Bend radii calculated with joint articulations only. Calculations do not assume any bend in the pipe wall. Joint deflections based on joint profiles and accounts for possible field variances.

MANHOLE AND CATCH BASIN CONNECTIONS

Manholes and catch basins can be more costly than other alternatives but also allow grade and directional changes in addition to changes in pipe material and size. Consideration shall be given to the project performance specified when selecting manhole connections. For connection options, refer to Appendix A, Table A-5-1 for list of list of technical literature associated with the appropriate product.

VERTICAL INSTALLATIONS

ADS thermoplastic pipe is sometimes installed vertically for use as catch basins or manholes, meter pits, and similar applications. Vertical installations do not behave the same as pipe that is installed horizontally because the pipe/soil interaction is different. The soil surrounding a vertical pipe locks into the corrugations, allowing the pipe to move along with the soil consolidation that occurs over time. This movement can cause a rippling of the interior liner that generally does not affect the performance of the finished installation.

Installation requirements are especially important for vertical installations. Backfill material and compaction levels will determine the performance of the finished installation. Backfill shall extend a minimum of one-foot (0.3m) completely around the vertical structure. Only Class 1 or 2 backfill material is recommended and should be compacted to minimum 90% SPD.

Additional general applications limits include the following:

- Height of the vertical structure must not exceed eight feet (2.4m), unless the design is reviewed by the ADS Application Engineering Department.

- If traffic will be driving over a vertical structure, a concrete collar or similar structure designed to transmit the load into the ground must be used. Traffic loads must *not* be transmitted directly into the pipe wall.
- Cast iron frames holding grates or lids must be seated on a concrete collar or similar structure so that the weight of the frame and grate or lid is transferred into the ground, *not* to the vertical pipe.

Vertical installations of any ADS fitting should first be reviewed for suitability with ADS Application Engineering. This includes, but is not limited to, tees, elbows, and reducers of any combination. Improper application or inadequate installation may affect the function of the part or the drainage system. There may also be other product performance limits depending on the application. Contact ADS for further information.

GROUNDWATER

Excessive groundwater hinders proper placement and compaction of bedding and backfill. ADS thermoplastic pipe will float in standing water; therefore, it is imperative that a dry trench be provided. In order to insure a stable trench bottom, the water level in the trench shall remain below the bedding during the installation procedure. It may be necessary to provide sump pumps, well points, deep wells, geofabrics, underdrains or a diversion ditch to insure a dry trench. The project engineer shall be consulted to determine appropriate dewatering methods given specific project conditions.

FLOTATION

Pipe of any material and size can float under the right conditions. The soil type and density, amount of cover, height of the water table, pipe weight, and the amount of effluent in the pipe will all have an effect on the flotation potential.

The pipe property affecting flotation is its weight where heavier products are not as likely to float. One of the primary installation benefits of ADS polyethylene pipe is its light weight. The same quality that provides easy handling and installation also provides it with a greater opportunity to float. Table 5-8 gives approximate weights by inside diameter for ADS thermoplastic pipes.

Table 5-8
Approximate Weight of ADS Thermoplastic Pipes

Inside Diameter in (mm)	Approximate Weight* lb/ft (kg/m)		
	Single Wall	Dual Wall	Triple Wall
4(100)	0.31 (0.46)	0.44 (0.65)	N/A
6(150)	0.58 (0.86)	0.85 (1.3)	N/A
8(200)	1.2 (1.8)	1.5 (2.2)	N/A
10(250)	1.8 (2.7)	2.3 (3.4)	N/A
12(300)	2.9 (4.3)	3.3 (4.9)	N/A
15(375)	4.0 (5.9)	4.6 (6.8)	N/A
18 (450)	6.0 (8.9)	6.4 (9.5)	N/A
24 (600)	11.2 (16.7)	11.0 (16.4)	N/A
30 (750)	N/A	15.4 (22.9)	20.7 (30.8)
36 (900)	N/A	19.8 (29.4)	24.2 (36.0)
42 (1050)	N/A	26.4 (39.3)	N/A
48 (1200)	N/A	31.3 (46.6)	41.8 (62.3)
54 (1350)	N/A	34.6 (51.5)	N/A
60 (1500)	N/A	45.2 (67.3)	55.0 (81.9)

* Weights are for reference purposes only. Actual values will vary. For product-specific weights, contact an ADS Representative

In order to evaluate for possible flotation problems many factors were considered and several assumptions had to be made based on typical installation conditions. A detailed list of the design assumptions and other design considerations are available in Technical Note 5.05: *Pipe Flotation*. A summary of the fill required to prevent flotation is shown in Table 5-9. Note that in many cases, less than one foot (0.3m) is needed to prevent flotation but for structural purposes, minimum cover requirements will be greater based on pipe diameter and loading conditions. Due to many factors affecting flotation, several assumptions had to be made. For a detail list of the assumptions made, please refer to Technical Note 5.05: *Pipe Flotation*.

In spite of their light weight, ADS products will not float when adequate cover is placed on the pipe. Additionally, if effluent were in the pipe, as would be likely in the case of a fully saturated soil, its weight would further hinder flotation.

A second very important variable is the burial depth. During installation when the pipe has not yet been covered over with soil, flotation potential increases. If conditions on a specific project differ greatly from these and flotation is believed to be a valid consideration, ADS Application Engineers are available to help determine the extent of the problem.

Table 5-9
Minimum Cover Required to Prevent Flotation

Diameter in. (mm)	Cover in. (mm)	
	Single Wall	Dual or Triple Wall
4 (100)	3 (77)	3 (77)
6 (150)	4 (102)	4 (102)
8 (200)	6 (152)	5 (127)
10 (250)	7 (178)	7 (178)
12 (300)	9 (229)	9 (229)
15 (375)	11 (280)	11 (280)
18 (450)	13 (330)	13 (330)
24 (600)	17 (432)	17 (432)
30 (750)	N/A	22 (559)
36 (900)	N/A	25 (635)
42 (1050)	N/A	29 (737)
48 (1200)	N/A	33 (838)
60 (1500)	N/A	40 (1016)

PARALLEL PIPE INSTALLATIONS

Sewer pipes can be installed parallel when the capacity supplied by one of the pipes is not sufficient, such as in a relief situation.

A minimum amount of backfill is needed to provide adequate side support and a minimum spacing is also needed to compact the fill properly to develop this support. Generally, accepted minimum spacings are shown in Figure 5-6. These recommendations assume there are no fittings connecting the two adjacent runs; if fittings are used, spacing recommendations will differ and are outlined in Section 6: *Retention/Detention*.

Figure 5-6
Minimum Pipe Spacing

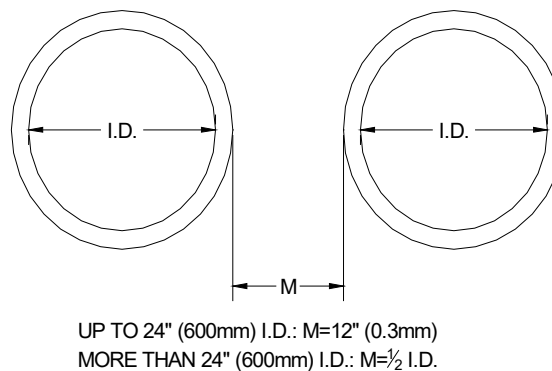

STEEP SLOPE INSTALLATIONS

In applications where a steep slope is necessary, generally slopes equal to or greater than 12%, precaution must be taken to ensure the application conditions will not adversely affect the pipe structure or flow characteristics. One design consideration should be proper venting. The pipe must be properly vented to ensure negative pressure does not form inside the pipe. Venting can be provided along the pipe slope, at the head of the slope, or by designing the flow in the slope to not flow more than 75% full in peak design flow conditions. Next, thrust blocks must be used at all fittings and grade changes. Change in flow direction can cause excessive force against the pipe wall; therefore thrust blocks must be used to dissipate this energy. Thrust blocks should be constructed as designed and specified by the project engineer for the specific project conditions. Finally, consideration must be given to pipe slippage along the slope. Pipe slippage can result in slope failure of the surrounding soil, structural damage of the pipe wall, or compromising of joint quality for the overall system. Pipe should be restrained through the use of concrete blocks or pipe anchors.

Note: Twelve percent grade is listed for reference purposes only, additional design consideration may be necessary for slopes less than 12% where slope stabilization, negative pressure, or water hammer, may be of concern.

CAMBERED INSTALLATIONS

Some pipe installations may need to design for uneven settlement regardless of the backfill envelope quality and construction. High embankments are especially prone to uneven settlement because the load on the pipe near the center of the embankment will be greater than at the top of the slope. In order to eliminate low pockets under the embankment, the pipe should be cambered.

Cambering is the process of installing the pipe so that the expected settlement will create the design slope. It can be achieved by installing the upstream half of the pipe on a flat grade and downstream half on a grade that is larger than design, as shown in Figure 5-7. Corrugated pipe, because of its flexibility, can be cambered quite easily. A qualified soils engineer should be consulted for this specialized situation.

Figure 5-7
Cambered Pipe Installations

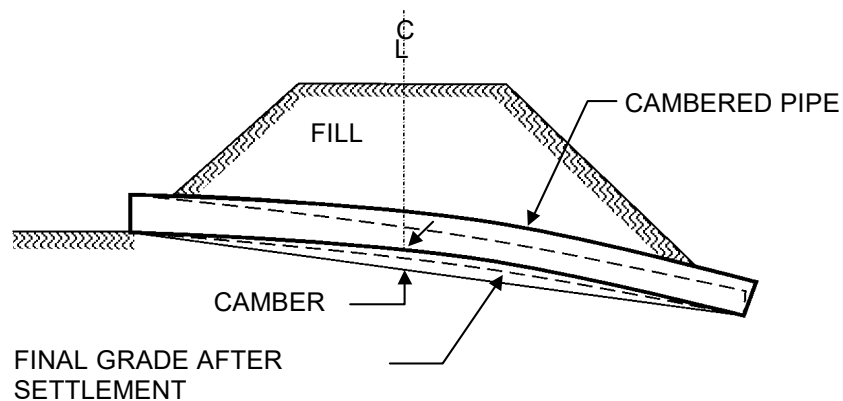

SLIPLINING

Due to abrasive or corrosive environments, premature deterioration of some types of pipe may occur. In lieu of a total replacement, sliplining the existing pipe with ADS thermoplastic pipe is often an economical and efficient way to significantly extend a culverts' service life. Typically, ADS thermoplastic pipe can only be used for open-ended applications where the pipe does not need to be bent for installation. Other considerations during design and pre-construction should include the inside and outside diameter of the carrier pipe and new slipline pipe, length of installation and grout installation. For more information, refer to Technical Notes 5.06, and 5.14, *Sliplining Considerations* for more details.

POST-CONSTRUCTION INSPECTION

Generally, no post construction is necessary for ADS pipe installations; however it is good practice to perform a visual inspection to insure proper line and grade have been achieved. It is important to understand that under normal conditions, any deflection will be realized within the first thirty (30) days after installation. This affords the inspector the opportunity to inspect the pipe shortly after installation with the ability to note deficiencies before the project is complete. The inspection should be performed after the pipe has been laid and backfilled, but may be before final paving has been placed.

The following outlines various inspection methods commonly specified for flexible pipes (plastic or metal). Additional post-installation inspection and testing information is available in Technical Note 5.07: *Post Installation Testing for HDPE Pipe*, Technical Note 5.08: *Laser Profiling of Flexible Pipe*, 5.17: *Post Installation Testing SaniTite HP Pipe* and 5.20: *Post Installation Testing of HP Storm*

Visual Inspection

A visual inspection will usually reveal improper line and grade as well as excessive deflection. For most projects, which specify a soil-tight or silt-tight joint performance, a visual inspection is sufficient to insure a successful installation. Caution is advised when inspecting pipe or entering manhole or inlet structures to insure compliance with all OSHA regulations.

Infiltration/Exfiltration Testing

For systems designed for watertight applications without specifying any ASTM specification for testing, an infiltration/exfiltration test is a simple and easy method of insuring proper joint performance. For an exfiltration test, a run of piping is tested by filling the system with water from structure to structure (manhole or inlets), with appropriate bulk heads or pipe bladders to seal off the pipe from the structure. Allow the system to stabilize for 24 hours, measuring the water level at the beginning of the test and then measuring the water level again after a specified period of time. The drop in water level can then be converted to gallons leakage/ inch pipe diameter/ mile length of pipe /day and compared to the permissible level established for the project. In the absence of a specified level, 200-gal/ in. dia. of pipe/ mi of sewer/ day is commonly considered watertight for storm and sanitary sewer applications. An acceptable ASTM specification for testing infiltration/exfiltration is ASTM F2487.

Air Testing

After the pipe has been laid and backfilled, each section of the pipeline between manholes may be tested using standard procedures for a low pressure air test. Individual joints may also be tested with appropriate equipment. This test is usually for systems where performance standards require watertight joints. ASTM F1417 may be used for air testing these systems and shall be completed from structure to structure or for individual joints. Fabricated structures and fittings shall not be tested to avoid damaging these components.

ASTM F1417 specifies a 3.5 psi air pressure be held for a specified length of time based on the pipe diameter with a maximum 0.5 psi pressure drop. Although the diameters listed in ASTM F1417 only include up to 36-inch (900mm), linear interpolation for larger diameters is generally acceptable. Pipe diameters greater than 36-Inch shall be tested in accordance to ASTM F3058 *Preliminary field Testing of Thermoplastic Pipe Joints for Gravity Flow (Non-Pressure) Sewer Lines*.

5-8 APPENDIX A-5

Table A-5-1A
Available U.S. Product-Specific Technical Literature & Detail Drawings

	Storm Sewer			Sanitary Sewer		Irrigation
Product	N-12 Pipe per ASTM F2306 /AASHTO	N-12 Pipe & Mega Green per ASTM F2648	HP STORM	Sanitite®	Sanitite® HP	N-12 Low Head Pipe
Minimum & Maximum Cover	Technical Note 2.01	Technical Note 2.02	Technical Note 2.04	Technical Note 2.01	Technical Note 2.05	Technical Note 2.01
Trench Installation Details	STD-101	STD-101A	STD-101D, 101E	STD-101	STD-101F	STD-101
Connections to Manholes & Structures	200 Series	200 Series	200 Series	200 Series	200 Series	200 Series

Table A-5-1B
Available Canadian Product Specific Technical Literature & Detail Drawings

	Storm Sewer		Sanitary Sewer
Product	N-12 Pipe per CSA B182.8	Sanitite® HP	Sanitite® HP
Minimum & Maximum Cover	Technical Note 2.01C	Technical Note 2.05C	Technical Note 2.05C
Trench Installation Details	STD-101	STD-101F	STD-101F
Connections to Manholes & Structures	200 series	200 series	200 series

Table A-5-2A
Minimum Installation Requirements for ADS Thermoplastic Products (U.S.)

		AASHTO or ASTM F2306	ASTM F2648 or Mega Green	HP STORM for Storm Drainage	SaniTite & SaniTite HP for Sanitary Sewer	N-12 Low Head
Minimum Cover (<2-ft) Backfill Recommendations	Bedding	Class 1, 2 or 3 loosely placed in middle 1/3, 90% SPD in remainder	Class 1 or 2 loosely placed in middle 1/3, 90% SPD in remainder	Class 1, 2 or 3 loosely placed in middle 1/3, 90% SPD in remainder	Class 1 or 2 loosely placed in middle 1/3, 90% SPD in remainder	Class 1 or 2 loosely placed in middle 1/3, 90% SPD in remainder
	Haunch & Initial Backfill	Class 1 Class 2 @ 90% Class 3 @ 90% SPD	Class 1 Class 2 @ 90% SPD	Class 1 Class 2 @ 90% Class 3 @ 90% SPD	Class 1 Class 2 @ 90% SPD	Class 1 Class 2 @ 90% SPD
Maximum Cover Backfill Recommendations	Bedding	Class 1, 2 or 3 loosely placed in middle 1/3, 90% SPD in remainder	Class 1, 2 or 3 loosely placed in middle 1/3, Class 1, 2 @ 90% or Class 3 @ 95% SPD in remainder	Class 1, 2, 3 or 4 loosely placed in middle 1/3, Class 1, Class 2 or Class 3 @ 90% or Class 4 @ 95% SPD in remainder	Class 1 or 2 loosely placed in middle 1/3, 90% SPD in remainder	Class 1, 2 or 3 loosely placed in middle 1/3, 90% SPD in remainder
	Haunch & Initial Backfill	Class 1 Class 2 @ 85% Class 3 @ 90% SPD	Class 1 Class 2 @ 90% Class 3 @ 95% SPD	Class 1 Class 2 @ 85% Class 3 @ 90% Class 4 @ 95% SPD	Class 1 compact Class 2 @ 90% SPD	Class 1 Class 2 @ 85% Class 3 @ 90% SPD

1) Table provides minimum compaction levels for the respective soil class; higher compaction levels than stated are acceptable and may be necessary depending on fill height.

2) For additional information, refer to the product specific Technical Note on minimum & maximum cover recommendations.

Table A-5-2B Minimum Installation Requirements for ADS Thermoplastic Products (Canadian)

		CSA B182.8	BNQ 1809
Minimum Cover (<=2-ft) Backfill Recommendations	Bedding	Class 1, 2 or 3 90% SPD	MG-20 or CG-14 @ 90% SPD
	Haunch & Initial Backfill	Class 1 Class 2 @ 90% Class 3 @ 95%	MG-20 or CG-14 @ 90% SPD
Maximum Cover Backfill Recommendations	Bedding	Class 1, 2 or 3 90% SPD	MG-20 or CG-14 @ 90% SPD
	Haunch & Initial Backfill	Class 1 Class 2 @ 90% Class 3 @ 90%	MG-20 or CG-14 @ 90% SPD

- 1) Table provides minimum compaction levels for the respective soil class; higher compaction levels than stated are acceptable and may be necessary depending on fill height.
- 2) For additional information, refer to the product specific Technical Note on minimum & maximum cover recommendations.

OTHER TECHNICAL RESOURCES

(APPLICABLE TO ALL ADS PRODUCTS)

ADS Technical Notes

Technical Note 5.01: *Recommended Use of Trench Boxes*

Technical Note 5.02: *Flowable Fill Backfill for Thermoplastic Pipe*

Technical Note 5.03: *HDPE Pipe Repair Options*

Technical Note 5.04: *HDPE and HP Connections to Manholes and Structures*

Technical Note 5.05: *Pipe Flotation*

Technical Note 5.06: *Culvert Sliplining with HDPE Pipe*

Technical Note 5.07: *Post-Installation Testing for HDPE*

Technical Note 5.08: *Laser Profiling of Flexible Pipe*

Technical Note 5.09: *Utility Crossings*

Technical Note 5.10: *Integral Bell Transition for HDPE*

Technical Note 5.11: *Sliplining Extended Lengths with HDPE Pipe*

Technical Note 5.12: *HP Storm Drainage Pipe Repair Options*

Technical Note 5.13: *SaniTite HP Sanitary Sewer Pipe Repair Options*

Technical Note 5.14: *Culvert Sliplining with HP Pipe*

Technical Note 5.15: *Integral Bell Transitions for HP Storm Pipe*

Technical Note 5.16: *Methods for Sealing Vent Tubes*

Technical Note 5.17: *Post Installation Testing of SaniTite HP*

Technical Note 5.18: *Lining of Casings with SaniTite HP Pipe*

Technical Note 5.20: *Post Installation Testing of HP Storm*

Retention/Detention



6-0 RETENTION/DETENTION SYSTEMS

TABLE OF CONTENTS

- 6-1 Stormwater Management Today..... 6-2**
- 6-2 Subsurface Retention/Detention Products 6-3**
 - Retention/Detention Systems 6-3
- 6-3 Choosing the Correct Retention/Detention System 6-5**
- 6-4 Designing a Retention/Detention System 6-6**
 - Check Regulations 6-6
 - Calculate Storage Capacity 6-6
 - Determine System Layout 6-8
 - Select Products 6-8
 - Evaluate Maintenance Requirements 6-10
 - Select Fittings and Accessories..... 6-11
- 6-5 Design Aids..... 6-15**
- 6-6 Best Management Practices (BMP)..... 6-16**
- 6-7 Technical Assistance 6-16**
- 6-8 Other Technical Resources..... 6-17**

Figures

- 6-1 Retention/Detention System Selection Guidelines 6-5
- 6-2 Typical Retention/Detention Cross Section 6-7
- 6-3 Triple Component Retention/Detention Manifold with
Size on Size Connections..... 6-9
- 6-4 Retention/Detention Clean-Out Ports..... 6-11
- 6-5 Typical Catch Basin (Non-Traffic Areas Only) 6-12
- 6-6 Water Quality Unit 6-13
- 6-7 Typical End Cap Section 6-13
- 6-8a Roof Drain with Wye Cleanout 6-14
- 6-8b Roof Drain with Tee Cleanout 6-14
- 6-9 ADS Retention/Detention System Design Tool 6-15

Tables

- 6-1 ADS Retention/Detention Systems Features and Benefits 6-4
- 6-2 Storage Capacities of N-12 Pipes 6-7
- 6-3 Perforation Patterns 6-10

6-1 STORMWATER MANAGEMENT TODAY

Stringent environmental regulations and increasing land values have made finding an effective way to manage stormwater runoff – one that both protects groundwater quality *and* complies with agency regulations – a high priority for land developers and engineers. Typically, the stormwater management method selected involves some type of stormwater retention or detention system, and possibly other products that improve the effectiveness of the management method.

The purpose of a *stormwater retention system* is to capture stormwater runoff in a designated area where it can be allowed to percolate into the ground. The net effect is fairly rapid exfiltration of stormwater into the adjacent native soil. A *stormwater detention system*, on the other hand, slows and temporarily holds stormwater runoff so that it can be released into the environment at a controlled rate. An effective means of stormwater management can be retention, detention, or a combination of both.

Stormwater retention/detention systems vary widely in design, from open ponds to subsurface piping systems and underground vaults to gravel pits. The most frequently used designs are open ponds and subsurface piping and/or vault systems. Open ponds occupy a great deal of space, reducing the land available for facilities, such as parking lots, playgrounds, and landscape areas. In addition, they create safety risks and serve as a breeding ground for insects.

Subsurface systems, however, offer several advantages in addition to effective stormwater runoff management. Because they are below grade, subsurface systems increase the amount of usable land since some facilities, like recreational green areas or parking lots, can be built over them. Subsurface systems also decrease safety risks because they are inaccessible to the public, are more easily maintained, and are options in situations where high groundwater tables or small lot sizes make a pond impractical.

Subsurface retention/detention systems can be designed in almost any shape and size using a variety of materials. Plastics, especially high density polyethylene (HPDE) and polypropylene (PP) are an attractive, economical option for retention/detention stormwater management. They are often faster and more cost-effective to install than other systems, and are highly resistant to the damaging effects of salts, oils, fuels, and other chemicals, and freeze/thaw conditions. In aggressive conditions plastics can provide a long service life.

6-2 ADS[®] SUBSURFACE RETENTION/DETENTION PRODUCTS

A long-time leader in both water management and plastics technology, ADS offers different options for subsurface retention/detention systems to meet the management needs of practically any stormwater runoff situation. Retention/Detention systems are offered with a choice of N-12[®], N-12[®] ST IB, either solid or with perforations, or N-12[®] WT IB pipe.

RETENTION/DETENTION SYSTEMS

ADS corrugated polyethylene pipes are the building blocks of the retention/detention product line. N-12 pipes (see Specifications section) use a state-of-the-art design that incorporates a smooth inner wall and a corrugated outer wall. The smooth inner wall combines superior hydraulics and the ability to resist abrasion and corrosion. The corrugated outer wall provides the strength necessary to withstand heavy traffic loads with varying cover heights. See Figure 6-2 in this section for minimum recommended cover heights for standard installations.

N-12 ST pipe features a bell-and-spigot joint that promotes faster, easier installation. This joining method ensures joint alignment, improves joint reliability, and eliminates the need for glue, split couplers, or wire ties. N-12 ST joints meet or exceed a soil-tight level of performance. N-12 pipe requires coupling bands for soil-tight performance. The pipe itself is available with or without perforations.

N-12 WT pipe features joints which provide a watertight level of performance meeting the laboratory requirements set in ASTM D3212. In field applications, N-12 WT pipe is subject to allowable leakage rates and may be considered watertight per gasketed storm drain and even some sanitary sewer standards. ADS N-12 WT detention systems, which include N-12 WT pipe and compatible fabricated fittings, are intended for non-pressure, gravity flow storm water detention and will be subject to greater leakage rates and may not be appropriate for applications requiring long-term fluid containment. For these types of applications please refer to ADS Technical Note 7.01 *Rain Harvesting with HDPE Pipe* or contact ADS for additional details or assistance with your specific application.

The ADS retention/detention system utilizes corrugated polyethylene pipe and specially designed manifolds and other fittings to provide a complete retention/detention system. ADS can assist the customer in laying out the actual system with all necessary components for each application. From the contractor's point of view, retention/detention components coupled with ADS technical assistance allows the products to fit together much like building blocks.

Table 1 summarizes the primary features and benefits of retention/detention systems, and how the ADS system meets the needs of the application.

Table 6-1
Retention/Detention Systems Features and Benefits

Subsurface retention/detention design	<ul style="list-style-type: none"> • Increases the usable land available • Reduces hazards and safety risks • Reduces system maintenance costs • Recharges groundwater table more efficiently
Unique Manifold Designs	<ul style="list-style-type: none"> • Increased structural integrity • Increased versatility of manifold design options • Easier assembly and installation • Helps to reduce debris in laterals and allows for easy cleaning
Quality Plastic Composition	<ul style="list-style-type: none"> • Resists harmful effects of salts, oils, fuels, chemicals • Withstands repeated freeze/thaw cycles • Strong, yet light in weight – easier, safer, more cost-effective to install • Highly abrasion resistant for longer service life than metal or RCP • Unaffected by extremes in pH; won't rust or deteriorate
System options: <i>Retention/Detention with N-12, N-12 ST or N-12 WT pipe</i>	<ul style="list-style-type: none"> • High strength – withstands H-25 and HS-25 traffic loads under minimum cover • Meets specific application requirements: 4- to 60-inch (100 to 1500mm) diameters, lengths to 20 feet (6m), perforated or non-perforated, soil-tight or watertight joints, variety of manifold pipe designs
Variety of Fittings	<ul style="list-style-type: none"> • Promotes faster, more versatile system installations • Enables systems to meet specific application requirements • Reduces labor for system installation and/or modification
Custom product fabrication	<ul style="list-style-type: none"> • Meets unique/specialized application needs • Reduces labor for system installation and/or modification

6-3 CHOOSING THE CORRECT RETENTION/DETENTION SYSTEM

All retention/detention products are specifically designed for subsurface stormwater management systems. Figure 6-1 assists the specifier in selecting the correct product to use for a particular subsurface stormwater application.

Figure 6-1
Retention/Detention System Selection Guidelines

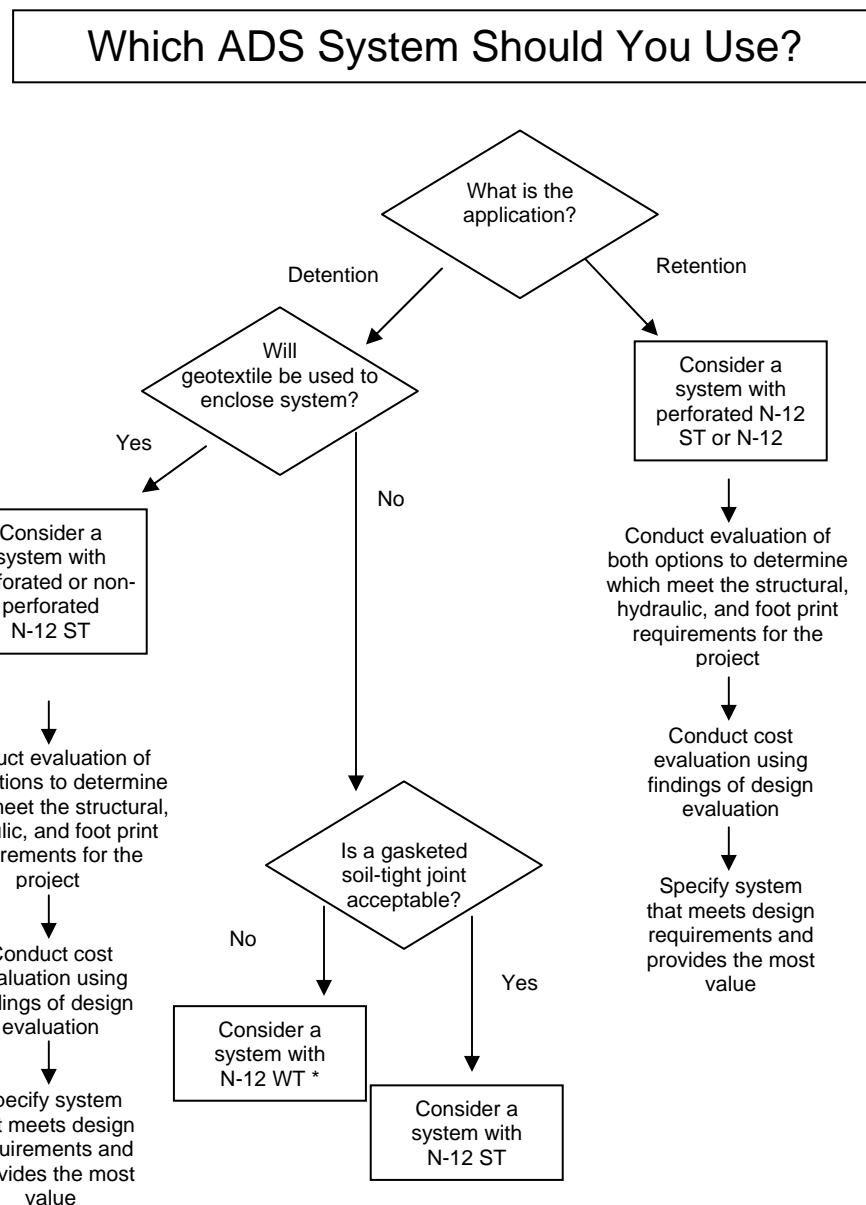

* ADS retention/detention systems are intended for storm sewer applications. For use of ADS products in applications requiring little to no leakage, please see ADS Technical Note 7.01: *Rain Harvesting with HDPE Pipe*.

6-4 DESIGNING A RETENTION/DETENTION SYSTEM

The following general guidelines provide a systematic approach to designing a retention/detention subsurface stormwater management system.

CHECK REGULATIONS

1 – Check with federal, state, and local agencies for regulations on subsurface stormwater retention/detention systems.

Key issues to resolve include: Should the system be a retention system, detention system, or a combination of both? Are water quality structures required? If so, which structures are approved? Is a soil-tight or watertight joint required?

CALCULATE STORAGE VOLUME REQUIRED

2 – Calculate the storage volume required for the specific site based on site conditions and local stormwater regulations.

The storage volume required for a given site is often regulated as the excess of stormwater runoff resulting from post-construction conditions. In essence, all new runoff and peak flows generated from a project site must be accounted for through adequate sizing of the stormwater system and/or onsite storage and dissipation of excess water. There are numerous ways and methods determining required storage volume and peak flows such as: Rational method, Unit Hydrographs, TR55 etc. The designer should choose a specific method based on their experience and those requirements as established by the local regulatory agency.

CALCULATE STORAGE CAPACITY

3 – Calculate the size, in feet or meters, of the system that will provide stormwater capacity requirements.

Retention/detention systems can achieve needed storage capacity by using either larger diameter corrugated polyethylene pipe and a shorter overall system length, or by using smaller diameter pipe and a longer system length. The final decision depends on the size of the site, its groundwater level, and cover requirements. Figure 6-2 shows a typical cross-section of a retention/detention system. Table 6-2 summarizes retention and detention volumes, pipe lengths, and surface area requirements based on this section; other system designs will result in different values.

Figure 6-2
Typical Retention/Detention Cross Section

Note: This is a typical cross section only. See Structures, Section 2, or Installation, Section 5, of the *Drainage Handbook* for specific installation guidelines.

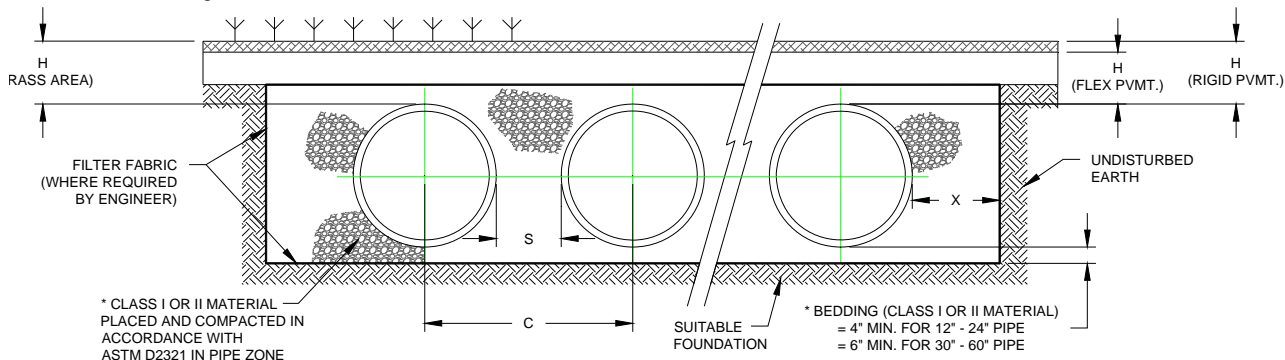

MINIMUM H (FLEX PVMT), H (RIGID PVMT) = 12" FOR UP TO AND INCLUDING 36" HDPE PIPE
= 24" FOR 42" THROUGH 60" HDPE PIPE

* CLASS I BACKFILL REQUIRED AROUND 60" DIAMETER FITTINGS.

MAXIMUM FILL HEIGHT LIMITED TO 8-FT OVER FITTINGS FOR STANDARD INSTALLATIONS. CONTACT REPRESENTATIVE WHEN MAXIMUM FILL HEIGHTS EXCEED 8-FT FOR INSTALLATION CONSIDERATIONS.

Table 6-2
Storage Capacities of N-12[®], N-12[®] ST, and N-12[®] WT Pipes

Nominal Inside Diameter	Average Outside Diameter	"X" Spacing	"S" Spacing ¹	"C" Spacing ¹	Pipe Volume ²	Stone Void Volume ^{3,4,5}	Total Retention Storage	Retention Surface Area Required	Detention Surface Area Required
in. (mm)	in. (mm)	in. (mm)	in. (mm)	in. (mm)	ft ³ /ft (m ³ /m)	ft ³ /ft (m ³ /m)	ft ³ /ft (m ³ /m)	ft ² /ft ³ (m ² /m ³)	ft ² /ft ³ (m ² /m ³)
12 (300)	14.5 (368)	8 (210)	10.9 (280)	25.4 (650)	0.81 (0.07)	0.84 (0.08)	1.65 (0.15)	1.3 (4.2)	2.7 (8.6)
15 (375)	18 (457)	8 (210)	10.9 (280)	28.9 (750)	1.2 (0.11)	1.1 (0.10)	2.3 (0.21)	1.1 (3.5)	1.97 (6.4)
18 (450)	21 (533)	9 (230)	14.3 (360)	35.3 (900)	1.8 (0.16)	1.4 (0.13)	3.2 (0.29)	0.93 (3.0)	1.6 (5.4)
24 (600)	28 (711)	10 (260)	13.4 (340)	41.4 (1050)	3.1 (0.29)	2.0 (0.18)	5.1 (0.47)	0.68 (2.2)	1.1 (3.6)
30 (750)	36 (914)	18 (460)	17.1 (430)	53.1 (1350)	4.9 (0.46)	3.1 (0.28)	8.0 (0.74)	0.55 (1.8)	0.90 (3.0)
36 (900)	42 (1067)	18 (460)	21 (530)	63.0 (1600)	7.1 (0.66)	4.2 (0.39)	11.3 (1.05)	0.47 (1.5)	0.74 (2.4)
42 (1050)	48 (1219)	18 (460)	24 (610)	72 (1830)	9.2 (0.87)	5.8 (0.53)	15.0 (1.40)	0.40 (1.3)	0.65 (2.1)
48 (1200)	54 (1372)	18 (460)	24.5 (620)	78.5 (2000)	12.4 (1.15)	6.7 (0.62)	19.1 (1.77)	0.34 (1.1)	0.53 (1.7)
60 (1500)	67 (1702)	18 (460)	23 (580)	90 (2290)	19.3 (1.79)	8.5 (0.78)	27.8 (2.57)	0.27 (0.89)	0.39 (1.3)

Notes:

See Figure 6-2 for typical cross section used in volume calculations. Bedding depth assumed 4" for 12"-24" pipe and 6" for 30"-60" pipe.

1. Based on A-profile pipe.
2. Actual ID values used in calculation.
3. Stone Porosity assumed 40%.
4. Stone height above crown of pipe is not included in void volume calculations.
5. Calculation is based on the average OD of the pipe.

See "Design Aids" for a system design tool to calculate total HDPE pipe system storage with an example calculation.

DETERMINE SYSTEM LAYOUT

4 – Determine the most cost-effective system layout.

Fitting configuration can have a significant impact on overall system cost. A system with longer lateral runs and fewer manifold fittings is generally more cost effective than a wide system with short lateral runs. Additionally, placing a distribution manifold at one end of the system and simply placing end caps at the opposite end of each lateral can prove to be more cost effective than distribution manifolds at either end of the system.

SELECT PRODUCTS

5 – Select the Retention/Detention components specifically suited for the system design (refer to Figure 6-1).

Manifold design alternatives are:

- Standard manifold with attached reducing connections to the laterals or standard manifold with size-on-size connections to the laterals. Manifold systems typically incorporate any combination of single component manifolds (i.e. one lateral), double component manifolds (i.e. two laterals), and triple component manifolds. Figure 6-3 shows a triple component manifold layout for size-on-size manifold systems; specific information regarding the sizes and manifold lengths are included in the Fittings section of this handbook or in the *ADS Fittings Manual*.
- Series of standard fittings including tees and elbows. The size of this layout will be affected by the fitting dimensions. The and Fittings section of this handbook and the *ADS Fittings Manual* contains more information.
- Custom manifolds with attached concentric or eccentric reducing connections to laterals. Custom manifolds are available for special site conditions. Custom fittings may require special installation considerations; contact your local ADS sales representative when using a custom fitting. It should be noted that minimum lateral spacing must be maintained for all manifold design alternatives. For custom manifolds, see the Technical Assistance section of this chapter.
- Maximum fill heights over manifold fittings are generally limited to less than 8-ft (2.4-m). Contact your local ADS sales representative for installation considerations for manifold fittings in excess of 8-ft.

Figure 6-3
Watertight Triple Component Retention/Detention Manifold with Size on Size Connections

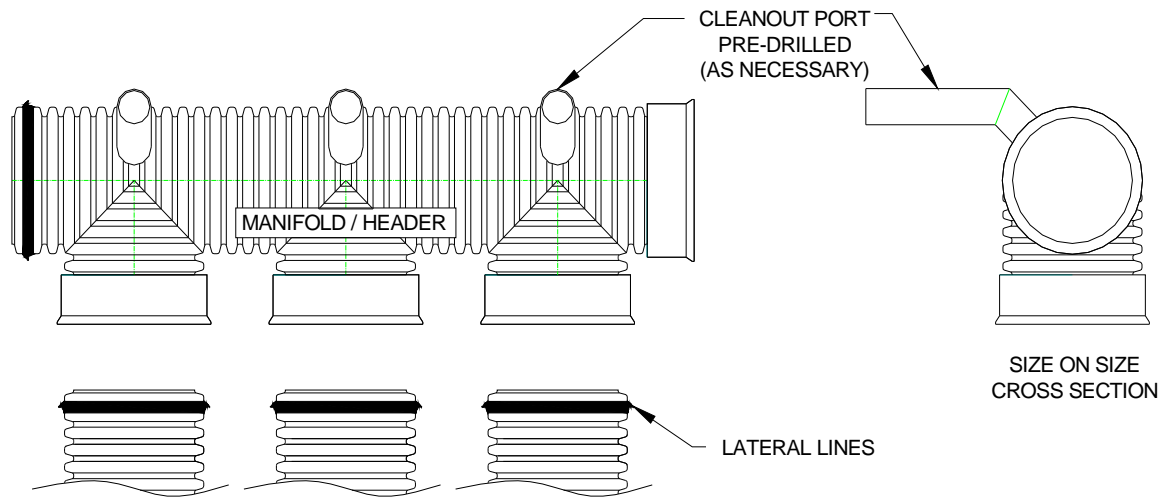

NOTE: For Retention/Detention System size-on-size manifold dimensions refer to the Fittings section

In retention systems, perforation pattern options are:

- ASTM F2306 perforations. This is considered the ADS standard perforation pattern and is stocked at most manufacturing facilities. Table 3 provides more detail.
- Other perforation patterns may be available; please refer to Technical Note 1.01: *Dual Wall HDPE Perforation Patterns* for or consult with an ADS sales representative.

Table 6-3
Perforation Patterns

Nominal I.D.		Perforation Type	Maximum Diameter		Minimum Inlet Area	
in	mm		in	mm	in ² /ft	cm ² /m
12	300	Circular	0.375	10	1.5	30
15	375	Circular	0.375	10	1.5	30
18	450	Circular	0.375	10	1.5	30
24	600	Circular	0.375	10	2.0	40
30	750	Circular	0.375	10	2.0	40
36	900	Circular	0.375	10	2.0	40
42	1050	Circular	0.375	10	2.0	40
48	1200	Circular	0.375	10	2.0	40
54	1350	Circular	0.375	10	2.0	40
60	1500	Circular	0.375	10	2.0	40

EVALUATE MAINTENANCE REQUIREMENTS

6 – Evaluate system maintenance requirements.

Should stormwater debris be encouraged to settle in the system’s manifold pipe or be allowed to flow into the laterals? Does the system need such items as clean-out ports, catch basins with sump areas, settling basins, and water quality units? If so, how many are needed and where should they be located? Refer to Figures 6-5 through 6-9 as examples of products used for maintenance purposes.

- Concentric reducing manifold components (components where the reducing stub is positioned in the center of the main fitting ie: flow lines do not match) can promote trapping of debris and sediment in designated sections of the system.
- Clean-out stubs and jetting ports should be strategically placed to allow ease of maintenance (commonly located to push debris and sediment toward the downstream end of the system with clean-out positioned near or at the downstream outlet)
- Vent ports should be strategically positioned to prevent any airlocks in the manifold or lateral stubs.
- Water Quality Units may be used at the inlet end of the system to reduce debris or sediment entering the system. Units may also be used at the outlet end of the system as a final clarifying stage for the stormwater prior to discharge into the natural waterway or sewer system.

For additional information regarding inspection and maintenance of retention/detention systems, refer to Technical Note 6.01: *Retention/Detention System Maintenance*.

SELECT FITTINGS AND ACCESSORIES

7 – Select the related ADS fittings needed to assemble and connect the Retention/Detention system.

These include such products as tees, elbows, stubs, adapters, reducers, flared end sections, end caps, and prefabricated end plates. For a listing of commonly specified system accessories, refer to Technical Note 7.01: *Retention/Detention System Maintenance*. All available standard fittings and accessories are provided in the *ADS Fittings Manual*.

Figure 6-4
Retention/Detention Cleanout and Riser Ports

For additional detail see ADS Standard Detail #703

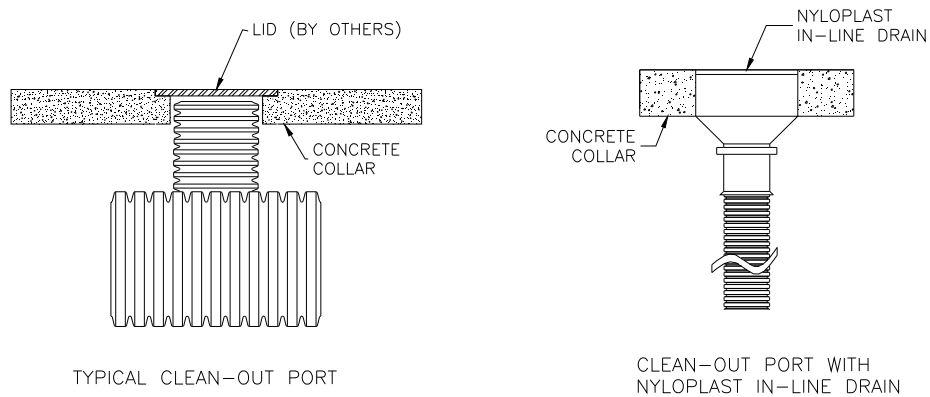
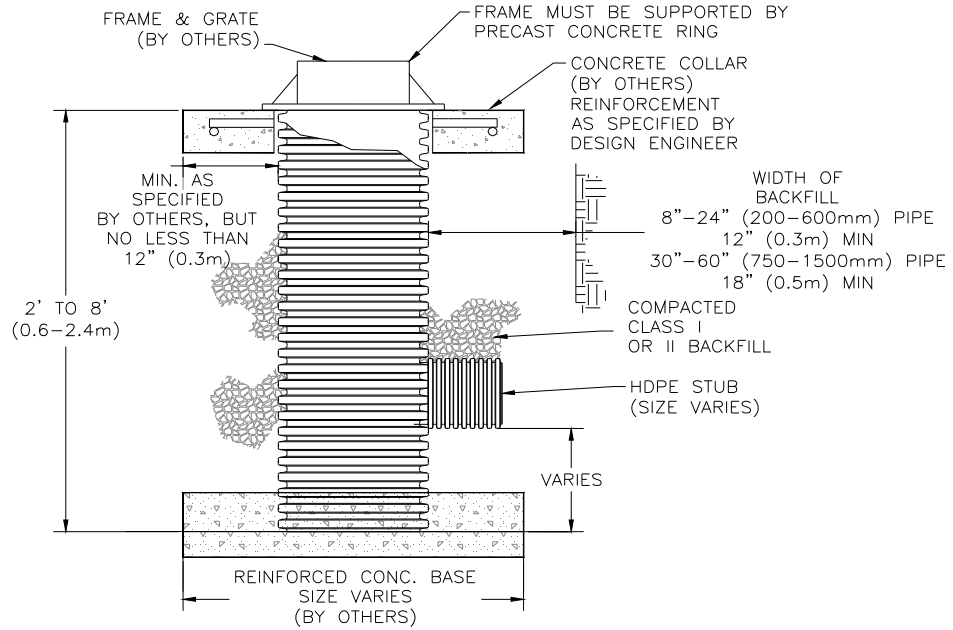

Figure 6-5
Typical Catch Basin (Non-Traffic Areas Only)

For additional detail see ADS Standard Detail #401



NOTE: For more information on this application, refer to the Vertical Installations topic in the Installation section (Section 5) of the Drainage Handbook.

Figure 6-6
Water Quality Unit

For additional detail see ADS Standard Details #501 & #502

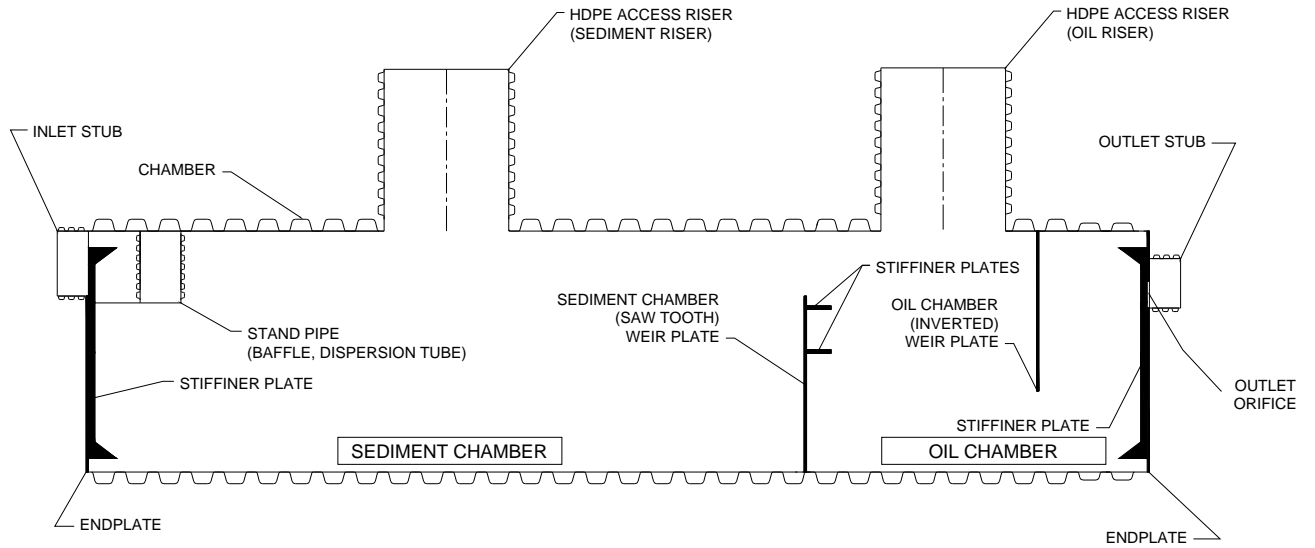

Figure 6-7
Typical End Cap Sections

For additional details see *ADS Fittings Manual*

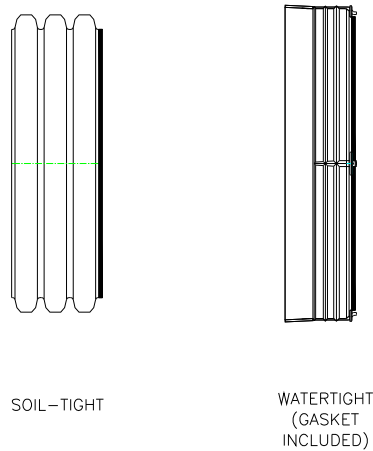

Figure 6-8a
Roof Drain with Wye Cleanout

For additional detail see ADS Standard Details #1001 & #1003

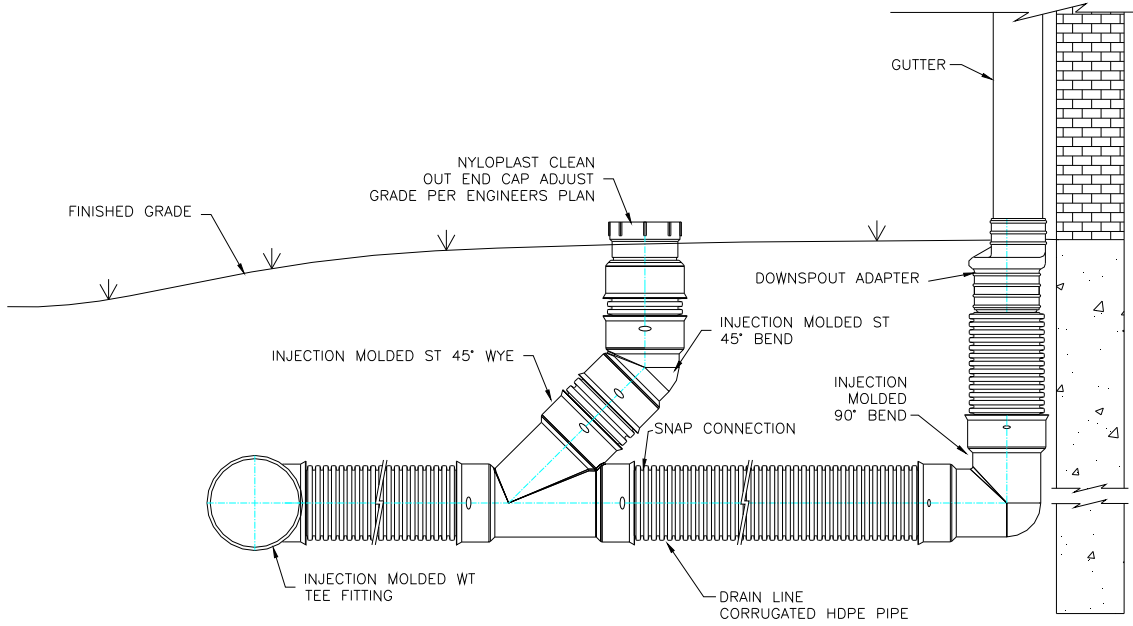
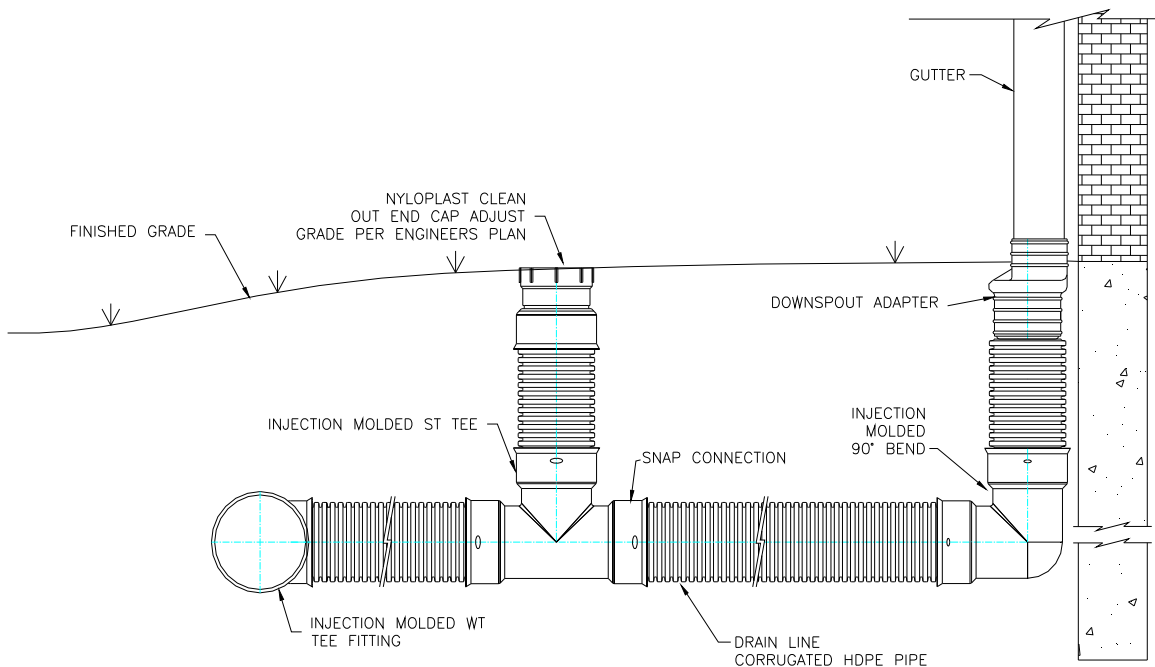

Figure 6-8b
Roof Drain with Tee Cleanout

For additional detail see ADS Standard Details #1002 & #1004



6-5 DESIGN AIDS

To aid in the design and layout of an HDPE pipe retention or detention system, a Retention/Detention sizing tool is available at www.ads-pipe.com or by contacting an ADS representative.

Figure 6-9 is a screen shot of the Retention/Detention sizing worksheet with example user inputs and the resulting information on the designed system. Some information provided for the designed system include: system storage (including stone storage, if applicable), system and excavation footprints, and estimated excavation. Also, a generic layout of the systems can be generated along with installation details for the system, risers, and cleanouts.

Figure 6-9
ADS Retention/Detention System Sizing Tool

Allows for user inputs with calculated results.



THE MOST ADVANCED NAME IN DRAINAGE SYSTEMS
Version 7.5

**STORMWATER RETENTION / DETENTION
PIPE SYSTEM SIZING WORKSHEET**

Enter or Select values in the Yellow fields ONLY

UNITS	
Unit of Measure	<input checked="" type="checkbox"/> Imperial (ft, in) <input type="checkbox"/> Metric (mm, m)

SYSTEM	
Joint Type	Plain End ST
Design Storage Volume	5240 CF
Average Cover Height ⁴	1.00 FT

Project Name: SAMPLE PROJECT

Location (City, State): U.S.A.

Prepared For: _____

Date Prepared: _____

Engineer: _____

Contractor: _____

Regional Engineer: _____

Area Sales Representative: _____

Surface Application: PARKING LOT

HEADER	LATERALS	BACKFILL																								
Header Diameter: <u>36</u> Number of Headers: <u>2</u> Perforate Headers?: <u>No</u> Include Header(s) in Storage Volume?: <u>Yes</u>	<table border="1" style="width: 100%; border-collapse: collapse;"> <thead> <tr> <th></th> <th>Lateral Diameter (in)</th> <th>Lateral Length (ft)</th> <th>Number of Laterals</th> <th># of Sticks / Lateral</th> <th>Approx. Length of End Stick</th> </tr> </thead> <tbody> <tr> <td>Group 1</td> <td><u>36</u></td> <td><u>96</u></td> <td><u>7</u></td> <td><u>5</u></td> <td><u>18.2-ft</u></td> </tr> <tr> <td>Group 2</td> <td><u>12</u></td> <td></td> <td></td> <td><u>0</u></td> <td><u>0-ft</u></td> </tr> <tr> <td>Group 3</td> <td><u>12</u></td> <td></td> <td></td> <td><u>0</u></td> <td><u>0-ft</u></td> </tr> </tbody> </table> <p>Perforate Laterals? <u>No</u></p>		Lateral Diameter (in)	Lateral Length (ft)	Number of Laterals	# of Sticks / Lateral	Approx. Length of End Stick	Group 1	<u>36</u>	<u>96</u>	<u>7</u>	<u>5</u>	<u>18.2-ft</u>	Group 2	<u>12</u>			<u>0</u>	<u>0-ft</u>	Group 3	<u>12</u>			<u>0</u>	<u>0-ft</u>	<p><i>A non-perforated system has been selected</i></p>
	Lateral Diameter (in)	Lateral Length (ft)	Number of Laterals	# of Sticks / Lateral	Approx. Length of End Stick																					
Group 1	<u>36</u>	<u>96</u>	<u>7</u>	<u>5</u>	<u>18.2-ft</u>																					
Group 2	<u>12</u>			<u>0</u>	<u>0-ft</u>																					
Group 3	<u>12</u>			<u>0</u>	<u>0-ft</u>																					

	STORAGE VOLUME			APPROXIMATE SYSTEM SIZE		EXCAVATION							
	Product Volume (CF)	Stone (CF)	ASV (CF)	Total System (CF)	Width (FT)	Length (FT)	Pipe Diameter (IN)	Width (FT)	Length (FT)	Disturbed Surface Area (SYD)	Excavation ² (CYD)	Estimated Backfill ³ (CYD)	ASV (CYD)
Group 1	5,245	0	0	5,245	35	105	36	38	108	455	729	534	0
Group 2	0	0	0	0	0	0	12	0	0	0	0	0	0
Group 3	0	0	0	0	0	0	12	0	0	0	0	0	0
TOTALS	5,245	0	0	5,245						455	729	534	0

100.1% of the required storage

NOTES

- 1 - Full Stick: Assumed a standard lay length of 10'-8"
- 2 - Excavation: Based on manufacturer's recommended trench width and bedding depth. Estimated volumes assume a flat system based on the user-entered Average Cover Height.
- 3 - Backfill: Does not account for pipe corrugations - calculated for conservative quantities. Not for use with take-offs or ordering purposes.
- 4 - Cover Height: For traffic installations, 1-ft of minimum cover is required for diameters 12-36", 2-ft for 42-60". Maximum cover shall not exceed 8-ft without consulting Applications Engineering.
- 5 - Bill of Materials: Does not differentiate between ST and WT fittings or between A and H profile connections. Determined on a project-specific basis.
- 6 - Quantities: Assumes all Groups are same diameter. Run separate calculations to determine quantities and costs for different Group diameters.

This Excel spreadsheet is provided for rough estimating purposes only. This tool is intended to assist the design engineer in sizing stormwater management systems using ADS pipe and manifold components. As with any calculation aid, this tool should be used for estimating only; the engineer must verify the assumptions and methods to ensure they satisfy the project and local design criteria.

6-6 BEST MANAGEMENT PRACTICES (BMP)

At ADS, managing our water resources is something close to our heart. For over a century, we have been an industry leader in environmental stewardship and protecting the quality of our water resources.

ADS is continually developing new, innovative ways to help municipalities, developers and contractors implement storm water management systems and meet EPA requirements. We offer a full line of Best Management Practices (BMP) products to manage the quality and quantity of storm water and meet increasing government regulations. Among our latest developments is the ADS Water Quality Unit offering outstanding performance in a lightweight unit. For more information related to BMPs or other drainage needs visit our website at www.ads-pipe.com.

6-7 TECHNICAL ASSISTANCE

Throughout system design, ADS, Inc. can assist you on a variety of technical issues, including:

- Product performance information and suggested product usage.
- Manifold pipe configuration and design.
- Number and spacing of system laterals (based on provided design storage).
- Existing product modifications; custom product fabrication.
- Suggestions to maximize cost effectiveness.

Please contact an ADS representative for further information.

6-8 OTHER TECHNICAL RESOURCES

ADS Technical Notes

Technical Note 1.01: *Perforation Patterns for Dual Wall HDPE*

Technical Note 6.01: *Retention/Detention System Maintenance*

Technical Note 7.01: *Rainwater Harvesting with HDPE Pipe*

ADS Standard Details

Standard Detail 7.01: *Typical Retention/Detention System Layout*

Standard Detail 7.02: *Typical Retention/Detention Cross Section*

Standard Detail 7.03: *Typical Riser and Cleanout*

General Tech Notes



7-0 GENERAL TECHNICAL NOTES

TABLE OF CONTENTS

Section 1 – General Specifications

- 1.01 Dual Wall HDPE Perforation Patterns
- 1.02 Single Wall HDPE Perforation Patterns
- 1.03 Storm Water Quality Units
- 1.04 Testing of Storm Water Quality Units
- 1.05 Pipe Joints and Gaskets
- 1.07 Manhole Adapter Guide – SaniTite HP, HP Storm, N-12 HDPE Pipe
- 1.08 Water Quality Device Oil Storage Volumes

Section 2 – Structures

- 2.01 Minimum and Maximum Burial Depth for Corrugated HDPE Pipe (per AASHTO)
- 2.02 Minimum and Maximum Burial Depth for Corrugated HDPE Pipe (per ASTM F2648)
- 2.03 Minimum and Maximum Cover Heights for Single Wall Corrugated HDPE Pipe
- 2.04 Minimum and Maximum Cover Heights for HP Storm Pipe for Storm Drainage
- 2.04A Minimum and Maximum Covert Heights for Alternate HP Storm Pipe Trench

Section 3 – Hydraulics

- 3.02 AdvanEdge Hydraulic Performance

Section 4 – Structures

- 4.01 Chemical Resistance of Polyethylene and Elastomers
- 4.02 Chemical Resistance of Polypropylene and Elastomers
- 4.03 Abrasion Resistance of Polypropylene

Section 5 – Installation

- 5.01 Recommended Use for Trench Boxes
- 5.02 Flowable Fill Backfill for Thermoplastic Pipe
- 5.03 HDPE Pipe Repair Options
- 5.04 HDPE and HP Storm Connections to Manholes and Structures for Storm Sewer Applications
- 5.05 Pipe Flotation
- 5.06 Culvert Sliplining with HDPE Pipe
- 5.07 Post Installation Testing for HDPE Pipe
- 5.08 Laser Profiling of Flexible Pipe
- 5.09 Thermoplastic Pipe and Utility Crossings
- 5.10 Integral Bell Transition for HDPE Pipe
- 5.11 Sliplining Extended Lengths with HDPE Pipe
- 5.12 HP Storm Drainage Pipe Repair Options
- 5.14 Culvert Sliplining with HP Pipe
- 5.15 Integral Bell Transition for HP Pipe Products
- 5.16 Methods for Sealing Vent Tubes
- 5.20 Post Installation Testing of HP Storm

Section 6 – Retention/Detention

- 6.01 Retention/Detention System Maintenance

Section 7 – Miscellaneous

- 7.01 Rainwater Harvesting with HDPE Pipe Cisterns

Technical Note

TN 1.01 Dual Wall HDPE Perforation Patterns

Overview

Perforated pipe plays an integral role in many applications of HDPE pipe. Generally, perforated pipe is used to accelerate the removal of subsurface water in soils or to allow storm water to percolate into the soil. Currently, two classifications of perforations are specified in the AASHTO material specifications for HDPE pipe: Class I, and Class II. The Class II perforation pattern comes standard when perforated pipe is ordered. Class One perforated pipe has limited availability. Please check with a local representative to determine availability. Both classes are explained in more detail in the AASHTO materials specifications (M294 and M252). AASHTO M252 covers pipe diameters 3- through 10-inch (75 - 250 mm) while M294 covers 12-inch through 60-inch (300 - 1500 mm).

Standard Perforation Patterns

AASHTO Class II Perforation

The following terminology for perforations is derived from the applicable AASHTO specification. Differences between the specifications are covered in the table below. Class II perforations shall be located in the outside valleys of the corrugations, be circular and/or slotted and evenly spaced around the circumference and length of the pipe. The perforations shall be located in the outside valleys of the corrugations. The water inlet area shall be no less than 0.945 in²/ft (20 cm²/m) for pipe diameters 4- through 10-inch (100 - 250mm), 1.42 in²/ft (30 cm²/m) for pipe diameters 12- through 18-inch (300 - 450 mm) and 1.89 in²/ft (40 cm²/m) for pipe diameters larger than and equal to 24 inches (600 mm). Table 1 below represents ADS standard perforation patterns for AASHTO Class II.

Nominal I.D.	Perforation Type	Maximum Slot Length or Diameter	Maximum Slot Width	Minimum Inlet Area
4" (100 mm)	Slot	0.875" (22 mm)	0.125" (3 mm)	1.0 in ² /ft (21 cm ² /m)
6" (150 mm)	Slot	0.875" (22 mm)	0.125" (3 mm)	1.0 in ² /ft (21 cm ² /m)
8" (200 mm)	Slot	1.18" (30 mm)	0.125" (3 mm)	1.0 in ² /ft (21 cm ² /m)
10" (250 mm)	Slot	1.18" (30 mm)	0.125" (3 mm)	1.0 in ² /ft (21 cm ² /m)
12" (300 mm)	Circular	0.313" (8 mm)	-	1.5 in ² /ft (32 cm ² /m)
15" (375 mm)	Circular	0.313" (8 mm)	-	1.5 in ² /ft (32 cm ² /m)
18" (450 mm)	Circular	0.313" (8 mm)	-	1.5 in ² /ft (32 cm ² /m)
24" (600 mm)	Circular	0.313" (8 mm)	-	2.0 in ² /ft (42 cm ² /m)
30" (750 mm)	Circular	0.375" (9.5 mm)	-	2.0 in ² /ft (42 cm ² /m)
36" (900 mm)	Circular	0.375" (9.5 mm)	-	2.0 in ² /ft (42 cm ² /m)
42" (1050 mm)	Circular	0.375" (9.5 mm)	-	2.0 in ² /ft (42 cm ² /m)
48" (1200 mm)	Circular	0.375" (9.5 mm)	-	2.0 in ² /ft (42 cm ² /m)
54" (1350 mm)	Circular	0.375" (9.5 mm)	-	2.0 in ² /ft (42 cm ² /m)
60" (1500 mm)	Circular	0.375" (9.5 mm)	-	2.0 in ² /ft (42 cm ² /m)

Figure 1

AASHTO Class II Perforation Patterns

Note: Actual pattern may vary by region, however all patterns meet the AASHTO and ASTM minimum requirements for the open inlet area.

4" – 10"
PIPE DIAMETERS

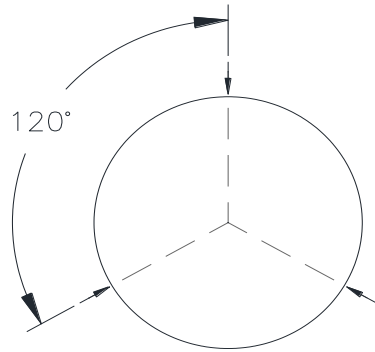

3 AT 120°

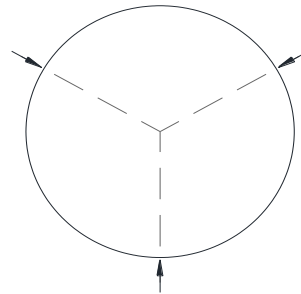

ROTATED
EVERY VALLEY

12" – 18"
PIPE DIAMETERS

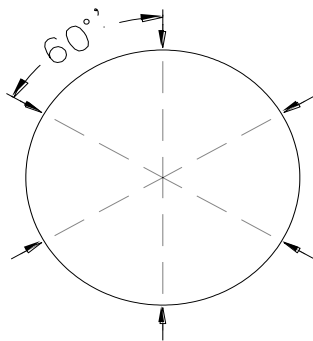

** NUMBER OF HOLES AROUND
CIRCUMFERENCE VARIES BASED ON
DIAMETER AND REGION **

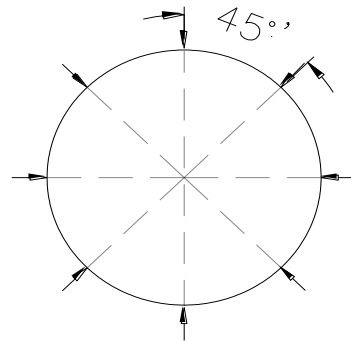

** NUMBER OF HOLES AROUND
CIRCUMFERENCE VARIES BASED ON
DIAMETER AND REGION **

24"
PIPE DIAMETERS

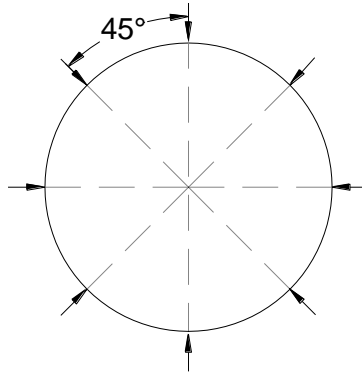

30"
PIPE DIAMETERS

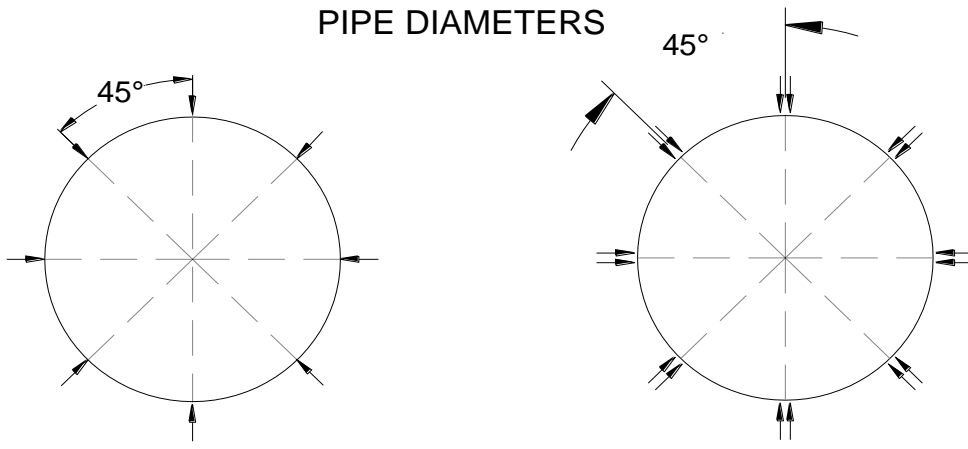

2 AT EVERY 45°

** NUMBER OF HOLES AROUND CIRCUMFERENCE
VARIES BASED ON DIAMETER AND REGION**

36" - 60"
PIPE DIAMETERS

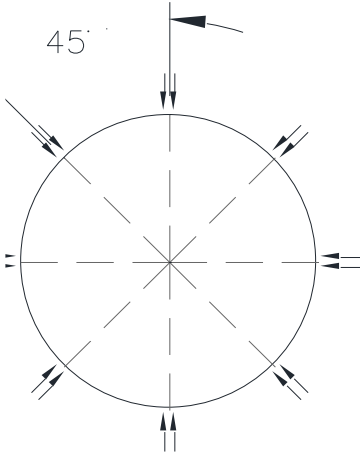

2 AT EVERY 45°

AASHTO Class I Perforation

Please contact your local ADS representative before specifying or ordering pipe with a Class I perforation pattern to verify its availability. The following terminology is derived from the applicable AASHTO specification. The perforations shall be approximately circular and arranged in rows parallel to the axis of the pipe. The locations of the perforations shall be in the valley of the outside of every corrugation. The perforations shall be arranged in two equal groups placed symmetrically on either side of the lower half of the pipe. Diameters 4"-10" are not available in Class I patterns, however your local ADS representative may be contacted to verify whether your custom pattern can be provided.

Nominal I.D.	Min. No. of Rows of Perforations	Maximum Perforation Hole Diameter	Maximum Perforation Hole Diameter	"H" Maximum	"L" Minimum	Inlet Area*
12" (300 mm)	6	0.40" (10 mm)	0.20" (5 mm)	5.5" (138 mm)	7.6" (192 mm)	1.2 in ² /ft (24.3 cm ² /m)
15" (375 mm)	6	0.40" (10 mm)	0.20" (5 mm)	6.8" (172 mm)	9.5" (240 mm)	0.9 in ² /ft (18.4 cm ² /m)
18" (450 mm)	6	0.40" (10 mm)	0.20" (5 mm)	8.2" (207 mm)	11.4" (288 mm)	0.8 in ² /ft (16.0 cm ² /m)
24" (600 mm)	8	0.40" (10 mm)	0.20" (5 mm)	10.9" (276 mm)	15.2" (384 mm)	0.9 in ² /ft (19.2 cm ² /m)
30" (750 mm)	8	0.40" (10 mm)	0.20" (5 mm)	13.6" (345 mm)	18.9" (480 mm)	0.7 in ² /ft (13.8 cm ² /m)
36" (900 mm)	8	0.40" (10 mm)	0.20" (5 mm)	16.3" (414 mm)	22.7" (576 mm)	0.6 in ² /ft (11.7 cm ² /m)
42" (1050 mm)	8	0.40" (10 mm)	0.20" (5 mm)	19.0" (483 mm)	26.5" (672 mm)	0.6 in ² /ft (12.8 cm ² /m)
48" (1200 mm)	8	0.40" (10 mm)	0.20" (5 mm)	21.8" (552 mm)	30.3" (768 mm)	0.6 in ² /ft (12.0 cm ² /m)
60" (1500 mm)	8	0.40" (10 mm)	0.20" (5 mm)	27.2" (690 mm)	37.8" (960 mm)	0.5 in ² /ft (10.1 cm ² /m)

*No minimum Inlet Area requirements from AASHTO M294. Value based on required minimum perforation hole diameter and the minimum number of perforation rows per AASHTO M294.

Figure 2
AASHTO Class I Perforation Patterns

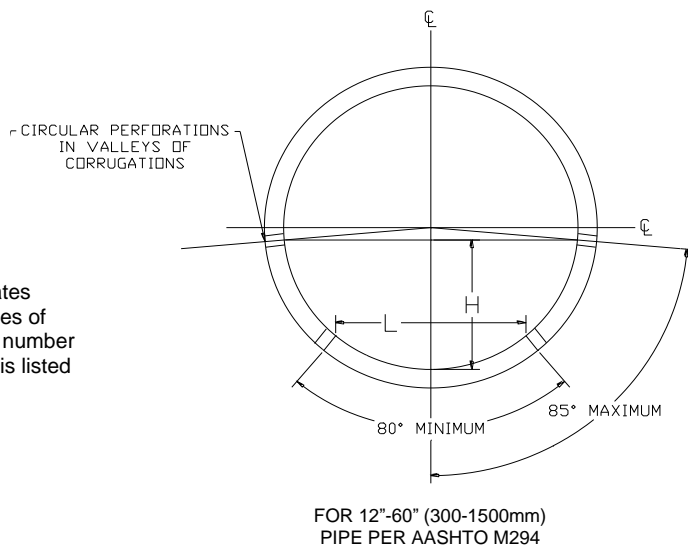

NOTE: Diagram illustrates measurements for values of "H" and "L" – minimum number of rows of perforations is listed in table above.



Technical Note

TN 1.02 Single Wall HDPE Perforation Patterns

Nominal I.D.	Perforation Type	Maximum Slot Length or Diameter	Maximum Slot Width	Minimum Inlet Area	Pattern Type
3" (75 mm)	Slot	0.875" (22 mm)	0.120" (3 mm)	1.0 in ² /ft (21 cm ² /m)	A
3" (75 mm)	Fine Slot	0.875" (22 mm)	0.015" (0.4 mm)	0.3 in ² /ft (6 cm ² /m)	A
4" (100 mm)	Slot	0.875" (22 mm)	0.120" (3 mm)	1.0 in ² /ft (21 cm ² /m)	B
4" (100 mm)	Fine Slot	0.875" (22 mm)	0.015" (0.4 mm)	0.3 in ² /ft (6 cm ² /m)	B
5" (125 mm)	Slot	0.875" (22 mm)	0.120" (3 mm)	1.0 in ² /ft (21 cm ² /m)	B
5" (125 mm)	Fine Slot	0.875" (22 mm)	0.015" (0.4 mm)	0.3 in ² /ft (6 cm ² /m)	B
6" (150 mm)	Slot	0.875" (22 mm)	0.120" (3 mm)	1.0 in ² /ft (21 cm ² /m)	B
6" (150 mm)	Fine Slot	0.875" (22 mm)	0.015" (0.4mm)	0.3 in ² /ft (6 cm ² /m)	B
8" (200 mm)	Slot	1.18" (30 mm)	0.120" (3 mm)	1.0 in ² /ft (21 cm ² /m)	B
10" (250 mm)	Slot	1.18" (30 mm)	0.120" (3 mm)	1.0 in ² /ft (21 cm ² /m)	B
12" (300 mm)	Slot	1.50" (38 mm)	0.118" (3 mm)	1.5 in ² /ft (32 cm ² /m)	B
12" (300 mm)	Circular	0.313" (8 mm)	-	1.5 in ² /ft (32 cm ² /m)	C
15" (375 mm)	Circular	0.313" (8 mm)	-	1.5 in ² /ft (32 cm ² /m)	C
18" (450 mm)	Circular	0.313" (8 mm)	-	1.5 in ² /ft (32 cm ² /m)	C
24" (600 mm)	Circular	0.313" (8 mm)	-	2.0 in ² /ft (42 cm ² /m)	D

The data provided above is representative of the most common pattern supplied by ADS. Actual perforation count and dimensions may vary based on regional-specific requirements; product will still comply with respective product ASTM and AASHTO product standards.

TYPE A PATTERN

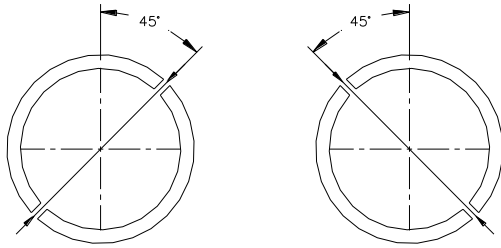

2 SLOT PATTERN
PERFORATIONS
ROTATED 90° EVERY
OTHER VALLEY

TYPE B PATTERN

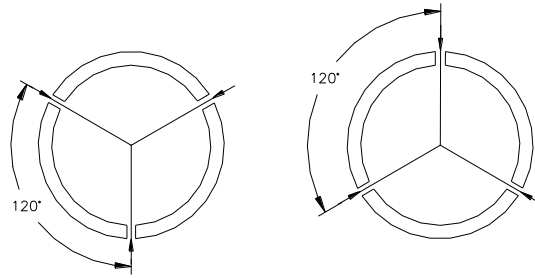

3 SLOT PATTERN
PERFORATIONS
ROTATED 60° EVERY
OTHER VALLEY

TYPE C PATTERN

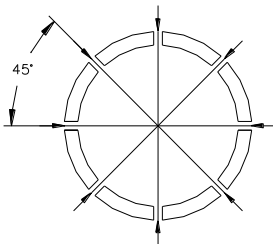

8 HOLE PATTERN

TYPE D PATTERN

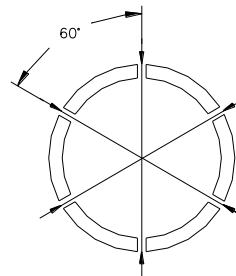

6 HOLE PATTERN



Technical Note

TN 1.03 Storm Water Quality Units

Introduction

The ADS Storm Water Quality Unit (SWQU) is designed to remove pollutants from storm water during a storm event. ADS has modified its standard N-12[®] pipe to include weir plates at certain locations and heights to help facilitate sediment and oil removal from storm water. A bypass pipe is included in the storm water quality unit, so the system can focus on treating the “first flush”. After the “first flush” has entered the system, the bypass pipe directs high volumes of storm water around the system.

Storm Water Treatment

The ADS SWQU is designed to treat the “first flush” of a storm event or lower volume storms. First flush refers to the initial runoff generated by a storm event. Relatively high concentrations of pollutants may be flushed into storm drains during a first flush. First flush pollutant concentrations are relatively high at the beginning of storms and drop off over time. Although it may vary based on site conditions, the first flush can contain over 80% of the pollutants that will be transported off a site.

It is a widely accepted practice to provide treatment for the first flush as opposed to treating the entire design storm event. Treating the first flush provides a high level of storm water quality at a much lower cost to the developer. The storm water runoff, which follows the first flush, is generally assumed to be relatively clean in comparison. Providing treatment for this “clean water” can often double, if not triple, the cost of treatment at a minimum. By treating the first flush one can provide a great benefit to the environment at a reasonable cost.

The treatment of the contaminated storm water is achieved through the use of weir plates installed at various locations within the unit. The storm water will enter the first chamber, or Sediment Chamber, which consists of an upright weir for trapping sediment. A second chamber, or Oil Chamber, uses an inverted weir to trap oils, grease, and debris. Figure 1 illustrates the typical layout of a SWQU. Field and lab testing of the unit indicate the following removal efficiencies:

- 80% Total Suspended Solids removal
- Greater than 43% Total Phosphorous removal
- 72% Heavy Metals removal
- Removal of floatable debris such as oils and greases

Testing reports and summaries are available by contacting your ADS Representative or Application Engineering. The flow through the unit is controlled at the outlet of the unit by using an orifice, thus categorizing the Storm Water Quality Unit as an outlet-controlled system. The design methodology behind outlet control is described in the entitled section Sizing a Storm Water Quality Unit.

When greater storm volumes are encountered, the addition of an external bypass allows the excess water to bypass the unit so as not to cause turbulent flow and possible resuspension of contaminants in the unit. This allows the lower volume storms and first flush events, where most contaminants are flushed off the pavement, to be trapped by the unit and remain there until the unit is cleaned.

Figure 1
Storm Water Quality Unit

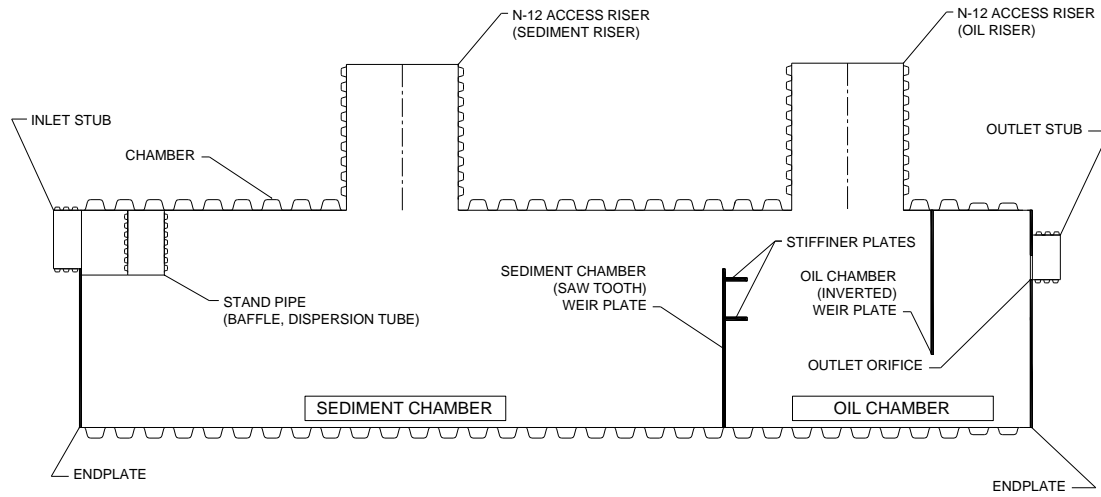

Sizing a Storm Water Quality Unit

The ADS Storm Water Quality Unit is designed using the fundamental principles of Stoke's Law and a standard orifice equation. Stoke's Law is used to determine the settling velocity of a known particle size. The settling velocity can then be used to calculate the settling time, which is the time it takes a particle to fall a distance equal to the inlet pipe diameter plus 2 inches (50mm). The velocity through the chamber is found by dividing the treated flow rate by the cross-sectional area of the storm water quality unit. The length of the sediment chamber can now be determined by taking the velocity through the chamber and multiplying by the settling time. After the length of the sediment chamber is established, the size of the orifice must be calculated. The orifice controls the amount of water entering the water quality unit. Once the treated flow rate is reached, excess water is diverted to the bypass. A standard orifice equation is used to find the diameter of the orifice. Example 1 provides an example calculation for sizing a Storm Water Quality Unit.

Example 1

Particle size: 140 sieve

Treated flow rate, $Q_{\text{treat}} = 2.26$ CFS

Assume 48 in. Water Quality Unit with 12 in inlet pipe

Stoke's Law to determine settling velocity:

$$V_{\text{settling}} = 2gr^2 \frac{(\gamma_1 - \gamma_2)}{(9\mu)}$$

V_{settling} : Velocity of fall for a particle (ft/sec)

g : Acceleration of gravity = 32.2ft/ sec²

r : Equivalent radius of particle

140 sieve: $r = 0.000175$ ft

200 sieve: $r = 0.000125$ ft

γ_1 : Density of particle (soil) = 3.69 slug/ ft³

γ_2 : Density of medium (water) = 1.94 slug/ ft³

μ : Viscosity of medium (water at 20° C) = 2.09 x 10⁻⁵ lbf-sec/ ft²

$$V_{setling} = 2 \left(32.2 \frac{ft}{sec^2} \right) (0.000175 ft)^2 \left(\frac{\left(3.69 \frac{slug}{ft^3} - 1.94 \frac{slug}{ft^3} \right)}{\left(9 \left(2.09 \times 10^{-5} \frac{lbf \cdot sec}{ft^2} \right) \right)} \right) = 0.018 ft/sec$$

$$V_{setling} = 0.018 ft/sec$$

Settling Time:

$$T_{setling} = \frac{SD}{V_{setling}}$$

$T_{setling}$: Settling time for a particle of known size: (sec)

SD : Settling distance, inlet pipe diameter + 2 in. = (12.15 in. + 2 in.) = 1.18 ft

$V_{setling}$: Settling velocity = 0.018 ft/sec

$$T_{setling} = \frac{1.18 ft.}{0.018 \frac{ft}{sec}} = 66 sec$$

$$T_{setling} = 66 sec$$

Velocity through Sediment Chamber:

$$V_{SC} = \frac{Q_{treat}}{A_{WQU}}$$

V_{SC} : Velocity through the sediment chamber (ft/sec)

Q_{treat} : Flow at which one wants to treat for water quality = 2.26 CFS

A_{WQU} : Cross sectional area of the water quality unit = $\frac{\pi}{4} D^2 = \frac{\pi}{4} (4 ft.)^2 = 12.57 ft^2$

$$V_{SC} = \frac{2.26 CFS}{12.57 ft^2} = 0.180 \frac{ft}{sec}$$

$$V_{SC} = 0.180 ft/sec$$

Length of Sediment Chamber:

$$L_{\text{sediment}} = (V_{SC})(T_{\text{settling}})$$

L_{sediment} : Length of the sediment chamber (ft.)

V_{SC} : Velocity through the sediment chamber = 0.180 ft/sec

T_{settling} : Settling time for a particle of known size = 65.56 sec

$$L_{\text{sediment}} = \left(0.180 \frac{\text{ft}}{\text{sec}}\right)(66 \text{ sec}) = 12 \text{ ft}$$

$$L_{\text{sediment}} = 12 \text{ ft}$$

Orifice Equation:

$$Q_{\text{treat}} = (C_d)(A_0)\sqrt{2gh_0}$$

Q_{treat} : Treated flow rate = 2.26 CFS

C_d : Coefficient = 0.56

A_0 : Area of the orifice = $\frac{\pi}{4}d_0^2$ (ft²)

g : Acceleration of gravity = 32.2 ft/sec²

h_0 : Head pressure ft = $SD = 1.18$ ft

Solving the equation for the diameter of the orifice:

$$d_0 = \left[\frac{4Q_{\text{treat}}}{0.56\pi(2gh_0)^{1/2}} \right]^{1/2} = \left[\frac{4(2.26\text{CFS})}{0.56\pi \left(2 \left(32.2 \frac{\text{ft}}{\text{sec}^2} \right) 1.18 \text{ ft} \right)^{1/2}} \right]^{1/2} = 0.77 \text{ ft.}$$

$$d_0 = 0.77\text{ft.}, \text{ Use } 9.24'' \text{ orifice}$$

NOTE: Although the Water Quality Unit is installed level, there is a drop across the unit to provide for proper head pressure and system performance.

Conclusion

The ADS SWQU provides a cost-efficient treatment option for a variety of applications while achieving removal efficiencies that meet or exceed most local minimum requirements for storm water treatment. The treatment of both settling and floating pollutants provides a good first level management technique that offers the user the opportunity to use the device in either a stand- alone configuration or as a step in a treatment train.



Technical Note

TN 1.04 Testing of Storm Water Quality Units

Introduction

For the last 20 years storm water management has become an increasingly important issue in the United States. This has affected not only the larger metropolitan communities but has begun to become important in smaller rural communities around the country. The areas of interest for these projects are not only storm water quantity but also storm water quality. The ADS Storm Water Quality Unit (SWQU) provides the first step in the treatment train: removal of floating debris, suspended solids, and contaminants.

Development

The ADS SWQU was developed to provide a simple, effective method for the control of storm water quality. The basic design of the unit is an oil grit separator. The unit consists of an upright weir for trapping sediment and an additional inverted weir for trapping the floatable particles such as oils, grease, and debris. This technology has been around for several years and is very effective until higher event storms. During intense storm events, oil grit separators are subject to resuspension of solids and washout of floating particles. Although the efficiency of the early units was fairly high, they had difficulty retaining the particles that were trapped during high volume storm events.

The ADS SWQU utilizes the same technology but improves upon it to provide a more efficient yet still simple method of controlling water quality. The addition of an external bypass allows higher storm volumes to be bypassed *around* the unit without passing through the unit and causing turbulent flow. This allows the lower volume storms — where most contaminants are flushed off the pavement — to be trapped by the unit and remain there until the unit is cleaned out. In addition, the ADS SWQU is constructed of High Density Polyethylene (HDPE) which is inert and much more chemical resistant than the standard concrete Oil Grit Separators previously used for these applications.

Design

A full discussion of the SWQU design methodology is available in Technical Note 1.01: *Water Quality Units - EPA Phase II, Best Management Practices*. In summary, the SWQU utilizes Stoke's law in order to predict removal efficiencies based on particle size. The units are designed with a sediment chamber, a floatable chamber, and an outlet chamber to provide the stormwater treatment ability of the unit. All flows above the velocity required are routed through the bypass line to prevent the resuspension and removal of trapped materials from the unit. See Figure 1 for a layout of a typical SWQU.

Figure 1

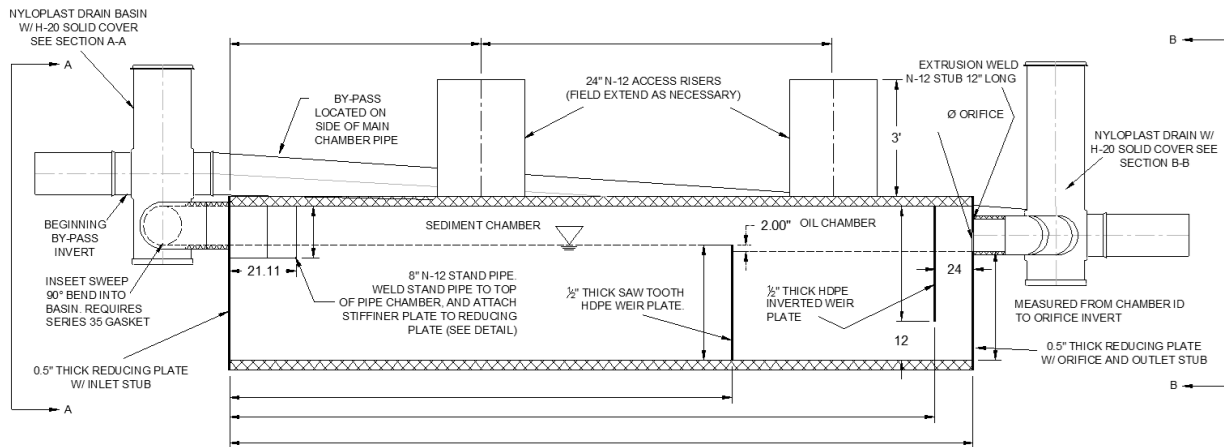

Laboratory Testing and Research

As with any device designed to treat water quality, testing should be performed to determine the removal rates and efficiencies of the device. The ADS SWQU has been subjected to of several different testing protocols to determine the removal rates for both total suspended solids (TSS) and oil and hydrocarbons. Testing has been conducted in both the laboratory and the field. The following summarizes the testing which has been initiated or completed on the ADS SWQU:

Ohio University Scale Model Lab Testing

Testing consists of a scale model test loop including the Water Quality Unit and the bypass line. The model tested was a 12" diameter Water Quality Unit with appropriate scaled appurtenances. This testing was completed in September of 2003. The model was tested for both sediment and oil removal during the evaluation. A layout of the test loop is shown below in Figure 2.

Figure 2

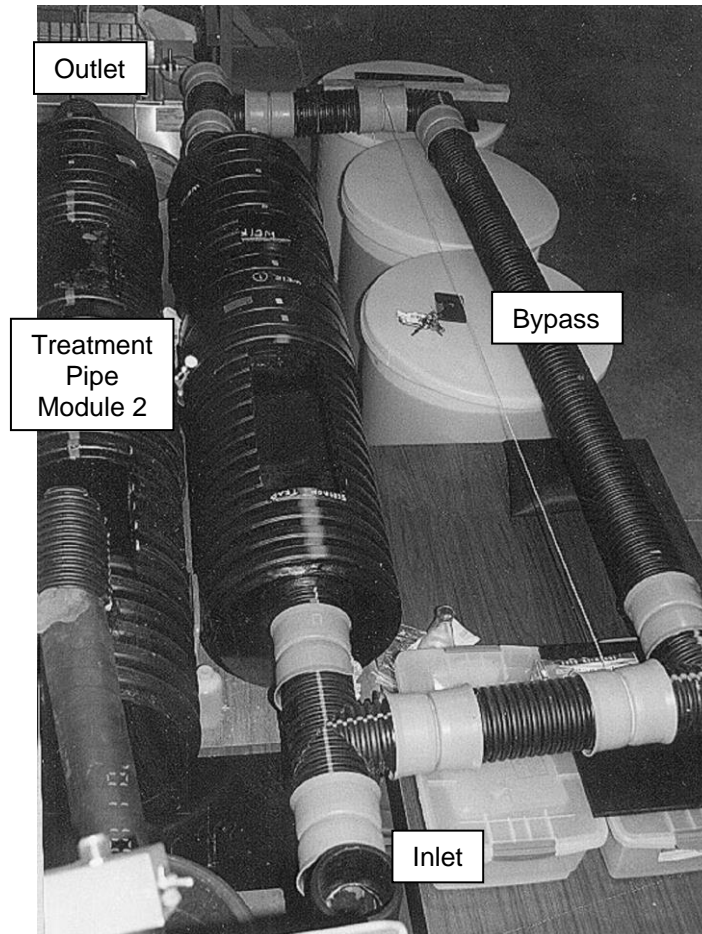

Two different soils were used for the evaluation in the Ohio University Lab study. The soils are shown as Type 1 and Type 2. The Type 1 soil contains particles which are generally smaller than the 200 sieve or 75 micron size. The Type 2 soil contains particles which are generally larger than the 200 sieve or 75 micron size. Sieve analyses for both soil types are shown below in Figure 3 and 4. The vertical lines represent the 140 sieve and 200 sieve particle sizes.

Figure 3

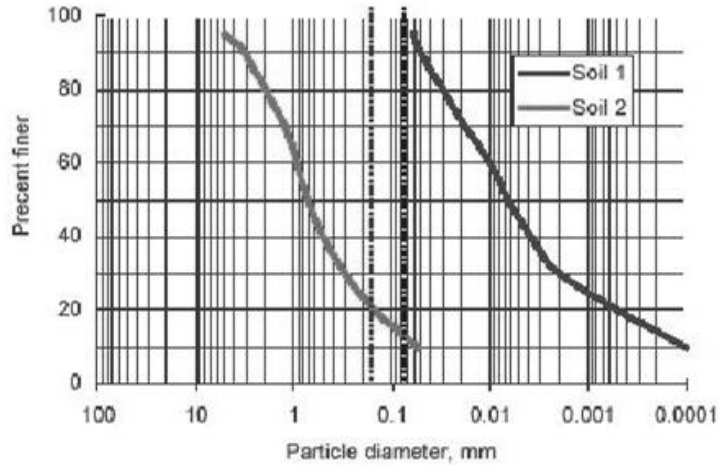

Soil Type 1 showed removal rates of 50 – 60% in the higher flow regimes. This would be expected for this soil type, given the smaller particle sizes and the flow rates used in the experiment. In tests with lower flow rates, the removal rates increased as the residence time increased. This again would be expected with any soil distribution which might be used in the system. Soil Type 1, for the most part, consisted of very fine particles such as silts and clays. The performance of the SWQU using these particle sizes was excellent considering they were outside the design of the unit. A graph of the removal rates for both soil types can be seen in Figure 4.

Figure 4

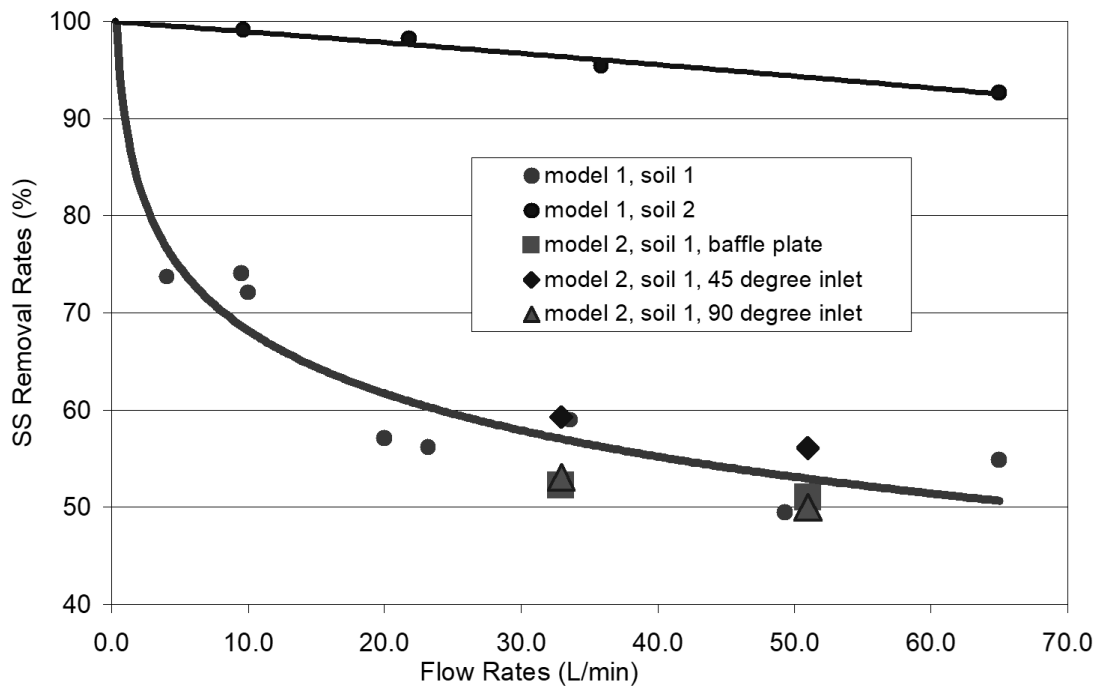

Soil Type 2 consisted of particles which generally were larger than the 200 sieve and larger than the soils in Type 1. These soils, because of their larger size, allowed for less residence time in the unit and still maintained high removal rates. The removal rates for these particle sizes were over 90% for the flow regimes tested. The soils which were present in this classification range were particles which are targeted for removal in the ADS Water Quality Unit.

Scaling of Lab Data

Laboratory testing is a convenient method for testing practical theories and design principles. It provides a method to use a controlled environment and change the appropriate variables to try and achieve the desired results. This is especially true when scale models can be used to reduce the cost and logistics of testing large devices. Once the testing is complete it must be scaled to the appropriate standard to produce results which can be predicted in the real world. In the case of the ADS SWQU it requires that the unit be scaled up in order for flow rates and SWQU sizes to be appropriate for application.

Two methods for scaling the laboratory data are discussed here. They are the “surface load method” and the “horizontal flow velocity” method.

The surface flow method is defined by the following equation:

$$\text{Surface load} = \text{overflow rate} = \text{flow rate} / \text{surface area}$$

(Tchobanoglous and Franklin, 1991)

The horizontal flow velocity simply takes the runoff rate and converts it to a flow based on pipe diameter to get a flow velocity. If both methods are used, a chart comparing field rainfall intensity to laboratory flow data can be developed, as shown below in Figure 5.

Figure 5

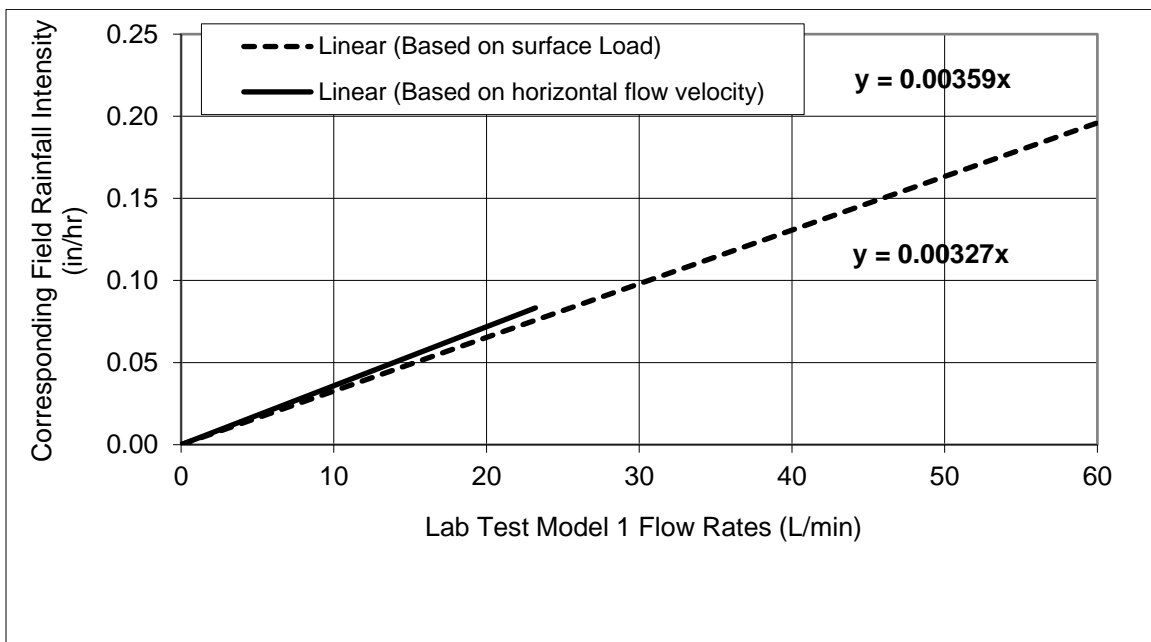

Alden Labs Maine DEP Laboratory Testing Protocol:

In addition to the scale model testing, which was performed at Ohio University, full scale laboratory testing was performed at Alden Laboratories in Holden, Mass. Alden Labs tested the SWQU for conformance with the Maine Department of Environmental Protection Protocol for total suspended solids (TSS) removal. The Maine DEP protocol was put in place to provide a fair and unbiased mechanism for the evaluation of competitive manufactured water quality treatment devices. The protocol calls for the injection of a test media into the treatment flow at a predetermined concentration. The concentration is held at these levels and required residence time is computed. Samples are taken for background levels, influent levels, and effluent levels. The material collected in each sample is then filtered out and appropriately dried. Once the material is dried, it is weighed, and the concentration of the total suspended solids is determined.

For the ADS SWQU, a 60-inch diameter, full scale unit was used. The unit was placed in a test loop at Alden Labs which consisted of the SWQU and the necessary support structure to run the tests. The testing was conducted on a standard 60" unit with a few small modifications to provide for accessibility and conformance to the requirements of the system loop. The modifications included an increase in the size of the risers to 36", the introduction of flanges on the inlet and outlet sides of the unit, and the insertion of small diameter pipe at the invert on the inlet and outlet side. The 36" risers were added primarily as inspection risers and for access into the system in case modifications or changes in the monitoring and testing procedure were required. In addition, the large risers provided easier access for the system to be cleaned out between tests. The flanges were provided on the inlet and outlet side of the unit to allow the SWQU to be inserted into the test loop, and to provide a watertight connection for the testing procedure. The small diameter pipe at the invert was put in place to allow the unit to be easily drained and cleaned out for subsequent tests at differing flow rates. In all other regards the unit tested was a standard ADS SWQU with appropriate weir spacing and weir heights. A drawing of the unit is shown in Figures 6A & B.

Figure 6A

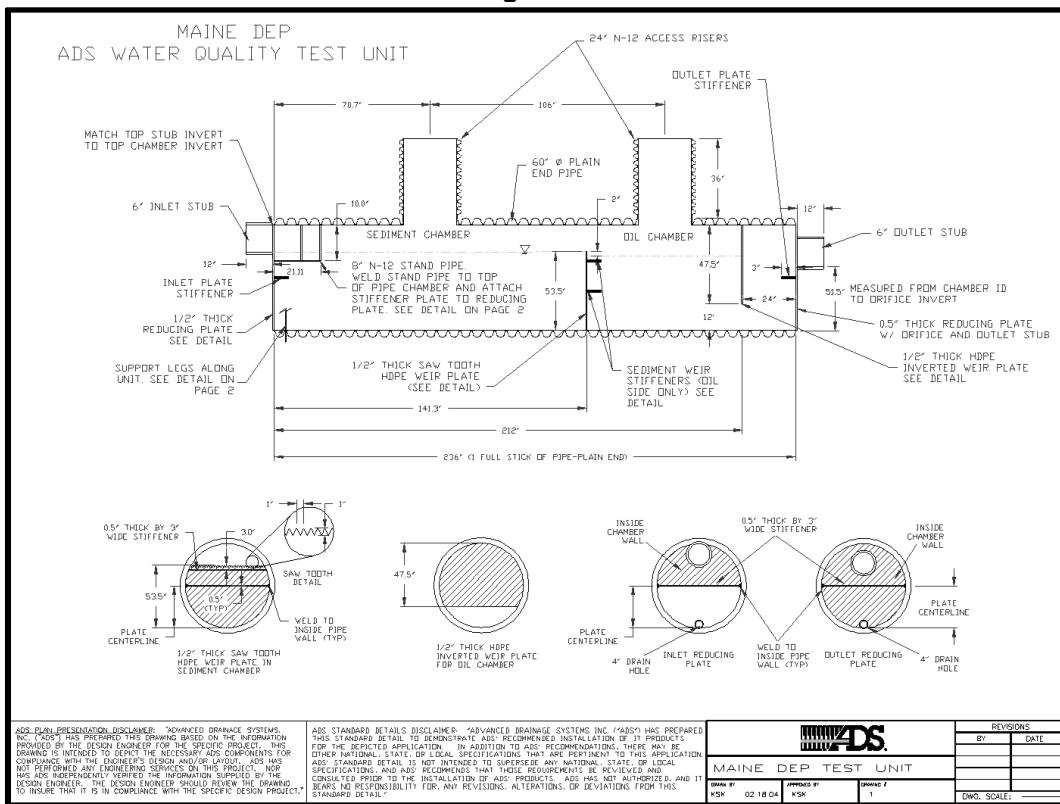
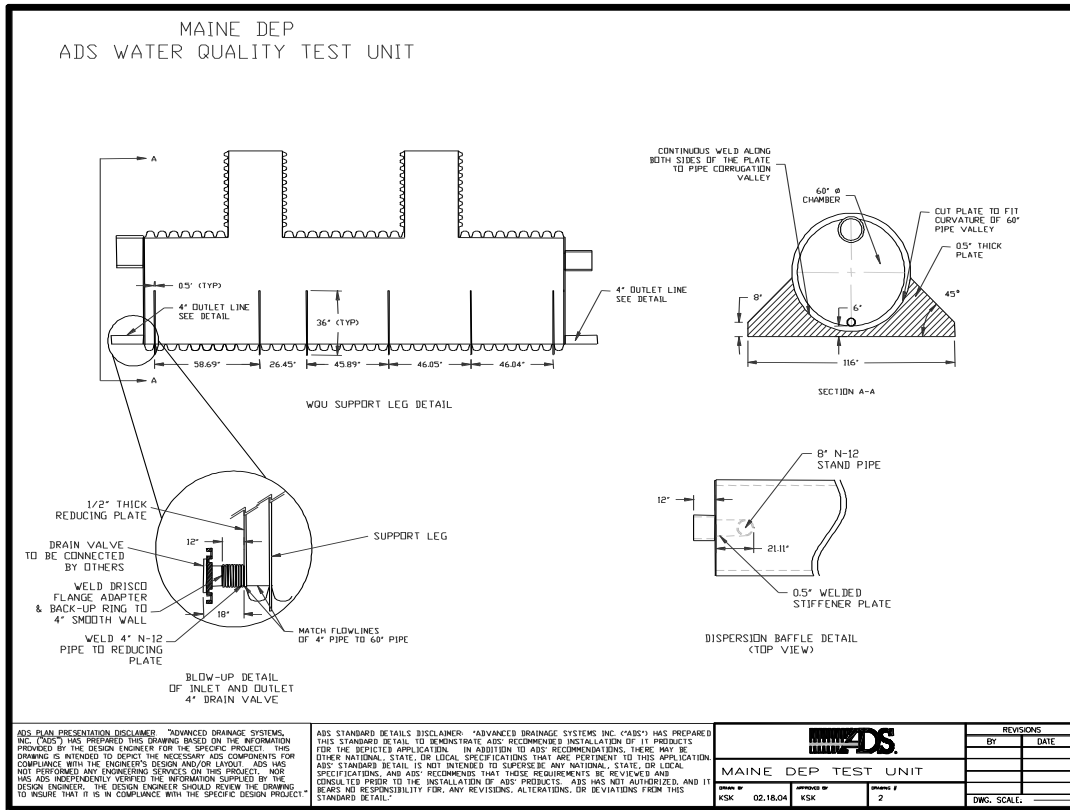

Figure 6B



The testing of the unit was run at various flow rates in order to determine the variance in the levels of efficiency for the SWQU based on flow rate and residence time. The concentration of sediment was approximately 250 mg/L. Each test run consisted of 5 inlet and outlet sample pairs to provide an adequate data set for the testing on the unit. The timing of the samples was such that the residence time in the unit was taken into account to provide samples which were coordinated with each other. A picture of the test unit in the testing loop is shown in Figure 7.

Figure 7



The test media used consisted of two different sands manufactured by U.S. Silica. The F-95 sand has a larger particle size and the OK-110 sand has a smaller particle size. The sieve analysis for each product is shown Table 1.

Table 1

U.S Silica Test Media

US Std. Sieve	% Retained	
	F-95	OK-110
30		0
40	<1	0
50	1	0
70	9	0
100	60	1
120		15
140	42	48
170		24.2
200	15	9.7
270	3	1.9
Pan	<1	0.2

Multiple tests were conducted on the unit to provide a comprehensive analysis of the performance of the unit at various flow rates. The targeted flow rate based on Stoke's Law for the 60-inch Water Quality Unit is 1.47 cfs. Tests were conducted on the unit above and below the unit's anticipated flow rate to determine the performance limitations. For the 1.5 cfs. test, the average removal rate for the OK-110 sand was 88.3%. As a result of this testing, a scaling factor can be used to correlate the results with different size SWQU's and indicates that the design for the units is accurate. Scaling to other size units is accomplished by the following equation:

$$Q_{treatment} = (0.016949 \text{ cfs/ ft}^2)(area)$$

As a result, the treatment rates from testing at Alden Labs compare favorably to our recommendations for flow rates through the unit based on the theoretical design. Table 2 shows the tested flow rates compared to the recommended rate.

Table 2

Product No.	Minimum Treatment Chamber Area (sf)	Maximum treated flow (cfs) (tested)	Design Treated Flow (cfs) (recommended)
3620WQB	55.50	0.94	0.7
3640WQB	111.00	1.88	1.6
4220WQB	64.43	1.09	0.86
4240WQB	128.86	2.18	1.83
4820WQB	71.40	1.21	1.13
4840WQB	142.80	2.42	2.39
6020WQB	88.50	1.50	1.47
6040WQB	177.00	3.00	3.12

For design purposes the Design Treated Flow rate should be used. As a follow up to the total suspended solids testing, further study of the Water Quality Unit was conducted to determine the oil removal efficiency of the unit.

Alden Labs Oil Removal Testing

The same 60-inch diameter SWQU that was used in the total suspended solids removal testing at Alden Labs was also used for the oil removal study. The unit was again slightly modified to provide for an accurate determination of the oil removal efficiency of the unit. A skimmer wall, retraction assembly, and sidewall blockage areas were added to confine the oil collected so that it could be easily identified

Soybean based vegetable oil was used as the test medium. The density of the oil was approximately 0.92 g/ml. Oil was introduced into the system by use of a pump, which was calibrated prior to testing to determine the relationship between pump speed and the oil feed rate. Once again, the background levels were recorded to determine any influence from the water used in the system. The SWQU was tested with flow rates ranging from 0.5 cfs. to 2 cfs. The oil injection concentration ranged from 50 to 100mg/L. The tests were run for a period of 1 to 2 hours, depending on the influent flow, until approximately 10 liters of oil were injected into the unit. After the flow oil was discontinued, the unit was allowed to operate for a period of time to make sure that all of the oil had been injected into the unit and that the water volume carrying the oil had passed through. Flow rates and removal efficiencies are shown in Table 3.

Table 3

Oil Removal Efficiencies

Flow Rate (cfs)	Removal Efficiency (%)
0.5	95
1	87
1.5	80
2	57

Once again, the flow rate targeted for design purposes is 1.5 cfs for the 60" unit. This would show an 80% removal rate. The scaling of this information remains the same as shown in the previous section.

Field Testing and Research

Due to the complexities of field research and the dependence on the weather for cooperation, field testing requires more time and resources. Also, because of the lack of control on all of the variables, the results can be somewhat inconsistent and often require more analysis when completed. However, the field data and testing when approached correctly, can provide valuable information for further enhancements and improvements. The SWQU is being tested in several field installations. Because of the time required to complete these studies none of the current field studies have been completed, but some of them are yielding preliminary information. The studies currently underway are as follows:

University of New Hampshire Center for Stormwater Technology Nashville Study of Eight Water Quality Units Mississippi Testing of Water Quality Units

The status of each study is summarized below.

University of New Hampshire Center for Stormwater Technology

This study consists of a Water Quality Unit and a perforated retention system in series on the site. The site is a study area for several different manufactured and natural stormwater treatment and control devices. The entire 8 acres that the property is located on is the drainage area from a parking lot for the University. The runoff collected from the site is urban and generates sediment, oil and grease. The storm water is metered to all the different devices on the site so that each treatment device receives 1 cfs. The stormwater is sampled on the influent and effluent sides to provide TSS and Floatable Removal Rate. Several other parameters are also tested at this site, including heavy metals, organics, and nutrients. The samplers used are automatic and the information is collected centrally for ease of access.

In addition, the site has been studied from a hydrologic standpoint to provide detailed data on rainfall and runoff rates. From this data, storms which provide adequate parameters are selected to provide the sample data set. A full set of data and the parameters for testing are available upon request. Preliminary results are not publicly available at this time.

Nashville Study of Eight Water Quality Units

This study consists of eight Water Quality Units located at various sites around the metro Nashville area. The testing was conducted by Qore Property Sciences and the final report was issued on June 23, 2005. The eight units were each tested for one storm event within each unit's treatment capacity. The samples were collected in accordance with the Technology Acceptance Reciprocity Partnership (TARP) Protocol for Stormwater BMP demonstrations. The testing was done in accordance with ASTM 3977-97, Standard Test Method for Determining Sediment Concentration in Water Samples, for the range of particles specified by Nashville using the No.10 to the No.140 sieve. Results from the testing are shown in the Table 4.

Table 4

Location	Unit Diameter	Sieve #	Weight Retained Influent (Grams)	Weight Retained Effluent (Grams)	Percent Removed
Occupational Health 4300 Sidco Drive	48"	140	8.28	0.14	98
Jim and Nick's BBQ 7004 Charlotte Pike	60"	140	2.99	0.05	98
Autowash 7006 Charlotte Pike	36"	140	1.5	0.3	80
Shurgard Storage 2360 Gallatin Road	48"	140	4.59	0.21	95
Southern Unit: Walgreen's HWY 100 at Old Harding Pike	48"	140	1.81	0.13	93
Taco Bell 2904 Gallatin Road	48"	140	1.21	0.08	93
High Tech Institute 560 Royal Parkway	42"	140	0.88	0.08	91
DMW Expedite 1850 Elm Hill Pike	48"	140	1.22	0.21	83

In addition to the results summarized in Table 4, an analysis of particle sizes ranging from the No.10 to the No.200 sieve was also conducted. The samples taken were in accordance with TARP protocol and ASTM 3977-97 was used to determine the resulting efficiencies. A summary of the results is shown in Table 5.

Table 5

Location	Unit Diameter	Sieve #	Weight Retained Influent (Grams)	Weight Retained Effluent (Grams)	Percent Removed
Occupational Health 4300 Sidco Drive	48"	200	8.29	0.15	98
Jim and Nick's BBQ 7004 Charlotte Pike	60"	200	3.29	0.07	98
Autowash 7006 Charlotte Pike	36"	200	1.7	0.31	82
Shurgard Storage 2360 Gallatin Road	48"	200	4.6	0.21	95
Southern Unit: Walgreen's HWY 100 at Old Harding Pike	48"	200	1.99	0.15	93
Taco Bell 2904 Gallatin Road	48"	200	1.2	0.1	92
High Tech Institute 560 Royal Parkway	42"	200	0.94	0.1	89
DMW Expedite 1850 Elm Hill Pike	48"	200	1.62	0.34	79

Conclusions

The ADS SWQU can provide significant treatment for stormwater quality on a variety of stormwater projects. The treatment of both settling and floating pollutants provides a good first level management technique. This provides the opportunity to use the device in both a stand-alone configuration or as the first step in a treatment train.



Technical Note

TN 1.05 Pipe Joints & Gaskets

Introduction

ADS offers a full line of corrugated pipe products to fit the requirements of nearly any storm drain or gravity flow project and some sanitary sewer and low head pressure project specifications. With several products available to meet many project needs, the following outlines the product characteristics and typical uses of pipe used for storm drainage, sanitary sewer and irrigation to aid in the most efficient selection of an ADS product; specifications with additional information for each pipe product are also available. In some applications when corrosive effluent may be present in the pipe, the gasket material should also be evaluated and will be discussed in the following.

Pipe Products

Two base materials are currently used for ADS products: high density polyethylene (HDPE) and polypropylene (PP). The HDPE products will be black in color, while the PP products will be grey in color. Products used for mainline storm drainage and sanitary sewer will have a dual wall or triple wall profile. Figure 1 illustrates a cross section of the dual and triple wall profiles. Individual product specifications for all ADS pipe products are available in the Drainage Handbook Specifications section, which can be downloaded from www.ads-pipe.com or obtained from an ADS representative.

Figure 1
Dual Wall and Triple Wall Pipe Profiles



For all IB (integral bell) products, a gasketed integral bell and spigot joint, which maintains a constant outside diameter (OD) to avoid additional excavation for the bells, is utilized on 12" – 60" pipe; 4" through 10" pipe comes with a coupler installed by the manufacturer to eliminate the need for additional couplers, but is not manufactured on the pipe as with the IB connection. Products using the IB joint configuration include N-12® ST IB, N-12 WT IB, MEGA-GREEN®, Sanitite®, N-12 HP, SaniTite HP and Low Head pipe.

Gaskets

All ADS gaskets meet the requirements of ASTM F477, "Standard Specification for Elastomeric Seals (Gaskets) for Joining Plastic Pipe." There are two categories of gasket connections required to join ADS products: integral connections and field/fitting connections. Integral connections utilize the manufactured integral bell and spigot (IB) that was described in the preceding pipe product sections. Field couplers or fitting connections use a welded bell that is identifiably larger than the IB joint on unmodified pipe. To allow for easy field modification, a larger valley or saddle gasket must be used when inserting the pipe or fitting into a welded bell. Gaskets are available for soil-tight or watertight performance and should be selected with the aid of an ADS representative to ensure the correct gasket is ordered.

Chemical Resistance of Gaskets

Gasket material must be considered for projects where abnormal chemicals or abnormal concentrations of chemicals are present. Like other common storm water drainage pipe materials, ADS pipe products utilize polyisoprene rubber gaskets manufactured meeting the requirements of ASTM F477. In most cases, this gasket material is resistant to many of the common chemicals found in storm drainage applications. However, there are chemicals that may negatively affect the gasket material. For information on chemical resistance of elastomers commonly used as plastic pipe seals or gaskets, refer to ADS Technical Note 4.01 Chemical Resistance of Polyethylene and Elastomers or Technical Note 4.02 Chemical Resistance of Polypropylene and Elastomers.

Alternative Pipe Gasket Materials

Oil Resistant Gaskets

For applications where resistance to hydrocarbons (oil/gasoline) is important, nitrile rubber may be a suitable gasket material. Nitrile has good resistance to oil, solvent, and hydraulic fluid and has been used for many years in o-ring and hose products. It also demonstrates suitable material properties that make it a desirable material for pipe joints over other oil resistant materials. For projects where a lower level of hydrocarbon resistance may be required, neoprene gaskets may also be a suitable alternative.

EPDM (Ethylene-Propylene) Gaskets

EPDM may be used as a suitable pipe gasket material in environments where acids are present or when the gasket may be exposed to the sun for extended periods of time.

For applications where custom gaskets may be needed, please contact your local ADS representative for pricing and availability.



Technical Note

TN 1.07 Manhole Adapter Guide - SaniTite® HP, HP Storm, N-12® HDPE Pipe

Manhole Connection Basics

Compression Connections

- Gasket is cast into the wall of the manhole at the precaster's facility. Gasket cannot be field installed.
- A-LOK® Premium™ is recommended for all connections. The Premium gasket has higher compression than the A-LOK STM standard gasket, which aids in sealing against the outer wall of SaniTite HP triple wall pipe and the SaniTite HP manhole adapter sleeve for dual wall pipe.
- A-LOK gaskets always need to connect to a smooth surface of pipe – Nyloplast® adapter or ADS adapter sleeves are required when using dual wall pipe. Triple wall pipe requires no adapter.



Boot Connections:

- Gasket can be installed by the precaster or field-installed by the contractor. The precaster will form the required hole in the structure and either the precaster or contractor will install the boot.
- Preferred manufacturers are Press Seal® (PSX Direct Drive) and Trelleborg (Kor-n-Seal®).
- Boots always need to connect to a smooth surface. You can connect to a dual wall pipe with an installed corrugated pipe adapter (valley fill gasket) or a Manhole adapter sleeve.

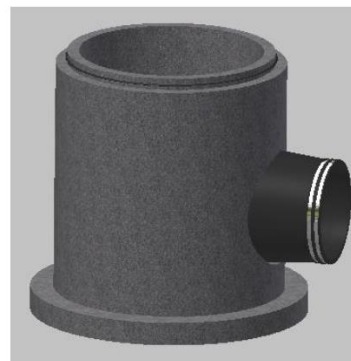

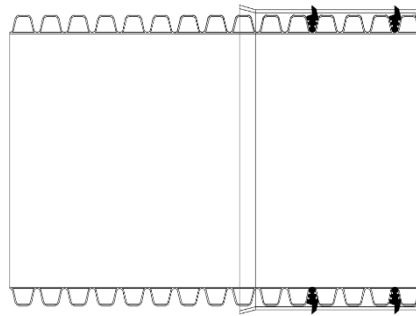
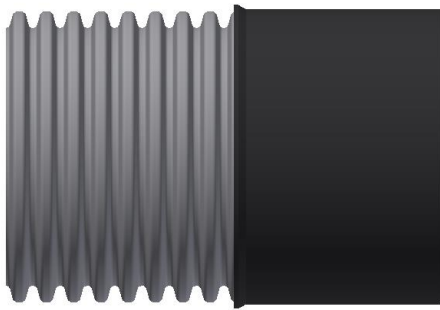

Sleeve Manhole Adapter

Boot or Compression Connection

For HP & HDPE
12" - 24" (XX22AAPP)
Sanitary or Storm Joint

Not Available for 21"

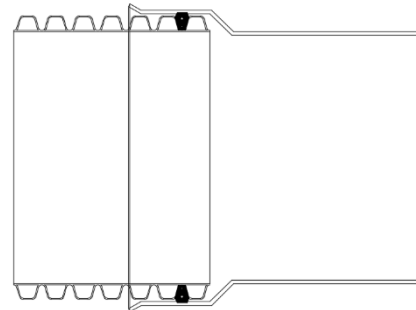
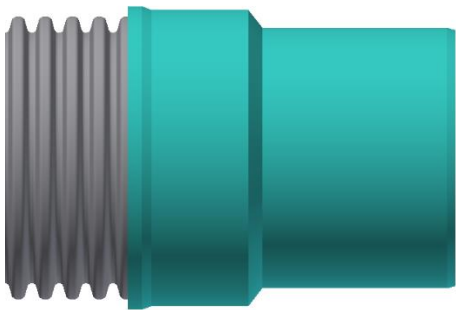

Nyloplast® PVC Manhole Adapter

Same OD as SDR35

Boot or Compression Connection

HP { 12" - 24" (XX57AGHPU2) Sanitary Joint
12" - 30" (XX57AGHPU) Storm Joint

HDPE { 12" - 30" (XX77AGU) Storm Joint

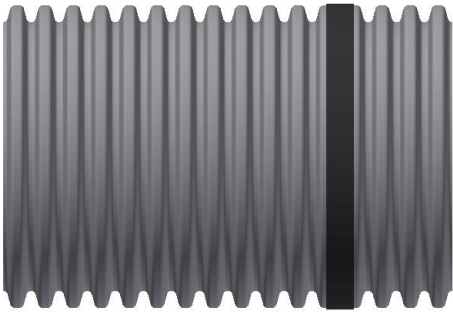

Corrugated Pipe Adapter Gasket

Boot Connection Only
(XX50PS)

12" – 30" Sanitary or Storm Joint
36" – 60" Storm Joint

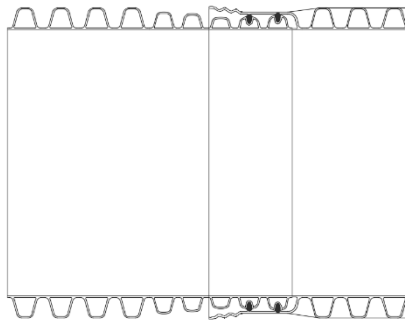
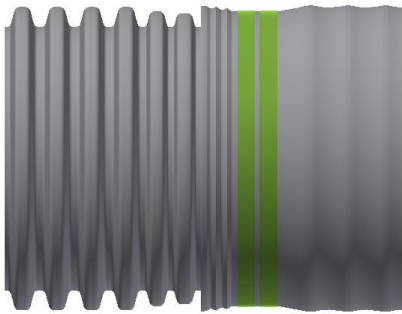

SaniTite HP TW to HP Storm DW

Boot or Compression Connection

30" – 60" Dual Wall

Storm Joint

Coordinate with plant to ensure correct gasket
for compatibility is installed prior to shipment.

CONSULT ADS SERIES 200 STANDARD DETAILS



The ADS logo, SaniTite HP, N-12 and the Green Stripe are registered trademarks of Advanced Drainage Systems, Inc.
Nyloplast® is a registered trademark of Nyloplast, Inc.
© 2022 Advanced Drainage Systems, Inc. TN 1.07 April 2022

adspipe.com
1-800-821-6710

Technical Note

TN 1.08 Water Quality Device Oil Storage Volumes

Introduction

The information in this document is designed to provide values to general storage capacities (gallons) for oil and grease or free phase oil/petroleum product spills into ADS water quality devices. The information provided is not intended to be used for project design (i.e., maximum flow rates, etc.). Spill incidents that involve high velocities into these devices will yield different results/capacities. It is assumed that the spill flow rates will be less than 10% of the maximum treatment rate (MTR) into an individual ADS Water Quality device.

Oil and Grease (O&G) is a common term for measuring total petroleum hydrocarbons (TPH), lubricating oils, oil and oil byproducts found in stormwater runoff. It is assumed that the densities for these types of O&G pollutants are less than that of water (i.e., less than 1g/cm^3).

Spill Capacities

For applications located at sensitive maintenance, transportation, fueling operations, spill containment is a concern. Most of these sites have safety measures and alarms to alert the owner that a spill has occurred. ADS's BaySeparator, Barracuda[®], and Water Quality Unit (WQU), all have the capability to store spills that occur in non-storm events. Table 1 lists the spill containment volumes for each of our units.

Diagrams provided (Figures 1, 2, and 3) show how and where the spilled material is stored within a given ADS unit. It is the responsibility of the owner to remediate and extract the free phase oil shortly after the spill event has occurred and prior to subsequent storm event.

Table 1: Spill Capacities

Baracuda Unit	Spill Capacity, gallons (L)
S3	26 (98)
S4	51 (193)
S5	86 (325)
S6	115 (435)
S8	212 (802)
S10	305 (1154)

BaySeparator Unit	Spill Capacity, gallons (L) ¹
1/2K	226 (855)
1K	320 (1211)
3K	456 (1726)
5K	621 (2350)
10K	1567 (5931)

ADS WQU Unit	Spill Capacity, gallons (L)
3615	221 (836)
3620	225 (851)
3640	470 (1779)
4220	285 (1078)
4240	605 (2290)
4820	410 (1552)
4840	860 (3255)
6020	650 (2460)
6040	1380 (5223)

¹ BaySeparator with larger secondary manholes can store more gallons of oil. Contact ADS Engineering for information on larger storage systems for the BaySeparator.

Spill Capacity Details

For each ADS product, the spill oil will be stored in an accessible area of the device. For the Barracuda it will be contained in the inletting “bowl” area below the invert out of the system (See Figure 1). For the BaySeparator, the spill will be stored in the secondary manhole and stored between the invert into the secondary manhole and the top elevation invert out to the BaySeparator™ unit (See Figure 2). For the ADS Water Quality Unit the area will be storage between the elevations of sedimentation internal weir and the effluent exit “plate” opening to the final section of the WQU (See Figure 3).

Figure 1: Barracuda Oil Capacity Zone

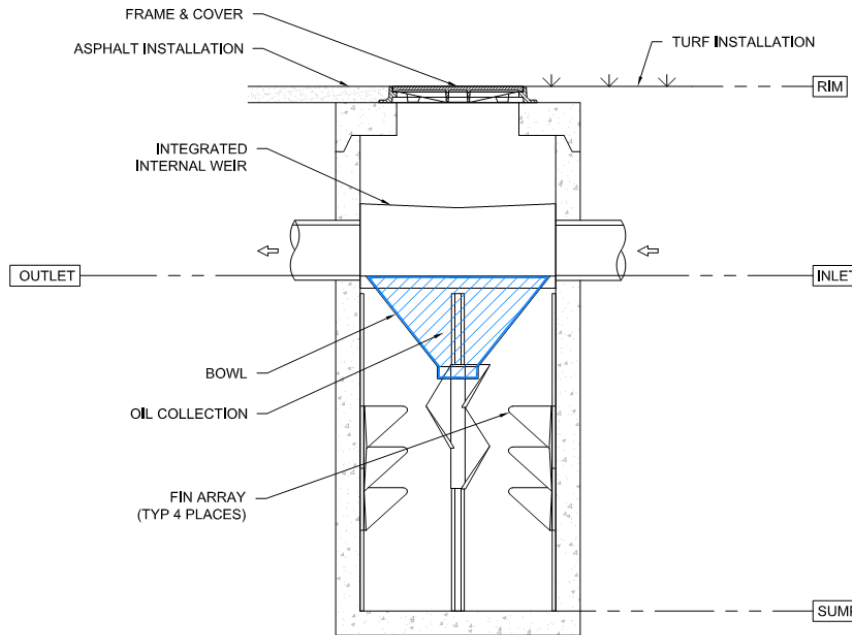

Figure 2: BaySeparator Oil Capacity Zone

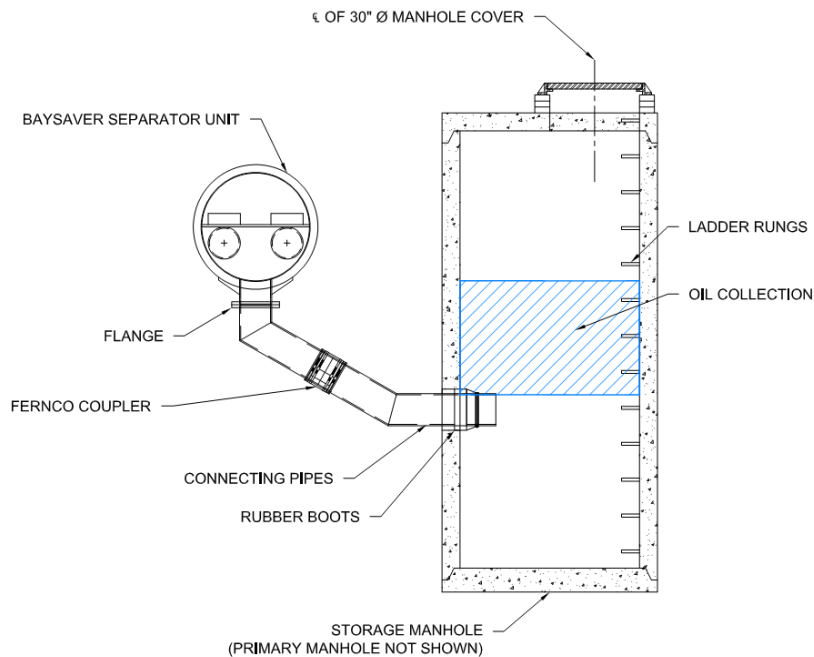
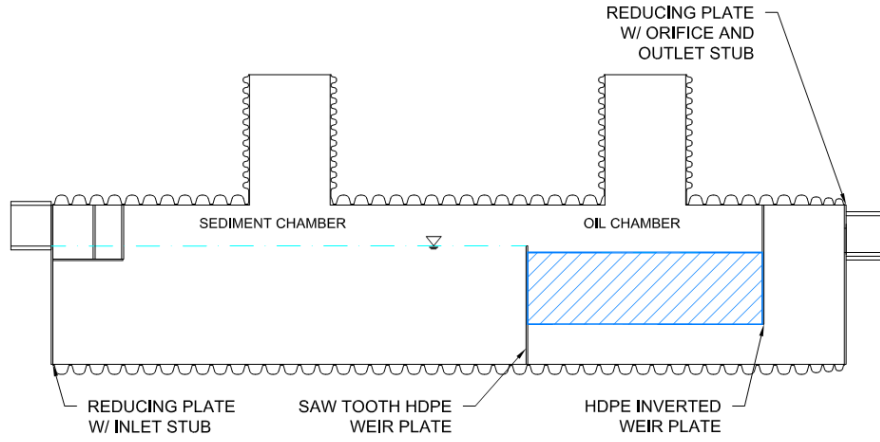

Figure 3: ADS WQU Oil Capacity Zone



Technical Note

TN 2.01 Minimum and Maximum Burial Depth for Corrugated HDPE Pipe (per AASHTO)

Introduction

The information in this document is designed to provide answers to general cover height questions; the data provided is not intended to be used for project design. The design procedure described in the Structures section (Section 2) of the Drainage Handbook provides detailed information for analyzing most common installation conditions. This procedure should be utilized for project specific designs.

The two common cover height concerns are minimum cover in areas exposed to vehicular traffic and maximum cover heights. Either may be considered "worst case" scenario from a loading perspective, depending on the project conditions.

The minimum and maximum cover heights in this technical note are not applicable to retention/detention systems, where unique configurations of fittings may require different minimum and maximum cover height limits. Please reference ADS Standard Detail 702 "Retention-Detention System (Cross-Section)" for cover height recommendations.

Minimum Cover in Traffic Applications

Pipe diameters from 4- through 48-inch (100-1200 mm) installed in traffic areas (AASHTO H-20, H-25, or HL-93 loads) must have at least one foot (0.3m) of cover over the pipe crown, while 54- and 60-inch (1350 and 1500 mm) pipes must have at least 24 inches (0.6m) of cover. The backfill envelope must be constructed in accordance with the Installation section (Section 5) of the Drainage Handbook and the requirements of ASTM D2321. The backfill envelope must be of the type and compaction listed in Appendix A-5, Table A-5-2 of the Drainage Handbook. In Table 1 below, this condition is represented by a Class III material compacted to 95% standard Proctor density or a Class II material compacted to 90% standard proctor density, although other material can provide similar strength at slightly lower levels of compaction. Structural backfill material should extend to the crown of the pipe; the remaining cover should be appropriate for the installation and as specified by the design engineer. If settlement or rutting is a concern, it may be appropriate to extend the structural backfill to grade. Where pavement is involved, sub-base material can be considered in the minimum burial depth. While rigid pavements can be included in the minimum cover, the thickness of flexible pavements should not be included in the minimum cover.

Additional information that may affect the cover requirements is included in the Installation section (Section 5) of the Drainage Handbook. Some examples of what may need to be considered are temporary heavy equipment, construction loading, paving equipment and similar loads that are less than the design load, the potential of pipe flotation, and the type of surface treatment which will be installed over the pipe zone.

Table 1
Minimum Cover Requirements for ADS N-12®, N-12 ST, and N-12 WT (per AASHTO) with AASHTO H-20, H-25, or HL-93 Load

Inside Diameter, ID, in.(mm)	Minimum Cover ft. (m)	Inside Diameter, ID, in.(mm)	Minimum Cover ft. (m)
4 (100)	1 (0.3)	24 (600)	1 (0.3)
6 (150)	1 (0.3)	30 (750)	1 (0.3)
8 (200)	1 (0.3)	36 (900)	1 (0.3)
10 (250)	1 (0.3)	42 (1050)	1 (0.3)
12 (300)	1 (0.3)	48 (1200)	1 (0.3)
15 (375)	1 (0.3)	54 (1350)	2 (0.6)
18 (450)	1 (0.3)	60 (1500)	2 (0.6)

Notes for Table 1:

1. *Minimum covers presented here were calculated assuming Class III backfill material to 95% standard Proctor density or Class II backfill material to 90% standard Proctor density around the pipe and structural backfill to the crown of the pipe, as recommended in Section 5 of the Drainage Handbook, with an additional layer of compacted traffic lane sub-base for a total cover as required. In shallow traffic installations, especially where pavement is involved, a good quality compacted material to grade is required to prevent surface rutting.*
2. *The minimum covers specified do not include pavement thickness. A pavement section of 0.4' is typical.*
3. *Backfill materials and compaction levels not shown in the table may also be acceptable. Contact ADS for further detail.*
4. *Calculations assume no hydrostatic pressure and native soils that are as strong as the specified minimum backfill recommendations.*

Maximum Cover

Wall thrust generally governs the maximum cover a pipe can withstand and conservative maximum cover heights will result when using the information presented in the *Structures* section (Section 2) of the Drainage Handbook.

The maximum burial depth is highly influenced by the type of backfill and level of compaction around the pipe. General maximum cover limits for ADS N-12, N-12 ST, N-12 WT pipe, (ASTM F2306 and AASTHO M252/M294 Type S pipes) are shown in Table 3 for a variety of backfill conditions.

Table 3 was developed assuming pipe is installed in accordance with ASTM D2321 and the *Installation* section (Section 5) of the Drainage Handbook. Additionally, the calculations assume zero hydrostatic load, incorporate the maximum safety factors represented in Structures section of the Drainage Handbook, use material properties consistent with the expected performance characteristics for N-12 (per ASTM F2306) materials as shown in Table 2 below, and assume the native soil is of adequate strength and is suitable for installation. For applications requiring fill heights greater than those shown in Table 3 or where hydrostatic pressure due to groundwater is present, contact an ADS engineering representative.

Figure 1
ADS N-12, N-12 ST, and N-12 WT (per AASHTO) Trench Detail Under Pavement

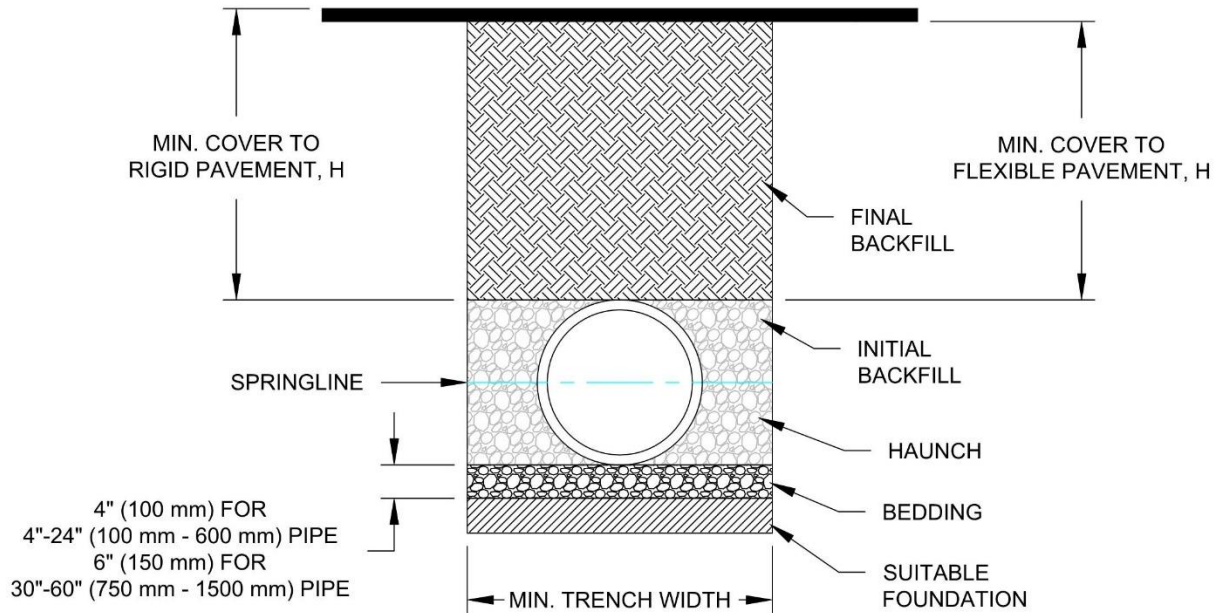

Table 2
ADS N-12 (per AASHTO) Mechanical Properties

Cell Class	Factored Compressive Strain (%)	Tension Strain (%)	Initial		75-Year	
			Fu (psi)	E (psi)	Fu (psi)	E (psi)
ASTM D3350 435400C	4.1	5.0	3,000	110,000	900	21,000

Table 3
Maximum Cover for ADS N-12, N-12 ST, and N-12 WT Pipe (per AASHTO), ft (m)

Diameter in. (mm)	Class 1		Class 2			Class 3	
	Compacted	Dumped	95%	90%	85% ³	95%	90% ³
4 (100)	37 (11.3)	18 (5.5)	25 (7.6)	18 (5.5)	12 (3.7)	18 (5.5)	13 (4.0)
6 (150)	44 (13.4)	20 (6.1)	29 (8.8)	20 (6.1)	14 (4.3)	21 (6.4)	15 (4.6)
8 (200)	32 (9.8)	15 (4.6)	22 (6.7)	15 (4.6)	10 (3.0)	16 (4.9)	11 (3.4)
10 (250)	38 (11.6)	18 (5.5)	26 (7.9)	18 (5.5)	12 (3.7)	18 (5.5)	13 (4.0)
12 (300)	35 (10.7)	17 (5.2)	24 (7.3)	17 (5.2)	8 (2.4)	17 (5.2)	11 (3.4)
15 (375)	38 (11.6)	17 (5.2)	25 (7.6)	17 (5.2)	8 (2.4)	18 (5.5)	11 (3.4)
18 (450)	36 (11.0)	17 (5.2)	24 (7.3)	17 (5.2)	8 (2.4)	17 (5.2)	11 (3.4)
24 (600)	28 (8.5)	13 (4.0)	20 (6.1)	13 (4.0)	7 (2.1)	14 (4.3)	10 (3.0)
30 (750)	28 (8.5)	13 (4.0)	20 (6.1)	13 (4.0)	7 (2.1)	14 (4.3)	9 (2.7)
36 (900)	26 (7.9)	12 (3.7)	18 (5.5)	12 (3.7)	7 (2.1)	13 (4.0)	9 (2.7)
42 (1050)	23 (7.0)	11 (3.4)	16 (4.9)	11 (3.4)	7 (2.1)	11 (3.4)	7 (2.1)
48 (1200)	25 (7.6)	11 (3.4)	17 (5.2)	11 (3.4)	7 (2.1)	12 (3.7)	7 (2.1)
54 (1350)	22 (6.7)	10 (3.0)	16 (4.9)	10 (3.0)	6 (1.8)	11 (3.4)	7 (2.1)
60 (1500)	25 (7.6)	11 (3.4)	17 (5.2)	11 (3.4)	6 (1.8)	12 (3.7)	7 (2.1)

Notes:

1. Results based on calculations shown in the Structures section of the ADS Drainage Handbook (v20.7). Calculations assume no hydrostatic pressure and a density of 120 pcf (1926 kg/m³) for overburden material.
2. Installation assumed to be in accordance with ASTM D2321 and the Installation section of the Drainage Handbook.
3. For installations using lower quality backfill materials or lower compaction efforts, pipe deflection may exceed the 5% design limit; however controlled deflection may not be a structurally limiting factor for the pipe. For installations where deflection is critical, pipe placement techniques or periodic deflection measurements may be required to ensure satisfactory pipe installation.
4. Backfill materials and compaction levels not shown in the table may also be acceptable. Contact ADS for further detail.
5. Material must be adequately “knifed” into haunch and in between corrugations. Compaction and backfill material is assumed uniform throughout entire backfill zone.
6. Compaction levels shown are for standard Proctor density.
7. For projects where cover exceeds the maximum values listed above, contact ADS for specific design considerations.
8. Calculations assume no hydrostatic pressure. Hydrostatic pressure will result in a reduction in allowable fill height. Reduction in allowable fill height must be assessed by the design engineer for the specific field conditions.
9. Fill height for dumped Class I material incorporate an additional degree of conservatism that is difficult to assess due to the large degree of variation in the consolidation of this material as it is dumped. There is limited analytical data on its performance. For this reason, values as shown are estimated to be conservatively equivalent to Class 2, 90% SPD.



Technical Note

TN 2.02 Minimum and Maximum Cover Heights for Corrugated HDPE Pipe (per ASTM F2648)

Introduction

The information in this document is designed to provide answers to general cover height questions; the data provided is not intended to be used for project design. The design procedure described in the *Structures* section (Section 2) of the Drainage Handbook provides detailed information for analyzing most common installation conditions. This procedure should be utilized for project specific designs.

The two common cover height concerns are minimum cover in areas exposed to vehicular traffic and maximum cover heights. Either may be considered “worst case” scenario from a loading perspective, depending on the project conditions.

Minimum Cover in Traffic Applications

Pipe diameters from 4- through 48-inch (100-1200 mm) installed in traffic areas (AASHTO H-25 or HS-25 loads) must have at least one foot (0.3m) of cover over the pipe crown, while 60-inch (1500 mm) pipe must have at least 24 inches (0.6m) of cover. The backfill envelope must be constructed in accordance with the *Installation* section (Section 5) of the Drainage Handbook and the requirements of ASTM D2321. The backfill envelope must be of the type and compaction listed in Appendix A-5, Table A-5-2A of the Drainage Handbook. In Table 1 below, this condition is represented by a Class II material compacted to 90% standard Proctor density, although other material can provide similar strength at slightly lower levels of compaction. Structural backfill material should extend to the crown of the pipe; the remaining cover should be appropriate for the installation and as specified by the design engineer. If settlement or rutting is a concern, it may be appropriate to extend the structural backfill to grade. Where pavement is involved, sub-base material can be considered in the minimum burial depth. While rigid pavements can be included in the minimum cover, the thickness of flexible pavements should not be included in the minimum cover.

Additional information that may affect the cover requirements is included in the *Installation* section (Section 5) of the Drainage Handbook. Some examples of what may need to be considered are temporary heavy equipment, construction loading, paving equipment and similar loads that are less than the design load, the potential of pipe flotation, and the type of surface treatment which will be installed over the pipe zone. Please note that Table 1 and 3 are based on the installation of N-12 and MEGA GREEN (per ASTM F2648) pipe under pavement using a uniform backfill type and compaction level, as depicted in Figure 1.

Table 1
Minimum Cover Requirements for N-12® and MEGAGREEN™ Pipes (per ASTM F2648)
with AASHTO H-25 or HS-25 Load

Inside Diameter, ID, inches (mm)	Minimum Cover feet (m)
4 (100) – 48 (1200)	1 (0.3)
60 (1500)	2 (0.6)

Note: Minimum covers presented here were calculated assuming Class II backfill material compacted to 90% standard Proctor density around the pipe and structural backfill to the crown of the pipe, as recommended in Section 5 of the Drainage Handbook, with an additional layer of compacted traffic lane sub-base for a total cover as required. In shallow traffic installations, especially where pavement is involved, a good quality compacted material to grade is required to prevent surface settlement and rutting.

Maximum Cover

Wall thrust generally governs the maximum cover a pipe can withstand and conservative maximum cover heights will result when using the information presented in the Structures section (Section 2) of the Drainage Handbook.

The maximum burial depth is highly influenced by the type of backfill and level of compaction around the pipe. General maximum cover limits for N-12 and MEGA GREEN (per ASTM F2648) pipe are shown in Table 3 for a variety of backfill conditions.

Table 3 was developed assuming pipe is installed in accordance with ASTM D2321 and the Installation section (Section 5) of the Drainage Handbook. Additionally, the calculations assume no hydrostatic load around the pipe, incorporate the maximum safety factors represented in Structures section of the Drainage Handbook, use material properties consistent with the expected performance characteristics for N-12 and MEGA GREEN (per ASTM F2648) materials as shown in Table 2 below, and assume the native soil (in-situ) is of adequate strength and is suitable for installation. For applications requiring fill heights greater than those shown in Table 3 or where hydrostatic pressure due to groundwater is present, contact an ADS engineering representative.

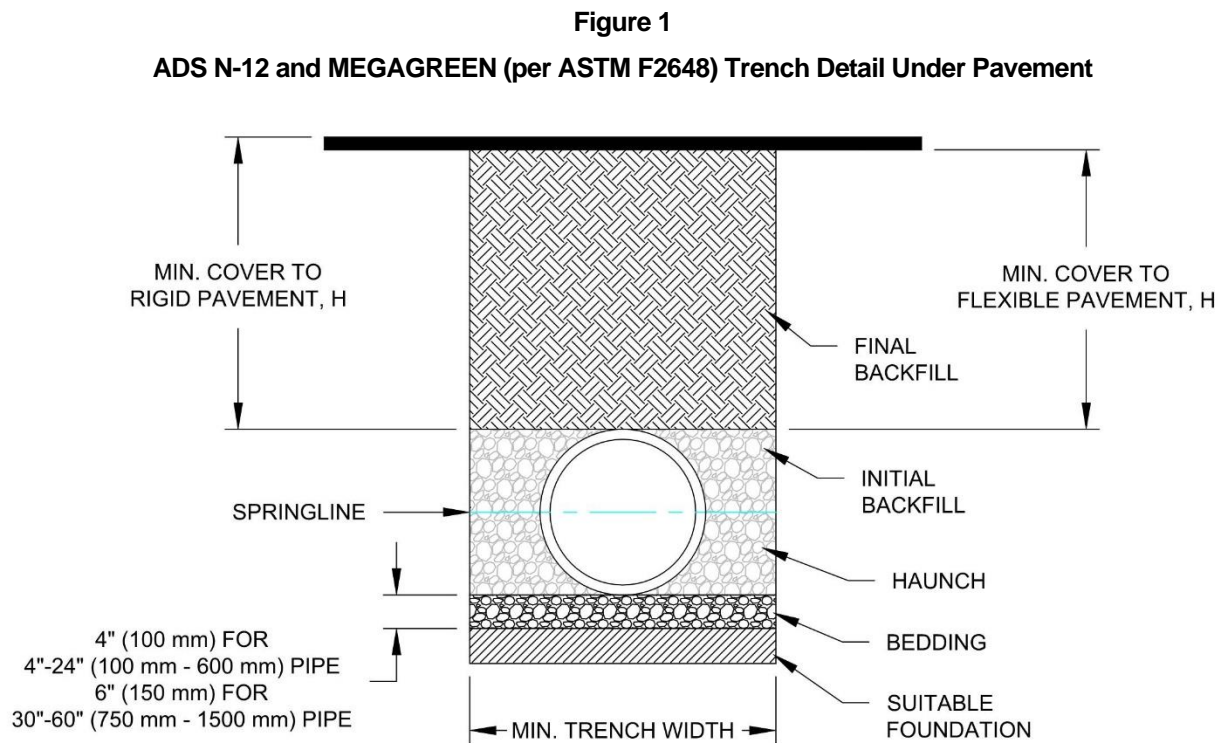

Table 2
ADS N-12 and MEGAGREEN (per ASTM F2648) Mechanical Properties

Cell Class	Design Compressive Strain (%)	Design Tensile Strain (%)	Initial		50-Year	
			Fu (psi)	E (psi)	Fu (psi)	E (psi)
ASTM D3350 424420C – 4-10" 435420C – 12-60"	3.7	4.0	3,000	110,000	800	21,000

Table 3
Maximum Cover for ADS N-12 and MEGAGREEN Pipes (per ASTM F2648), ft (m)

Diameter in. (mm)	Class 1				Class 2				Class 3	
	Compacted		Dumped		95%		90%		95%	
4 (100)	34	(10.4)	16	(4.9)	23	(7.0)	16	(4.9)	17	(5.2)
6 (150)	40	(12.2)	19	(5.8)	27	(8.2)	19	(5.8)	20	(6.1)
8 (200)	30	(9.1)	14	(4.3)	21	(6.4)	14	(4.3)	15	(4.6)
10 (250)	34	(10.4)	16	(4.9)	23	(7.0)	16	(4.9)	17	(5.2)
12 (300)	35	(10.7)	17	(5.2)	24	(7.3)	17	(5.2)	18	(5.5)
15 (375)	37	(11.3)	18	(5.5)	25	(7.6)	18	(5.5)	19	(5.8)
18 (450)	32	(9.8)	15	(4.6)	22	(6.7)	15	(4.6)	16	(4.9)
24 (600)	27	(8.2)	13	(4.0)	19	(5.8)	13	(4.0)	14	(4.3)
30 (750)	22	(6.7)	11	(3.4)	16	(4.9)	11	(3.4)	11	(3.4)
36 (900)	26	(7.9)	12	(3.7)	18	(5.5)	12	(3.7)	13	(4.0)
42 (1050)	24	(7.3)	11	(3.4)	17	(5.2)	11	(3.4)	12	(3.7)
48 (1200)	23	(7.0)	11	(3.4)	16	(4.9)	11	(3.4)	12	(3.7)
60 (1500)	26	(7.9)	12	(3.7)	18	(5.5)	12	(3.7)	13	(4.0)

Notes:

1. Results based on calculations shown in the Structures section of the ADS Drainage Handbook(v20.6). Calculations assume no hydrostatic pressure and a density of 120 pcf (1926 kg/m³) for overburden material.
2. Installation assumed to be in accordance with ASTM D2321 and the Installation section of the Drainage Handbook.
3. Material must be adequately “knifed” into haunch and in between corrugations. Compaction and backfill material is assumed uniform throughout entire backfill zone.
4. Compaction levels shown are for standard Proctor density.
5. Installations of pipe manufactured per ASTM F2648 are only applicable to the fill heights, type of embedment materials and compaction levels listed above.
6. For projects where cover exceeds the maximum values listed above, contact ADS for specific design considerations.
7. Calculations assume no hydrostatic pressure. Hydrostatic pressure will result in a reduction in allowable fill height. Reduction in allowable fill height must be assessed by the design engineer for the specific field conditions.



Technical Note

TN 2.03 Minimum and Maximum Cover Heights for Single Wall Corrugated HDPE Pipe

Introduction

The information in this document is designed to provide answers to general cover height questions; the data provided is not intended to be used for project design. The design procedure described in the *Structures* section (Section 2) of the Drainage Handbook provides detailed information for analyzing most common installation conditions. This procedure should be utilized for project specific designs.

The two common cover height concerns are minimum cover in areas exposed to vehicular traffic and maximum cover heights. Either may be considered "worst case" scenario from a loading perspective, depending on the project conditions.

Minimum Cover in Traffic Applications

Pipe diameters from 3- through 24-inch (75-600 mm) installed in traffic areas (AASHTO H-25 or HS-25 loads) must have at least one foot (0.3m) of cover over the pipe crown. The backfill envelope must be constructed in accordance with the *Installation* section (Section 5) of the Drainage Handbook and the requirements of ASTM D2321. The backfill envelope must be of the type and compaction listed in Table 2-3 of the Drainage Handbook. In Table 1 below, this condition is represented by a Class III material compacted to 90% standard Proctor density, although other material can provide similar strength at slightly lower levels of compaction. Structural backfill material should extend to the crown of the pipe; the remaining cover should be appropriate for the installation and as specified by the design engineer. If settlement or rutting is a concern, it may be appropriate to extend the structural backfill to grade. Where pavement is involved, sub-base material can be considered in the minimum burial depth. While rigid pavements can be included in the minimum cover, the thickness of flexible pavements should not be included in the minimum cover.

Additional information that may affect the cover requirements is included in the *Installation* section (Section 5) of the Drainage Handbook. Some examples of what may need to be considered are temporary heavy equipment, construction loading, paving equipment and similar loads that are less than the design load, the potential of pipe flotation, and the type of surface treatment which will be installed over the pipe zone.

Table 1
Minimum Cover Requirements for ADS Single Wall Highway and Heavy Duty Pipe with AASHTO H-25 or HS-25 Load

Inside Diameter, ID, in.(mm)	Minimum Cover ft. (m)	Inside Diameter, ID, in.(mm)	Minimum Cover ft. (m)
3 (75)	1 (0.3)	24 (600)	1 (0.3)
4 (100)	1 (0.3)	12 (300)	1 (0.3)
6 (150)	1 (0.3)	15 (375)	1 (0.3)
8 (200)	1 (0.3)	18 (450)	1 (0.3)
10 (250)	1 (0.3)		

Note: Minimum covers presented here were calculated assuming Class III backfill material compacted to 90% standard Proctor density around the pipe and structural backfill to the crown of the pipe, as recommended in Section 5 of the Drainage Handbook, with an additional layer of compacted traffic lane sub-base for a total cover as required. In shallow traffic installations, especially where pavement is involved, a good quality compacted material to grade is required to prevent surface settlement and rutting.

Maximum Cover

Wall thrust generally governs the maximum cover a pipe can withstand and conservative maximum cover heights will result when using the information presented in the Structures section (Section 2) of the Drainage Handbook.

The maximum burial depth is highly influenced by the type of backfill and level of compaction around the pipe. General maximum cover limits for ADS Single Wall Highway and Heavy Duty pipes are shown in Table 2 for a variety of backfill conditions.

Table 2 was developed assuming pipe is installed in accordance with ASTM D2321 and the Installation section (Section 5) of the Drainage Handbook. Additionally, the calculations; assume zero hydrostatic load, incorporate the maximum safety factors represented in structures section of the Drainage Handbook, and assume the native soil is of adequate strength and is suitable for installation. For applications requiring fill heights greater than those shown in Table 2, contact the ADS Regional Engineering or Application Engineering departments.

Table 2
Maximum Cover for ADS Single Wall Heavy Duty and Highway Pipe, ft (m)

Diameter in (mm)	Class 1		Class 2			Class 3		
	Compacted	Dumped	95%	90%	85%	95%	90%	85%
4 (100)	41	13	27	18	13	19	13	11
6 (150)	(12.5)	(4.0)	(8.2)	(5.5)	(4.0)	(5.8)	(4.0)	(3.9)
8 (200)								
10 (250)								
12 (300)	38	12	25	17	12	18	12	10
15 (375)	(11.6)	(3.7)	(7.6)	(5.2)	(3.7)	(5.5)	(3.7)	(3.0)
18 (450)								
24 (600)	32	11	21	15	11	16	11	9
	(9.8)	(3.4)	(6.4)	(4.6)	(3.4)	(4.9)	(3.4)	(2.7)

Notes:

1. Results based on calculations shown in the Structures section of the ADS Drainage Handbook. Calculations assume no hydrostatic pressure and a density of 120 pcf (1926 kg/m³) for overburden material.
2. Installation assumed to be in accordance with ASTM D2321 and the Installation section of the Drainage Handbook.
3. Backfill materials and compaction levels not shown in the table may also be acceptable. Contact ADS for further detail.
4. Material must be adequately "knifed" into haunch and in between corrugations. Compaction and backfill material is assumed uniform throughout entire backfill zone.
5. Compaction levels shown are for standard Proctor density.
6. For projects where cover exceeds the maximum values listed above, contact ADS for specific design considerations.
7. Calculations assume no hydrostatic pressure. Hydrostatic pressure will result in a reduction in allowable fill height. Reduction in allowable fill height must be assessed by the design engineer for the specific field conditions.
8. Fill height for dumped Class I material incorporate an additional degree of conservatism that is difficult to assess due to the large degree of variation in the consolidation of this material as it is dumped. There is limited analytical data on its performance. For this reason, values as shown are estimated to be conservatively equivalent to Class 2, 85% SPD.



Technical Note

TN 2.04 Minimum and Maximum Cover Heights for HP Storm Pipe for Storm Drainage

Introduction

The information in this document is designed to provide answers to general cover height questions; the data provided is not intended to be used for project design. The design procedure described in the *Structures* section (Section 2) of the Drainage Handbook provides detailed information for analyzing most common installation conditions. This procedure should be utilized for project specific designs.

The two common cover height concerns are minimum cover in areas exposed to vehicular traffic and maximum cover heights. Either may be considered "worst case" scenario from a loading perspective, depending on the project conditions.

Minimum Cover in Traffic Applications

Pipe diameters from 12- through 48-inch (300-1200 mm) installed in traffic areas (AASHTO H-20, H-25, or HL-93 loads) must have at least one foot (0.3m) of cover over the pipe crown, while 60-inch (1500 mm) pipes must have at least 24 inches (0.6m) of cover. The backfill envelope must be constructed in accordance with the *Installation* section (Section 5) of the Drainage Handbook and the requirements of ASTM D2321. The backfill envelope must be of the type and compaction listed in Appendix A-5, Table A-5-2 of the Drainage Handbook. In Table 1 below, this condition is represented by a Class III material compacted to 95% standard Proctor density or a Class II material compacted to 90% standard proctor density, although other material can provide similar strength at slightly lower levels of compaction. Structural backfill material should extend to the crown of the pipe; the remaining cover should be appropriate for the installation and as specified by the design engineer. If settlement or rutting is a concern, it may be appropriate to extend the structural backfill to grade. Where pavement is involved, sub-base material can be considered in the minimum burial depth. While rigid pavements can be included in the minimum cover, the thickness of flexible pavements should not be included in the minimum cover.

Additional information that may affect the cover requirements is included in the *Installation* section (Section 5) of the Drainage Handbook. Some examples of what may need to be considered are temporary heavy equipment, construction loading, paving equipment and similar loads that are less than the design load, the potential of pipe flotation, and the type of surface treatment which will be installed over the pipe zone.

Table 1
Minimum Cover Requirements for ADS HP Storm with AASHTO H-25, H-20, or HL-93 Load

Inside Diameter, ID, in.(mm)	Minimum Cover ft. (m)	Inside Diameter, ID, in.(mm)	Minimum Cover ft. (m)
12 (300)	1 (0.3)	36 (900)	1 (0.3)
15 (375)	1 (0.3)	42 (1050)	1 (0.3)
18 (450)	1 (0.3)	48 (1200)	1 (0.3)
24 (600)	1 (0.3)	60 (1500)	2 (0.6)

Notes:

1. Minimum covers presented here were calculated assuming Class III backfill material compacted to 95% standard Proctor density or Class II backfill material compacted to 90% standard Proctor density around the pipe, as recommended in Section 5 of the Drainage Handbook, with an additional layer of compacted traffic lane sub-base for a total cover as required. In shallow traffic installations, especially where pavement is involved, a good quality compacted material to grade is required to prevent surface settlement and rutting.
2. The minimum covers specified do not include pavement thickness. A pavement section of 0.4' is typical.
3. Backfill materials and compaction levels not shown in the table may also be acceptable. Contact ADS for further detail.
4. Calculations assume no hydrostatic pressure and native soils that are as strong as the specified minimum backfill recommendations.

Maximum Cover

Wall thrust generally governs the maximum cover a pipe can withstand and conservative maximum cover heights will result when using the information presented in the *Structures* section (Section 2) of the Drainage Handbook. Table 2 below shows the material properties consistent with the expected performance characteristics for HP Storm materials for a 100-year design life.

The maximum burial depth is highly influenced by the type of backfill and level of compaction around the pipe. General maximum cover limits for ADS HP Storm use in storm drainage applications are shown in Tables 3 for a variety of backfill conditions.

Table 3 was developed assuming pipe is installed in accordance with ASTM D2321 and the *Installation* section (Section 5) of the Drainage handbook. Additionally, the calculations assume no hydrostatic load around the pipe, incorporate the maximum conservative AASHTO LRFD design factors represented in *Structures* section of the Drainage Handbook, use material properties consistent with the expected performance characteristics for HP Storm materials, as shown in Table 2, and assume the native (in-situ) soil is of adequate strength and suitable for installation. For applications requiring fill heights greater than those shown in Table 3 or where hydrostatic pressure due to groundwater is expected, contact an ADS Engineer.

**Table 2
ADS HP Storm Mechanical Properties**

Resin	ASTM Specification	Allowable Long Term Strain %	Initial		75-Year	
			Fu (psi)	E (psi)	Fu (psi)	E (psi)
Polypropylene, Impact-modified copolymer	ASTM F2881	3.7	3,500	175,000	1,000	28,000

**Figure 1
ADS HP Storm Pipe Trench Detail with Uniform Backfill
(Traffic and Non-Traffic Applications)**

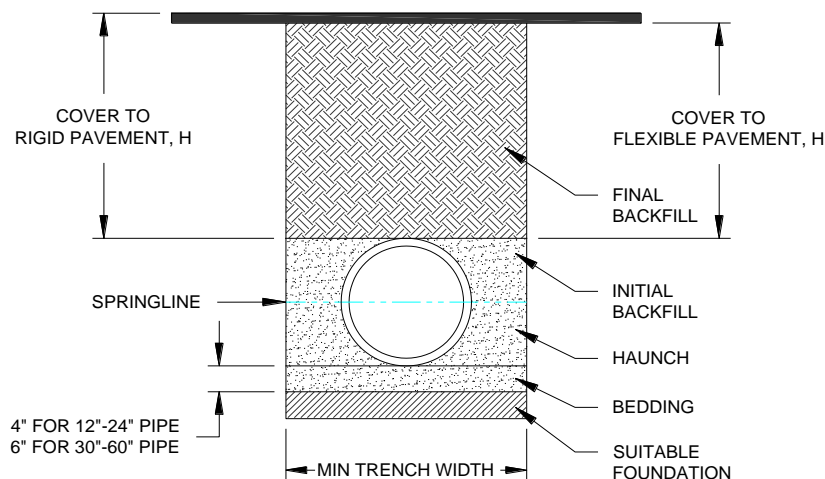

Table 3
Maximum Cover for ADS HP Storm Pipe with Uniform Backfill, ft (m)

Diameter	Class 1		Class 2			Class 3		Class 4
	Compacted	Dumped	95%	90%	85% ³	95%	90% ³	95% ³
12 (300)	41 (12.5)	21 (6.4)	28 (8.5)	21 (6.4)	16 (4.9)	20 (6.1)	16 (4.9)	16 (4.9)
15 (375)	42 (12.8)	21 (6.4)	29 (8.8)	21 (6.4)	16 (4.9)	21 (6.4)	16 (4.9)	16 (4.9)
18 (450)	44 (13.4)	21 (6.4)	30 (9.1)	21 (6.4)	16 (4.9)	22 (6.7)	17 (5.2)	16 (4.9)
24 (600)	30 (9.1)	15 (4.6)	21 (6.4)	15 (4.6)	11 (3.4)	16 (4.9)	11 (3.4)	11 (3.4)
30 (750)	39 (11.9)	19 (5.8)	27 (8.2)	19 (5.8)	14 (4.3)	19 (5.8)	15 (4.6)	14 (4.3)
36 (900)	28 (8.5)	14 (4.3)	20 (6.1)	14 (4.3)	10 (3.0)	14 (4.3)	11 (3.4)	10 (3.0)
42 (1050)	30 (9.1)	14 (4.3)	21 (6.4)	14 (4.3)	10 (3.0)	15 (4.6)	11 (3.4)	10 (3.0)
48 (1200)	29 (8.8)	14 (4.3)	20 (6.1)	14 (4.3)	9 (2.7)	14 (4.3)	10 (3.0)	10 (3.0)
60 (1500)	29 (8.8)	14 (4.3)	20 (6.1)	14 (4.3)	9 (2.7)	14 (4.3)	10 (3.0)	9 (2.7)

Notes:

1. Results based on calculations shown in the Structures section of the ADS Drainage Handbook (v20.7). Calculations assume no hydrostatic pressure and a density of 120 pcf (1926 kg/m³) for overburden material.
2. Installation assumed to be in accordance with ASTM D2321 and the Installation section of the Drainage Handbook.
3. For installations using lower quality backfill materials or lower compaction efforts, pipe deflection may exceed the 5% design limit; however controlled deflection may not be a structurally limiting factor for the pipe. For installation where deflection is critical, pipe placement techniques or periodic deflection measurements may be required to ensure satisfactory pipe installation.
4. Backfill materials and compaction levels not shown in the table may also be acceptable. Contact ADS for further detail.
5. Material must be adequately “knifed” into haunch and in between corrugations. Compaction and backfill material is assumed uniform throughout entire backfill zone.
6. Compaction levels shown are for standard Proctor density.
7. For projects where cover exceeds the maximum values listed above, contact ADS for specific design considerations.
8. See ADS Standard Detail STD-101D for additional details.



Technical Note

TN 2.04A Minimum and Maximum Cover Heights for Alternate HP Storm Pipe Trench

Introduction

The information in this document is designed to provide answers regarding general cover heights questions regarding the alternative trench installation of ADS HP Storm pipe; the data provided is based on Culvert Analysis and Design (CANDE) with information presented in the *Structures* section (Section 2) of the Drainage Handbook and is not intended to be used for project design. Project specific properties should be included in analysis for specific project design.

Minimum Cover

Minimum cover for non-traffic rated applications (grass or landscape areas) is 12" (300mm) from top of pipe to ground surface, for all pipe diameters. Additional cover may be required to prevent flotation.

Maximum Cover

The maximum burial depth is highly influenced by the type of backfill and level of compaction around the pipe. General maximum cover limits for ADS HP Storm utilized in non-traffic rated storm drainage applications; using different backfill materials (split backfill) in the backfill zone, as depicted in Figure 1, are shown in Table 2.

Table 2 was developed using CANDE modeling software. CANDE is a finite element analysis tool developed by Dr. Mike Katona under the sponsorship of the FHWA and AASHTO and is available for download. The AASHTO LRFD design method is not able to evaluate complex scenarios, such as changing backfill material. AASHTO LRFD load and resistance factors, shown in the *Structures* section of the Drainage Handbook, are utilized in the CANDE analysis. Additionally, the CANDE analysis assumes no hydrostatic load around the pipe, uses material properties consistent with the expected performance characteristics for HP Storm materials, as shown in Table 1 below, and assumes the native (in-situ) soil is of adequate strength and suitable for installation. For applications requiring fill heights greater than those shown in Table 2, contact an ADS Engineer.

It should be noted that while an installation condition as depicted in Figure 1 can be modeled in CANDE and other structural evaluation software, there are constructability and practical installation considerations that should be taken into account when a designer is determining the best backfill plan for a project.

1. Changing material types at the springline of the pipe requires accounting for the different soil confining strengths of the two materials. This variation in soil strengths can result in a reduced cover height when compared to an installation where a single material type is used for the entire pipe embedment. Where materials of differing strengths are used in the pipe embedment, susceptibility to pipe deflection can increase if the materials are not properly placed and compacted.
2. The fill heights shown in Table 2 are based upon a minimum compaction density of 85% being achieved for the native material above the pipe springline. When considering moisture content and compaction effort, adequate compaction of Class 3 and 4 materials can be more difficult to achieve compared to the effort of a Class 1 material used in the haunch zone of the pipe.
3. When materials of different gradation are placed adjacent to each other, filter fabric separation or properly graded material, under the guidance of a geotechnical engineer, is recommended in order to prevent the migration of fines into the open-graded material.

These considerations are not intended to explicitly allow or discourage the use of native materials above the pipe springline, but simply to state that such embedment can be successful when implemented correctly. While ADS supports that the product can perform well within these installation parameters, overall successful execution is dependent not only on the product, but on coordination, input and agreement between the owner, engineer and contractor, based on each party's needs.

Table 1
ADS HP Storm Mechanical Properties

Resin	ASTM Specification	Allowable Long Term Strain %	Initial		100-Year	
			Fu (psi)	E (psi)	Fu (psi)	E (psi)
Polypropylene, Impact-modified copolymer	ASTM F2881	3.7	3,500	175,000	1,000	27,000

Figure 1
ADS HP Storm Pipe Split Backfill Trench Detail
(Non-Traffic Applications)

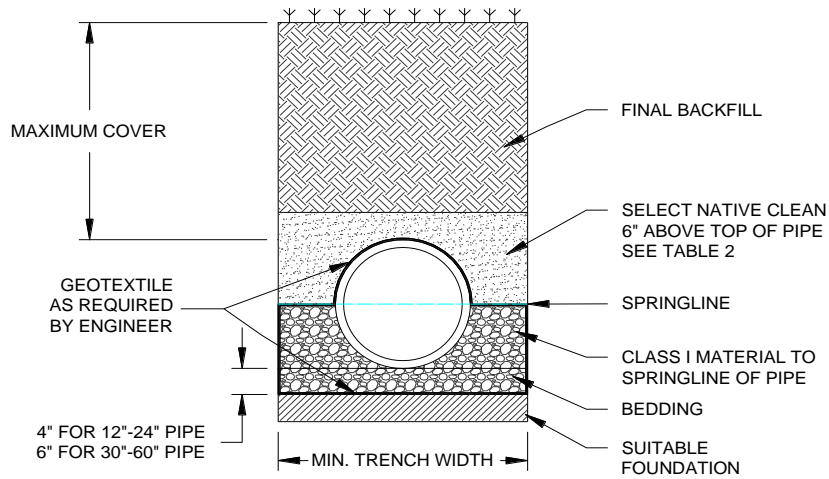

Table 2
Maximum Cover for ADS HP Storm Pipe with Split Backfill, ft (m)

Diameter in (mm)	Class 2	Class 3	Class 4
12 (300)	17 (5.2)	14 (4.3)	11 (3.4)
15 (375)	17 (5.2)	14 (4.3)	10 (3.0)
18 (450)	16 (4.9)	13 (4.0)	10 (3.0)
24 (600)	14 (4.3)	12 (3.7)	9 (2.7)
30 (750)	13 (4.0)	12 (3.7)	8 (2.4)
36 (900)	11 (3.4)	11 (3.4)	7 (2.1)
42 (1050)	11 (3.4)	11 (3.4)	7 (2.1)
48 (1200)	11 (3.4)	10 (3.0)	6 (1.8)
60 (1500)	11 (3.4)	10 (3.0)	6 (1.8)

Notes:

1. *Results based CANDE analysis. Calculations assume no hydrostatic pressure and a soil density of 120 pcf (1926 kg/m³) for overburden material.*
2. *Backfill materials and compaction levels not shown in the table may also be acceptable. Contact ADS for further detail.*
3. *Class 1 material used below springline must be adequately “knifed” into haunch and in between corrugations. Unless otherwise noted by the engineer class I material must be compacted in 6-inch (200mm) lifts.*
4. *Select native clean backfill shall be well placed, moderately compacted (85% SPD) Class IV or better per ASTM D2321 with no foreign debris including rocks, large clumps of organic or frozen material.*
5. *For projects where cover exceeds the maximum values listed above, contact ADS for specific design considerations.*



Technical Note

TN 3.02 AdvanEDGE® Hydraulic Performance

This technical note provides the inlet flow and core flow capacities of AdvanEDGE to be used in determining sizing and spacing of a subsurface drainage system.

Inlet Flow Capacity

The inlet flow of an AdvanEDGE panel is dependent upon perforation sizing and whether or not a geotextile is wrapped around the panel. Typically, the inlet flow of the panel is greater than the subbase material and is not a limiting factor in the design. However, inlet flow capacity for AdvanEDGE, with and without a geotextile, is provide in Table 1 for reference.

Table 1
AdvanEDGE Inlet Flow Capacity

Product	Inlet Flow Capacity, GPM/Sq. Ft
AdvanEDGE ¹	57
AdvanEDGE wrapped in geotextile ²	56

¹ Inlet capacity from Ohio DOT report on Hydraulic Design and Performance of edge drains.

² Geotextile flow value (Flux) based on geotextile with permittivity of 0.7 sec⁻¹.

Core Flow Capacity

ASTM D4716, Standard Test Method for Determining the (In-Plane) Flow Rate per Unit Width and Hydraulic Transmissivity for a Geosynthetic Using a Constant Head, was the original procedure for determining the flow capacity of AdvanEDGE. However, this procedure only addresses the panel installed in a horizontal plane, while the majority of applications install AdvanEDGE vertically. The Kentucky Transportation Center devised a flow test that determines flow rates in the vertical plane. The procedure has been accepted as an appropriate measurement of flow capacity and is included in ASTM D7001 Geocomposite for Pavement Edge Drains and Other Flow Applications.

Figure 1
AdvanEDGE Core Flow Capacity Horizontal Plane Installation

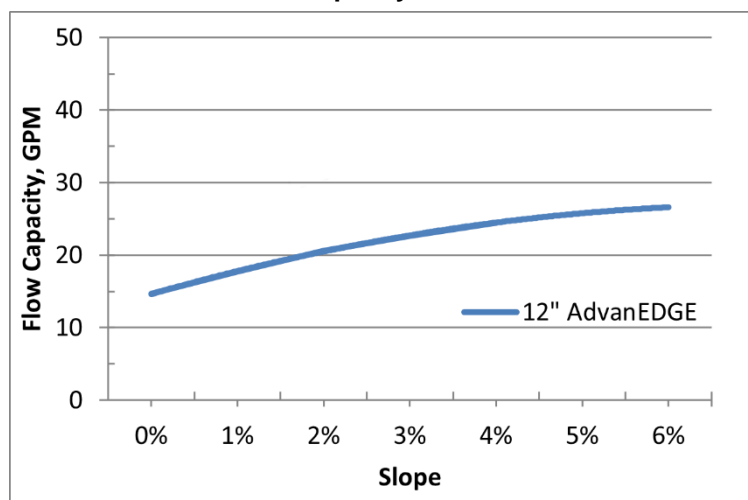

Note: Testing performed in accordance with ASTM D4716, with panel in horizontal plane and loaded at 10psi. Values reported in the Ohio DOT report on Hydraulic Design and Performance of edge drains.

Table 2
AdvanEDGE Core Flow Capacity, Vertical Plane Installation

Loading, psi	Flowrate, GPM
0	40
22	40

Note: Testing performed per the University of Kentucky In-Plane Flow Test. Values reported in Kentucky Transportation Center Research Report KTC-97-5



Technical Note

TN 4.01 Chemical Resistance of Polyethylene and Elastomers

The results reported herein are of testing performed on HDPE material, compiled from multiple sources. A listing of sources is available at the conclusion of this document. Actual results may vary on the environmental conditions for each particular application. In evaluating the capability of polyethylene pipe, fittings, and manholes to withstand chemical attack, consideration should be given to the following:

1. The effect of an active substance on polyethylene is not as severe when contact is intermittent.
2. Increasing temperature increases chemical activity.
3. Internal pressure may affect the rate of penetration of a substance.
4. Excessive bending and other stresses resulting from improper installation may affect the life of polyethylene products.
An example would be circumferential deflection beyond 50% or placing pipe directly on a large, sharp rock.

This listing contains accurate and reliable information to the best of our knowledge. The data contained herein is a compilation of studies conducted by various sources which Advanced Drainage Systems believes to be reliable.

However, the information cannot be guaranteed because the conditions of use are beyond our control. The user of this information assumes all risk associated with its use.

Polyethylene

Test Procedure

Polyethylene specimens were placed in the relevant substance for a period of time without the application of mechanical stress. They were then tested for swelling or weight loss and subjected to tensile testing. In critical applications, it is suggested that greater reliance be placed on actual field experience or testing should be performed under similar conditions of stress, exposure, temperature and duration which can be related to the anticipated application. Data regarding resistance to chemicals not listed may be available by contacting an ADS representative.

Symbols used in the following table:	
Symbol	Description
+	specimen is resistant swelling < 3% or alternatively weight loss < 0.5%, elongation of break not significantly changed
/	specimen has limited swelling 3 - 8% or alternatively weight resistance only loss 0.5 - 5%, and/or elongation at break decreased by < 50%
-	specimen is not resistant swelling > 8% or alternatively weight loss > 5%, and/or elongation a break decreased by > 50%
D	discoloration
*	or at the boil

Substance	POLYETHYLENE		
	Concentration	68°F	140°F
Acetaldehyde + acetic acid	90:10:00	+	
Acetaldehyde, aqueous	all	+	/
Acetamide		+	+
Acetic acid	100%	+	/ D
Acetic acid, aqueous	70%	+	+
Acetic acid ethyl ester		+	+
Acetic anhydride		+	/ D
Acetoacetic acid		+	
Acetone		+	+ *
Acetophenone		+	
Acetylene		+	
Acids, aromatic		+	+
Acronal dispersions		+	/
Acrylic acid emulsions		+	+
Acrylonitrile		+	+
Adipic acid, aqueous	saturated	+	+
Adipic acid ester		+	/
Aktivin (chioramine, aqueous, 1%)		+	+
Alcohol		+	
Alcoholic beverages		+	
Allyl acetate		+	+ to /
Allyl alcohol	96%	+	+
Allyl chloride		/	-
Alum, aqueous	all	+	+
Aluminum chloride, aqueous	all	+	+
Aluminum chloride, solid		+	+
Aluminum fluoride		+	+
Aluminum hydroxide		+	+
Aluminum metaphosphate		+	+
Aluminum sulphate, aqueous	saturated	+	+
Aluminum sulphate, solid		+	+
Amino acids		+	+
Ammonia, gaseous	100%	+	+
Ammonia, liquid		+	
Ammonia solution		+	+
Ammonium acetate, aqueous	All	+	+
Ammonium carbonate	All	+	+
Ammonium chloride, aqueous	All	+	+
Ammonium hydrosulphide, aqueous	All	+	+
Ammonium metaphosphate		+	+
Ammonium nitrate, aqueous	All	+	+
Ammonium phosphate, aqueous	All	+	+
Ammonium sulphate, aqueous	All	+	+
Ammonium sulphide, aqueous	All	+	+
Ammonium thiocyanate		+	+
Amyl acetate		+	+
Amyl alcohol		+	+
Amyl chloride	100%	/	-
Amyl phthalate		+	/
Aniline, aqueous	All	+	+
Aniline hydrochloride, aqueous	All	+	+
Animal oils		+	/
Aniseed oil		/	-
Anisole		/	/ to -
Anone (cyclohexanone)		+	/
Antifreeze agents (vehicles)		+	+
Aqua regia		-	
Anthraquinone sulphonic acid, aqueous (susp.)		+	+
Antimony chloride, anhydrous		+	+
Antimony pentachloride		+	+
Antimony trichloride		+	+
Arsenic acid anhydride		+	+
Arsenic acid, aqueous	all	+	+
Ascorbic acid		+	+
Asphalt		+	/
Aspirin		+	
Barium hydroxide, aqueous	all	+	+
Barium salts, aqueous	all	+	+
Battery acid		+	+
Beater glue		+	+
Beef fat		+	+ to /
Beer		+	
Beer coloring agent		+	+
Beeswax		+	/ to -
Benzaldehyde, aqueous	all	+	+ to /
Benzaldehyde in isopropyl alcohol	1%	+	+
Benzene	technically pure	/	/
Benzenesulphonic acid		+	+

Substance	POLYETHYLENE		
	Concentration	68°F	140°F
Benzoic acid, aqueous	all	+	+
Benzoyl chloride		/	/
Benzyl alcohol		+	+
Benzyl chloride		/	-
Bichromate-sulphuric acid		-	-
Bismuth salts		+	+
Bisulphate solution		+	+
Bitumen		+	/
Bleaching liquor containing 12.5% active chlorine		/	-
Bleaching powder (chloride of lime)		+	+
Bone oil		+	+
Borax, aqueous	all	+	+
Boric acid, aqueous	all	+	+
Boric acid methyl ester		+	/ to -
Boron trifluoride		+	+ to /
Brake fluid		+	+
Brandy-wine		+	
Brine (saturated)	saturated	+	+
Bromic acid		-	
Bromine fumes		-	
Bromine, liquid	100%	-	
Bromine water	cold saturated	+	
Bromochloromethane		-	
Butanediol, aqueous	all	+	+
Butane, gaseous		+	
Butanetriol, aqueous	all	+	+
Butanol, aqueous	all	+	+
Butanone		+	/ to -
Butoxyl (methoxybutyl acetate)		+	/
Butter		+	
Butyl acetate	technically pure	+	/
n-Butyl acetate		+	/
Butyl alcohol		+	+
Butyl acrylate		+	/
Butylbenzyl phthalate		+	+
Butylene glycol	technically pure	+	+
Butyric acid, aqueous	All	+	/
Butylphenol	technically pure	+	+
Calcium carbide		+	+
Calcium carbonate		+	+
Calcium chloride, aqueous	All	+	+
Calcium hydroxide		+	+
Calcium hypochlorite, aqueous (susp.)	All	+	+
Calcium nitrate, aqueous	50%	+	+
Calcium oxide (powder)		+	+
Calcium phosphate		+	+
Calcium sulphate		+	+
Camphor		+	/
Camphor oil		-	
Cane sugar		+	+
Carbazole		+	+
Carbolic acid		+	+ D
Carbolium for fruit trees, aqueous		+ D	/
Carbon dioxide	100%	+	+
Carbon disulphide		/	
Carbonic acid, aqueous	All	+	+
Carbonic acid, dry	100%	+	+
Carbon tetrachloride	technically pure	/ to -	-
Castor oil		+	+
Caustic potash		+	+
Caustic potash solution	50%	+	+
Caustic soda		+	+
Caustic soda solution	All	+	+
Cetyl alcohol (hexadecanol)		+	+
Chloral hydrate, aqueous	all	+	+ D
Chlorine bleach liquor containing 12.5% active chlorine		+ to /	-
Chlorine, gaseous, dry		/	-
Chlorine, gaseous, moist		/	-
Chlorine, liquid		-	
Chlorine water		+	/
Chloroacetic acid (mono), aqueous	all	+	+
Chlorobenzene		/	-
Chlorocarbonic acid		+	/
Chloroethanol	technically pure	+	+ D
Chloroform	technically pure	/ to -	-
Chloropicrin		+ to /	-
Chlorosulphonic acid		-	

Substance	POLYETHYLENE		
	Concentration	68°F	140°F
Chrome anode mud		+	+
Chrome salts, aqueous	all	+	+
Chromic acid, aqueous	up to 50%	+	- D
Chrome alum, aqueous	all	+	+
Chromium trioxide, aqueous	up to 50%	+	- D
Chromosulphuric acid		+	-
Cider		+	+
Citric acid, aqueous	saturated	+	+
Citrus juices		+	+
Clophen A 50 and A 60		+	/ to -
Coal-tar oil		+ D	/
Coconut oil		+	/
Coconut oil fatty alcohol	technically pure	+	/
Codliver oil		+	/
Coffee extract		+	+
Cognac		+	+
Cola concentrates		+	+
Common salt, aqueous	all	+	+
Copper chloride, aqueous		+	+
Copper fluoride, aqueous		+	+
Copper nitrate, aqueous	30%	+	+
Copper salts, aqueous	cold saturated	+	+
Copper sulphate, aqueous	all	+	+
Corn oil		+	/
Corn syrup		+	+
Coumarone resins		+	+
Creosote		+	+ D
Cresol	100%	+	/
Cresol, aqueous	diluted	+	+ D
Crop protection agents, aqueous		+	+
Crotonaldehyde	technically pure	+	/
Cyclanone (fatty alcohol sulphionate)		+	+
Cyclohexane		+	+
Cyclohexanol		+	+
Cyclohexanone		+	/
Decahydronaphthalene (Decalin)	technically pure	+	/
Defoamers		+	+ to /
Detergents		+	+
Detergents, synthetic		+	+
Developer solutions (photographic)		+ D	+ D
Dextrin, aqueous	18%	+	+
Dextrose		+	+
Dextrose, aqueous	all	+	+
1 2-Dibromoethane		/	-
Dibutyl ether		+ to /	-
Dibutyl phthalate	technically pure	+	/
Dibutyl sebacate		+	/
Dichloroacetic acid	technically pure	+	/
Dichloroacetic acid	50%	+	+
Dichloroacetic acid methyl ester		+	+
Dichlorobenzene		/	-
Dichloroethane		/	/
Dichlorodiphenyltrichloroethane (DDT, powder)		+	+
Dichloroethylene		-	-
Dichloropropane		/	-
Dichloropropene		/	-
Diesel fuel		+	/
Diethylene glycol		+	+
Diethyl ether		+ to /	/*
Di (2-ethylhexyl) phthalate (DOP)		+	/
Diethyl ether		+ to /	/*
Diethyl ketone		+	/
Diglycolic acid, aqueous	30%	+	+
Diisobutyl ketone	technically pure	+	/ to -
Diisopropyl ether		+ to /	-
Dimethylamine		+	/
Dimethyl formamide	technically pure	+	+ to /
Dimethyl sulphoxide		+	+
Diocetyl phthalate		+	/
Dioxane		+	+
Diphenylamine		+	/
Diphenyl oxide		+	/
Dishwashing liquids		+	+
Disodium phosphate		+	+
Disodium sulphate		+	+
Dispersions, aqueous		+	+
Dodecylbenzenesulphonic acid		+	/
Drilling aid		/	/

Substance	POLYETHYLENE		
	Concentration	68°F	140°F
Drinking water (also chlorinated)		+	+
Dyes		+ D	+ D
Eau de Javelle		+ to /	-
Electrolyte baths for the plating industry		+ to /	/
Emulsifiers		+	+
Emulsions (photographic)		+	+
Ephetin, aqueous	10%	+	+
Epichlorohydrin		+	+
Epsom salts	all	+	+
Essential oils		-	-
Esters, aliphatic	technically pure	+	+ to /
Ethane		+	+
Ethanol	96%	+	+
Ether		+ to /	/*
Ethyl acetate	technically pure	+	/
Ethyl alcohol	96%	+	+
Ethyl alcohol + acetic acid (fermentation mixture)		+	+
Ethylbenzene	technically pure	/	
Ethyl chloride	technically pure	/*	
Ethyl ether	technically pure	+ to /	/*
Ethylene		+	/
Ethylenediamine	technically pure	+	+
Ethylenediamine tetraacetic acid		+	+
Ethyl dibromide		/	-
Ethylene dichloride (dichloroethane)		/	-
Ethylene glycol		+	+
Ethylene oxide, gaseous	technically pure	+	+
2-Ethylhexanol		+	/
Euron B		/	/
Euron G		+	+
Fatty acid amides		+	/
Fatty acids (>C6)		+	+ to /
Fatty alcohols		+	/
Ferric chloride, aqueous	all	+	+
Ferrous sulphate, aqueous	all	+	+
Fertilizer salts, aqueous	all	+	+
Fir wood oil		+	/
Fluoboric acid, aqueous		+	/ 25%
Fluorine, gaseous		-	
Fluosilicic acid	all	+	+
Formic acid, aqueous	10%	+	+
Formic acid, aqueous	85%	+	+
Formaldehyde, aqueous	up to 40%	+	+
Formamide		+	+
Frigen 12 (Freon 12)	100%	/	-
Fruit juices, fermented	all	+	+
Fruit juices, unfermented		+	+
Fruit pulp		+	+
Fuel oil		+	/
Furfural		+	/
Furfuryl alcohol		+	+ D
Gases from roasting, dry	all	+	+
Gases liquor (ammoniacal)		+	+
Gelatin		+	+
Genantin		+	+
Gin		+	+
Glacial acetic acid	technically pure	+	/ D
Glauber's salt, aqueous	all	+	+
Glucose, aqueous	all	+	+
Glue		+	+
Glycerine, aqueous	up to 100%	+	+
Glycerol chlorohydrin		+	+
Glycine		+	+
Glycol, aqueous		+	+
Glycolic acid, aqueous	up to 70%	+	+
Glycolic acid butyl ester		+	+
Glysantin		+	+
Grisiron 8302		/	/
Grisiron 8702		+	+
Halothane		/	/ to -
Heptane		+	/
Hexane		+	/
Hexanetriol		+	+
Honey		+	+
Hydraulic fluid		+	/
Hydrazine hydrate		+	+
Hydrobromic acid, aqueous	50%	+	+
Hydrochloric acid, aqueous	all	+	+

Substance	POLYETHYLENE		
	Concentration	68°F	140°F
Hydrogen chloride gas, dry and moist		+	+
Hydrocyanic acid		+	+
Hydrofluoric acid, aqueous	40%...85%	+	/
Hydrofluosilicic acid, aqueous	all	+	+
Hydrogen	100%	+	+
Hydrogen peroxide, aqueous	10%	/	/
Hydrogen peroxide, aqueous	30%	/	/
Hydrogen peroxide, aqueous	90%	/	-
Hydrogen sulphide, aqueous	saturated	+	+
Hydrogen sulphide, dry	100%	+	+
Hydroquinone		+ D	+ D
Hydrosulphite, aqueous	up to 10%	+	+
Hydroxylamine sulphate, aqueous	12%	+	+
Hypochlorous acid		+ to /	/
Ink		+	+
Iodine - potassium iodide	3% iodine	+	+
Iron (III) chloride, aqueous	all	+	+
Isobutyl alcohol		+	+
Isooctane		+	/
Isopropanol (isopropyl alcohol)	technically pure	+	+
Isopropyl acetate	100%	+	/
Isopropyl ether	technically pure	+ to /	-
Jam		+	+
Kerosene		+	/
Ketones		+ to /	/ to -
Labarraque's solution		+ to /	
Lactic acid, aqueous	10%...96%	+	+
Lactose		+	+
Lanolin (wool fat)		+	+
Latex		+	+
Lead acetate, aqueous	all	+	+
Lead tetraethyl		+	
Lime		+	+
Limewater		+	+
Linseed oil	technically pure	+	+
Liquer		+ to /	-
Liquid manure		+	+
Liquid paraffin		+	+
Liquid soaps		+	+
Lithium bromide		+	+
Lubricating oils	technically pure	+	+ to /
Lysol		+	/
Machine oil		+	/
Magnesium carbonate		+	+
Magnesium chloride, aqueous	all	+	+
Magnesium fluosilicate		+	+
Magnesium hydroxide		+	+
Magnesium iodide		+	+
Magnesium salts, aqueous	all	+	+
Magnesium sulphate, aqueous	all	+	+
Maleic acid, aqueous	up to 100%	+	+
Malic acid, aqueous	50%	+	+
Manganese sulphate		+	+
Margarine		+	+
Mash		+	+
Mayonnaise		+	
Menthol		+	/
Mercuric chloride (corrosive sublimate)		+	+
Mercury		+	+
Mercury salts		+	+
Metallic mordants		+	+
Metal soaps		+	+
Methacrylate		+	+
Methacrylic acid		+	+
Methanol	technically pure	+	+
Methoxy butanol		+	/
Methoxybutyl acetate (Butoxyl)		+	/
Methyl alcohol		+	+
Methylbenzene		/	-
Methyl bromide, gaseous	technically pure	-	
Methyl chloride		/	
Methyl chloride, gaseous	technically pure	/	
Methylcyclohexane		/	/ to -
Methylene chloride		/	/*
Methyl ethyl ketone	technically pure	+	/ to -
Methyl glycol		+	+
Methyl isobutyl ketone		+	/ to -
Methyl methacrylate		+	+

Substance	POLYETHYLENE		
	Concentration	68°F	140°F
4-Methyl pentanol-2		+	+ to / D
Methyl propyl ketone		+	/
n-Methyl pyrrolidone		+	+
Methyl salicylate		+	/
(salicyclic acid methyl ester)			
Methyl sulphuric acid	50%	+	+
Milk		+	+
Mineral oil	without additives	+	+ to /
Mineral spirits, see White spirit			
Mineral water		+	+
Molasses		+	+
Molasses wort		+	+
Monochloroacetic acid		+	/
Monochloroacetic acid ethyl ester		+	+
Monochloroacetic acid methyl ester		+	+
Monochlorobenzene		/	-
Morpholine		+	+
Motor oil (HD oil)		+	+ to /
Mould-release agents		+	+
Mowilith polymer emulsions		+	+
Mustard		+	+
Nail polish remover		+	/
Naphtha		+	/
Naphthalene		+	-
Nickel chloride		+	+
Nickel nitrate		+	+
Nickel salts, aqueous		+	+
Nickel sulphate, aqueous	all	+	+
Nicotine		+	+
Nitric acid	25%	+	+
Nitric acid	50%	/	-
			(100%)
Nitrobenzene		+	/
Nitrocellulose		+	
o-Nitrotolunene		+	/
Nonyl alcohol (nonanol)		+	+
Octyl cresol	technically pure	/	-
Oils, animal and vegetable		+	+ to /
Oils, essential		/	-
Oleic acid		+	/
Oleum	all	-	-
Olive oil		+	+
Optical brighteners		+	+
Orange juice		+	+
Oxalic acid, aqueous	all	+	+
Oxygen	all	+	+
Ozone	50 ppm	/	-
Palmitic acid	70%	+	+
Palmityl alcohol		+	+
Palm-kernal oil		+	+
Paraformaldehyde		+	+
Pentanol		+	
Peppermint oil		+	
Perchloric acid, aqueous	20%	+	+
Perchloric acid, aqueous	50%	+	/
Perchloric acid, aqueous	70%	+	-
Perchloroethylene		/	-
Perfume oils		/	/ to -
Petrol	technically pure	+	+ to /
Petrol/benzene mixture	80/20	+	/
Petroleum		+	/
Petroleum ether		+	/
Phenol		+	+ D
Phenolic resin moulding materials		+	+
Phenylethyl alcohol		+	+
Phenylhydrazine	technically pure	/	/ to -
Phenylhydrazine hydrochloride		+	-
Phenylsulphonate (sodium dodecylbenzenesulphonate)		+	+
Phosgene, gaseous	100%	-	
Phosgene, liquid	100%	-	
Phosphorus oxichloride		+	/
Phosphates, aqueous	all	+	+
Phosphoric acid, aqueous	50%	+	+
Phosphoric acid, aqueous	80%...95%	+	/ D
Phosphorus pentoxide	100%	+	+
Phosphorus trichloride		-	-
Photographic developers		+ D	+ D
Phthalic acid, aqueous	50%	+	+

Substance	POLYETHYLENE		
	Concentration	68°F	140°F
Phthalic acid ester		+	+ to /
Picric acid, aqueous	1%	+	
Pineapple juice		+	+
Pine-needle oil		+	
Plasticizers		+	/
Polyester plasticizers		+	+ to /
Polyester resins		/	-
Polyglycols		+	+
Polysolvan 0 (glycolic acid n-butyl ester)		+	+
Potash alum, aqueous	all	+	+
Potassium bicarbonate, aqueous	all	+	+
Potassium bisulphate, aqueous	all	+	+
Potassium borate, aqueous	1%	+	+
Potassium bromate, aqueous	up to 10%	+	+
Potassium bromide, aqueous	all	+	+
Potassium carbonate, aqueous	all	+	+
Potassium chlorate, aqueous	all	+	+
Potassium chloride, aqueous	all	+	+
Potassium chromate, aqueous	40%	+	+
Potassium cyanide, aqueous	all	+	+
Potassium dichromate, aqueous	all	+	+
Potassium ferricyanide and ferrocyanide, aqueous	all	+	+
Potassium fluoride, aqueous	all	+	+
Potassium hydroxide, aqueous	30%	+	+
Potassium iodide, aqueous	all	+	+
Potassium nitrate, aqueous	all	+	+
Potassium perborate		+	+
Potassium perchlorate, aqueous	1%	+	
Potassium perchlorate, aqueous	up to 10%	+	/
Potassium permanganate	20%	+	+ D
Potassium permanganate, aqueous	up to 6%	+	+ D
Potassium persulphate, aqueous	all	+	+
Potassium sulphate, aqueous	all	+	+
Potassium sulphide		+	+
Potassium sulphite		+	+
Potassium tetracyanocuprate		+	+
Potassium thiosulphate		+	+
Propanol		+	+
i-Propanol (i-propyl alcohol)	technically pure	+	+
n-Propanol (n-propyl alcohol)		+	+
Propargyl alcohol, aqueous	7%	+	+
Propionic acid, aqueous	all	+	+
Propylene dichloride	100%	-	
Propylene glycol		+	+
Propylene oxide		+	+
Pseudocumene		/	/
Pyridine		+	/
Quinine		+	+
Rubber dispersions (Latex)		+	+
Sagrotan		+	/
Salicylic acid		+	+
Saturated steam condensate		+	+
Sauerkraut		+	+
Seawater		+	+
Silicic acid, aqueous	all	+	+
Silicone oil	technically pure	+	+
Silver nitrate		+	+
Silver nitrate, aqueous	all	+	+
Silver salts, aqueous	cold saturated	+	+
Soap solution, aqueous	all	+	+
Soda, aqueous	all	+	+
Sodium acetate, aqueous	all	+	+
Sodium aluminum sulphate		+	+
Sodium benzoate		+	+
Sodium benzoate, aqueous	any	+	+
Sodium bicarbonate		+	+
Sodium bisulphate		+	+
Sodium bisulphite, aqueous	all	+	+
Sodium borate		+	+
Sodium bromide		+	+
Sodium carbonate, aqueous	all	+	+
Sodium chlorate, aqueous	saturated	+	+
Sodium chloride, aqueous	all	+	+
Sodium chlorite, aqueous	50%	+	
Sodium chromate		+	+
Sodium cyanide		+	+
Sodium dichromate		+	+
Sodium dodecylbenzenesulphonate		+	+

Substance	POLYETHYLENE		
	Concentration	68°F	140°F
Sodium ferrocyanide		+	+
Sodium fluoride		+	+
Sodium hexacyanoferrate		+	+
Sodium hydroxide, aqueous	all	+	+
Sodium hydroxide, solid		+	+
Sodium hypochlorite, aqueous with 12.5% active chlorine		/	-
Sodium hypochlorite, dry		+	
Sodium nitrate, aqueous	all	+	+
Sodium nitrite, aqueous	all	+	+
Sodium perborate, aqueous	all	+	/
Sodium perchlorate, aqueous		+	+
Sodium peroxide, aqueous	10%	+	+
Sodium peroxide, aqueous	saturated	/	
Sodium phosphate, aqueous	saturated	+	+
Sodium silicate		+	+
Sodium silicate, aqueous	all	+	+
Sodium sulphate, aqueous	cold saturated	+	+
Sodium sulphide, aqueous	saturated	+	+
Sodium thiosulphate, aqueous (fixing salt)	all	+	+
Sodium thiosulphate, aqueous	saturated	+	+
Sodium thiosulphate, solid (fixing salt)		+	+
Soft soap		+	+
Soyabean oil		+	+
Spermaceti		+	
Spindle oil		+ to /	/
Spirits		+	
Stain removers		+ to /	/
Standard mineral spirit (DIN 51635)		+	/
Starch, aqueous	up to 100%	+	+
Stearic acid		+	/
Styrene		/	-
Succinic acid, aqueous	50%	+	+
Sulphates, aqueous solutions	all	+	+
Sulphur		+	+
Sulphuric acid, aqueous	up to 50%	+	+
Sulphuric acid, aqueous	70%	+	0...70% /
Sulphuric acid, aqueous	80%	+	70...90% /
Sulphuric acid, aqueous	98%	/	90...100% -
Sulphuric ether		+ to /	/*
Sulphur dioxide, aqueous	all	+	+
Sulphur dioxide, dry and moist	all	+	+
Sulphurous acid		+	+
Sulphur trioxide		-	wet, gas, dry
Sulphuryl chloride		-	
Syrup		+	+
Tallow	technically pure	+	+
Tannic acid	10%	+	+
Tartaric acid, aqueous	all	+	+
Tetrabromoethane		/ to -	-
Tetrachloroethane		/ to -	-
Tetrachloroethylene		/ to -	-
Tetrahydrofuran	technically pure	+ to -	-
Tetrahydronaphthalene (Tetralin)	technically pure	+	-
Thioglycolic acid		+	+
Thionyl chloride		-	
Thiophene		/	-
Tin (II) chloride, aqueous	all	+	+
Tincture of iodine, DAB 6 (German pharmacopoeia)		+	/
Toluene	technically pure	/	-
Tomato juice		+	+
Transformer oil	technically pure	+	/
Tributyl phosphate		+	+
Trichloroacetic acid	technically pure	+	/ to -
Trichloroacetic acid, aqueous	50%	+	+
Trichloroethylene	technically pure	+ to /	-
Trichlorobenzene		-	-
Tricresyl phosphate		+	+
Triethanolamine		+	+ D
Triethylene glycol		+	+
Trilon		+	+
Trimethyl borate		+	/ to -
Trimethylpropane, aqueous		+	+

Substance	POLYETHYLENE		
	Concentration	68°F	140°F
Tri-B-chloroethyl phosphate		+	+
Trioctyl phosphate		+	/
Trisodium phosphate		+	+
Turpentine oil	technically pure	+ to /	-
Tutogen U		+	+
Tween 20 and 80		+	-
Two-stroke engine oil		+	/
Urea, aqueous	up to 33%	+	+
Uric acid		+	+
Urine		+	+
Vaseline	technically pure	+ to /	/
Vaseline oil	technically pure	+ to /	/
Vinegar (white vinegar)		+	+
Vinyl acetate		+	+
Viscose spinning solutions		+	+
Vitamin C		+	
Vitamin preparations, dry (powders)		+	
Walnut oil		+	/
Waste gases, containing carbonic acid	all	+	+
Waste gases, containing carbon monoxide		+	+
Waste gases, containing hydrochloric acid	all	+	+
Waste gases, containing hydrogen fluoride	traces	+	+

Substance	POLYETHYLENE		
	Concentration	68°F	140°F
Waste gases, containing nitrosyl sulphuric acid	traces	+	+
Waste gases, containing SO ₂	low	+	+
Waste gases, containing sulphuric acid (moist)	all	+	+
Water, distilled		+	+
Wax alcohols	technically pure	/	/
Waxes		+	+ to /
Whey		+	+
Whiskey		+	
White spirit	technically pure	+ to /	/
Wine		+	
Wine vinegar		+	+
Wood stains		+	+ to /
Xylene		/	-
Yeast		+	+
Zinc carbonate		+	+
Zinc chloride, aqueous	all	+	+
Zinc oxide		+	+
Zinc salts, aqueous	all	+	+
Zinc sludge		+	+
Zinc stearate		+	+
Zinc sulphate, aqueous	all	+	+

Elastomers

Test Procedure

The criteria for the ratings of various elastomers presented here (Natural Rubber, SBR, and EPDM) were primarily volume swell resistance, compression set resistance, and aging resistance. The ratings were developed from specific data or general agreement of the sources identified in the corresponding table enclosed. Several important factors must be considered in the use of rubber parts in service, including:

1. The Temperature of Service: Greater temperatures increase the effect of all chemicals on polymers. The affect of the temperature varies with the polymer and the chemical.
2. Conditions of Service: A compound that swells badly might still function well as a static seal yet fail in dynamic applications.

Numbers used in the following table:	
<i>Number</i>	<i>Description</i>
1	Minor effect
2	Moderate effect
3	Static only
4	Not recommended
–	Insufficient data

Substance	Natural Rubber (NR, IR)	Styrene Butadiene (SBR, BR)	Ethylene Propylene (EPM, EPDM)
Acetaldehyde	2	3	1
Acetamide	4	4	1
Acetic acid, glacial	2	2	1
Acetic acid 30%	2	2	1
Acetic anhydride	2	2	2
Acetone	3	3	1
Acetophenone	4	4	1
Acetyl chloride	4	4	4
Acetylene	2	2	1
Acrylonitrile	4	4	4
Adipic acid	1	1	1
Alkazene (Dibromoethylbenzene)	4	4	4
Alum-NH3-Cr-K (aq)	1	1	1
Aluminum acetate (aq)	1	2	1
Aluminum chloride (aq)	1	1	1
Aluminum fluoride (aq)	2	1	1
Aluminum nitrate (aq)	1	1	1
Aluminum phosphate (aq)	1	1	1
Aluminum sulfate (aq)	1	1	1
Ammonia anhydrous	4	4	1
Ammonia gas (cold)	1	1	1
Ammonia gas (hot)	4	4	2
Ammonium carbonate (aq)	1	1	-
Ammonium chloride (aq)	1	1	1
Ammonium hydroxide (conc.)	4	4	1
Ammonium nitrate aq)	3	2	1
Ammonium nitrite (aq)	1	1	1
Ammonium persulfate (aq)	1	4	1
Ammonium phosphate (aq)	1	1	1
Ammonium sulfate (aq)	1	1	1
Amyl acetate (banana oil)	4	4	3
Amyl alcohol	2	2	1
Amyl borate	4	4	4
Amyl chloronaphthalene	4	4	4
Amyl naphthalene	4	4	4
Aniline	4	4	1
Aniline dyes	2	2	1
Aniline hydrochloride	2	4	2
Animal fats	4	4	2
Ansul ether (anesthetics)	4	4	3
Aqua regia	4	4	3
Aroclor, 1248	4	4	3
Aroclor, 1254	4	4	3
Aroclor, 1260	1	1	1
Arsenic acid	2	1	1
Arsenic trichloride (aq)	4	4	3
Askarel	4	4	4
Asphalt	4	4	4
Banana oil (amyl acetate)	4	4	3
Barium chloride (aq)	1	1	1
Barium hydroxide (aq)	1	1	1
Barium sulfate (aq)	1	1	1
Barium sulfide (aq)	1	2	1
Beer	1	1	1
Beet sugar liquors	1	1	1
Benzaldehyde	4	4	1
Benzene	4	4	4
Bezene sulfonic acid	4	4	3
Benzine (Ligroin) (Nitrobenzine) (pet ether)	4	4	4
Benzoic acid	4	4	3
Benzoyl chloride	4	4	4
Benzyl alcohol	4	4	1
Benzyl benzoate	4	4	2
Benzyl chloride	4	4	4
Biphenyl (Diphenyl) (Phenylbenzene)	4	4	4
Blast furnace gas	4	4	4
Bleach solutions	4	4	1
Borax	2	2	1
Bordeaux mixture	2	2	1
Boric acid	1	1	1
Brine	1	1	1
Bromine-anhydrous	4	4	4
Bromine trifluoride	4	4	4
Bromine water	4	4	2
Bromobenzene	4	4	4
Binker oil	4	4	4

Substance	Natural Rubber (NR, IR)	Styrene Butadiene (SBR, BR)	Ethylene Propylene (EPM, EPDM)
Butadiene	4	4	3
Butane	4	4	4
Butter (animal fat)	4	4	1
Butyl acetate	4	4	3
Butyl acetyl ricinoleate	4	4	1
Butyl acrylate	4	4	4
Butyl alcohol	1	1	2
Butyl amine	4	4	2
Butyl benzoate	3	2	2
Butyl carbitol	4	4	1
Butyl cellulolve	4	4	1
Butyl oleate	4	4	2
Butyl stearate	4	4	3
Butylene	4	4	4
Butyraldehyde	4	4	2
Calcium acetate (aq)	1	4	1
Calcium bisulfite (aq)	4	4	4
Calcium chloride (aq)	1	1	1
Calcium hydroxide (aq)	1	1	1
Calcium hypochlorite (aq)	3	3	1
Calcium nitrate (aq)	1	1	1
Calcium sulfide (aq)	2	2	1
Cane sugar liquors	1	1	1
Carbamate	4	4	2
Carbitol	2	2	2
Carbolic acid (phenol)	4	4	2
Carbon bisulfide	4	4	4
Carbon dioxide	2	2	2
Carbonic acid	1	2	1
Carbon monoxide	2	2	1
Carbon tetrachloride	4	4	4
Castor oil	1	1	2
Cellosolve	4	4	2
Cellosolve acetate	4	4	2
Cellulube (Fryquel)	4	4	1
China wood oil (Tung oil)	4	4	3
Chlorine (dry)	4	4	4
Chlorine (wet)	4	4	3
Chlorine dioxide	4	4	3
Chlorine trifluoride	4	4	4
Chloroacetic acid	4	4	1
Chloroacetone	4	4	1
Chlorobenzene	4	4	4
Chlorobromomethane	4	4	2
Chlorobutadiene	4	4	4
Chlorododecane	4	4	4
Chloroform	4	4	4
O-Chloronaphthalene	4	4	4
1-Chloro-1-Nitro ethane	4	4	4
Chlorosulfonic acid	4	4	4
Chlorotoluene	4	4	4
Chlorox (sodium hypochlorite NaOCl)	4	4	2
Chrome plating solutions	4	4	2
Chromic acid	4	4	3
Citric acid	1	1	1
Coal tar (creosote)	4	4	4
Cobalt chloride (aq)	1	1	1
Coconut oil	4	4	3
Cod liver oil	4	4	1
Coke oven gas	4	4	4
Copper acetate (aq)	1	4	1
Copper chloride (aq)	1	1	1
Copper cyanide (aq)	1	1	1
Copper sulfate (aq)	2	2	1
Cornoil	4	4	3
Cottonseed oil	4	4	2
Creosote (Coal tar)	4	4	4
Cresol	4	4	4
Cresylic acid	4	4	4
Cumene	4	4	4
Cyclohexane	4	4	4
Cyclohexanol	4	4	3
Cyclohexanone	4	4	2
P-Cymene	4	4	4
Decalin	4	4	4
Decane	4	4	4
Denatured alcohol	1	1	1

Substance	Natural Rubber (NR, IR)	Styrene Butadiene (SBR, BR)	Ethylene Propylene (EPM, EPDM)
Detergent solutions	2	2	1
Developing fluids	1	2	2
Diacetone	4	4	1
Diacetone alcohol	4	4	1
Dibenzyl ether	4	4	2
Dibenzyl sebacate	4	4	2
Dibromoethylbenzene (Alkazene)	4	4	4
Dibutyl amine	4	4	3
Dibutyl ether	4	4	3
Dibutyl phthalate	4	4	2
Dibutyl sebecate	4	4	2
O-Dichlorobenzene	4	4	4
Dichloro-isopropyl ether	4	4	3
Dicyclohexylamine	4	4	4
Diesel oil	4	4	4
Diethylamine	2	2	2
Diethyl benzene	4	4	4
Diethyl ether	4	4	4
Diethylene glycol	1	1	1
Diethyl sebacate	4	4	2
Diisobutylene	4	4	4
Diisopropyl benzene	4	4	4
Diisopropyl ketone	4	4	1
Diisopropylidene acetone (Phorone)	4	4	3
Dimethyl aniline (Xylidene)	3	3	2
Dimethyl ether (methyl ether) (monomethyl ether)	4	4	4
Dimethyl formamide	4	4	2
Dimethyl phthalate	4	4	2
Dinitrotoluene	4	4	4
Diocetyl Phthalate	4	4	2
Diocetyl Sebecate	4	4	2
Dioxane	4	4	2
Dioxolane	4	4	2
Dipentene	4	4	4
Diphenyl (Biphenyl) (Phenylbenzene)	4	4	4
Diphenyl oxides	4	4	4
Dowtherm oil	4	4	4
Dry cleaning fluids	4	4	4
Epichlorohydrin	4	4	2
Ethane	4	4	4
Ethanolamine	2	2	2
Ethyl acetate	4	4	2
Ethyl acetoacetate	3	3	2
Ethyl acrylate	4	4	2
Ethyl alcohol	1	1	1
Ethyl benzene	4	4	4
Ethyl benzoate	1	1	1
Ethyl cellosolve	4	4	4
Ethyl cellulose	2	2	2
Ethyl chloride	4	4	3
Ethyl chlorocarbonate	4	4	2
Ethyl chloroformate	4	4	2
Ethyl ether	4	4	3
Ethyl formate	4	4	2
Ethyl mercaptan	4	4	3
Ethyl oxalate	1	1	1
Ethyl pentachlorobenzene	4	4	4
Ethyl silicate	2	2	1
Ethylene	3	3	2
Ethylene chloride	4	4	3
Ethylene chlorohydrin	2	2	2
Ethylene diamine	1	2	1
Ethylene dichloride	4	4	3
Ethylene glycol	1	1	1
Ethylene oxide	4	4	3
Ethylene trichloride	4	4	3
Fatty acids	4	4	3
Ferric chloride (aq)	1	1	1
Ferric nitrate (aq)	1	1	1
Ferric sulfate (aq)	1	1	1
Fishoil	4	4	4
Fluorinated cyclic ethers	4	4	1
Fluorine (liquid)	4	4	4
Fluorobenzene	4	4	4
Fluoroboric acid	1	1	1

Substance	Natural Rubber (NR, IR)	Styrene Butadiene (SBR, BR)	Ethylene Propylene (EPM, EPDM)
Fluorocarbon oils	2	2	1
Fluorolube	2	3	1
Fluorosilicic acid (hydrofluosilicic acid)	2	3	2
Formaldehyde (RT)	2	2	1
Formic acid	2	1	1
Freon 11	4	4	4
Freon 12	2	1	2
Freon 13	1	1	1
Freon 21	4	4	4
Freon 22	2	1	1
Freon 31	2	2	1
Freon 32	1	1	1
Freon 112	4	3	4
Freon 113	3	2	3
Freon 114	1	1	1
Freon 115	1	1	1
Freon 142b	2	2	2
Freon 152a	1	1	1
Freon 218	1	1	1
Freon C316	1	1	1
Freon C318	1	1	1
Freon 13B1	1	1	1
Freon 114B2	4	3	4
Freon 502	1	1	1
Freon TF	4	3	4
Freon T-WD602	4	3	2
Freon TMC	4	4	3
Freon T-P35	1	1	1
Freon TA	3	3	2
Freon TC	4	3	2
Freon MF	4	4	4
Freon BF	4	4	4
Fueloil	4	4	4
Fumaric acid	3	3	2
Furan, furfuran	4	4	3
Furfural	4	4	2
Fyrquel (cellulube)	4	4	1
Gallic acid	1	2	2
Gasoline	4	4	4
Gelatin	1	1	1
Glouber's salt (aq)	2	4	2
Glucose	1	1	1
Glue	2	2	1
Glycerin	1	1	1
Glycols	1	1	1
Green sulfate liquor	2	2	1
Holowax oil	4	4	4
N-Hexaldehyde	4	4	1
Hexane	4	4	4
N-Hexene-1	4	4	4
Hexyl alcohol	2	2	3
Hydrazine	1	1	1
Hydraulic oil (petroleum)	4	4	4
Hydrobromic acid	1	4	1
Hydrobromic acid 40%	1	4	1
Hydrochloric acid (cold) 37%	2	2	1
Hydrochloric acid (hot) 37%	4	4	3
Hydrocyanic acid	2	2	1
Hydrofluoric acid (conc.) cold	4	4	3
Hydrofluoric acid (conc.) hot	4	4	4
Hydrofluoric acid - anhydrous	4	4	3
Hydrofluosilicic acid (fluosilicic acid)	2	3	2
Hydrogen gas	2	1	1
Hydrogen peroxide (90%)	4	4	2
Hydrogen sulfide (wet) cold	4	4	1
Hydrogen sulfide (wet) hot	4	4	1
Hydroquinone	2	4	2
Hypochlorous acid	2	4	2
Iodine pentafluoride	4	4	4
Iodoform	4	4	4
Isobutyl alcohol	1	2	1
Isooctane	4	4	4
Isophorone	4	4	3
Isopropyl acetate	4	4	2
Isopropyl alcohol	1	2	1
Isopropyl chloride	4	4	4

Substance	Natural Rubber (NR, IR)	Styrene Butadiene (SBR, BR)	Ethylene Propylene (EPM, EPDM)
Isopropyl ether	4	4	4
Kerosene	4	4	4
Lacquers	4	4	4
Lacquer solvents	4	4	4
Lactic acid (cold)	1	1	1
Lactic acid (hot)	4	4	4
Lard	4	4	2
Lavender oil	4	4	4
Lead acetate (aq)	1	4	1
Lead nitrate (aq)	1	1	1
Lead sulfamate (aq)	2	2	1
Ligroin (Benzine) (Nitrobenzene) (pet ether)	4	4	4
Lime bleach	1	2	1
Lime sulfur	4	4	1
Lindol (hydraulic fluid)	4	4	1
Linoleic acid	4	4	4
Linseed oil	4	4	3
Liquefied petroleum gas	4	4	4
Lubricating oils (petroleum)	4	4	4
Lye2	2	1	-
Magnesium chloride (aq)	1	1	1
Magnesium hydroxide (aq)	2	2	1
Magnesium sulfate (aq)	2	2	1
Maleic acid	3	3	2
Maleic anhydride	3	3	2
Malic acid	3	3	2
Mercury chloride (aq)	1	1	1
Mercury	1	1	1
Mesityl oxide	4	4	2
Methane	4	4	4
Methyl acetate	3	3	1
Methyl acrylate	4	4	2
Methylacrylic acid	4	4	2
Methyl alcohol	1	1	1
Methyl bromide	4	4	4
Methyl butyl ketone (propyl acetone)	4	4	1
Methyl cellosolve	4	4	2
Methyl chloride	4	4	3
Methyl cyclopentane	4	4	4
Methylene chloride	4	4	3
Methyl ether (dimethyl ether) (monomethyl ether)	4	4	4
Methyl ethyl ketone	4	4	1
Methyl formate	4	4	2
Methyl isobutyl ketone	4	4	2
Methyl methacrylate	4	4	3
Methyl oleate	4	4	2
Methyl salicylate	3	3	2
Milk	1	1	1
Mineral oil	4	4	3
Monochlorobenzene	4	4	4
Monomethyl aniline	4	4	2
Monoethanol amine	2	2	1
Monomethyl ether (methyl ether) (dimethyl ether)	4	4	4
Monovinyl acetylene	2	2	2
Mustard gas	1	2	1
Naphtha	4	4	4
Naphthalene	4	4	4
Naphthalenic acid	4	4	4
Natural gas	2	2	4
Neats foot oil	4	4	2
Neville acid	4	4	2
Nickel acetate (aq)	1	4	1
Nickel chloride (aq)	1	1	1
Nickel sulfate (aq)	2	2	1
Niter cake	1	1	1
Nitric acid (conc.)	4	4	4
Nitric acid (dilute)	4	4	2
Nitric acid - red fuming	4	4	4
Nitrobenzene	4	4	1
Nitrobenzene (petroleum ether)	4	4	4
Nitroethane	2	2	2
Nitrogen	1	1	1
Nitrogen tetroxide	4	4	3
Nitromethane	2	2	2

Substance	Natural Rubber (NR, IR)	Styrene Butadiene (SBR, BR)	Ethylene Propylene (EPM, EPDM)
Octachlorotoluene	4	4	4
Octadecane	4	4	4
N-Octane	4	4	4
Octyl alcohol	2	2	3
Oleic acid	4	4	4
Oleum spirits	4	4	4
Olive oil	4	4	2
O-Dichlorobenzene	4	4	4
Oxalic acid	2	2	1
Oxygen - cold	2	2	1
Oxygen - (200°-400°F)	4	4	3
Ozone	4	4	1
Paint thinner, duco	4	4	4
Palmitic acid	2	2	2
Peanut oil	4	4	3
Perchloric acid	4	4	2
Perchloroethylene	4	4	4
Petroleum - below 250°F	4	4	4
Petroleum - above 250°F	4	4	4
Phenol (carbolic acid)	4	-	2
Phenylbenzene (biphenyl) (diphenyl)	4	4	4
Phenyl ethyl ether	4	4	4
Phenyl hydrazine	1	2	2
Phorane (diisopropylidene acetone)	4	4	3
Phosphoric acid - 20%	2	2	1
Phosphoric acid - 45%	3	3	1
Phosphorus trichloride	4	4	1
Pickling solution	4	4	3
Picric acid	2	2	2
Pinene	4	4	4
Pineoil	4	4	4
Piperidine	4	4	4
Plating solution - chrome	4	4	1
Polyvinyl acetate emulsion	2	4	1
Potassium acetate (aq)	1	4	1
Potassium chloride (aq)	1	1	1
Potassium cupro cyanide (aq)	1	1	1
Potassium cyanide (aq)	1	1	1
Potassium dichromate (aq)	2	2	1
Potassium hydroxide (aq)	2	2	1
Potassium nitrate (aq)	1	1	1
Potassium sulfate (aq)	2	1	1
Producer gas	4	4	4
Propane	4	4	4
i-Propyl acetate	4	4	2
n-Propyl acetate	4	4	2
Propyl acetone (methyl butyl ketone)	4	4	1
Propyl alcohol	1	1	1
Propyl nitrate	4	4	2
Propylene	4	4	4
Propylene oxide	4	4	2
Pydraul, 10E, 29 ELT	4	4	1
Pydraul, 30E, 50E, 65E, 90E	4	4	1
Pydraul, 115E	4	4	1
Pydraul, 230E, 312C, 540C	4	4	4
Pyranol, transformer oil	4	4	4
Pyridine	4	4	2
Pyroigneous acid	4	4	2
Pyrrole	3	3	3
Radiation	3	3	2
Rapeseed oil	4	4	1
Red oil (MIL-H-5606)	4	4	4
RJ-1 (MIL-F-25558 B)	4	4	4
RP-1 (MIL-F-25576 C)	4	4	4
Sal ammoniac	1	1	1
Salicylic acid	1	2	1
Salt water	1	1	1
Sewage	2	2	2
Silicate esters	4	4	4
Silicone greases	1	1	1
Silicone oils	1	1	1
Silver nitrate	1	1	1
Skydrol 55	4	4	1
Skydrol 7000	4	4	1
Soap solutions	2	1	1

Substance	Natural Rubber (NR, IR)	Styrene Butadiene (SBR, BR)	Ethylene Propylene (EPM, EPDM)
Soda ash	1	1	1
Sodium acetate (aq)	1	4	1
Sodium bicarbonate (aq) (baking soda)	1	1	1
Sodium bisulfite (aq)	1	2	1
Sodium borate (aq)	1	1	1
Sodium chloride (aq)	1	1	1
Sodium cyanide (aq)	1	1	1
Sodium hydroxide (aq)	1	1	1
Sodium hypochlorite (aq) (Clorox)	4	4	2
Sodium metaphosphate (aq)	1	1	1
Sodium nitrate (aq)	2	1	1
Sodium perborate (aq)	2	2	1
Sodium peroxide (aq)	2	2	1
Sodium phosphate (aq)	1	1	1
Sodium silicate (aq)	1	1	1
Sodium sulfate (aq)	2	2	1
Sodium thiosulfate (aq)	2	2	1
Soybean oil	4	4	3
Stannic chloride (aq)	1	1	1
Stannous chloride (aq)	1	1	1
Steam under 300°F	4	4	1
Steam over 300°F	4	4	3
Stearic acid	2	2	2
Stoddard solvent	4	4	4
Styrene	4	4	4
Sucrose solution	1	1	1
Sulfite liquors	2	2	2
Sulfur	4	4	1
Sulfur chloride (aq)	4	4	4
Sulfur dioxide (dry)	2	2	1
Sulfur dioxide (wet)	4	4	1
Sulfur dioxide (liquified under pressure)	4	4	1
Sulfur hexafluoride	4	4	1
Sulfur trioxide	2	2	2
Sulfuric acid (dilute)	3	3	2
Sulfuric acid (conc.)	4	4	3
Sulfuric acid (20% oleum)	4	4	4
Sulfurous acid	2	2	2
Tannic acid	1	2	1
Tar, bituminous	4	4	3
Tartaric acid	3	4	2
Terpineol	4	4	3
Tertiary butyl alcohol	2	2	2
Tertiary butyl catechol	4	2	2
Tertiary butyl mercaptan	4	4	4
Tetrabromoethane	4	4	4
Tetrabromomethane	4	4	4
Tetrabutyl titanate	2	2	1
Tetrachloroethylene	4	4	4
Tetraethyl lead	4	4	4
Tetrahydrofuran	4	4	3
Tetralin	4	4	4
Thionyl chloride	4	4	3
Titanium tetrachloride	4	4	4
Toluene	4	4	4
Toluene diisocyanate	4	4	2
Transformer oil	4	4	4
Transmission fluid type A	4	4	4
Triacetin	2	2	1
Triaryl phosphate	4	4	1
Tributoxy ethyl phosphate	2	2	1
Tributyl mercaptan	4	4	4
Tributyl phosphate	2	4	2
Trichloroacetic acid	3	2	2
Trichloroethane	4	4	4
Trichlorethylene	4	4	4
Tricresyl phosphate	4	1	4
Triethanol amine	2	2	1
Triethyl aluminum	4	4	3
Triethyl borane	4	4	3
Trinitrotoluene	4	4	4
Trioctyl phosphate	4	4	1
Tung oil (China wood oil)	4	4	3
Turbine oil	4	4	4
Turpentine	4	4	4

Substance	Natural Rubber (NR, IR)	Styrene Butadiene (SBR, BR)	Ethylene Propylene (EPM, EPDM)
Unsymmetrical dimethyl hydrazine (UDMH)	1	1	1
Varnish	4	4	4
Vegetable oils	4	4	3
Versilube F-50	1	1	1
Vinegar	2	2	1
Vinyl chloride	4	4	4
Wagner 21B brake fluid	2	1	1
Water	1	1	1
Whiskey, wines	1	1	1
White pine oil	4	4	4
White oil	4	4	4
Woodoil	4	4	4
Xylene	4	4	4
Xylidine (Di-methyl aniline)	3	3	2
Zeolites	1	1	1
Zinc acetate (aq)	1	4	1
Zinc chloride (aq)	1	1	1
Zinc sulfate (aq)	2	2	1
TT-T-656b	4	4	1
VV-B-680	2	1	1
VV-G-632	4	4	4
VV-G-671c	4	4	4
VV-H-910	2	1	1
VV-I-530a	4	4	4
VV-K-211d	4	4	4
VV-K-220a	4	4	4
VV-L-751b	4	4	4
VV-L-800	4	4	4
VV-L-820b	4	4	4
VV-L-825a type I	4	4	4
VV-L-825a type II	4	4	4
VV-L-825a type III	4	4	4
VV-O-526	4	4	4
VV-P-216a	4	4	4
VV-P-236	4	4	4
51-F-23	4	4	4
ASTM Method D-471			
1	4	4	4
2	4	4	4
3	4	4	4
MIL-L-644 B	3	3	3
MIL-L-2104 B	4	4	4
MIL-L-2105 B	4	4	4
MIL-G-2108	4	4	4
MIL-S-3136 B type I	4	4	4
MIL-S-3136 B type II	4	4	4
MIL-S-3136 B type III	4	4	4
MIL-S-3136 B type IV	4	4	4
MIL-S-3136 B type V	4	4	4
MIL-S-3136 B type VI	4	4	4
MIL-S-3136 B type VII	4	4	4
MIL-L-3150 A	4	4	4
MIL-L-3503	4	4	4
MIL-L-3545 B	4	4	4
MIL-C-4339 C	4	4	4
MIL-G-4343 B	4	4	3
MIL-L-5020 A	4	4	4
MIL-J-5161 F	4	4	4
MIL-C-5545 A	4	4	4
MIL-H-5559 A	2	1	1
MIL-F-5566	1	1	1
MIL-F-5602	4	4	4
MIL-H-5606 B (red oil)	4	4	4
MIL-J-5624 G JP-3, JP-4, JP-5	4	4	4
MIL-O-6081 C	4	4	4
MIL-L-6082 C	4	4	4
MIL-H-6083 C	4	4	4
MIL-L-6085 A	4	4	4
MIL-L-6086 B	4	4	4
MIL-L-6387 A	4	4	4
MIL-C-6529 C	4	4	4
MIL-F-7024 A	4	4	4
MIL-H-7083 A	2	1	1
MIL-G-7118 A	4	4	4
MIL-G-7187	4	4	4
MIL-G-7421 A	4	4	4
MIL-H-7644	2	1	1

Substance	Natural Rubber (NR, IR)	Styrene Butadiene (SBR, BR)	Ethylene Propylene (EPM, EPDM)
MIL-L-7645	4	4	4
MIL-G-7711 A	4	4	4
MIL-L-7808 F	4	4	4
MIL-L-7870 A	4	4	4
MIL-C-8188 C	4	4	4
MIL-A-8243 B	2	1	1
MIL-L-8383 B	4	4	4
MIL-H-8446 B (MLO-8515)	4	4	4
MIL-L-8660 B	1	1	1
MIL-L-9000 F	4	4	4
MIL-T-9188 B	4	4	1
MIL-L-9236 B	3	3	3
MIL-L-10295 A	4	4	4
MIL-L-10324 A	4	4	4
MIL-G-10294 B	4	4	4
MIL-L-11734 B	4	4	4
MIL-O-11773	4	4	4
MIL-P-12098	2	1	1
MIL-H-13862	4	4	4
MIL-H-13866 A	4	4	4
MIL-H-13910 B	2	1	1
MIL-H-13919 A	4	4	4
MIL-L-14107 B	4	4	4
MIL-L-15017	4	4	4
MIL-L-15015 B	4	4	4
MIL-L-15019 C	4	4	4
MIL-L-15719 A	3	2	2
MIL-G-15793	4	4	4
MIL-F-16929 A	4	4	4
MIL-L-16958 A	4	4	4
MIL-F-17111	4	4	4
MIL-L-17331 D	4	4	4
MIL-L-17353 A	4	4	4
MIL-L-17672 B	4	4	4
MIL-L-18486 A	4	4	4
MIL-G-18709 A	4	4	4
MIL-H-19457 B	4	4	1
MIL-F-19605	4	4	4
MIL-L-19701	4	4	4
MIL-21260	4	4	4
MIL-S-21568 A	2	1	1
MIL-H-22072	2	1	1
MIL-L-22396	4	4	4

Substance	Natural Rubber (NR, IR)	Styrene Butadiene (SBR, BR)	Ethylene Propylene (EPM, EPDM)
MIL-L-23699 A	4	4	4
MIL-G-23827 A	4	4	4
MIL-G-25013 D	2	1	1
MIL-F-25172	4	4	4
MIL-L-25336 B	4	4	4
MIL-F-25524 A	4	4	4
MIL-G-25537 A	4	4	4
MIL-F-25558 B (RJ-1)	4	4	4
MIL-F-25576 C (RP-1)	4	4	4
MIL-L-25598	4	4	4
MIL-F-25656 B	4	4	4
MIL-L-25681 C	2	1	1
MIL-G-25760 A	3	3	4
MIL-L-25968	4	4	4
MIL-L-26087 A	4	4	4
MIL-G-27343	1	1	1
MIL-H-27601 A	4	4	4
MIL-G-27617	-	2	1
MIL-I-27686 D	2	1	1
MIL-L-27694 A	1	1	1
MIL-L-46000 A	4	4	4
MIL-H-46001 A	4	4	4
MIL-L-46002	4	4	4
MIL-H-46004	4	4	4
MIL-P-46046 A	2	1	1
MIL-H-81019 B	4	4	4
MIL-S-81087	1	1	1
O-A-548 a	2	1	1
O-T-634 b	4	4	4
P-S-661 b	4	4	4
P-D-680	4	4	4
TT-N-95 a	4	4	4
TT-N-97 b	4	4	4
TT-I-735 b	1	1	1
TT-S-735 type I	4	4	4
TT-S-735 type II	4	4	4
TT-S-735 type III	4	4	4
TT-S-735 type IV	4	4	4
TT-S-735 type V	4	4	4
TT-S-735 type VI	4	4	4
TT-S-735 type VI	4	4	4

Technical Resources

1. LyondellBasell. (August 2003). Resistance to Chemicals and Other Media. Product Brochure.
2. Simport (13 February 2007). Chemical Resistance Charts [On-line]. Available WWW: <http://www.simport.com/en/charts.php>
3. Borealis (13 February 2007). Chemical Resistance Table: Low Density and High Density Polyethylene [On-line]. Available WWW: http://www.borealisgroup.com/public/pdf/customer_centre/Chemical-resistance-hdpe-ldpe.pdf
4. TexLoc (13 February 2007). Chemical Resistance [On-line]. Available WWW: http://www.texloc.com/cl_chemicalsummary.html
5. Baxter Rubber Company (19 August 2009). Chemical Resistance Guide [On-line]. Available: <http://www.baxterrubber.com/resistance.html>



Technical Note

TN 4.02 Chemical Resistance of Polypropylene and Elastomers

The results reported herein are of testing performed on polypropylene (PP) material, compiled from multiple sources. A listing of sources is available at the conclusion of this document. Actual results may vary on the environmental conditions for each particular application. In evaluating the capability of polypropylene pipe, fittings, and manholes to withstand chemical attack, consideration should be given to the following:

1. The effect of an active substance on polypropylene is not as severe when contact is intermittent.
2. Increasing temperature increases chemical activity.
3. Internal pressure may affect the rate of penetration of a substance.
4. Excessive bending and other stresses resulting from improper installation may affect the life of polypropylene products. An example would be circumferential deflection beyond 50% or placing pipe directly on a large, sharp rock.

This listing contains accurate and reliable information to the best of our knowledge. The data contained herein is a compilation of studies conducted by various sources which Advanced Drainage Systems believes to be reliable. However, the information cannot be guaranteed because the conditions of use are beyond our control. The user of this information assumes all risk associated with its use.

Polypropylene

Test Procedure

Polypropylene specimens were placed in the relevant substance for a period of time without the application of mechanical stress. They were then tested for swelling or weight loss and subjected to tensile testing. In critical applications, it is suggested that greater reliance be placed on actual field experience or testing should be performed under similar conditions of stress, exposure, temperature and duration which can be related to the anticipated application. Data regarding resistance to chemicals not listed may be available by contacting an ADS representative.

Symbols used in the following table:	
Symbol	Description
+	specimen is resistant swelling < 3% or alternatively weight loss < 0.5%, elongation of break not significantly changed
/	specimen has limited swelling 3 - 8% or alternatively weight resistance only loss 0.5 - 5%, and/or elongation at break decreased by < 50%
-	specimen is not resistant swelling > 8% or alternatively weight loss > 5%, and/or elongation a break decreased by > 50%
D	discoloration
*	or at the boil

Substance	POLYPROPYLENE		
	Concentration	68°F	140°F
Acetaldehyde		/	–
Acetic acid (glacial)	97%	+	/ (176°)
Acetic acid	50%	+	+ (176°)
Acetic acid	40%	+	
Acetic acid	10%	+	+
Acetone	100%	+	+
Acetophenone	100%	/	/
Acrylic emulsions		+	+
Aluminum chloride		+	+
Aluminum fluoride		+	+
Aluminum sulfate		+	+
Alums (all types)		+	+
Ammonia gas (dry)		+	+
Ammonia, aqueous	30%	+	
Ammonium carbonate	All	+	+
Ammonium chloride	All	+	+
Ammonium fluoride	20%	+	+
Ammonium hydroxide	28%	+	+
Ammonium metaphosphate		+	+
Ammonium nitrate	All	+	+
Ammonium persulfate	All	+	+
Ammonium sulphate	All	+	+
Ammonium sulphide	All	+	+
Ammonium thiocyanate		+	+
Amyl acetate	100%	/	–
Amyl alcohol	100%	+	/
Amyl chloride	100%	–	–
Aniline	100%	+	+
Anisole		/	/ to –
Antimony chloride		+	+
Aviation fuel (115/145 octane)	100%	/	–
Aviation turbine fuel	100%	/	–
Barium carbonate		+	+
Barium chloride		+	+
Barium hydroxide		+	+
Barium sulfate		+	+
Barium sulfide		+	+
Beer		+	+
Benzene	100%	/	–
Benzoic acid	all	+	+
Benzyl alcohol		+	+ (176°)
Benzyl chloride		/	–
Bismuth carbonate		+	+
Borax		+	+
Boric acid	all	+	+
Brine	saturated	+	+
Bromine, liquid	100%	–	–
Bromine water	saturated	–	–
Butyl acetate	100%	–	–
Butyl alcohol		+	+
Calcium carbonate		+	+
Calcium chlorate		+	+
Calcium chloride	50%	+	+
Calcium hydroxide		+	+
Calcium hypochlorite bleach	20% (a)	+	/
Calcium nitrate	50%	+	+
Calcium phosphate	50%	+	
Calcium sulphate		+	+
Carbon dioxide (dry)	100%	+	+
Carbon dioxide (wet)	100%	+	+
Carbon disulphide		/	–
Carbon monoxide		+	+
Carbon tetrachloride	100%	–	–
Carbonic acid	All	+	+
Castor oil		+	
Cetyl alcohol (hexadecanol)	100%	+	
Chlorine, gaseous		–	–
Chlorine water		+	/
Chlorobenzene		–	–
Chloroform	100%	–	–
Chlorosulphonic acid		–	–
Chrome alum		+	+
Chromic acid	80% (a)	+	
Chromic acid	50% (a)	+	+
Chromic acid	10% (a)	+	+
Chromic/sulfuric acid	10%	–	–
Cider		+	+
Citric acid	10%	+	+

Substance	POLYPROPYLENE		
	Concentration	68°F	140°F
Citrus juices		+	+
Copper chloride	saturated	+	+
Copper cyanide	saturated	+	+
Copper fluoride	saturated	+	+
Copper nitrate	saturated	+	+
Copper sulphate	all	+	+
Cotton seed oil		+	+
Cuprous chloride	saturated	+	+
Cyclohexanol		+	+
Cyclohexanone		/	–
Decahydronaphthalene (Decalin)	100%	–	–
Detergents	2%	+	+
Developer solutions (photographic)		+	+
Dibutyl phthalate	100%	+	/ (– 212°)
Dichloroethylene	100%	+	
Diethanolamine	100%	+	+
Diisooctyl phthalate	100%	+	+
Dioxane		+	/
Emulsifiers		+	+
Ethanolamine	100%	+	+
Ethyl acetate	100%	/	/
Ethyl alcohol	96%	+	+
Ethyl chloride	100%	–	–
Ethyl dichloride	100%	/	
Ethylene glycol		+	+
Ethylene oxide	100%	/ (50°)	
Ethyl ether	100%	/	
Fatty acids (>C6)	100%	+	+
Ferric chloride	all	+	+
Ferric nitrate	saturated	+	+
Ferric sulfate	saturated	+	+
Ferrous chloride	saturated	+	+
Ferrous sulfate	all	+	+
Fluosilicic acid		+	+
Formaldehyde	40%	+	+
Formic acid	10%	+	+
Formic acid	100%	+	
Fructose		+	+
Fruit juices		+	+
Fual oil		+	+
Furfural		–	–
Gases liquor		–	
Gasoline	100%	/	–
Gearbox oil	100%	+	/
Gelatin		+	+
Glucose	20%	+	+
Glycerine	100%	+	+
Glycol		+	+
Hexane	100%	+	/
Hydrobromic acid	50% (a)	+	+
Hydrochloric acid	30% (a)	+	/
Hydrochloric acid	Up to 20%	+	+
Hydrofluoric acid	40%	+	+
Hydrofluoric acid	60% (a)	+	+
Hydrogen peroxide, aqueous	30%	+	
Hydrogen peroxide, aqueous	10%	+	/
Hydrogen peroxide, aqueous	3%	+	
Hydrogen sulfide		+	+
Hydroquinone		+	+
Ink		+	+
Iodine tincture		+	
Isooctane	100%	–	–
Isopropanol (isopropyl alcohol)	100%	+	+
Ketones		+	
Lactic acid	20%	+	+
Lanolin (wool fat)		+	+
Lead acetate	saturated	+	+
Linseed oil	100%	+	+
Lubricating oils	100%	+	/

Substance	POLYPROPYLENE		
	Concentration	68°F	140°F
Magenta dye, aqueous	2%	+	+ D
Magnesium carbonate	saturated	+	+
Magnesium chloride	saturated	+	+
Magnesium hydroxide	saturated	+	+
Magnesium sulfate	saturated	+	+
Magnesium sulfite	saturated	+	+
Meat juices		+	+
Mercuric chloride (corrosive sublimate)	40%	+	+
Mercuric cyanide	saturated	+	+
Mercurous nitrate	saturated	+	+
Mercury	100%	+	+
Methyl alcohol	100%	+	+
Methylbenzene		/	-
Methylene chloride	100%	+	
Methyl ethyl ketone	100%	+	/
Milk		+	+ (+ 212°)
Mineral oil	100%	+	/
Molasses		+	+
Motor oil (HD oil)	100%	+	/
Naphthalene	100%	+	+
Nickel chloride	saturated	+	+
Nickel nitrate	saturated	+	+
Nickel sulphate, aqueous	saturated	+	+
Nitric acid	70% (a)	-	-
Nitric acid	60%	+	-
Nitric acid	10%	+	+
Nitrobenzene		+	/
Oleic acid		+	/
Oleum			- (212°)
Olive oil	saturated	+	+
Oxalic acid, aqueous	50%	+	/
Paraffin	100%	+	/
Paraffin wax	100%	+	+
Perchloric acid	20%	+	-
Petrol	100%	/	-
Petroleum ether	100%	-	-
Phenol	100%	+	+ D
Phosphoric acid, aqueous	95%	+	+
Photographic developer		+	+
Potassium bicarbonate, aqueous	saturated	+	+
Potassium borate, aqueous	1%	+	+
Potassium bromate, aqueous	up to 10%	+	+
Potassium bromide, aqueous	saturated	+	+
Potassium carbonate, aqueous	saturated	+	+
Potassium chlorate, aqueous	saturated	+	+
Potassium chloride, aqueous	saturated	+	+
Potassium chromate, aqueous	40%	+	+
Potassium cyanide, aqueous	saturated	+	+
Potassium dichromate, aqueous	40%	+	+
Potassium ferricyanide and ferrocyanide, aqueous	saturated	+	+
Potassium fluoride, aqueous		+	+
Potassium hydroxide, aqueous	50%	+	+
Potassium nitrate, aqueous	saturated	+	+
Potassium perborate	saturated	+	+
Potassium perchlorate, aqueous	up to 10%	+	+
Potassium permanganate	20%	+	+
Potassium sulfate, aqueous		+	+
Potassium sulfide		+	+
Potassium sulfite		+	+
Propanol (propyl alcohol)	100%	+	+
Pyridine		+	
Silicone oil	100%	+	+
Silver nitrate		+	+
Soap solution, aqueous		+	+
Sodium acetate, aqueous	all	+	+
Sodium bicarbonate	saturated	+	+
Sodium bisulphate	saturated	+	+
Sodium bisulphite, aqueous	saturated	+	+
Sodium borate		+	+
Sodium bromide oil solution		+	+
Sodium carbonate, aqueous	saturated	+	+
Sodium chlorate, aqueous	saturated	+	+
Sodium chloride, aqueous	saturated	+	+
Sodium chlorite, aqueous	2%	+	+ (176°)

Substance	POLYPROPYLENE		
	Concentration	68°F	140°F
Sodium chlorite, aqueous	5%	+	+
Sodium chlorite, aqueous	10%	(176°) +	+
Sodium chlorite, aqueous	20%	(176°) +	+
Sodium cyanide		+	+
Sodium dichromate		+	+
Sodium ferricyanide		+	+
Sodium ferrocyanide		+	+
Sodium fluoride		+	+
Sodium hydroxide, aqueous	50%	+	+
Sodium hydroxide, aqueous	10%	+	+
Sodium hypochlorite	20%	+	/
Sodium hypochlorite		+	
Sodium nitrate, aqueous		+	+
Sodium nitrite, aqueous		+	+
Sodium silicate		+	+
Sodium sulfate, aqueous	saturated	+	+
Sodium sulfide, aqueous	25%	+	+
Sodium sulfite, aqueous	saturated	+	+
Stannic chloride	saturated	+	+
Stannous chloride	saturated	+	+
Starch		+	+
Sugars and syrups		+	+
Sulfates of [calcium and magnesium]	saturated	+	+
Sulfates of [potassium and sodium]	saturated	+	+
Sulfur		+	+
Sulfuric acid	98% (a)	-	
Sulfuric acid	60%	+	/ (176°)
Sulfuric acid	50%	+	/
Sulfuric acid	10%	+	/
Sulfuric ether		+ to /	/*
Sulfur dioxide, aqueous	all	+	+
Sulfur dioxide, dry and moist	all	+	+
Sulfurous acid		+	+
Sulfur trioxide		-	wet, gas, dry
Sulfuryl chloride		-	
Syrup		+	+
Tallow		+	+
Tannic acid	10%	+	+
Tetrahydrofuran	100%	-	-
Tetralin	100%	-	-
Toluene	100%	-	-
Transformer oil	100%	+	/
Trichloroacetic acid	10%	+	+
Trichloroethylene	100%	+	+
Turpentine	100%	-	-
Urea, aqueous		+	+
Urine		+	+
Vegetable oil		+	+
Water, distilled		+	+
Wet chlorine gas			-
Whiskey		+	+
White paraffin	100%	+	/
White spirit	100%	/	-
Wine		+	+
Xylene	100%	-	-
Yeast		+	+
Zinc chloride	saturated	+	+
Zinc oxide		+	+
Zinc sulphate, aqueous	saturated	+	+

Elastomers

Test Procedure

The criteria for the ratings of various elastomers presented here (Natural Rubber, SBR, and EPDM) were primarily volume swell resistance, compression set resistance, and aging resistance. The ratings were developed from specific data or general agreement of the sources identified in the corresponding table enclosed. Several important factors must be considered in the use of rubber parts in service, including:

1. The Temperature of Service: Greater temperatures increase the effect of all chemicals on polymers. The affect of the temperature varies with the polymer and the chemical.
2. Conditions of Service: A compound that swells badly might still function well as a static seal yet fail in dynamic applications.

Numbers used in the following table:	
<i>Number</i>	<i>Description</i>
1	Minor effect
2	Moderate effect
3	Static only
4	Not recommended
–	Insufficient data

Substance	Natural Rubber (NR, IR)	Styrene Butadiene (SBR, BR)	Ethylene Propylene (EPM, EPDM)
Acetaldehyde	2	3	1
Acetamide	4	4	1
Acetic acid, glacial	2	2	1
Acetic acid 30%	2	2	1
Acetic anhydride	2	2	2
Acetone	3	3	1
Acetophenone	4	4	1
Acetyl chloride	4	4	4
Acetylene	2	2	1
Acrylonitrile	4	4	4
Adipic acid	1	1	1
Alkazene (Dibromoethylbenzene)	4	4	4
Alum-NH3-Cr-K (aq)	1	1	1
Aluminum acetate (aq)	1	2	1
Aluminum chloride (aq)	1	1	1
Aluminum fluoride (aq)	2	1	1
Aluminum nitrate (aq)	1	1	1
Aluminum phosphate (aq)	1	1	1
Aluminum sulfate (aq)	1	1	1
Ammonia anhydrous	4	4	1
Ammonia gas (cold)	1	1	1
Ammonia gas (hot)	4	4	2
Ammonium carbonate (aq)	1	1	–
Ammonium chloride (aq)	1	1	1
Ammonium hydroxide (conc.)	4	4	1
Ammonium nitrate (aq)	3	2	1
Ammonium nitrite (aq)	1	1	1
Ammonium persulfate (aq)	1	4	1
Ammonium phosphate (aq)	1	1	1
Ammonium sulfate (aq)	1	1	1
Amyl acetate (banana oil)	4	4	3
Amyl alcohol	2	2	1
Amyl borate	4	4	4
Amyl chloronaphthalene	4	4	4
Amyl naphthalene	4	4	4
Aniline	4	4	1
Aniline dyes	2	2	1
Aniline hydrochloride	2	4	2
Animal fats	4	4	2
Ansul ether (anesthetics)	4	4	3
Aqua regia	4	4	3
Aroclor, 1248	4	4	3
Aroclor, 1254	4	4	3
Aroclor, 1260	1	1	1
Arsenic acid	2	1	1
Arsenic trichloride (aq)	4	4	3
Askarel	4	4	4
Asphalt	4	4	4
Banana oil (amyl acetate)	4	4	3
Barium chloride (aq)	1	1	1
Barium hydroxide (aq)	1	1	1
Barium sulfate (aq)	1	1	1
Barium sulfide (aq)	1	2	1
Beer	1	1	1
Beet sugar liquors	1	1	1
Benzaldehyde	4	4	1
Benzene	4	4	4
Bezene sulfonic acid	4	4	3
Benzine (Ligroin) (Nitrobenzine) (pet ether)	4	4	4
Benzoic acid	4	4	3
Benzoyl chloride	4	4	4
Benzyl alcohol	4	4	1
Benzyl benzoate	4	4	2
Benzyl chloride	4	4	4
Biphenyl (Diphenyl) (Phenylbenzene)	4	4	4
Blast furnace gas	4	4	4
Bleach solutions	4	4	1
Borax	2	2	1
Bordeaux mixture	2	2	1
Boric acid	1	1	1
Brine	1	1	1
Bromine-anhydrous	4	4	4
Bromine trifluoride	4	4	4
Bromine water	4	4	2
Bromobenzene	4	4	4
Binker oil	4	4	4

Substance	Natural Rubber (NR, IR)	Styrene Butadiene (SBR, BR)	Ethylene Propylene (EPM, EPDM)
Butadiene	4	4	3
Butane	4	4	4
Butter (animal fat)	4	4	1
Butyl acetate	4	4	3
Butyl acetyl ricinoleate	4	4	1
Butyl acrylate	4	4	4
Butyl alcohol	1	1	2
Butyl amine	4	4	2
Butyl benzoate	3	2	2
Butyl carbitol	4	4	1
Butyl cellulosolve	4	4	1
Butyl oleate	4	4	2
Butyl stearate	4	4	3
Butylene	4	4	4
Butyraldehyde	4	4	2
Calcium acetate (aq)	1	4	1
Calcium bisulfite (aq)	4	4	4
Calcium chloride (aq)	1	1	1
Calcium hydroxide (aq)	1	1	1
Calcium hypochlorite (aq)	3	3	1
Calcium nitrate (aq)	1	1	1
Calcium sulfide (aq)	2	2	1
Cane sugar liquors	1	1	1
Carbamate	4	4	2
Carbitol	2	2	2
Carbolic acid (phenol)	4	4	2
Carbon bisulfide	4	4	4
Carbon dioxide	2	2	2
Carbonic acid	1	2	1
Carbon monoxide	2	2	1
Carbon tetrachloride	4	4	4
Castor oil	1	1	2
Cellosolve	4	4	2
Cellosolve acetate	4	4	2
Cellulube (Fryquel)	4	4	1
China wood oil (Tung oil)	4	4	3
Chlorine (dry)	4	4	4
Chlorine (wet)	4	4	3
Chlorine dioxide	4	4	3
Chlorine trifluoride	4	4	4
Chloroacetic acid	4	4	1
Chloroacetone	4	4	1
Chlorobenzene	4	4	4
Chlorobromomethane	4	4	2
Chlorobutadiene	4	4	4
Chlorododecane	4	4	4
Chloroform	4	4	4
O-Chloronaphthalene	4	4	4
1-Chloro-1-Nitro ethane	4	4	4
Chlorosulfonic acid	4	4	4
Chlorotoluene	4	4	4
Chlorox (sodium hypochlorite NaOCl)	4	4	2
Chrome plating solutions	4	4	2
Chromic acid	4	4	3
Citric acid	1	1	1
Coal tar (creosote)	4	4	4
Cobalt chloride (aq)	1	1	1
Coconut oil	4	4	3
Cod liver oil	4	4	1
Coke oven gas	4	4	4
Copper acetate (aq)	1	4	1
Copper chloride (aq)	1	1	1
Copper cyanide (aq)	1	1	1
Copper sulfate (aq)	2	2	1
Cornoil	4	4	3
Cottonseed oil	4	4	2
Creosote (Coal tar)	4	4	4
Cresol	4	4	4
Cresylic acid	4	4	4
Cumene	4	4	4
Cyclohexane	4	4	4
Cyclohexanol	4	4	3
Cyclohexanone	4	4	2
P-Cymene	4	4	4
Decalin	4	4	4
Decane	4	4	4
Denatured alcohol	1	1	1

Substance	Natural Rubber (NR, IR)	Styrene Butadiene (SBR, BR)	Ethylene Propylene (EPM, EPDM)
Detergent solutions	2	2	1
Developing fluids	1	2	2
Diacetone	4	4	1
Diacetone alcohol	4	4	1
Dibenzyl ether	4	4	2
Dibenzyl sebacate	4	4	2
Dibromoethylbenzene (Alkazene)	4	4	4
Dibutyl amine	4	4	3
Dibutyl ether	4	4	3
Dibutyl phthalate	4	4	2
Dibutyl sebecate	4	4	2
O-Dichlorobenzene	4	4	4
Dichloro-isopropyl ether	4	4	3
Dicyclohexylamine	4	4	4
Diesel oil	4	4	4
Diethylamine	2	2	2
Diethyl benzene	4	4	4
Diethyl ether	4	4	4
Diethylene glycol	1	1	1
Diethyl sebacate	4	4	2
Diisobutylene	4	4	4
Diisopropyl benzene	4	4	4
Diisopropyl ketone	4	4	1
Diisopropylidene acetone (Phorone)	4	4	3
Dimethyl aniline (Xylidene)	3	3	2
Dimethyl ether (methyl ether) (monomethyl ether)	4	4	4
Dimethyl formamide	4	4	2
Dimethyl phthalate	4	4	2
Dinitrotoluene	4	4	4
Dioctyl Phthalate	4	4	2
Dioctyl Sebecate	4	4	2
Dioxane	4	4	2
Dioxolane	4	4	2
Dipentene	4	4	4
Diphenyl (Biphenyl) (Phenylbenzene)	4	4	4
Diphenyl oxides	4	4	4
Dowtherm oil	4	4	4
Dry cleaning fluids	4	4	4
Epichlorohydrin	4	4	2
Ethane	4	4	4
Ethanolamine	2	2	2
Ethyl acetate	4	4	2
Ethyl acetoacetate	3	3	2
Ethyl acrylate	4	4	2
Ethyl alcohol	1	1	1
Ethyl benzene	4	4	4
Ethyl benzoate	1	1	1
Ethyl cellosolve	4	4	4
Ethyl cellulose	2	2	2
Ethyl chloride	4	4	3
Ethyl chlorocarbonate	4	4	2
Ethyl chloroformate	4	4	2
Ethyl ether	4	4	3
Ethyl formate	4	4	2
Ethyl mercaptan	4	4	3
Ethyl oxalate	1	1	1
Ethyl pentachlorobenzene	4	4	4
Ethyl silicate	2	2	1
Ethylene	3	3	2
Ethylene chloride	4	4	3
Ethylene chlorohydrin	2	2	2
Ethylene diamine	1	2	1
Ethylene dichloride	4	4	3
Ethylene glycol	1	1	1
Ethylene oxide	4	4	3
Ethylene trichloride	4	4	3
Fatty acids	4	4	3
Ferric chloride (aq)	1	1	1
Ferric nitrate (aq)	1	1	1
Ferric sulfate (aq)	1	1	1
Fishoil	4	4	4
Fluorinated cyclic ethers	4	4	1
Fluorine (liquid)	4	4	4
Fluorobenzene	4	4	4
Fluoroboric acid	1	1	1

Substance	Natural Rubber (NR, IR)	Styrene Butadiene (SBR, BR)	Ethylene Propylene (EPM, EPDM)
Fluorocarbon oils	2	2	1
Fluorolube	2	3	1
Fluorosilicic acid (hydrofluosilicic acid)	2	3	2
Formaldehyde (RT)	2	2	1
Formic acid	2	1	1
Freon 11	4	4	4
Freon 12	2	1	2
Freon 13	1	1	1
Freon 21	4	4	4
Freon 22	2	1	1
Freon 31	2	2	1
Freon 32	1	1	1
Freon 112	4	3	4
Freon 113	3	2	3
Freon 114	1	1	1
Freon 115	1	1	1
Freon 142b	2	2	2
Freon 152a	1	1	1
Freon 218	1	1	1
Freon C316	1	1	1
Freon C318	1	1	1
Freon 13B1	1	1	1
Freon 114B2	4	3	4
Freon 502	1	1	1
Freon TF	4	3	4
Freon T-WD602	4	3	2
Freon TMC	4	4	3
Freon T-P35	1	1	1
Freon TA	3	3	2
Freon TC	4	3	2
Freon MF	4	4	4
Freon BF	4	4	4
Fueloil	4	4	4
Fumaric acid	3	3	2
Furan, furfuran	4	4	3
Furfural	4	4	2
Fyrquel (cellulube)	4	4	1
Gallic acid	1	2	2
Gasoline	4	4	4
Gelatin	1	1	1
Glouber's salt (aq)	2	4	2
Glucose	1	1	1
Glue	2	2	1
Glycerin	1	1	1
Glycols	1	1	1
Green sulfate liquor	2	2	1
Holowax oil	4	4	4
N-Hexaldehyde	4	4	1
Hexane	4	4	4
N-Hexene-1	4	4	4
Hexyl alcohol	2	2	3
Hydrazine	1	1	1
Hydraulic oil (petroleum)	4	4	4
Hydrobromic acid	1	4	1
Hydrobromic acid 40%	1	4	1
Hydrochloric acid (cold) 37%	2	2	1
Hydrochloric acid (hot) 37%	4	4	3
Hydrocyanic acid	2	2	1
Hydrofluoric acid (conc.) cold	4	4	3
Hydrofluoric acid (conc.) hot	4	4	4
Hydrofluoric acid - anhydrous	4	4	3
Hydrofluosilicic acid (fluosilicic acid)	2	3	2
Hydrogen gas	2	1	1
Hydrogen peroxide (90%)	4	4	2
Hydrogen sulfide (wet) cold	4	4	1
Hydrogen sulfide (wet) hot	4	4	1
Hydroquinone	2	4	2
Hypochlorous acid	2	4	2
Iodine pentafluoride	4	4	4
Iodoform	4	4	4
Isobutyl alcohol	1	2	1
Isooctane	4	4	4
Isophorone	4	4	3
Isopropyl acetate	4	4	2
Isopropyl alcohol	1	2	1
Isopropyl chloride	4	4	4

Substance	Natural Rubber (NR, IR)	Styrene Butadiene (SBR, BR)	Ethylene Propylene (EPM, EPDM)
Isopropyl ether	4	4	4
Kerosene	4	4	4
Lacquers	4	4	4
Lacquer solvents	4	4	4
Lactic acid (cold)	1	1	1
Lactic acid (hot)	4	4	4
Lard	4	4	2
Lavender oil	4	4	4
Lead acetate (aq)	1	4	1
Lead nitrate (aq)	1	1	1
Lead sulfamate (aq)	2	2	1
Ligroin (Benzine) (Nitrobenzine) (pet ether)	4	4	4
Lime bleach	1	2	1
Lime sulfur	4	4	1
Lindol (hydraulic fluid)	4	4	1
Linoleic acid	4	4	4
Linseed oil	4	4	3
Liquefied petroleum gas	4	4	4
Lubricating oils (petroleum)	4	4	4
Lye2	2	1	-
Magnesium chloride (aq)	1	1	1
Magnesium hydroxide (aq)	2	2	1
Magnesium sulfate (aq)	2	2	1
Maleic acid	3	3	2
Maleic anhydride	3	3	2
Malic acid	3	3	2
Mercury chloride (aq)	1	1	1
Mercury	1	1	1
Mesityl oxide	4	4	2
Methane	4	4	4
Methyl acetate	3	3	1
Methyl acrylate	4	4	2
Methylacrylic acid	4	4	2
Methyl alcohol	1	1	1
Methyl bromide	4	4	4
Methyl butyl ketone (propyl acetone)	4	4	1
Methyl cellosolve	4	4	2
Methyl chloride	4	4	3
Methyl cyclopentane	4	4	4
Methylene chloride	4	4	3
Methyl ether (dimethyl ether) (monomethyl ether)	4	4	4
Methyl ethyl ketone	4	4	1
Methyl formate	4	4	2
Methyl isobutyl ketone	4	4	2
Methyl methacrylate	4	4	3
Methyl oleate	4	4	2
Methyl salicylate	3	3	2
Milk	1	1	1
Mineral oil	4	4	3
Monochlorobenzene	4	4	4
Monomethyl aniline	4	4	2
Monoethanol amine	2	2	1
Monomethyl ether (methyl ether) (dimethyl ether)	4	4	4
Monovinyl acetylene	2	2	2
Mustard gas	1	2	1
Naphtha	4	4	4
Naphthalene	4	4	4
Naphthalenic acid	4	4	4
Natural gas	2	2	4
Neats foot oil	4	4	2
Neville acid	4	4	2
Nickel acetate (aq)	1	4	1
Nickel chloride (aq)	1	1	1
Nickel sulfate (aq)	2	2	1
Niter cake	1	1	1
Nitric acid (conc.)	4	4	4
Nitric acid (dilute)	4	4	2
Nitric acid - red fuming	4	4	4
Nitrobenzene	4	4	1
Nitrobenzene (petroleum ether)	4	4	4
Nitroethane	2	2	2
Nitrogen	1	1	1
Nitrogen tetroxide	4	4	3
Nitromethane	2	2	2
Octachlorotoluene	4	4	4

Substance	Natural Rubber (NR, IR)	Styrene Butadiene (SBR, BR)	Ethylene Propylene (EPM, EPDM)
Octadecane	4	4	4
N-Octane	4	4	4
Octyl alcohol	2	2	3
Oleic acid	4	4	4
Oleum spirits	4	4	4
Olive oil	4	4	2
O-Dichlorobenzene	4	4	4
Oxalic acid	2	2	1
Oxygen - cold	2	2	1
Oxygen - (200°-400°F)	4	4	3
Ozone	4	4	1
Paint thinner, duco	4	4	4
Palmitic acid	2	2	2
Peanut oil	4	4	3
Perchloric acid	4	4	2
Perchloroethylene	4	4	4
Petroleum - below 250°F	4	4	4
Petroleum - above 250°F	4	4	4
Phenol (carbolic acid)	4	-	2
Phenylbenzene (biphenyl) (diphenyl)	4	4	4
Phenyl ethyl ether	4	4	4
Phenyl hydrazine	1	2	2
Phorane (diisopropylidene acetone)	4	4	3
Phosphoric acid - 20%	2	2	1
Phosphoric acid - 45%	3	3	1
Phosphorus trichloride	4	4	1
Pickling solution	4	4	3
Picric acid	2	2	2
Pinene	4	4	4
Pineoil	4	4	4
Piperidine	4	4	4
Plating solution - chrome	4	4	1
Polyvinyl acetate emulsion	2	4	1
Potassium acetate (aq)	1	4	1
Potassium chloride (aq)	1	1	1
Potassium cupro cyanide (aq)	1	1	1
Potassium cyanide (aq)	1	1	1
Potassium dichromate (aq)	2	2	1
Potassium hydroxide (aq)	2	2	1
Potassium nitrate (aq)	1	1	1
Potassium sulfate (aq)	2	1	1
Producer gas	4	4	4
Propane	4	4	4
i-Propyl acetate	4	4	2
n-Propyl acetate	4	4	2
Propyl acetone (methyl butyl ketone)	4	4	1
Propyl alcohol	1	1	1
Propyl nitrate	4	4	2
Propylene	4	4	4
Propylene oxide	4	4	2
Pydraul, 10E, 29 ELT	4	4	1
Pydraul, 30E, 50E, 65E, 90E	4	4	1
Pydraul, 115E	4	4	1
Pydraul, 230E, 312C, 540C	4	4	4
Pyranol, transformer oil	4	4	4
Pyridine	4	4	2
Pyroigneous acid	4	4	2
Pyrrrole	3	3	3
Radiation	3	3	2
Rapeseed oil	4	4	1
Red oil (MIL-H-5606)	4	4	4
RJ-1 (MIL-F-25558 B)	4	4	4
RP-1 (MIL-F-25576 C)	4	4	4
Sal ammoniac	1	1	1
Salicylic acid	1	2	1
Salt water	1	1	1
Sewage	2	2	2
Silicate esters	4	4	4
Silicone greases	1	1	1
Silicone oils	1	1	1
Silver nitrate	1	1	1
Skydrol 55	4	4	1
Skydrol 7000	4	4	1
Soap solutions	2	1	1
Soda ash	1	1	1
Sodium acetate (aq)	1	4	1

Substance	Natural Rubber (NR, IR)	Styrene Butadiene (SBR, BR)	Ethylene Propylene (EPM, EPDM)
Sodium bicarbonate (aq) (baking soda)	1	1	1
Sodium bisulfite (aq)	1	2	1
Sodium borate (aq)	1	1	1
Sodium chloride (aq)	1	1	1
Sodium cyanide (aq)	1	1	1
Sodium hydroxide (aq)	1	1	1
Sodium hypochlorite (aq) (Clorox)	4	4	2
Sodium metaphosphate (aq)	1	1	1
Sodium nitrate (aq)	2	1	1
Sodium perborate (aq)	2	2	1
Sodium peroxide (aq)	2	2	1
Sodium phosphate (aq)	1	1	1
Sodium silicate (aq)	1	1	1
Sodium sulfate (aq)	2	2	1
Sodium thiosulfate (aq)	2	2	1
Soybean oil	4	4	3
Stannic chloride (aq)	1	1	1
Stannous chloride (aq)	1	1	1
Steam under 300°F	4	4	1
Steam over 300°F	4	4	3
Stearic acid	2	2	2
Stoddard solvent	4	4	4
Styrene	4	4	4
Sucrose solution	1	1	1
Sulfite liquors	2	2	2
Sulfur	4	4	1
Sulfur chloride (aq)	4	4	4
Sulfur dioxide (dry)	2	2	1
Sulfur dioxide (wet)	4	4	1
Sulfur dioxide (liquified under pressure)	4	4	1
Sulfur hexafluoride	4	4	1
Sulfur trioxide	2	2	2
Sulfuric acid (dilute)	3	3	2
Sulfuric acid (conc.)	4	4	3
Sulfuric acid (20% oleum)	4	4	4
Sulfurous acid	2	2	2
Tannic acid	1	2	1
Tar, bituminous	4	4	3
Tartaric acid	3	4	2
Terpineol	4	4	3
Tertiary butyl alcohol	2	2	2
Tertiary butyl catechol	4	2	2
Tertiary butyl mercaptan	4	4	4
Tetrabromoethane	4	4	4
Tetrabromomethane	4	4	4
Tetrabutyl titanate	2	2	1
Tetrachloroethylene	4	4	4
Tetraethyl lead	4	4	4
Tetrahydrofuran	4	4	3
Tetralin	4	4	4
Thionyl chloride	4	4	3
Titanium tetrachloride	4	4	4
Toluene	4	4	4
Toluene diisocyanate	4	4	2
Transformer oil	4	4	4
Transmission fluid type A	4	4	4
Triacetin	2	2	1
Triaryl phosphate	4	4	1
Tributoxy ethyl phosphate	2	2	1
Tributyl mercaptan	4	4	4
Tributyl phosphate	2	4	2
Trichloroacetic acid	3	2	2
Trichloroethane	4	4	4
Trichlorethylene	4	4	4
Tricresyl phosphate	4	1	4
Triethanol amine	2	2	1
Triethyl aluminum	4	4	3
Triethyl borane	4	4	3
Trinitrotoluene	4	4	4
Triocetyl phosphate	4	4	1
Tung oil (China wood oil)	4	4	3
Turbine oil	4	4	4
Turpentine	4	4	4
Unsymmetrical dimethyl hydrazine (UDMH)	1	1	1
Varnish	4	4	4

Substance	Natural Rubber (NR, IR)	Styrene Butadiene (SBR, BR)	Ethylene Propylene (EPM, EPDM)
Vegetable oils	4	4	3
Versilube F-50	1	1	1
Vinegar	2	2	1
Vinyl chloride	4	4	4
Wagner 21B brake fluid	2	1	1
Water	1	1	1
Whiskey, wines	1	1	1
White pine oil	4	4	4
White oil	4	4	4
Woodoil	4	4	4
Xylene	4	4	4
Xylidine (Di-methyl aniline)	3	3	2
Zeolites	1	1	1
Zinc acetate (aq)	1	4	1
Zinc chloride (aq)	1	1	1
Zinc sulfate (aq)	2	2	1
TT-T-656b	4	4	1
VV-B-680	2	1	1
VV-G-632	4	4	4
VV-G-671c	4	4	4
VV-H-910	2	1	1
VV-I-530a	4	4	4
VV-K-211d	4	4	4
VV-K-220a	4	4	4
VV-L-751b	4	4	4
VV-L-800	4	4	4
VV-L-820b	4	4	4
VV-L-825a type I	4	4	4
VV-L-825a type II	4	4	4
VV-L-825a type III	4	4	4
VV-O-526	4	4	4
VV-P-216a	4	4	4
VV-P-236	4	4	4
51-F-23	4	4	4
ASTM Method D-471			
1	4	4	4
2	4	4	4
3	4	4	4
MIL-L-644 B	3	3	3
MIL-L-2104 B	4	4	4
MIL-L-2105 B	4	4	4
MIL-G-2108	4	4	4
MIL-S-3136 B type I	4	4	4
MIL-S-3136 B type II	4	4	4
MIL-S-3136 B type III	4	4	4
MIL-S-3136 B type IV	4	4	4
MIL-S-3136 B type V	4	4	4
MIL-S-3136 B type VI	4	4	4
MIL-S-3136 B type VII	4	4	4
MIL-L-3150 A	4	4	4
MIL-L-3503	4	4	4
MIL-L-3545 B	4	4	4
MIL-C-4339 C	4	4	4
MIL-G-4343 B	4	4	3
MIL-L-5020 A	4	4	4
MIL-J-5161 F	4	4	4
MIL-C-5545 A	4	4	4
MIL-H-5559 A	2	1	1
MIL-F-5566	1	1	1
MIL-F-5602	4	4	4
MIL-H-5606 B (red oil)	4	4	4
MIL-J-5624 G JP-3, JP-4, JP-5	4	4	4
MIL-O-6081 C	4	4	4
MIL-L-6082 C	4	4	4
MIL-H-6083 C	4	4	4
MIL-L-6085 A	4	4	4
MIL-L-6086 B	4	4	4
MIL-L-6387 A	4	4	4
MIL-C-6529 C	4	4	4
MIL-F-7024 A	4	4	4
MIL-H-7083 A	2	1	1
MIL-G-7118 A	4	4	4
MIL-G-7187	4	4	4
MIL-G-7421 A	4	4	4
MIL-H-7644	2	1	1
MIL-L-7645	4	4	4
MIL-G-7711 A	4	4	4
MIL-L-7808 F	4	4	4
MIL-L-7870 A	4	4	4

Substance	Natural Rubber (NR, IR)	Styrene Butadiene (SBR, BR)	Ethylene Propylene (EPM, EPDM)
MIL-C-8188 C	4	4	4
MIL-A-8243 B	2	1	1
MIL-L-8383 B	4	4	4
MIL-H-8446 B (MLO-8515)	4	4	4
MIL-L-8660 B	1	1	1
MIL-L-9000 F	4	4	4
MIL-T-9188 B	4	4	1
MIL-L-9236 B	3	3	3
MIL-L-10295 A	4	4	4
MIL-L-10324 A	4	4	4
MIL-G-10294 B	4	4	4
MIL-L-11734 B	4	4	4
MIL-O-11773 B	4	4	4
MIL-P-12098	2	1	1
MIL-H-13862	4	4	4
MIL-H-13866 A	4	4	4
MIL-H-13910 B	2	1	1
MIL-H-13919 A	4	4	4
MIL-L-14107 B	4	4	4
MIL-L-15017	4	4	4
MIL-L-15015 B	4	4	4
MIL-L-15019 C	4	4	4
MIL-L-15719 A	3	2	2
MIL-G-15793	4	4	4
MIL-F-16929 A	4	4	4
MIL-L-16958 A	4	4	4
MIL-F-17111	4	4	4
MIL-L-17331 D	4	4	4
MIL-L-17353 A	4	4	4
MIL-L-17672 B	4	4	4
MIL-L-18486 A	4	4	4
MIL-G-18709 A	4	4	4
MIL-H-19457 B	4	4	1
MIL-F-19605	4	4	4
MIL-L-19701	4	4	4
MIL-21260	4	4	4
MIL-S-21568 A	2	1	1
MIL-H-22072	2	1	1
MIL-L-22396	4	4	4
MIL-L-23699 A	4	4	4
MIL-G-23827 A	4	4	4

Substance	Natural Rubber (NR, IR)	Styrene Butadiene (SBR, BR)	Ethylene Propylene (EPM, EPDM)
MIL-G-25013 D	2	1	1
MIL-F-25172	4	4	4
MIL-L-25336 B	4	4	4
MIL-F-25524 A	4	4	4
MIL-G-25537 A	4	4	4
MIL-F-25558 B (RJ-1)	4	4	4
MIL-F-25576 C (RP-1)	4	4	4
MIL-H-25598	4	4	4
MIL-F-25656 B	4	4	4
MIL-L-25681 C	2	1	1
MIL-G-25760 A	3	3	4
MIL-L-25968	4	4	4
MIL-L-26087 A	4	4	4
MIL-G-27343	1	1	1
MIL-H-27601 A	4	4	4
MIL-G-27617	-	2	1
MIL-I-27686 D	2	1	1
MIL-L-27694 A	1	1	1
MIL-L-46000 A	4	4	4
MIL-H-46001 A	4	4	4
MIL-L-46002	4	4	4
MIL-L-46004	4	4	4
MIL-P-46046 A	2	1	1
MIL-H-81019 B	4	4	4
MIL-S-81087	1	1	1
O-A-548 a	2	1	1
O-T-634 b	4	4	4
P-S-661 b	4	4	4
P-D-680	4	4	4
TT-N-95 a	4	4	4
TT-N-97 b	4	4	4
TT-I-735 b	1	1	1
TT-S-735 type I	4	4	4
TT-S-735 type II	4	4	4
TT-S-735 type III	4	4	4
TT-S-735 type IV	4	4	4
TT-S-735 type V	4	4	4
TT-S-735 type VI	4	4	4
TT-S-735 type VI	4	4	4

Technical Resources

1. LyondellBasell. (August 2002). *Pro-fax and Moplen Polypropylene Chemical Resistance*. Product Brochure.
2. Dynalab Corp. (19 August 2009). *Plastic Properties Technical Information* [On-line]. Available: http://www.dynalabcorp.com/technical_info_plastic_properties.asp
3. Baxter Rubber Company (19 August 2009). *Chemical Resistance Guide* [On-line]. Available: <http://www.baxterrubber.com/resistance.html>



Technical Note

TN 4.03 Abrasion Resistance of Polypropylene

Introduction

With the introduction of ADS High Performance (HP) polypropylene (PP) pipe for the storm drainage and sanitary sewer markets, it is necessary for designers to have confidence in polypropylene's expected performance in conditions where the effluent may carry debris or abrasive materials. To address designer's concerns, a comparative evaluation of whether polypropylene had similar abrasion resistance to high density polyethylene (HDPE) was undertaken. While it was initially hypothesized that polypropylene would have comparable, if not better, abrasion resistance, testing verification is essential. If it could be established that polypropylene and HDPE have similar resistance to abrasion, the more extensive history and test data for HDPE could be applied to polypropylene insofar that polypropylene would behave similarly to HDPE in abrasive environments. To test this hypothesis, two types of tests were conducted. The first test used Taber® abrading wheels directly on a sample of thermoplastic material. The second test, in order to more closely mimic drainage and sewer conditions, involved placing thermoplastic samples in water flow carrying abrasive sand. Both tests measured the mass loss over time and provide a direct comparison between the two materials.

Taber Abrasion Test

In April 2009, Polymer Diagnostics, Inc. conducted Taber abrasion testing on polypropylene, HDPE and PVC material samples in accordance with ASTM D3389 in order to determine the material's mass loss under direct abrasion. Although this test does not simulate pipe carrying effluent, the test still provides a standardized method for comparing the abrasion resistance, or hardness, of different materials.

Test Setup

Each material sample was mounted on a Taber Abrader Model 5130 where the sample is subjected to rub-wear action of an abrading wheel. An abrasion pattern of crossed arcs simulates abrasion of the material from all angles. Directly abrading material in this manner allows for quick results through accelerated testing in order to simulate long-term use, which may otherwise take years to compile.

The initial mass of each sample was recorded to determine the total mass loss of the respective material over the duration of the test. All samples were tested using a CS-10 abrasion wheel with 250 grams of force. The total test time was 40 hrs, allowing for 500 revolutions of the abrading wheel.

Results

Results in Table 1 indicate a greater mass loss of the PVC samples compared to both the polypropylene and HDPE samples. The mass loss of the HDPE sample was slightly higher than the polypropylene sample, but the proximity of values allows for the conclusion that both samples performed similarly. These results indicate a similarity between polypropylene and HDPE materials as it relates to material hardness. The final mass loss of PVC was 5 to 8 times that of polypropylene.

Table 1
Taber Abrasion Test Results for Material Mass Loss

Material	Start Mass (g)	End Mass (g)	Total Mass Loss (mg)
PP #1	30.6036	30.6034	0.2
PP #2	30.6868	30.6866	0.2
HDPE, 5% Carbon Black	31.6658	31.6655	0.3
PVC – white	50.8776	50.8759	1.7
PVC – gray	50.4187	50.4176	1.1

Abrasion Resistance in Water Flow

While a direct correlation between polypropylene and HDPE materials' abrasion resistance is supported by the Taber abrasion test results, a second test was conducted to confirm those results and simulate the abrasion resistance of a pipe's invert when carrying effluent with suspended abrasives.

ADS Facility Testing

First, material plaques of both polypropylene and HDPE were cut and weighed to determine the initial mass of the sample. The samples were then scanned into AutoCAD in order to precisely measure the surface area that will be abraded. Additionally, each sample was inspected for any signs of abnormality including splitting, cracking, material thinning, etc. No abnormalities were noted and product was considered to be in good condition.

Next, a closed-loop test system was constructed in order to achieve a controlled flow rate over the samples. A constant hydraulic loading was established in the system, which consisted of a 2" grinder pump, 18" trough and a collection basin as shown in Figure 1. OK-110 sand was added to the water flow so a relatively heavy sand loading was obtained. The grinder pump, in conjunction with a mixing tee, was used to ensure the sand stayed in a suspended state in the mixture. The flow rate of sand/water mixture over the plaques was 3 ft/sec.

In the trough, four sample plaques, two of polypropylene and two of HDPE, were placed at the bottom of the trough in the flow path, shown in Figure 2. With the exception of removing the samples for weighing, the test unit allowed for continuous subjection of the samples to the slurry mixture.

Figure 1
Close-Loop Test System



Figure 2
Plaques in the Test System



Results

It was noted during visual inspections of the samples throughout the test that minor scouring of the samples was occurring. These observations affirmed that the test was successful in creating the desired abrasive conditions for sample analysis. Comparing results in Table 2 of the mass and thickness loss, polypropylene performed slightly better than HDPE. The second sample of HDPE was removed from testing as it was damaged during detachment operations for periodic examinations; subsequently resulting in a large loss of material not related to the abrasion testing. Even so, results for both HDPE samples indicate a higher material loss value compared to the polypropylene sample results. Ultimately, these results favor polypropylene over HDPE for constant flow applications where the effluent carries a high bed load.

Table 2
Material Loss Results

	Initial Weight (g)	Final Weight (g)	Time (hrs)	Loss (g/hr)	Surface Area (in ²)	Loss (mils/yr)
PP large sample	221.5	221.5	4029	0.00000	110.34	0.00
PP small sample	27.101	27.099	3483	0.00001	15.43	0.02
HDPE large sample	141	140.75	4029	0.00006	89.47	0.39
HDPE small sample	Damaged during examination					

Conclusions

Both tests indicate high abrasion resistance of polypropylene material. The Taber test indicated that polypropylene and HDPE behaved almost identical to direct rub-wear abrasion, and significantly better compared to PVC material. The test simulating abrasive water flow reaffirmed the Taber test results and indicated that polypropylene performs similarly or slightly better than HDPE. From these results it is reasonable to conclude that other abrasion resistance tests using HDPE samples are also representative of polypropylene material. With this relationship in mind, the tests outlined in the Drainage Handbook *Durability* section that are specific to HDPE and establish the material's superior resistance to abrasion compared to other pipe materials also support the argument for polypropylene's superior abrasion resistance



Technical Note

TN 5.01 Recommended Use for Trench Boxes

Introduction

Trench boxes provide a safer work area to install pipe in deep trenches, restricted right-of-ways, or in soils that have insufficient stability. This technical bulletin provides guidelines on how to maximize the structural stability and alignment of the ADS pipe system while using a trench box. While these guidelines will work for most cohesive and noncohesive native soils, highly unusual soil conditions may require further investigation or different techniques.

General Considerations

OSHA regulations should be carefully followed for all aspects of pipe installation, including those that involve trench boxes. If information contained in this document conflicts in any way with OSHA or other safety regulations, those requirements must take precedence.

Some installations may not require trench boxes if the trench sidewall can be sloped adequately. The design engineer should provide specific guidance on acceptable slopes, but in no case should the trench wall slope be greater than the angle of repose of the native soil.

The length of the trench box should be suitable for the pipe length. Standard length for ADS N-12® IB is 19.7 ft (6m) although it may be possible to supply shorter lengths for use in shorter trench boxes.

Subtrench Installations

The most effective way to maintain a sound system is to provide a 'subtrench' within which to place the pipe and backfill. The bottom of the trench box should be placed no more than 24" from the bottom of the work surface, in accordance with OSHA regulation 1926.652(g)(2). This may require the trench box be raised during pipe installation to conform with both OSHA requirements and to properly backfill and compact the soil around the pipe. Backfill and compact according to the design specifications within the subtrench. When possible, without disturbing the pipe or backfill, the trench box can be pulled along the top edge of the subtrench. In some cases, it may be necessary to move the trench box multiple times to obtain the required compaction of the material in the soil envelope. In either case, it is paramount to achieve the necessary backfill placement and compaction for a quality installation. Refer to Figure 1 for a typical sub trench installation.

Figure 1
Subtrench Installation

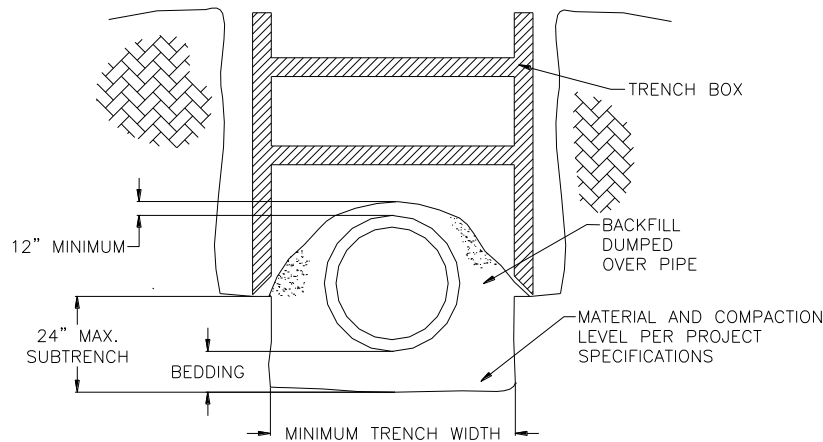

Subtrench installations also make it easier to use a geotextile around the backfill if it is required by the project specifications. Line the subtrench with the geotextile, place the pipe and backfill over the geotextile, and wrap the geotextile over the top of the pipe/backfill system.

Regular Trench Installations

In installations not involving a subtrench situation, dragging a trench box should only be done if it does not damage the pipe or disrupt the backfill; otherwise, the box should be lifted vertically into its new position. If it is necessary for a trench box to be dragged through a trench, do not raise the box more than 24" above the work surface.

Another alternative for when the box will be dragged is to use a well-graded granular backfill material at least two diameters on either side of the pipe and compact it to a minimum of 90% standard Proctor density before moving the box. After the trench box is moved, immediately fill the area between the pipe/backfill structure and the trench wall with a granular material.

If the project requires a geotextile around the backfill, use a well-graded granular backfill material and compact it to at least 90% standard Proctor density. Do not drag the box; instead, lift it vertically. After the trench box is removed, immediately fill the area between the pipe/backfill structure and the trench wall with a granular material and compact according to project requirements. The geotextile manufacturer may be able to provide additional information regarding the suitability of specific geotextiles for use with trench boxes.

Summary

While trench boxes increase worker safety in difficult site conditions, their use requires some precautions be taken to ensure a structurally sound finished installation.

Construction of a subtrench is the most effective means of maintaining a sound system; the trench box can simply be pulled along the top edge of the subtrench. When a regular trench is used, techniques such as lifting the box, keeping the box about three-fourths the nominal pipe diameter up from the trench bottom, and providing a wide granular backfill envelope will help provide a quality installation.



Technical Note

TN 5.02 Flowable Fill Backfill for Thermoplastic Pipe

Introduction

The use of flowable fill, also known as controlled low strength material (CLSM), controlled density fill (CDF), and slurry fill, as pipe bedding and backfill material has steadily been increasing. The term “flowable fill” encompasses a variety of fill materials that are used as alternates to compacted granular fill. The materials are comprised of mixtures of sand, Portland cement, Class C or Class F fly ash, and water. In addition, the mix is typically flowable and self-leveling at the time of placement.

Flowable fill is an alternative to conventional soil or stone backfill and has been used for unique applications and installations of pipe for some time. It has the advantage of providing adequate strength quickly, while providing an easy and efficient placement system. Flowable fill has proven to be a viable alternative when stone, sand, or other backfills have limited availability or cost prohibits their use. Even with these advantages it is necessary that the fill be controlled and care taken to provide for the proper installation.

Use of Flowable Fill

The following provides some advantages and disadvantages when deciding whether flowable fill should be specified or recommended on a project.

Advantages

- Allows for narrower trench and less disturbance to the native material.
- Eliminates the need for backfill compaction.
- Ensured proper distribution of support around the pipe.
- Reduces the amount of material excavated on a project.
- Time, personnel and equipment required to install flowable fill are typically less than that required for proper placement and compaction of conventional backfill materials, particularly fine-grained soils.
- Flowable fill may be made on-site using native soil as part of the mix where sands or silty sands exist.
- Time and equipment required for compressive strength testing is often less than that required to test soil compaction.



Disadvantages

- More costly than granular backfill due to the many components required and specialized delivery.
- Improper mix components can cause difficult future excavation if taps or extensions are required.
- Cannot be stockpiled on site like granular backfill. Time saved during the placement of the flowable fill can be wasted waiting on ready-mix delivery.
- Unless precaution is taken, the potential for pipe flotation is high during the installation process.

Mix Design

The mix design of flowable fill can vary widely. The flowable fill mix should be designed to meet all strength and flowability requirements. A suggested strength ranges between 50 psi and 100 psi for the 28 day strength; mixes that have 28-day compressive strengths greater than 100 psi should be avoided due to increased difficulty in future excavation, if needed. The flowable fill should be able to flow into all voids between the pipe and the trench walls. The mix design should be laboratory tested prior to installation ensure that the proper results are obtained during field batching. The field mix may also require monitoring and adjustments to maintain the proper mix and properties. These variations in the field mix can be due to many factors including water content, temperature and humidity during placement.

Installation Considerations

Environment

Flowable fill cannot be used in all temperature and weather conditions. It is recommended that the temperature be at least 40°F and that the soil exposed to the flowable fill be unfrozen. There should be no appreciable precipitation during placement to initial set. Flowable fill should be protected from freezing temperatures.

Joints

For flowable fill applications, the use of a watertight joint is recommended. For soiltight joints, precautionary measures should be taken to prevent infiltration of flowable fill mix material. This will depend nearly entirely on the consistency of the mix design.

Placement of Flowable Fill

Trench excavation should follow normal procedures and meet all OSHA safety regulations. Trench width will be dictated by the native material strength. When acceptable in-situ material exists in the trench, like rock or other high-bearing soils, the trench widths may be reduced to within 6-in along each side of the pipe, provided there is enough space to properly place the flowable fill in the pipe haunch areas. Table 1 depicts typical trench widths for a flowable fill installation. Once the trench is excavated to the proper line and grade, placement of pipe may begin. The pipe should be laid in the trench and joined in accordance with publish recommended installation guidelines.

Table 1
Recommended Trench Widths for Flowable Fill Backfill

Nominal Pipe Diam, in. (mm)	Minimum Trench in. (m)	Nominal Pipe Diam, in. (mm)	Minimum Trench in. (m)
12 (300)	22 (0.6)	36 (900)	59 (1.5)
15 (375)	27 (0.7)	42 (1050)	66 (1.7)
18 (450)	33 (0.8)	48 (1200)	74 (1.9)
24 (600)	42 (1.0)	54 (1350)	82 (2.0)
30 (750)	51 (1.3)	60 (1500)	90 (2.3)

*AASHTO LRFD Section C12.6.6.1, 2006

It is recommended that both an anchoring system and incremental lifts be utilized during installation. Refer to Figure 1 below for lift recommendations and corresponding recommended anchoring forces. Keep in mind that the fill should be brought up evenly on both sides to prevent unbalanced forces from acting on the pipe. Each lift should be allowed to reach initial set, prior to placing the next lift. Time to initial set is dependent on the mix design as well as ambient temperature and moisture. The mix supplier should be contacted to determine the site-specific waiting period recommended between lifts. NOTE: The use of plasticizers or other admixtures can greatly affect cure time and final compressive strength. While it is recommended to place the flowable fill in incremental lifts, it should be noted, one continuous lift may be used provided flotation restraints have been properly designed and installed, see Table 2 for recommendations.

If additional backfill is to be placed over the flowable fill to reach final grade, it should not be placed until the flowable fill has reached a minimum compressive strength, as determined by the design engineer. If minimum strength is not specified or time constraints do not allow for testing of cylinders, ASTM C403 and ASTM D6024 can be referenced to determine if flowable fill has gained adequate strength.

Since moisture is beneficial to curing it may be desirable to place a thin layer of soil (6 inches) on top of the flowable fill section for enhanced curing.

Figure 1
Hold Down Force for Incremental Lifts

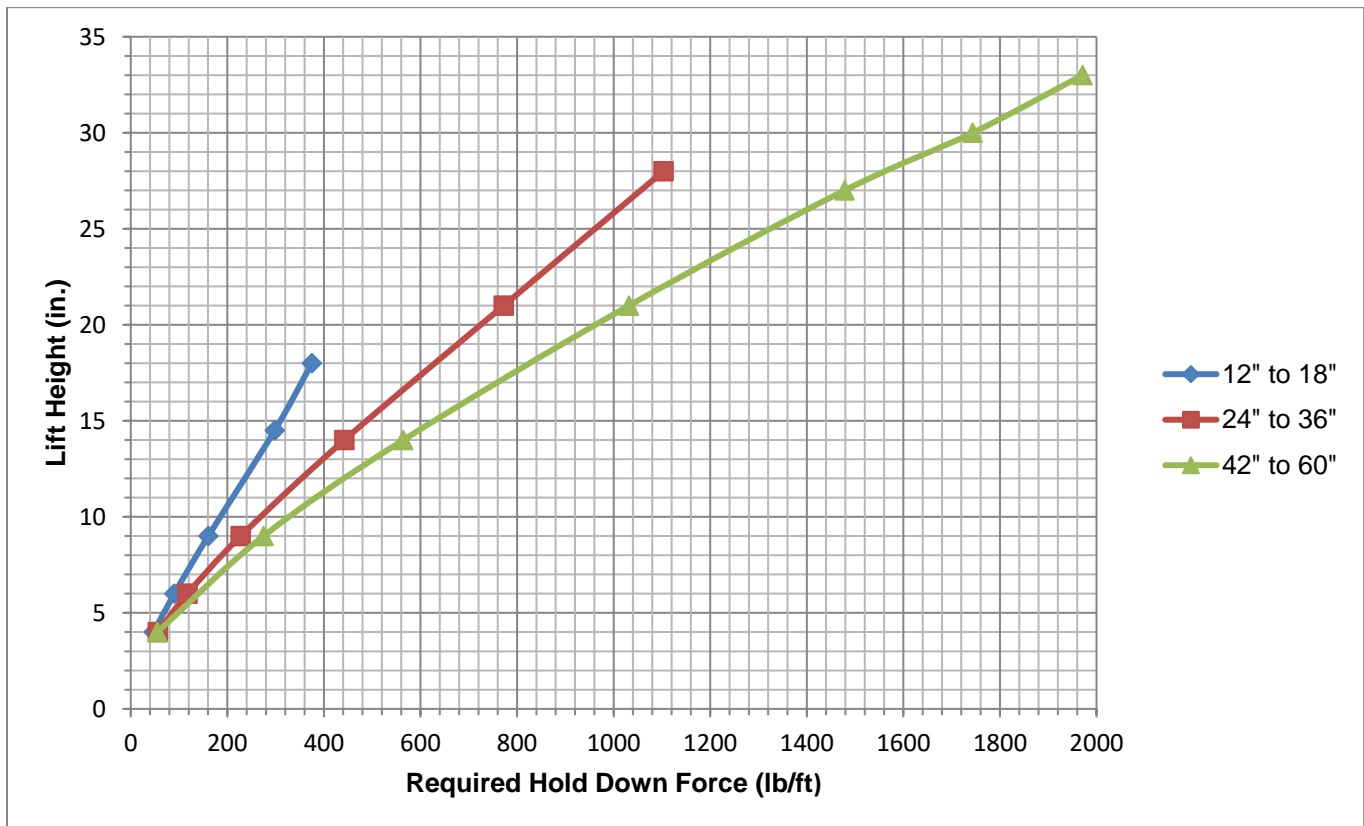

*Assumes a unit weight of flowable fill of 150 pcf and no water in the pipe at time of placement

Anchoring Systems

Probably the greatest concern associated with flowable fill during installation is its tendency to float the pipe. Flotation and misalignment issues are extremely critical and should not be ignored. When backfilling with flowable fill, the absence of soil overburden will cause the pipe to float since the pipe weight does not offset the flowable fill uplift. Therefore, the pipe must be anchored to keep the intended alignment and grade. There are a number of acceptable methods for anchoring the pipe in the trench. It may be assumed that flowable fill acts as a fluid with a density of 140 - 150 lb/cu ft. prior to stiffening. When properly designed, pipe restraints should account for buoyant forces exerted by the fluid.

Common methods include placing bags of soil or cement or heaping native material at intervals along the pipe, rebar placed in an "X" pattern above the pipe and anchored into the trench sidewall, or use of on-site construction equipment that can be left in place while curing (e.g. boom/bucket of excavator). Additional methods may include a pre-cast concrete swamp weight, or a commercially available screw anchor assembly. Anchor design and spacing shall be determined by the project design engineer. For other restraint options and additional technical information related to floatation, refer to Technical Note 5.05: *Pipe Flotation*.

Table 2
Hold Down Force, One Continuous Lift

Full Depth Placement of Flowable Fill Backfill		
Nominal Pipe Diam, in. (mm)	Lift Height (Pipe OD), in. (mm)	Required Hold Down Force, lb/ft (kg/m)
12 (300)	14.5 (368)	186 (276)
15 (375)	18 (457)	287 (426)
18 (450)	22 (559)	429 (638)
24 (600)	28 (711)	693 (1032)
30 (750)	36 (914)	1149 (1710)
36 (900)	42 (1067)	1566 (2330)
42 (1050)	48 (1219)	2044 (3042)
48 (1200)	54 (1372)	2590 (3854)
54 (1350)	61 (1549)	3311 (4927)
60 (1500)	67 (1702)	3990 (5938)



Technical Note

TN 5.03 HDPE Pipe Repair Options

Introduction

High-density polyethylene (HDPE) pipe is lightweight and very easy to handle. The attributes that make the pipe easy to use can also make it easy to abuse, resulting in damaged pipe or joints. This technical bulletin discusses some of the products available that can be used to repair damaged HDPE pipe or joints in the field.

Repair Options

One of the primary considerations in selecting a repair method is the degree of joint performance required. Watertight repairs are generally used on pipe with watertight joints, and soil-tight repairs on pipe with soil-tight joints. This helps keep costs in line and prevents the repair from being the weak area of the pipe system.

The way in which a pipe can be accessed is another primary consideration which influences what type of repair alternative is selected. Pipe that is not yet buried, or can be easily excavated, can be repaired from the exterior. If the pipe is buried and cannot be conveniently excavated, an internal repair may be the best alternative. If the pipe is too small to enter, there are companies with remote controlled equipment that can install the product. Each situation must be considered individually.

The repair options addressed below are divided into external repairs and internal repairs. During any pipe repair, backfill should be placed and compacted per project specifications to provide proper support for the pipe and coupler.

External Mechanical Repairs

Mar Mac Polyseal Pipe Coupler, 4- through 60-inch (100 - 1500 mm), consists of a mastic adhesive base layer, a cross-laminated polyethylene middle layer with a spun-bonded geotextile polypropylene cloth outer layer. The coupler incorporates a self-adhering rubberized bonding mastic and securing bands to insure a positive seal around the pipe. If the pipe itself is damaged, the damaged area will need to be removed and a new pipe section spliced in before installing a coupler around both ends. Polyseal Pipe Couplers are reasonably priced, especially when considering the quality of the finished repair, and are typically used with soil-tight smooth interior corrugated HDPE pipe products. *Note: Mar-Mac bands shall be installed in accordance with manufacturer's recommendations.*

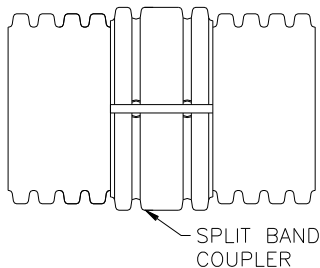

Snap couplers, 4- through 8-inch (100 – 200 mm), and *split band couplers*, 10- through 30-inch (250 – 750 mm), will provide a soil-tight repair with or without gaskets. This repair method should only be used if the damaged area is in a non-trafficked green area, is cosmetic in nature, confined to a single corrugation, and is not defined as structural damage. The coupler shall be centered around the damaged area of pipe and tightened down with the nylon straps. If the damaged area is large or significant, the damaged area is to be cut out, and replaced with a new section of pipe. The replacement section is to be 'spliced' in place using snap or split band couplers. They are a convenient, low-cost repair alternative, and are typically used to repair soil-tight smooth interior corrugated HDPE pipe products.

Concrete collars also provide a soil-tight repair, dependent on the integrity of the installation. Installing a concrete collar involves building a form around the area to be repaired and encasing it in concrete. A geotextile is usually wrapped around the repair area prior to pouring the collar to keep the concrete from seeping into the pipe. Typically, approximately 6" (0.15m) is excavated beneath the pipe to allow for proper application of the geotextile and concrete encasement. If the pipe itself is damaged, the damaged area shall be removed and a replacement pipe section spliced in prior to pouring the collar. In order to provide a greater level of joint performance, a gasket can be installed on the pipe in the concrete encasement. Concrete collars are typically more costly and time consuming than snap couplers or split band couplers but are reasonable repair options for soil-tight smooth interior corrugated HDPE pipe products.

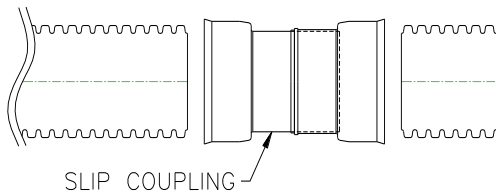
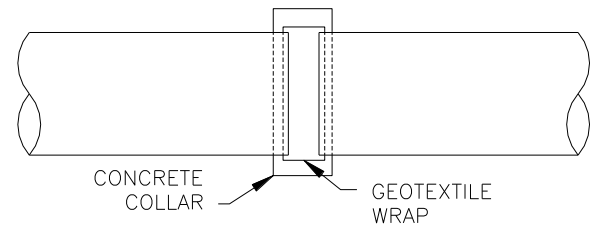

Slip Couplings 4- through 24-inch (100 – 600 mm), provides a watertight repair that will meet most pressure testing requirements, when installed correctly. The slip coupling uses PVC bells with gaskets. The gaskets are placed in the valleys on either side of the section to be repaired and slip couplings are then slid over the gaskets. PVC slip couplings are most commonly used with watertight smooth interior corrugated HDPE pipe products. .

External or Internal Repairs

Field welding may be an option for repairing either damaged sections of pipe or when cracks or gaps are present. Extrusion welding equipment is required for field welding, requiring man access to the section of pipe to be repaired. This requires a large enough pipe diameter for internal repair or removing backfill around the pipe for external repairs. Depending on the extent of the repair, a single bead of weld or HDPE sheet reinforcement will be used. The company performing the field welding will assist in determining access requirements and the extent of the necessary repairs.

Internal Repairs

Internal mechanical repair products generally consist of a flexible cylindrical gasket sleeve, which is expanded to conform to the inner wall of the pipe. The feasibility of this repair method depends on the size of the damaged section or joint and available access into the pipe. Internal mechanical seals slightly restrict the inside diameter of the pipe. This should be considered when assessing the risk of debris obstruction.

NPC Internal Joint Seal, 18- through 60-inch (450 – 1500 mm), consists of an EPDM rubber seal and stainless steel bands. The rubber seal is inserted into the pipe and positioned over the joint. A torque wrench is used to expand the bands against the inner wall of the pipe. The Internal Joint Seal is designed to seal joints – not repair damaged pipe sections. The damaged area of the pipe must be removed and a replacement section spliced in if necessary in order to use the Internal Joint Seal. This system may provide a watertight joint when installed as recommended. The manufacture should be contacted to verify the product meets the specific application requirements including test requirements, if specified. If pressure tests are required, NPC should be contacted to ensure that the product is suitable for the specific test criteria.

Internal mechanical seals will slightly restrict the inside diameter of the pipe. This should be considered when assessing the risk of debris obstruction.

Link Pipe Grouting Sleeve™, 4 through 60 inch (100 – 1500 mm), is a stainless steel grouting sleeve that is installed with an inflatable plug. The sleeve may be used to seal a joint or repair short sections of damaged pipe. The manufacture should be contacted to verify the product meets the specific application requirements including test requirements, if specified.

Internal chemical sealing is another method of internal joint repair using chemically activated gel or grout to minimize joint leakage. The grout is typically applied with specialized remote-controlled equipment. Test/seal packer is used to remotely seal a joint. The grouting chemicals are forced through the joint out into the surrounding soil where they gel with the soil. The gelled mass forms a waterproof collar around the pipe. The result is significantly reduced leakage. There are several types of chemical grouts available, and the manufacturer should be contacted to review the specific situation and any joint tightness or pressure test criteria. Companies such as Avanti International, Strata Tech Inc., and Carylton Corporation manufacture and/or install chemical grout. Stephen's Technologies *New Life Coatings* and *NewLife Liner Systems* as well as Avast Hydro-Lining International, are examples of companies that offer cured in place epoxy lining systems that have been effectively used with HDPE pipe. Most pipe diameters can be chemically grouted provided the grouting contractor has the appropriate equipment.

Manufacturer Contact Information

Contact the Regional Engineer or Application Engineering Department for assistance with other unique conditions or for contact information regarding any companies listed in this technical note.

Note: The HDPE pipe products are solely intended for the conveyance of fluids. Access into this product for maintenance, inspection, repair, or other reason should be done in strict accordance with OSHA recommendations for confined space entry.



Technical Note

TN 5.04 HDPE and HP Storm Connections to Manholes and Structures for Storm Sewer Applications

Introduction

A full line of pipe jointing options is available to fit the requirements of nearly any storm drain or gravity flow project specifications. The joints available range from soil tight split couplers to gasketed soil-tight (ST) and watertight (WT) pipe. When connecting pipe to drainage structures it is important to make those connections with a joint performance at least equal to that of the piping system.

Connection Options

Soil-Tight Performance

When using soil-tight pipe in non-watertight applications, it may be acceptable to grout the void space between the pipe and drainage structure.

Watertight Performance

When using watertight pipe for testable systems, requiring some degree of watertight performance, it is necessary to provide additional measures to insure a watertight connection between the pipe and structure. ASTM F2510/F 2510M, "Standard Specification for Resilient Connectors Between Reinforced Concrete Manhole Structures and Corrugated High Density Polyethylene Drainage Pipes," is the governing standard for corrugated HDPE pipe-manhole connections, but specific performance/installation requirements should be verified for each specific project. Along with a full line of adapter fittings available, including the Waterstop® Gasket, are flexible boot fittings provided by other manufactures. Fitting dimensions should be supplied to the manufacturer to insure the proper fitting size and manhole boot connector are supplied.

Installation Recommendations

When installing a manhole adapter on the upstream end, the fitting may be over inserted into the structure temporarily while the adjoining pipe is laid. The spigot piece is then pushed back through the structure and connected to the bell end when pushing the joint together, as shown to the right.

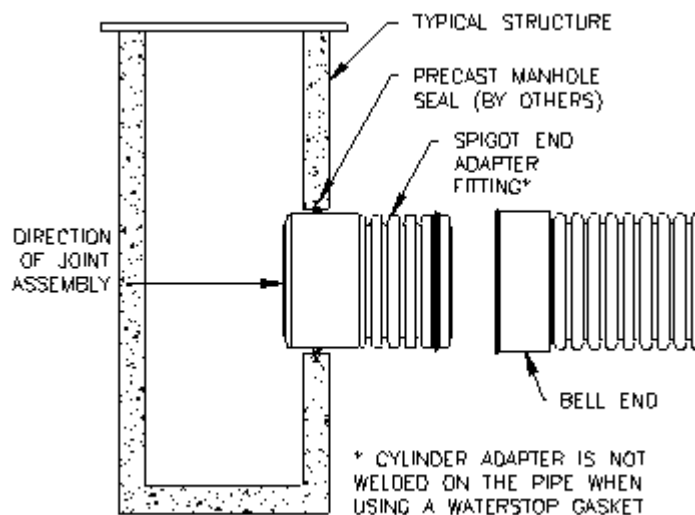

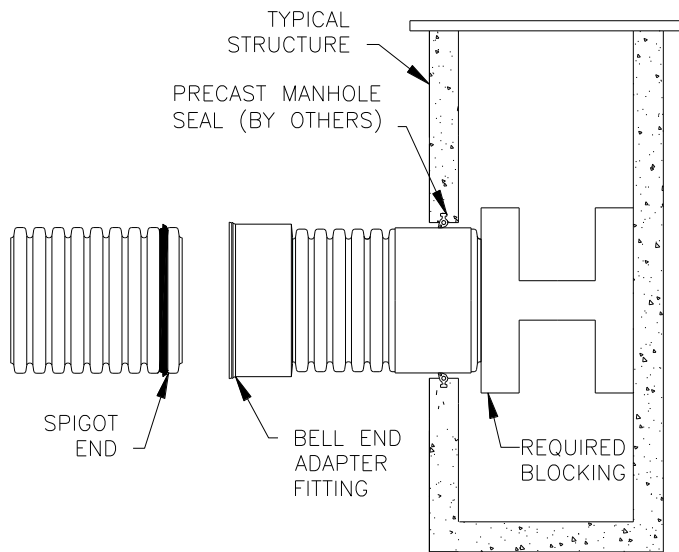

Alternately, when using the adapter fitting in the downstream end of the structure, before pushing the bell and spigot together from inside the structure, it is necessary to provide blocking at the structure to prevent the fitting from moving in the structure, as shown to the left.

Summary

The selection of which manhole connection is best suited for a project is based on the joint and connection requirements along with preferred manhole connection method for the region. It is imperative that prevailing regulations be consulted before selecting a manhole connection. Other options may be available for watertight manhole connections. Refer to 200 Series Standard Details for installation and connection-specific details. Contact your Regional Engineer or Application Engineering for further assistance.



Technical Note

TN 5.05 Pipe Flotation

Introduction

The light weight of high density polyethylene (HDPE) and polypropylene (PP) pipe make it desirable because of the ease of handling and installation but this same benefit also makes these thermoplastic pipes prone to flotation. All pipe products, such as concrete and corrugated metal, are prone to flotation under the right circumstances. In fact, all pipe materials and other buried structures are subject to flotation. When the uplift on the pipe or structure exceeds the downward force of the weight and load it carries, the pipe (or structure) will rise or heave. Where flotation is a possibility, proper installation and/or anchoring of the pipe is critical. This document provides an analysis on minimum cover heights required to prevent pipe flotation for thermoplastic pipe sizes 12"-60". Buoyant force due to flowable fill is also discussed.

Hydrostatic Uplift Due to a High Water Table

Buoyancy becomes an issue in buried pipe when the groundwater encroaches into the pipe zone. For projects where a high groundwater table or water surrounding the pipe is expected, precautions should be taken to prevent the flotation of thermoplastic pipe. The vertical hydrostatic uplift force, due to the water table, must be balanced by the soil overburden and the weight of the pipe in order to prevent flotation of the pipe. The vertical hydrostatic uplift force, U , can be calculated from Equation 1 below:

$$U = \frac{\pi}{4} D^2 \delta_w \quad (1)$$

where U = lb/linear ft of pipe
 D = O.D. of the pipe in question, ft.
 δ_w = unit weight of water = 62.4 lb/ft³

Soil loads experienced by a pipe at varying water table depths (W_{soil}) can be calculated from Equation 2. Figure 1 illustrates each of the three cases seen in field installations where buoyancy becomes a concern, and also clarifies all of the parameters contained within Equation 2.

$$W_{\text{soil}} = \delta_{\text{dry}} H_{\text{dry}} D + (\delta_{\text{sat}} - \delta_w)(H_{\text{sub}} + 0.1073D)D \quad (2)$$

where W_{soil} = weight of soil overburden, lb/linear ft of pipe
 δ_{dry} = dry unit weight of the soil, lb/ft³
 H_{dry} = depth of dry soil, ft.
 H_{sub} = depth of submerged soil over top of pipe, ft.
 δ_{sat} = saturated unit weight of the soil, lb/ft³
 $\delta_{\text{sat}} - \delta_w$ = submerged unit weight of the soil, lb/ft³

Figure 1
Installation Conditions for Possible Flotation of Thermoplastic Pipe

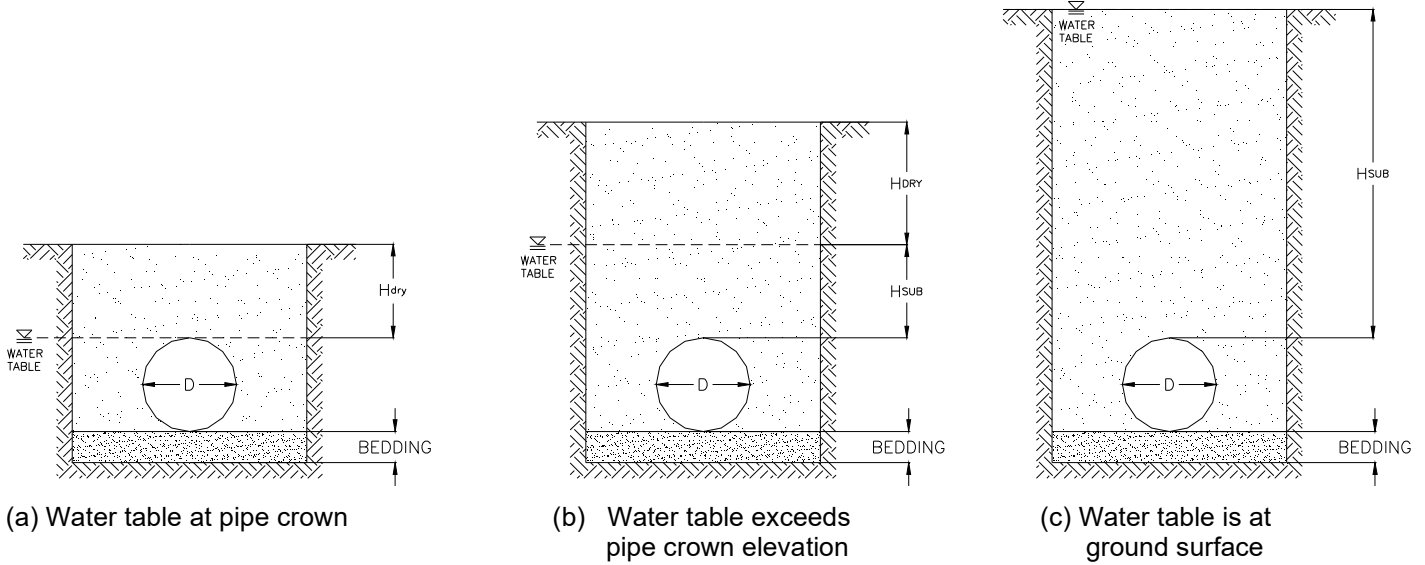

The typical weights (W_{pipe}) and average outside diameters are shown in Table 1.

Table 1
Approximate Weights of ADS Thermoplastic Pipe

Nominal Diameter in. (mm)	Nominal OD in. (mm)	Dual Wall Pipe Weight lb/ft (kg/m)	Triple Wall Pipe Weight lb/ft (kg/m)
4 (100)	4.6 (117)	0.44 (0.6)	N/A
6 (150)	7.0 (178)	0.85 (1.3)	N/A
8 (200)	9.5 (241)	1.5 (2.2)	N/A
10 (250)	12 (305)	2.1 (3.1)	N/A
12 (300)	14.5 (368)	3.2 (4.7)	N/A
15 (375)	18 (457)	4.6 (6.8)	N/A
18 (450)	22 (559)	6.4 (9.5)	N/A
24 (600)	28 (711)	11.0 (16.4)	N/A
30 (750)	36 (914)	15.4 (22.9)	20.7 (30.8)
36 (900)	42 (1067)	19.8 (29.4)	24.2 (36.0)
42 (1050)	48 (1219)	26.4 (39.3)	31.9 (47.5)
48 (1200)	54 (1372)	31.3 (46.6)	41.8 (62.3)
60 (1500)	67 (1702)	45.2 (67.3)	55.0 (81.9)

N/A indicates the pipe is not available in the respective diameter

The minimum depth of cover (H) required to resist uplift can be calculated by equating the sum of the downward forces to the sum of the upward or buoyant forces. While there are varying methods to account for soil load distribution on the pipe, for conservative minimum cover requirements, the soil load is assumed to be the soil column directly above the outside diameter of the pipe as illustrated in Figure 2(a). Therefore, minimum cover is calculated using Equations 3 and 4 below:

$$U \leq W_{Soil} + W_{Pipe} \quad (3)$$

where W_{pipe} = weight of the pipe, lb/linear ft of pipe

$$H = H_{dry} + H_{sub} \quad (4)$$

Figure 2
Forces Affecting Flotation

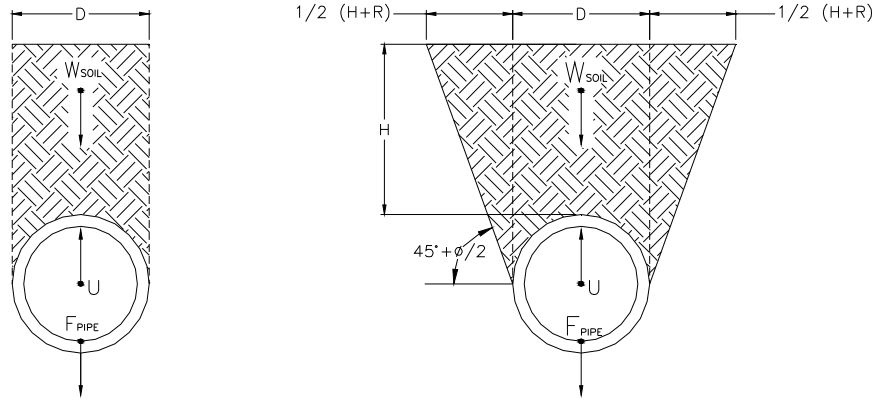

(a) Soil Column Loading Conditions

(b) Prism Loading Conditions

Table 2
Minimum Recommended Cover to Prevent Flotation of ADS Thermoplastic Pipe

Nominal Diameter in. (mm)	Minimum Cover in. (mm)
4 (100)	3 (77)
6 (150)	4 (102)
8 (200)	5 (127)
10 (250)	7 (178)
12 (300)	9 (228)
15 (375)	11 (280)
18 (450)	13 (330)
24 (600)	17 (432)
30 (750)	22 (559)
36 (900)	25 (635)
42 (1050)	29 (737)
48 (1200)	33 (838)
60 (1500)	40 (1016)

Calculation Notes:

1. The pipe is assumed to be empty. This not only simplifies the calculations but creates a condition that would encourage flotation. Unless the system is constructed to be watertight, this condition would not likely be found in an actual installation.
2. The outside diameter of the corrugated pipe was used to determine soil and water displacement.
3. Saturated soil density used was 130 pcf which is typical for many saturated soil mixtures. Soils of greater densities will reduce the chance of flotation.
4. The water table was assumed to be at the ground surface, as illustrated in Figure 1(c), simulating a fully saturated soil. This assumption creates a "worst case" condition to yield more conservative results.
5. The soil load prism shown in Figure 2(a) was used to determine soil weight.
6. For structural purposes, a minimum cover of 12" (0.3m) shall apply for 4"-48" (100-1200mm) pipe, and 24" (0.6m) for 60" (1500mm) pipe.

Example 1: Calculate the minimum depth of cover required to prevent 48" N-12 HDPE from floating when the water table is at the top of grade. The dry and saturated unit weights of the soil are 110 lb/ft³ and 130 lb/ft³, respectively.

Solution: $U > W_{Soil} + W_{Pipe}$

$$W_{pipe} = 32.0 \text{ lb/ft (from Table 1)}$$

$$U = \frac{\pi}{4} (4.5)^2 (62.4) = 992.4 \text{ lb/ft}$$

The water table is at top of grade, so Figure 1(c) applies. Since $H_{dry}=0$, the first term in Equation 2 is eliminated:

$$\text{Therefore, } W_{soil} = (130 - 62.4)[H_{sub} + (0.1073)(4.5)](4.5) + 32 = 304.2 H_{sub} + 146.9 + 32$$

$$\begin{aligned} \text{Equation 3 then yields:} \quad & 992.4 = 304.2 H_{sub} + 178.9 \\ \therefore H_{sub} = 2.67' = 32.1" \quad & \text{(use 33")} \end{aligned}$$

Finally, calculate minimum cover from Equation 4: $H = H_{sub} = \underline{33"}$

The above calculations are conservative. The angle of internal friction of the soil, ϕ , and the coefficient of lateral earth stress, K_o , are not accounted for in the above equations. These parameters are best left to the geotechnical engineer. If these parameters are added to the above calculations, the depth of cover required would be reduced.

Anchoring Systems

In many instances pipe flotation may simply be addressed with adequate cover. In those situations where adequate cover cannot be achieved, there are a number of acceptable alternate methods for restraining the pipe. Several examples are shown in Figure 3.

Due to the variations in in-situ soil densities, water table heights, and the restraining force of the anchors, the Engineer should evaluate the project-specific conditions to determine the required anchor type and spacing to prevent flotation. The maximum spacing between anchor supports should not exceed 10 feet. In this manner, pipe is supported at each joint and at the midpoint of each length of pipe to ensure adequate stabilization.

Figure 3
Pipe Stabilizing Alternatives

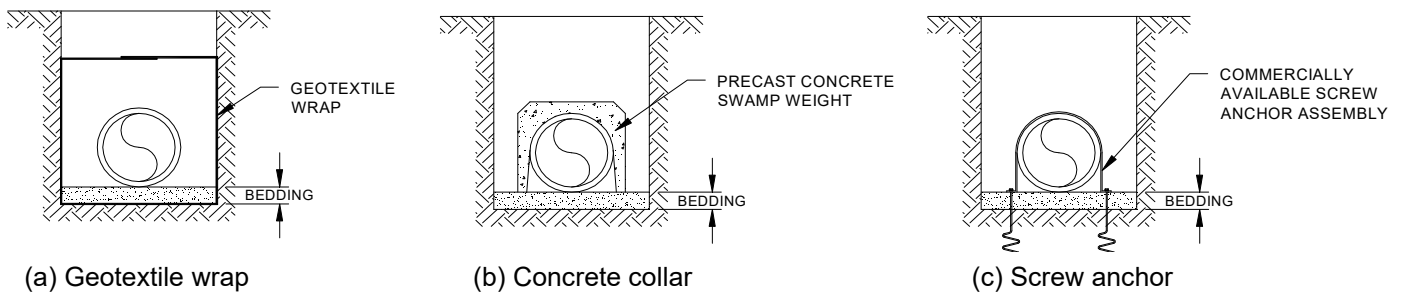

Uplift Due to Flowable Fill Backfill

Flowable fill, also known as controlled low strength material (CLSM), controlled density fill (CDF), and slurry fill, is utilized as an alternate to compacted granular fill. Flowable fill typically consists of Portland Cement, sand, water, and fly ash. Uplift due to CLSM backfill can be calculated from Equation 5.

$$U = \frac{A_{disp} \delta_{FF}}{144} \quad (5)$$

Where, A_{disp} = Area of pipe displaced by flowable fill, in²
 δ_{FF} = Unit weight of flowable fill, lb/ft³
U = Uplift due to flowable fill backfill, lb/ft

Due to the vast differences in the unit weights between water and flowable fill, uplift caused by flowable fill can be greater than two times that of hydrostatic uplift. When backfilling with flowable fill, the pipe will float in the absence of soil overburden, since the weight of the pipe will not offset the vertical uplift. Precautions must be taken to ensure the pipe remains on its intended alignment and grade. This is commonly done by anchoring the pipe in place or placing the flowable fill in incremental lifts. Refer to Technical Note 5.02: Flowable Fill Backfill for Thermoplastic Pipe for common anchoring methods and additional technical information related to placing flowable fill as backfill.



Technical Note

TN 5.06 Culvert Sliplining with HDPE Pipe

Introduction

An abrasive or corrosive environment can cause premature deterioration of some types of pipe. In lieu of a total replacement, sliplining the existing pipe with a durable material may be an economical method to significantly extend the service life. Polyethylene pipe, because of its resistance to aggressive environments, is often the product of choice to slipline deteriorated pipes. This technical bulletin describes the site and installation considerations that must be evaluated before using HDPE pipe in these applications.

Access to the Host Pipe

The “host” pipe may be open on both ends, as in a culvert application, or it may be accessible only through a manhole opening, as in a storm sewer application. Open-ended applications are more appropriate for HDPE pipe products, provided they do not require the pipe to be bent in order to enter the host pipe. If access can only be made through a manhole, HDPE pipe products may not be acceptable because they cannot be bent sufficiently.

Diameter of the Host Pipe

The greater of either the outside diameter of the HDPE pipe or coupler should be compared to the inside diameter of the host pipe. This may be accomplished by attempting to pull a short section (~2 feet in length) through the host pipe as a trial run. The host pipe should be clean; free from sediment and debris so as to not interfere with the installation of the liner pipe. Sliplining installations may be subject to thermal length changes of 0.07-inches per 100 feet of pipe per change in degree F. One should design to allow for these changes during installation. To allow for proper grout placement and clearance, the relined pipe should have a maximum outside diameter no greater than 90% of the inside diameter of the host pipe. The maximum outside diameters of ADS products are shown in Table 1.

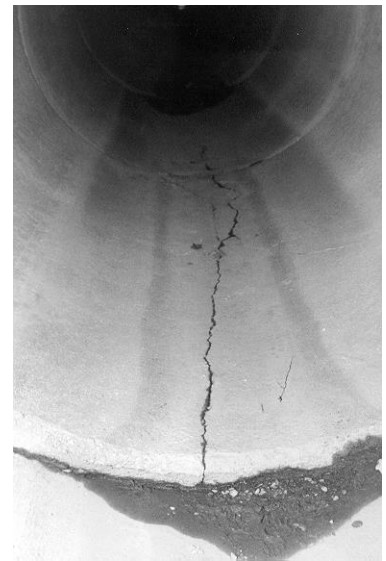

Table 1
HDPE Pipe Dimensions

Nominal Inside Diam. in (mm)	Max Outside Diam. in (mm)	Nominal Inside Diam. in (mm)	Max Outside Diam. in (mm)
4 (100)	4.8 (122)	24 (600)	28.4 (721)
6 (150)	7.0 (178)	30 (750)	35.6 (904)
8 (200)	9.5 (241)	36 (900)	41.4 (1052)
10 (250)	12.0 (305)	42 (1050)	48.0 (1219)
12 (300)	14.5 (367)	48 (1200)	55.0 (1397)
15 (375)	17.8 (452)	54 (1350)	61.0 (1549)
18 (450)	21.5 (546)	60 (1500)	67.3 (1709)

Length of Installation

HDPE pipe joints are not designed to withstand large pulling forces. Furthermore, pushing the liner pipe in through the host pipe may damage the corrugations at the pipe ends as they butt up against each other. The method of installation will affect, in large part, the maximum length that can be slip lined without damaging the pipe. Using skids, especially in a corrugated host pipe, will help minimize resistance between the two surfaces. Skids could be as simple as a pair of 2X4's placed near the invert. A push-and-pull technique keeps stress on the joints to a minimum. Projects in excess of 100 ft (30 m) between access points are addressed in Technical Note 5.11: *Slip Lining Extended Lengths with HDPE Pipe*.

Hydraulic Considerations

Original design calculations may be referenced, however careful attention should be given to changes in land use which would change the calculated runoff tributary to the culvert. Once a discharge has been determined, the required size of the HDPE pipe may be established. If original design calculations are not available, the project engineer should complete a thorough drainage study. A culvert size can be selected based on watershed attributes, design storm, allowable headwater, culvert entrance conditions and any other related design factors.

In many cases, where culverts are too deep to make replacement practical, slightly reduced hydraulics may be an acceptable tradeoff to an expensive replacement. Typically, gravity flow systems are designed using Manning's Equation with a conservative 'n' value of 0.012 for HDPE. It should be noted that culverts in need of relining do not have Manning's 'n' values typical of original design values. Relining with smooth interior HDPE pipe may actually increase the capacity of the deteriorated culvert.

Structural Requirements

Failing culverts in need of relining may eventually deteriorate into a conduit with no structural integrity at all. For this reason, it is important to reline with a culvert capable of handling the loads based on its installation assuming no load reduction from the host pipe. Loading for Highway and pavement tunnels shall be based upon a continuous load carrying structure for the height of cover under HS-25 loading. Voids between the surrounding soil and the host pipe shall be pressure grouted to ensure structural integrity and resistance to thermal effects. For more information for determining the structural capacity of HDPE, refer to the Structures section of the *Drainage Handbook*.

Installation of HDPE in Host Pipe

Before the HDPE pipe is inserted into an existing culvert for relining, it is critical to inspect the existing culvert for any objects or obstructions, which may be extending into the barrel of the existing culvert to be relined. Failure to do this may result in a damaged reline.

Insertion Forces

Once the culvert is clear, the new material may be pushed through. It is important to determine the maximum insertion force that can be applied to the culvert. This will prevent the pipe wall profile from buckling in the axial direction under excessive insertion loading.

In cases where the new culvert will be two or more sizes smaller than the existing culvert, it is possible to construct mechanisms to transport the new material along the existing culvert without sliding across the invert. Although ideal for construction, many times there is insufficient room to allow this technique.

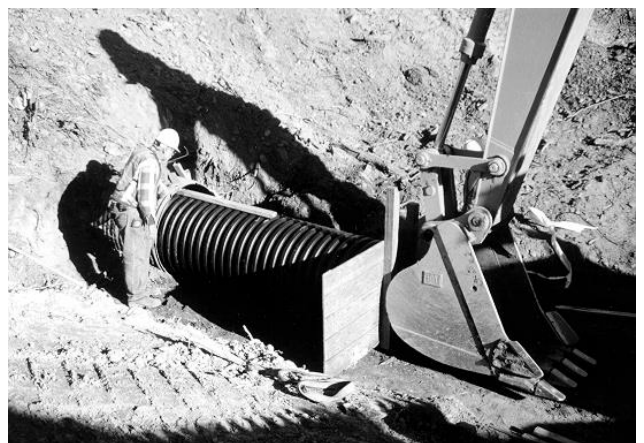

Grouting Procedures

When relining a culvert with HDPE pipe, it is recommended to fill the void space between the existing culvert and the new material with a grout material. The grout material is often a controlled low strength material – controlled density fill (CLSM-CDF). A CLSM or flowable fill material will help provide uniform support on the sides of the pipe, maintain a consistent soil density, provide lateral support for the pipe, and eliminate point loads. For more information on flowable fill mix, refer to Technical Note: *Flowable Fill Backfill for Thermoplastic Pipe*.

It is common for aging metal culverts to have deteriorated or completely destroyed inverts. This allows the fluid carried through the culvert to create void space under the pipe, creating an undesired design consideration. The grout material will help plug and fill any fractures or holes in the existing culvert along with structurally stabilizing the system from thermal, hydrostatic pressure, point loads, and function as a water barrier.



To ensure proper alignment and prevent joint separation, the pipe should be anchored against flotation when placing the grout material. Grouting in layers thin enough such that they don't float the pipe helps tremendously. Each layer should be allowed to set up between pours. Contractors may have other techniques that will also prevent flotation such as the use of deadweight inside the pipe. Regardless of the method used, it is also important to avoid applying point loads to the pipe. For more information on flotation and anchoring methods, refer to Technical Note: *Pipe Flotation*.

When HDPE pipe, or any flexible pipe, is used as a liner, it is very important not to use excessive grout pressure. In most circumstances, the joint, not the wall strength, will be the limiting factor for maximum allowable grouting pressure. Including a factor of safety, the recommended maximum grouting pressure for water tight pipe products is 5 psi; this

value may vary based on specific site conditions and specific products used. Due to the application method of grout, water tight pipe is recommended for sliplining applications. During the grouting operation, gauges should be used to monitor the grout pressure exerted on the pipe system. For some applications, hydrostatic head pressure may increase the expected pressure on the pipe from the grouting. Additional pressure may be a result of the slope and/or diameter of the pipe, elevation changes between the pipe and the gauge, and other conditions that should be considered during the design. The sum of all pressures that will be exerted on the pipe should not exceed the recommended maximum pressure for the application.



Technical Note

TN 5.07 Post Installation Testing for HDPE Pipe

Introduction

HDPE pipe is often tested after or during installation to ensure a sound installation was accomplished. Types of post installation field testing include deflection testing and joint testing. Specific testing required for the project will be found in the project specifications. This technical note is not meant to supersede any project specification, but should be used in conjunction with the project specification and national testing standards as it relates specifically to HDPE pipe.

Deflection Testing

An important feature of any flexible pipe is its ability to deflect, or oval, under load without structural distress. Flexible pipe *must* deflect in order to mobilize the strength of the surrounding backfill. Deflection allows the load to be transferred from the pipe to the surrounding backfill. As a result, flexible pipe can withstand very high loads as a relatively light structure.

According to current thermoplastic design procedures, deflection is defined as a service limit. The designer, considering all site conditions, will set this service limit in order to perform a proper design evaluation. Deflection in excess of this service limit does not necessarily result in strength limits being exceeded, i.e. system failure. For more information on service and strength limit states, see the *Structures* section of the Drainage Handbook. HDPE can be expected to perform satisfactorily in most applications with 5% or 7.5% deflection and so it is typical of designers to choose a service limit in this range.

When testing for allowable deflection limits, the minimum inside diameter should be used when establishing mandrel sizing. The minimum inside diameter accounts for the allowable manufacturing tolerances. Table 1 lists the inside diameters that result from 5% and 7.5% deflection from the minimum inside diameter. Values listed in Table 1 should be used for sizing mandrels for deflection testing. Mandrels may be obtained from a variety of commercial suppliers.

Table 1
Base Inside Diameters for HDPE Pipe

Nominal Pipe Diameter (in.)	Base Inside Diameter (in.)	Base Inside Diameter with 5% Deflection (in.)	Base Inside Diameter with 7.5% Deflection (in.)
4	3.88	3.68	3.59
6	5.82	5.53	5.38
8	7.76	7.37	7.17
10	9.69	9.21	8.97
12	11.63	11.05	10.76
15	14.54	13.82	13.45
18	17.45	16.58	16.14
24	23.27	22.10	21.52
30	29.08	27.63	26.90
36	34.90	33.16	32.28
42	40.72	38.68	37.66
48	46.54	44.21	43.05
54	52.35	49.73	48.43
60	58.17	55.26	53.81

*Value is per AASHTO M252¹ (4"-10" dia.) and AASHTO M294² (12" – 60" dia.).
If designing to a specific standard, please review allowable minimum diameter.

It is important to understand that mandrel testing is a go/no-go test. If any line were to not pass a mandrel, it is important to determine the cause. Obstructions in the line, not associated with deflection, may influence the test. Visual inspection is recommended in the event of a no-go result.

Joint Testing

Joint testing is an important part of any gravity sewer system, both in testing for infiltration and exfiltration. Infiltration aids to estimate the amount of sewer water that will be conveyed to, and ultimately treated by, the waste water treatment plant. Exfiltration aids to estimate the loss of sewage water into the surrounding soil. The two primary ways of testing sewer pipe joints for infiltration and/or exfiltration is using air or water to create a constant pressure within the system.

Exfiltration Testing with Air

Air is a compressible gas and so it is extremely important one adheres to the appropriate safety regulations outlined in OSHA and project specifications. There are two primary national testing standards that may be applied to joint testing HDPE: ASTM F1417 *Standard Test Method for Installation Acceptance of Plastic Gravity Sewer Lines Using Low-Pressure Air*, and ASTM F3058 *Preliminary Field Testing of Thermoplastic Pipe Joints for Gravity Flow (Non-Pressure) Sewer Lines*. When either standard is specified by the project plans, one should review the standards carefully and follow the testing procedure and safety precautions outlined. The below commentary on the ASTM testing procedures should be considered a summary and does not replace the testing procedures outlined in their respective specifications.

ASTM F1417 entails testing a run of pipe from one manhole to the next adjacent manhole. Inflatable plugs are positioned into the manholes and secured. Air is introduced into the pipe line and gradually builds pressure. Once the line has been pressurized and is stable at 4.0-psi, the pressure is decreased to 3.5-psi at which time the line must not lose more than 0.5- or 1.0-psi (whichever is specified by the design engineer) in the specified amount of time. Table 2 below summarizes the minimum time that must be reached for less than 0.5- or 1.0-psi of pressure drop, depending on the diameter and length of pipe being tested.

Table 2
Time to Pressure Drop for HDPE (per ASTM F1417)

Pipe Diameter	Pressure Drop (psi)	Minimum Test Time (min:sec)	Length for Minimum Time, (ft)	Time for Longer Lengths, (sec)	Time for Length Shown, (min:sec)							
					100 ft	150 ft	200 ft	250 ft	300 ft	350 ft	400 ft	450 ft
12	0.5	5:40	199	1.709 L	5:40	5:40	5:42	7:08	8:33	9:58	11:24	12:50
	1.0	11:20		3.418 L	11:20	11:20	11:24	14:15	17:05	19:56	22:47	25:38
15	0.5	7:05	159	2.671 L	7:05	7:05	8:54	11:08	13:21	15:35	17:48	20:02
	1.0	14:10		5.342 L	14:10	14:10	17:48	22:15	26:42	31:09	35:36	40:04
18	0.5	8:30	133	3.846 L	8:30	9:37	12:49	16:01	19:14	22:26	25:38	28:51
	1.0	17:00		7.692 L	17:00	19:13	25:38	32:03	38:27	44:52	51:16	57:41
24	0.5	11:20	99	6.837 L	11:24	17:57	22:48	28:30	34:11	39:53	45:35	51:17
	1.0	22:40		13.764 L	22:47	34:11	43:34	56:58	68:22	79:46	91:10	102:33
30	0.5	14:10	80	10.683 L	17:48	26:43	35:37	44:31	53:25	62:19	71:13	80:07
	1.0	28:20		21.366 L	35:37	53:25	71:13	89:02	106:50	124:38	142:26	160:15

Data taken from ASTM F 1417³ and Uni-Bell, Uni-B-6-98⁵.

It may not be necessary to hold the test for the entire time period listed above when it is evident that the rate of air loss is zero or less than the allowable pressure drop and authorized by the approving authority¹.

When the pipe is large enough to be physically accessed, it may be desirable to test individual joints for safety reasons. In these cases, one may consider joint testing in accordance with ASTM F3058, also known as a joint isolation test. ADS recommends a joint isolation test, in lieu of a full line test, for testing pipe diameters 36" and larger for safety reasons. This test is typically done with air, though water may also be used, and involves the use of special testing equipment. The equipment consists of two inflatable bladders, placed on each side of the joint, creating an open center cavity between them. The bladders are inflated and then the center cavity is pressurized to 3.5 psi. The joint passes the test if the pressure is held for 5 seconds without dropping more than 1.0-psi. For all practical purposes, this is a go/no-go test. Final acceptance of the pipeline per this testing method shall be at the discretion of the Design Engineer. One advantage of this type of test is the ability for the installer to quickly test the joint immediately after installation, allowing for any corrective measures to be taken early on in the project.

Infiltration/Exfiltration with Water

Testing gravity sewer joints via water infiltration or exfiltration is a common practice. For HDPE, this testing should be conducted in accordance with ASTM F2487 *Standard Practice for Infiltration and Exfiltration Acceptance Testing of Installed Corrugated High Density Polyethylene Pipelines*. These standards entail first observing the ground water conditions and, if applicable, measuring the infiltration rate of the ground water through the joints. If ground water is not applicable, then the line is filled with water and the leakage is observed through exfiltration.

Manholes shall be tested separately and independently of the pipe line to the requirements established in the project specifications. When water level is measured in the manhole for the exfiltration test, the leakage associated with the manhole shall be subtracted from the overall leakage of the test section to establish a pass or fail grade for the pipe.

Allowable Leakage

The allowable leakage rate for HDPE is 200 gallons/in-dia/mi-pipe/day for both infiltration and exfiltration when tested in accordance with ASTM F2487

Conclusion

HDPE pipe is intended for gravity flow drainage applications and may be tested for deflection and joint tightness as discussed in this technical document. It is important to note that the testing procedures are no different than for other gravity flow drainage products currently being used in the market. This document does not purport to address the safety concerns associated with testing HDPE pipe. Any questions associated with testing HDPE pipe can be directed to your local representative.

References

1. AASHTO M252, *Standard Specification for Corrugated Polyethylene Pipe Drainage Pipe*, AASHTO, 2012
2. AASHTO M294, *Standard Specification for Corrugated Polyethylene Pipe, 300 to 1500 mm (12 to 60 in.) Diameter*, AASHTO, 2015
3. ASTM F1417, *Standard Test Method for Installation Acceptance of Plastic Gravity Sewer Lines Using Low-Pressure Air*, ASTM, 2005
4. F3058, *Preliminary Field Testing of Thermoplastic Pipe Joints for Gravity Flow (non-Pressure) Sewer Lines*, ASTM, 2016.
5. Uni-B-6-98, *Recommended Practice for Low-Pressure Air Testing of Installed Sewer Pipe*, Uni-Bell PVC Pipe Association, 1998
6. ASTM F2487, *Standard Practice for Infiltration and Exfiltration Acceptance Testing of Installed Corrugated High Density Polyethylene Pipelines*, ASTM, 2006



Technical Note

TN 5.08 Laser Profiling of Flexible Pipe

Introduction

Historically, the use of closed-circuit television (CCTV) inspection technologies has been a common method to provide post installation inspection of various pipe types. This technology can provide a qualitative analysis of the interior of a pipeline, but it can be limited due to the subjective nature of the visual assessment process. Laser profiling, which was originally developed for the thermoplastic Cured in Place Pipe industry, is a new technology that can provide precise measurements of pipe parameters. However, there are some current limitations with the technology that can lead to sporadic and erroneous results. Additionally, the limitations can lead to precise but inaccurate results. The purpose of this Technical Note is to provide a discussion of the current state of the technology.

Laser Profiling Description

Laser profiling is a non-contact inspection method used to determine a pipe-wall profile. The method uses a machine vision technique known as optical triangulation as shown in Figure 1. This involves projecting a laser onto the interior surface of the pipe, and an image of this light spot is then formed on a sensor, usually a digital camera. By knowing the position of the laser with respect to the camera and establishing which part of the sensor the light spot is viewed through, one can find the exact location of the pipe wall with respect to the laser and camera. The radial distance data for several positions along the pipe is compiled and plotted yielding a three dimensional wireframe image of the pipe.¹

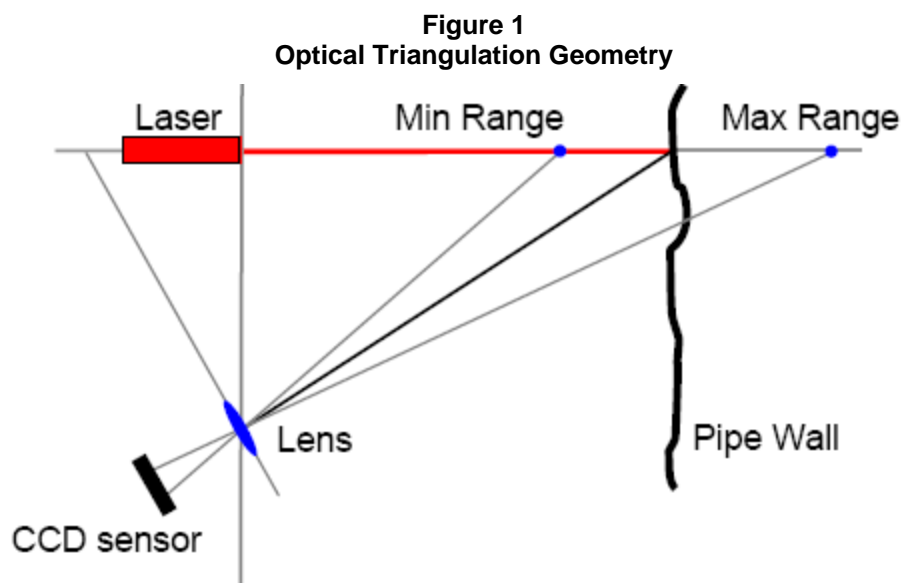

Position and Orientation Tracking

The primary difficulty with the use of laser profile equipment is tracking the position and orientation of the equipment that is used. Absolute positioning systems could be employed that correlate the position of the equipment to an external landmark but these are difficult to implement. The more common method to account for position and orientation tracking is with the use of a relative positioning device such as gyroscopes or inclinometer. However, this type of positioning tracking system can be susceptible to many errors.

Gyroscopes use the earth as reference point. In doing so, the gyroscope can not distinguish whether the equipment that the laser is situated on or the pipe has changed position. This can lead to errors in ovality readings unless the laser profiling software can distinguish that the equipment has shifted and not the pipe. This problem can materialize in one of two ways. First, the profiling equipment has meandered off of the pipe axis by a certain horizontal angle. This can lead to a false positive result exhibited by excessive horizontal ovality deflection readings in a round pipe. Secondly, the equipment encounters a bump or offset which results in the equipment meandering off of the pipe axis by a certain vertical angle. In this case, this can lead to an erroneous pipe profile exhibited by excessive vertical deflection readings in a round pipe.

Currently, the software programs for laser profiling can not account for meandering of equipment. To help control equipment wander, one system spaces wheels at 120 degrees in the pipe regardless of diameter. This can lead to positive results for pipe diameters that are 24-inch and less. However, this method can have limited success in the inspection of large diameters as the potential for meander greatly increases. This can lead to a false negative result exhibited by excessive horizontal ovality deflection readings in a round pipe. Software programs currently in place are more effective in dealing with bumps and offsets in the pipe. The systems use an inclinometer to take readings which account for vertical inconsistencies in the pipeline and are more successful in limiting false positive results in vertical ovality deflection readings.

Non Ideal Pipe Conditions

In addition to bumps or offsets, the presence of sediment, water and/or other debris can create vertical inconsistencies resulting in a pipe profile illusion inconsistent with the actual pipe profile condition. One known laser profiling system can operate in pipelines that are partially filled with water. The acceptable depth will vary based on the pipe diameter and equipment utilized. The software package that is utilized can recognize the presence of water and correct the profiling data accordingly. However, this is not consistent in the industry. Other systems require operator input to account for water in the pipeline. This operator input can lead to errors with regards to data interpretation and effect repeatability of the results.

The presence of debris is somewhat more complicated. When debris is encountered, the equipment can meander off of the pipe axis by a certain vertical angle. In this case, this can lead to an erroneous pipe profile exhibited by excessive vertical deflection readings in a round pipe. As with water, one laser profiling system can operate in a pipeline that has accumulation that is 10 percent of the pipe diameter. The software package can recognize the presence of the debris and correct the profiling data accordingly. As with water interpretation, this is not consistent in the industry. Other systems require operator input to account for debris in the pipeline. This operator input can lead to errors with regards to data interpretation and effect repeatability of the results.

For the best results, the pipe should be clear of all sediment, debris and water. Otherwise, considerable post-inspection data analysis will be necessary to distinguish whether deflection readings were actual or a false positive created non ideal pipe conditions.

Environmental Factors

The laser profile may be disturbed, impeded or dispersed due to atmospheric density differences relating to fog or dew formation in the pipeline. This can affect the light intensity in the pipeline which in turn will negatively impact the laser profiling process. As mentioned previously, the technology involves projecting a laser onto the interior surface of the pipe, and an image of this light spot is then formed on a sensor, usually a digital camera. If the fog or dew formation is of sufficient intensity, the laser may be reflected and never reach the interior surface of the pipe. This may result in laser scatter which in turn may lead to erroneous readings. For best results, the pipeline to be tested needs to be free of any these environmental conditions.

Calibration

The laser profiling equipment requires calibration for possible distortion prior to use as well as during the inspection process. The calibration process varies dependent upon the system that is selected. One system is calibrated under controlled conditions in a laboratory prior use on a project. The calibration involves the use of proving rings of a known dimension. Furthermore, the calibration is specific to the camera equipment that will be utilized with the laser profiler. Another system conducts calibration in the field which is typically done outdoors at the project site. This field calibration involves the videoing of a rod of known length which is at the same position that the laser head would be. The field calibration is susceptible to environmental factors that may result from the calibration being conducted in a non-controlled environment. This can lead to issues with data interpretation and error and ultimately accurate repeatability of data.

Equipment Limitations

The laser profiling equipment varies between manufacturers. Some of the differences can contribute to inaccurate measurements of the pipe and negatively impact the data. For one technology, the laser is coupled to the laser camera via a metal rod. The placement of the metal rod creates a blind spot at the invert where the laser intersects the bar such that approximately seven percent of the pipe interior is not addressed by the profiling. For the second technology, the pipe is inspected with a low distortion video camera first. A laser projector on a sled is attached to the camera via a chain. The video equipment is pulled backwards towing the laser profile sled and the video camera records the image of the laser. Since the camera and the laser profiler sled are on separate pieces of equipment attached with a chain, they are free to move independently of each other. This process is not only time consuming since two independent reviews of the pipe are done but can also lead to variability in the results. Since the equipment is on two separate frames, the profiling will be based on the relative positions of the equipment which can vary based on speed and the interior of the pipe. Additionally, if there are any obstructions in the line, this will cause one of the two components to react differently than the other, further impacting the ability to achieve reliable results. Operator interpretation of the data can lead to further variability in the results. One method to address this is to have the laser and camera on the same frame which fixes the location of the two and helps to eliminate relational errors.

Data Analysis

Final results from the laser profiling inspection are based on analysis of the data. This is especially applicable for some laser profiling systems where there is debris or water in the line that needs to be accounted for. Analysis can take up to two weeks to complete which may create delays in the overall project schedule. Some systems are attempting to implement a wireless component for data transmission to expedite delivery of information and expedite the overall schedule. However, this will still be project specific. Regardless of the system that is selected, the data analysis and report delivery timeframe needs to be evaluated and compared against the overall project schedule to ensure that excessive delays are avoided.

Summary

The use of laser profiling is a relatively new technology. The technology is extremely interesting and allows for the collection of a large amount of data. However, accurate, repeatable results are limited at this time due to pipe condition, environmental factors, operator interpretation and equipment limitations as discussed above. Although the technology is promising, it is still developing. As a result, the technology is still under evaluation and has not been approved for wide use by any major national approval body.

¹ *Refining Laser Profiling Methods Used for Pipeline Assessment*, Trenchless Technology Center, Louisiana Tech University, Ruston, Louisiana, April, 2005.



Technical Note

TN 5.09 Thermoplastic Pipe and Utility Crossings

Introduction

Underground utilities include storm sewer, electric, sanitary sewer, gas, water, telephone and cable. Utility conflicts are typically avoided during the design process. However, in some cases, existing utilities are not properly identified or located during the design process. In other instances, the location of the utility is known, but adequate construction controls are not in place. Both can result in a negative impact to an existing utility when installing a new utility. The purpose of this Technical Note is to provide additional information on the impact of utility crossings. While the discussion centers on the use of thermoplastic (high density polyethylene, HDPE and polypropylene, PP, specifically) pipe, there are documented cases of all types of pipes being affected, and in some cases damaged, by subsequent utility activity nearby.

Design Considerations

Many issues associated with utility disturbances can be avoided during the design process. The design will depend on the type of utility that is installed which may also dictate the depth. Typically, sanitary sewers are buried the deepest and located outside the roadway section. Water lines are generally the next deepest utility and usually are placed a minimum of 5 feet horizontally from sanitary sewers to prevent contamination. Some municipalities locate sanitary and water utilities on opposite sides of the roadway to minimize the potential for disturbance and contamination. Gas, electric and telephone utilities are generally located outside the pavement section on one side of the street in a utility corridor and are usually shallower than water and sanitary utilities. Storm sewer depth can be shallow depending on the terrain and outlet locations. Storm sewers can be located in the roadway or parallel to the roadway. The associated outfalls and area drains can be located outside the right of way in an easement. Since storm sewers are gravity flow drainage, their depth can vary more than other utilities. Most municipalities have ordinances or standards on utility locations and separate distances to minimize and prevent conflicts.

Excavation Considerations

For most municipalities, a statewide one-call utility location system is in place to locate the presence of existing utilities. It is extremely important in the case of electrical, gas and high-pressure water lines that contractors exercise care to avoid cutting these utilities, as the results can be catastrophic, even fatal. Although not catastrophic, the cutting of sanitary and storm sewers can cause maintenance and flooding concerns.

Construction organizations typically recommend that a utility survey be conducted prior to construction activities. The utility survey is conducted to accurately locate all existing (active and abandoned) utilities within the area of interest that could conflict with the planned construction. The Engineer, using records and drawings from various utility owners as a starting point, may conduct the survey. It is advisable to use specialty underground survey firms to confirm the locations and characteristics of the utilities shown on the drawings. It is especially important to search for abandoned utilities and note their locations and characteristics.⁽¹⁾

Once construction begins, the type of equipment that is utilized can have an impact on the potential for utility damage. The use of traditional excavation equipment, such as backhoes or excavators, is very common for the installation of utilities. The use of traditional equipment can provide the best opportunity to locate an existing utility that has not been previously identified. This type of equipment can damage all pipe types if contacted. However, it also offers the operator the opportunity to periodically inspect the excavation for signs of existing utilities. The location of an existing utility location can often be identified before it is impacted by excavation equipment.

Trenching equipment is common for a small diameter pipe or cable installation and can be designed specifically for rock installations. This equipment is operated continuously with little opportunity for inspection of the excavation for other utilities. Lastly, the equipment operates at a very high decibel level further impeding the operator's ability to determine if an existing utility has been encountered. As a result, the use of trenching equipment can impact all pipe types with little to no awareness by the operator.

Directional boring or drilling is being used more frequently for the installation of utilities. It is a steerable [trenchless](#) method of installing utilities along a prescribed subsurface bore path by using a surface launched drilling rig, with minimal impact on the surrounding area. Directional boring is used when excavating or trenching is not practical. The technique has been used extensively in urban areas as it eliminates the need for open cut trenches. To be successful, the operator must have thorough knowledge of existing utilities so that he can plan alignment and avoid damaging those utilities. In the case of small diameter utility installation, it is difficult to identify the nature and type of underground obstructions. Furthermore, certain directional equipment is designed to bore through rock and can operate at pressures of up to 30,000 psi. In this instance, an underground utility, regardless of material of construction, would be negatively impacted. Since uncontrolled drillings can lead to such damages, various agencies/government authorities owning the urban 'right-of-way' or the utilities that have authority over underground installations have formed their own rules for safe work execution when using this technology.

The other installation procedure that can have an impact to an existing utility are those that entail "driving" an object from the surface. This typically applies to fencepost or guard rail. In this application, the operator needs to be fully aware of subsurface utilities. The equipment involved with this installation can operate with enough force to damage an underground utility regardless of pipe type. As a result, equipment manufacturers of this type recommend that all underground utilities be properly located so as to avoid potential damage to those utilities.

Installation Considerations

The preferable method of thermoplastic pipe storm sewer installation is to prepare a suitable trench or embankment installation in accordance with recommended depths, widths, soil types and compaction levels. When working adjacent to existing utilities, appropriate pipe spacing needs to be maintained to ensure the stability of the trench and the overall long term performance of the thermoplastic pipe storm sewer. The required pipe spacing will depend on pipe diameter, pipe depth and backfill type.

In some cases, the proximity of an existing utility prevents the use of traditional backfill materials due to lack of adequate clearance for compaction to occur. In this case, controlled low strength material (CLSM) or flowable fill is an appropriate alternative. This is a low strength (120 psi) material that when installed, does not require any compactive effort. Due to its consistency, the material is self forming and self compacting. However, when it dries, it forms an encasement type backfill material that can be excavated if necessary. The use of flowable fill still requires a certain minimum distance between utilities to provide the necessary structural support. As with traditional backfill, this will depend on pipe diameter and pipe depth.

In situations in which a utility crosses too closely or comes in contact with a HDPE or PP storm sewer, CLSM may not be sufficient to provide the necessary structural support. For this condition, concrete encasement is recommended.

Slope/Soil Considerations

Effects of adjacent excavation and response of pipe materials are issues of soil stability until the excavation encroaches on the pipe embedment zone. The long term performance characteristics of any pipe material can be compromised in cases where slope failure occurs. If the pipe is within the failure plane, it will most likely be impacted as a result of the slope failure. The potential for this situation increases as the depth of the installation increases. If an installation was deep enough to cause concerns regarding slope stability and possible failure, it is likely that OSHA regulations would require shoring, trench box or another protective system. For trench installation, Federal regulations mandate an adequate protective system be required at depths greater than five feet ⁽²⁾ and some state safety codes reduce this limit to four feet. The use of a protective system would limit the impact of an adjacent installation on an existing utility regardless of pipe material.

For installations that occur beneath existing HDPE or PP pipe, exposure of pipe or loss of material must be avoided. Typically, if a minimum of 12 inches of stable, compacted material is maintained between the existing thermoplastic pipe and the proposed utility, the thermoplastic pipe will have adequate structural support. There are several options available for installations of this type. In order to address the specific site conditions, please contact and ADS representative for additional information on this type of installation.

When dealing with slope/soil stability while excavating next to an existing utility, the most extreme circumstance that can occur is slope failure resulting in exposure of the existing pipe. The complete exposure of the sidewall of a buried HDPE or PP pipe should and can be avoided with proper installation procedures, utility corridors, shoring etc. Long term exposure of this type should be avoided for any material and is not specific to thermoplastics. The exposed condition should be corrected and the pipe returned to a backfilled condition as soon as possible. To avoid long term performance issues, the exposed pipe should be backfilled to conditions equal to or better than the original installation. To avoid uncertainty, an agency may prescribe CLSM material be used when existing pipe is exposed.

Methods of Identifying Utilities

Certain construction practices can be helpful in preventing damage by subsequent utility installation. These include but are not limited to:

Backfill Materials

Using a select backfill can alert the operator of the possibility of a utility before it is impacted. A stone or sand backfill in areas where native soils are clayey or silty could be used in this case. It should be noted that the use of such material is strictly for utility location and not for structural purposes and can apply to all pipe material types.

Locator Tape

Locator tape is an inexpensive way to notify an operator of a utility. Placing locator tape above the pipe trench would notify the operator of a utility conflict prior to damaging the pipe. Figure 1 provides two examples of the application of locator tape for a utility installation.

Figure 1
Use of Locator Tape with Underground Utilities

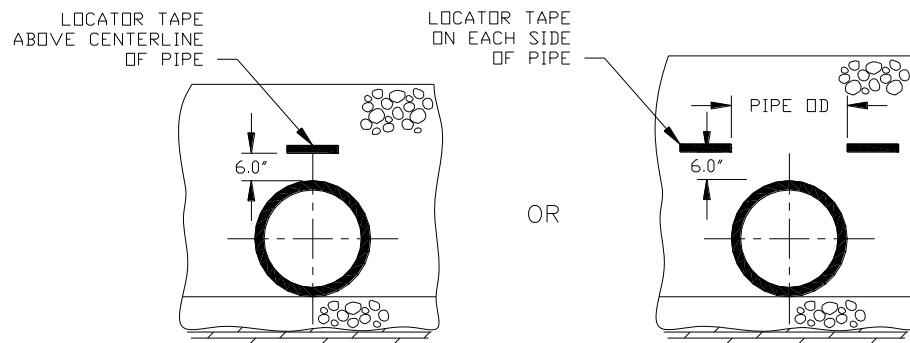

Ordinances

The most effective way of preventing utility cuts is to enforce ordinances for the phasing and spacing of utility locations as discussed previously. Furthermore, the ordinances need to be worded such that individual utility contractors are responsible for damages they create. Some agencies have enforced their ordinances by requiring utility contractors to repair utility cuts within a specified time frame after the damage is identified or the agency will do the repair and charge the utility contractor. It may also be necessary to prescribe standards for re-establishing backfill conditions if the pipe envelope of an existing utility is compromised.

Repair of Utility Cuts for HDPE & PP Pipe

One of the many benefits of HDPE and PP pipe is the ability to easily repair damage. The type of repair will depend on the nature and extent of the damage. Repair will typically fall into one of three categories which are discussed further below. More specific information on repair methods can be found in Technical Note 5.03 *HDPE Pipe Repair Options*, Technical Note 5.12 *HP STORM Drainage Pipe Repair Options*, Technical Note 5.13 *SaniTite HP Repair Options*.

Split Couplers

For relatively small utility cuts (3-4" long cuts perpendicular to the centerline of the pipe), repairs can be made by uncovering the damaged section and placing a split coupler over it. The split coupler can then be backfilled in place covering the damaged portion of pipe. This can be enhanced by wrapping the repair with fabric. Another option in lieu of a split coupler is a Mar-Mac® Polyseal coupler. A Mar-Mac coupler should be used when repairing triple wall pipe and a soil-tight joint is allowed by project specifications.

Pipe Sections

For larger utility cuts (greater than 4" along the pipe axis) the damaged section can be uncovered and removed to a point where there is no longer any damage. The cuts should be made in the valleys of the corrugations (Figure 2) and a new section of pipe cut to length and joined to the existing pipe with split couplers (Figure 3). The split coupler can be enhanced by wrapping the repair with fabric. Another option in lieu of a split coupler with fabric is the use of a Mar-Mac Polyseal coupler. A Mar-Mac coupler should be used when repairing triple wall pipe and a soil-tight joint is allowed by project specifications.

Figure 2
Pipe Cut Location



Figure 3
Split Band Installation



Internal Seals

For small utility cuts (3-4" long holes), it is often economical to seal the pipe internally. Several commercially available internal seals are available. Internal seals use polyisoprene rubber membranes that are secured to the inside of the pipe with expanding stainless steel bands. Generally, internal seals are only appropriate for larger diameter (24" or greater) pipes since internal access is necessary. Additional information can be found in the repair method technical notes for the respective ADS pipe product.

Conclusions

All pipe types are susceptible to damage from the installation of adjacent utilities. Damage can be prevented during the design phase with proper utility location and phasing or during the construction phase with proper utility location. If utility location is not exact, further damage can be minimized through the selection of installation equipment and the use of trench boxes or shoring. Furthermore, in the event that HDPE or PP pipe is physically damaged during the construction process, repair is relatively simple and inexpensive.

Footnotes

¹ Chapter 4 – Planning, Horizontal Directional Drilling, Good Practices and Guidelines, Horizontal Directional Drilling Consortium, 2004

² 29 CFR 1926.652(a).



Technical Note

TN 5.10 Integral Bell Transition for HDPE Pipe

ADS offers a variety of joints to the market place. Corrugated HDPE pipe can be cut at any corrugation allowing a great degree of flexibility in making field cuts. Plain end pipe can be connected using split couplers, cleated bell-bell couplers, or bell end couplers and gaskets. The standard pipe joint ADS offers is the Integral Bell (IB) joint which requires field cuts when transitioning to plain end pipe, fittings or other materials.

ADS N-12[®] IB pipe has an integral bell which maintains a constant pipe outside diameter (OD). This constant OD eliminates the need for bell holes and makes it easier to maintain line and grade during installation. The gasketed bell and spigot design, with an elastomeric rubber gasket meeting ASTM F477, is intended for soil-tight (ST) or watertight (WT), gravity-flow storm sewer applications, as defined in ASTM F 2306 and ASTM D 3212..

Connections for Integral Bell Pipe

With the variety of couplers available, connecting to existing pipe runs or to fabricated fittings may necessitate a transition to other ADS joints. ADS fittings come as either plain end or bell end; which makes it necessary to transition from an IB joint to either a plain end connection or a bell end connection. This technical note will give guidance in selecting the proper method of making these connections.

Integral Bell Pipe to Plain End Pipe (12" – 60") (Plain End Pipe/Fitting Connections)

Remove the bell or spigot end of the pipe. The spigot end on 12"-60" pipe will have mini or reduced-size corrugations; for smaller diameter pipe, 4"-10", there will be no mini corrugations to remove. Utilize a split coupler or cleated bell-bell coupler (snap coupler) to make the connection. Refer to Figure 1 for common configurations. This connection is considered soil-tight in most embedment soil conditions.

Figure 1
Integral Bell Pipe to Plain End Pipe Connection

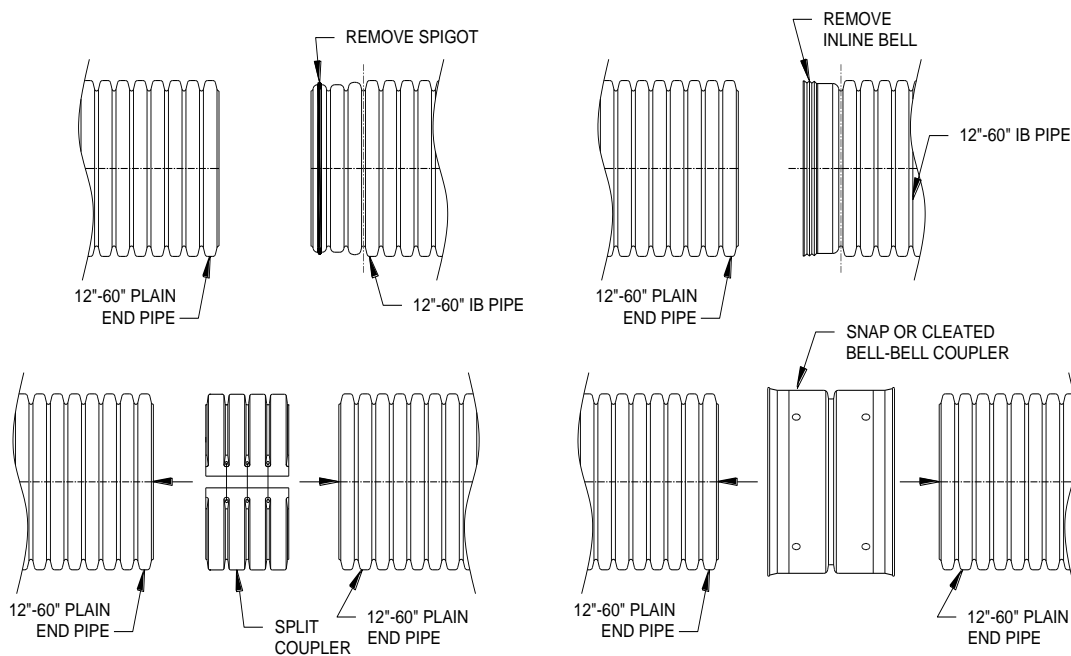

Integral Bell Pipe to a Welded Bell (Welded Bell End Pipe/Fitting Connections)

To connect pipe or fittings, which already have a welded bell, remove the mini corrugations from the spigot end of pipe or the IB bell from the bell end. The welded bell can be identified easily compared to the integral bell, because a weld seam will be present where the bell and corrugations meet. In addition to the weld seam, the OD of the welded bell is slightly larger than the OD of the adjacent corrugations. Refer to the pictures in Figure 2. Once the mini corrugations or IB bell have been removed, install a valley gasket (12"-36") or saddle gasket (42"-60") provided by ADS. Valley gaskets are to be placed in the valley behind the first corrugation crown. Saddle gaskets are placed on the crown of the first corrugation. Lettering printed on the gasket will face the joining bell. Lube gasket and the inside of the welded bell, be sure to lube the bells leading edge, and insert the spigot into the welded bell. This connection is considered soil-tight or watertight based on the type of gasket used. Consult an ADS representative to ensure the correct gasket is ordered to meet connection performance requirements.

Figure 2
Welded Bell Connection

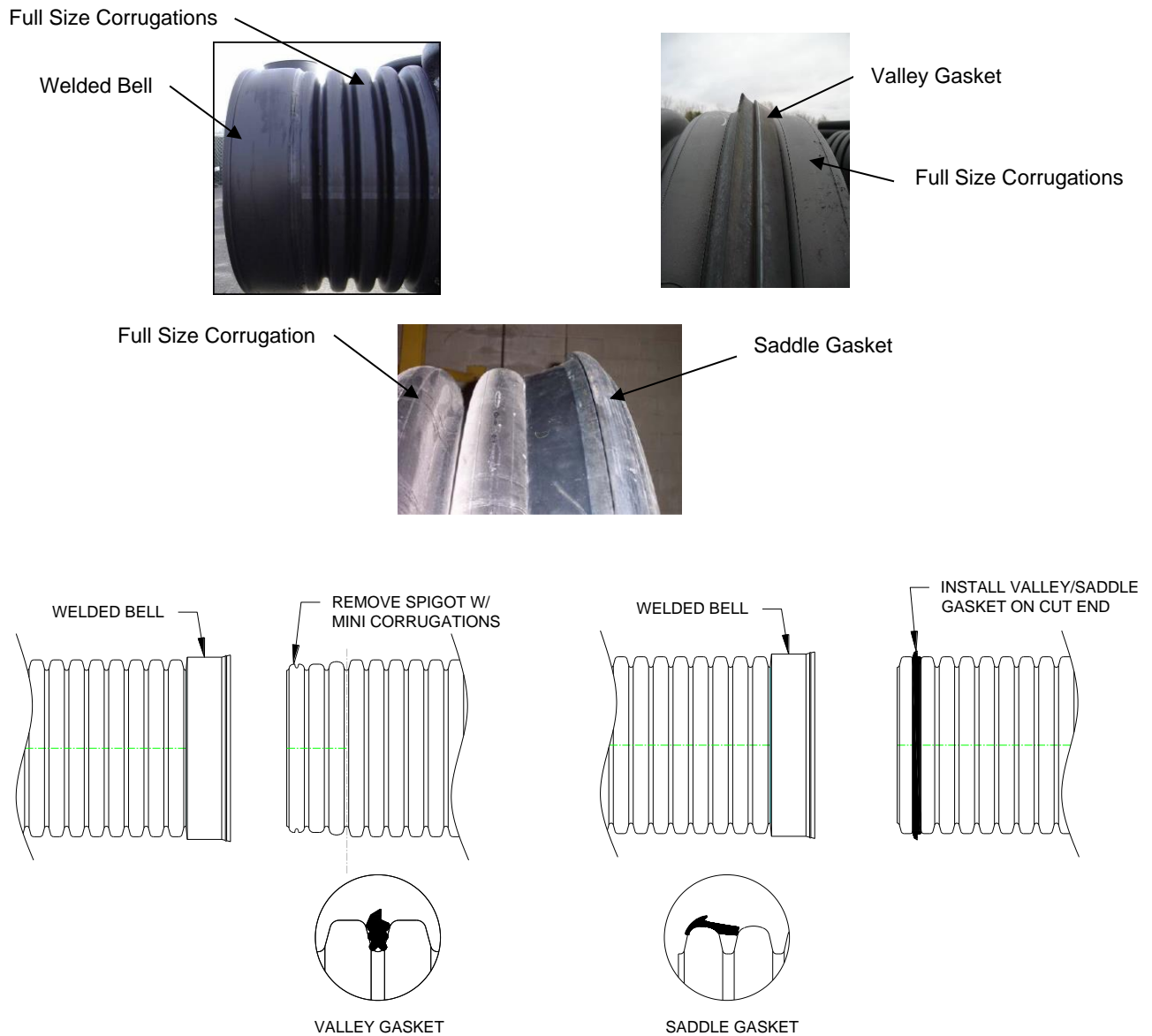

Integral Bell Pipe to Bell-Bell Coupler Connection

Some field modification will require the use of a bell-bell coupler in conjunction with a valley or saddle gasket. This field joint configuration follows very similarly to that described above for welded bell pipe/fitting connections. Remove the inline bell, spigot and/or the appropriate number of corrugations needed to make the connection and install a valley gasket (12"-36") or saddle gasket (42"-60") provided by ADS. Valley gaskets are to be placed in the valley behind the first corrugation crown. Saddle gaskets are placed on the crown of the first corrugation. Lettering printed on the gasket will face the joining bell. The joint will now consist of two pipes/fitting which each have a valley or saddle gasket installed as shown in Figure 3. Lubricate the interior and leading edge of a bell-bell coupler and the valley/saddle gaskets. Connect the pipes by inserting the valley/saddle gasket end of the pipes into the bell-bell coupler. This connection is considered soil-tight or watertight based on the type of gasket used. Consult an ADS representative to ensure the correct bell-bell coupler with accompanying gasket is ordered to meet connection performance requirements. If a non-gasketed connection is allowed, a split coupler or cleated bell-bell coupler (snap coupler) can be used in place of the bell-bell coupler for a soil-tight joint.

Figure 3
Bell-Bell Coupler Connection

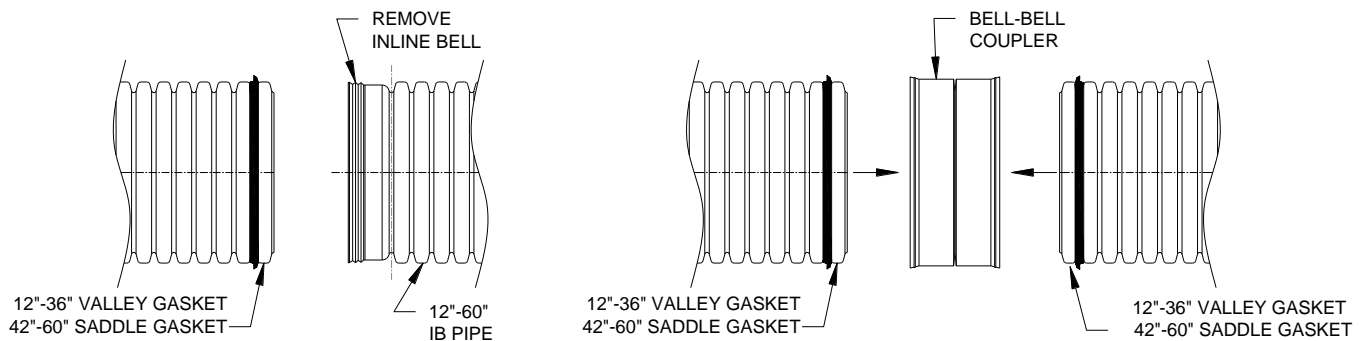

Vent Tube Sealing

The manufacturing process of corrugated plastic pipe requires the release of hot air from inside the corrugations in order to properly form the corrugations. This hot air is allowed to escape from the corrugations during the extrusion process via vent tubes that run the length of the pipe. Vent tubes become exposed when the pipe is cut in the field to install a fitting, connect to a manhole, or otherwise adjust the length of a pipe run. Exposed vent tubes may result in a leak path, and therefore is recommended that they be sealed. It is important that these vent tubes be sealed whenever the pipe is cut in the field. Please see Technical Note 5.16: *Methods for Sealing Vent Tubes* for instructions on sealing the vent tubes.



Technical Note

TN 5.11 Sliplining Extended Lengths with HDPE Pipe

ADS offers a variety of joints to the marketplace. HP pipe products are manufactured using polypropylene resin and is available in 12" through 60" with exterior corrugations (dual wall), while 30" through 60" may also be available with an exterior shell (triple wall). The HP products are also available for storm and sanitary sewer markets. Additional information regarding each of the products available from ADS can be found in Technical Note 1.05: *Pipe Joints and Gaskets*. While HP pipe can be cut in the field, the connection method must be based on the allowable joint performance for the project.

ADS HP pipe products have an integral bell which maintains a constant pipe outside diameter (OD). This constant OD eliminates the need for bell holes and makes it easier to maintain line and grade during installation. The bell and spigot design for HP products, with an elastomeric rubber gasket meeting ASTM F477, meets or exceeds the watertight testing requirements outlined in ASTM D 3212.

Connections for HP Pipe

With the variety of couplers available, connecting to an existing pipe run or a fabricated fitting may necessitate a transition to other ADS joints. ADS fittings come standard with a plain end, welded bell end or IB bell or spigot end; the end treatment will be based on fitting diameter and available configurations are available in the ADS Fittings Manual. Standard large diameter or custom fittings utilizing IB joints require no additional field work for the connection.

Integral Bell Pipe to Plain End Pipe (12" – 60") (Plain End Pipe/Fitting Connections) *Storm Drainage Only as specifications permit*

Remove the bell or spigot end of the pipe. The spigot end on 12"-60" pipe will have mini or reduced-size corrugations. To achieve a **soil-tight** joint, a split band coupler may be utilized to connect 12" - 60" dual wall pipe and a Mar-Mac® coupler may be utilized to connect 12" - 60" dual or triple wall (where applicable) pipe. Refer to Figure 1 for common configurations.

Figure 1
HP Integral Bell Pipe to Plain End Pipe Connection

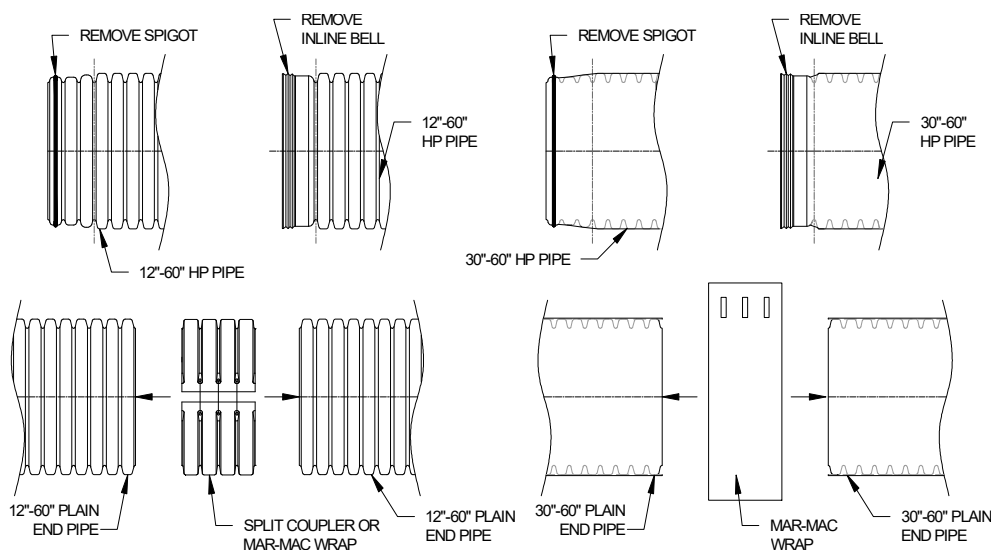

Integral Bell Pipe to a Welded Bell (12" – 24") (Welded Bell End Pipe/Fitting Connections)

To connect dual wall pipe or dual wall fittings that already have a welded bell, remove the mini corrugations from the spigot end or the integral bell from the pipe. The welded bell can be identified easily compared to the integral bell, because a weld seam will be present where the bell and corrugations meet. In addition to the weld seam, the OD of the welded bell is slightly larger than the OD of the adjacent corrugations. Refer to the pictures in Figure 2. Once the mini corrugations or integral bell has been removed, install a valley gasket (12"-24") provided by ADS. Valley gaskets are to be placed in the valley behind the first corrugation crown. Lettering printed on the gasket will face the joining bell. Lube gasket and the inside of the welded bell, being sure to lube the bell's leading edge, and insert the spigot into the welded bell. This connection is considered watertight in accordance with ASTM D3212 when using an ADS watertight valley gasket. Consult an ADS representative to ensure the correct gasket is ordered to meet connection performance requirements. For watertight connections for 30" – 60" triple wall pipe, please contact an ADS representative for currently available options.

Figure 2
Welded Bell Connection

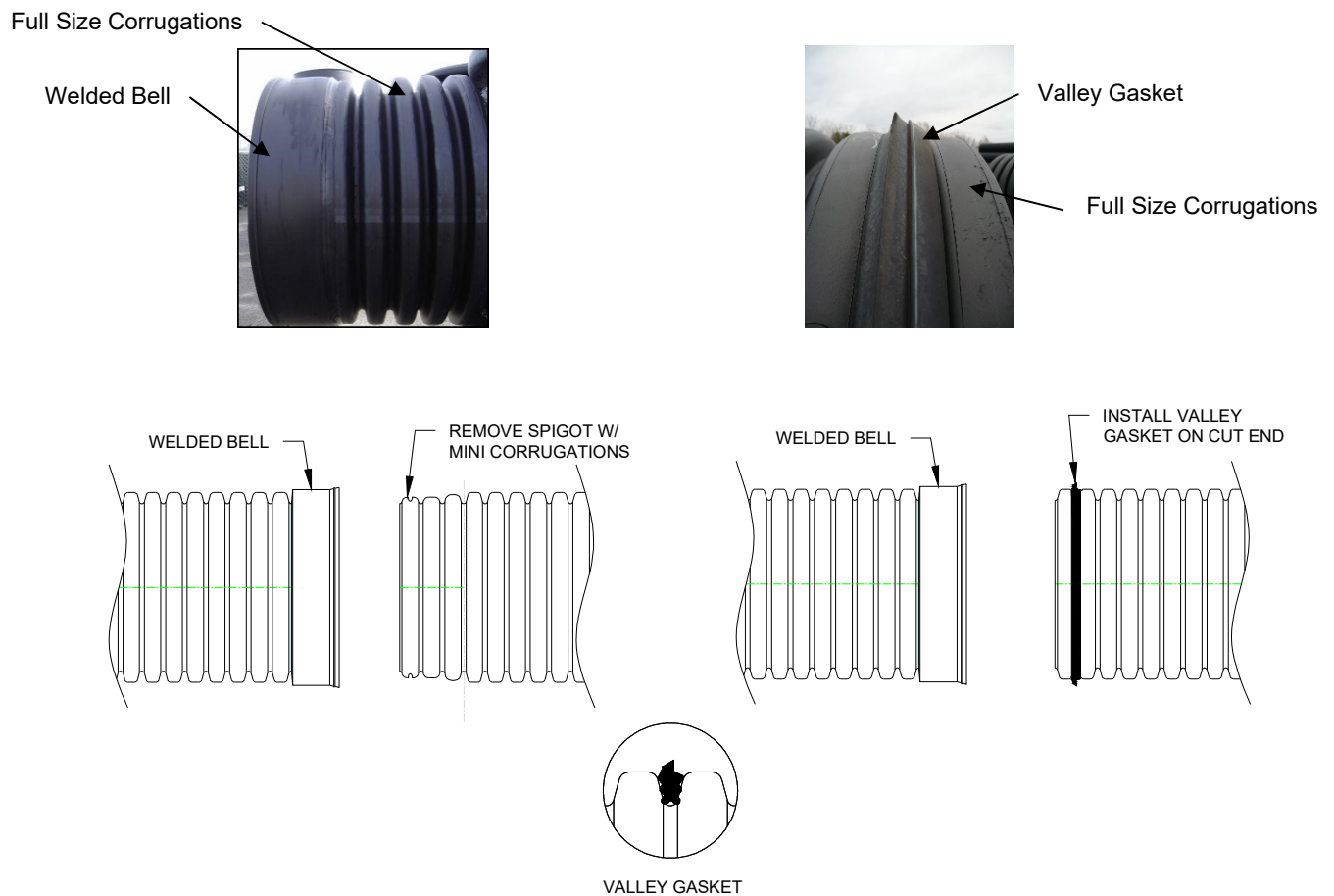

Integral Bell Pipe to Bell-Bell Coupler Connection (12" – 24")

Some field modifications for 12" through 24" pipe will require the use of a bell-bell coupler in conjunction with a valley gasket. This field joint configuration follows very similarly to that described above for welded bell pipe/fitting connections. Remove the inline bell, spigot and/or the appropriate number of corrugations needed to make the connection and install a valley gasket (12"-24") provided by ADS. Valley gaskets are to be placed in the valley behind the first corrugation crown. Lettering printed on the gasket will face the joining bell. The joint will now consist of two pipes/fitting which each have a valley gasket installed, as shown in Figure 3. Lubricate the interior leading edge of a bell-bell coupler and the valley gaskets. Connect the pipes by inserting the valley gasket end of the pipes into the bell-bell coupler. This connection is considered watertight in accordance with ASTM D3212, provided an ADS watertight valley gasket used. Consult an ADS representative to ensure the correct bell-bell coupler with accompanying gasket is ordered to meet connection performance requirements. For watertight connections for 30" – 60" triple wall pipe, please contact an ADS representative for currently available options.

Figure 3
Bell-Bell Coupler Connection

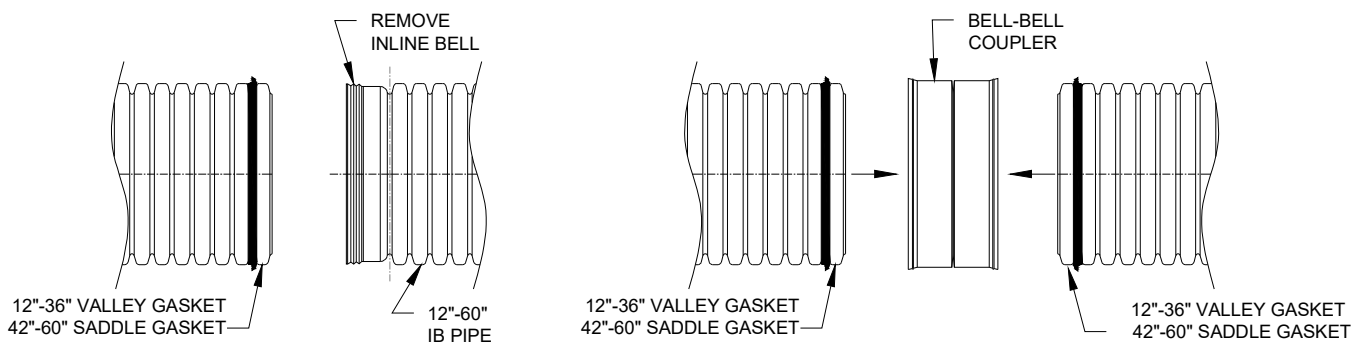

Vent Tube Sealing

The manufacturing process of corrugated plastic pipe requires the release of hot air from inside the corrugations in order to properly form the corrugations. This hot air is allowed to escape from the corrugations during the extrusion process via vent tubes that run the length of the pipe. Vent tubes become exposed when the pipe is cut in the field to install a fitting, connect to a manhole, or otherwise adjust the length of a pipe run. Exposed vent tubes may result in a leak path, and therefore is recommended that they be sealed. It is important that these vent tubes, when present, be sealed whenever the pipe is cut in the field. Please see Technical Note 5.16: *Methods for Sealing Vent Tubes* for instructions on sealing the vent tube.



Technical Note

TN 5.12 HP Storm Drainage Pipe Repair Options

Introduction

ADS HP STORM for storm drainage is made of polypropylene (PP) resin making the pipe lightweight and very easy to handle. The attributes that make the pipe easy to use can also make it easy to abuse, resulting in damaged pipe or joints. This technical note discusses some of the products available that can be used to repair damaged PP pipe or joints in the field.

Repair Options

One of the primary considerations in selecting a repair method is the degree of joint performance required. Watertight repairs are generally used on pipe with watertight joints, and soil-tight repairs on pipe with soil-tight joints. This helps keep costs in line and prevents the repair from being the weak area of the pipe system.

The way in which a pipe can be accessed is another primary consideration which influences what type of repair alternative is selected. Pipe that is not yet buried, or can be easily excavated, can be repaired from the exterior. If the pipe is buried and cannot be conveniently excavated, an internal repair may be the best alternative. If the pipe is too small to enter, there are companies with remote controlled equipment that can install the product. Each situation must be considered individually.

The repair options addressed below are divided into external repairs and internal repairs. During any pipe repair, backfill should be placed and compacted per project specifications to provide proper support for the pipe and coupler.

External Mechanical Repairs

Mar Mac Polyseal Pipe Coupler, 12- through 60-inch (300 - 1500 mm), consists of a mastic adhesive base layer, a cross-laminated polyethylene middle layer with a spun-bonded geotextile polypropylene cloth outer layer. The coupler incorporates self-adhering rubberized bonding mastic and securing bands to insure a positive seal around the pipe. If the pipe itself is damaged, the damaged area will need to be removed and a new pipe section spliced in before installing a coupler around both ends. Polyseal Pipe Couplers are reasonably priced, especially when considering the quality of the finished repair, and are typically used with soil-tight smooth interior thermoplastic pipe products. *Note: Mar-Mac bands shall be installed in accordance with manufacturer's recommendations.*

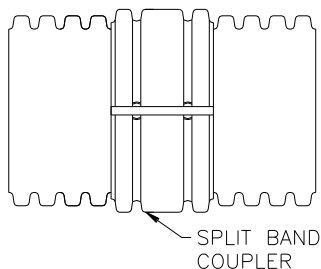

Split band couplers, 12- through 60-inch (300 – 1500 mm), will provide a soil-tight repair with or without gaskets. Split band couplers engage the exterior corrugations and therefore can only be used for corrugated exterior pipe. This repair method should only be used if the damaged area is in a non-trafficked green area, is cosmetic in nature, confined to a single corrugation, and is not defined as structural damage. The coupler shall be centered over the damaged area of pipe and tightened down with the nylon straps. If the damaged area is large or significant, the damaged area is to be cut out, and replaced with a new section of pipe. The replacement section is to be 'spliced' in place using split band couplers. They are a convenient, low-cost repair alternative, and are typically used to repair soil-tight thermoplastic pipe products with a corrugated exterior.

Concrete collars also provide a soil-tight repair, dependent on the integrity of the installation. Installing a concrete collar involves building a form around the area to be repaired and encasing it in concrete. A geotextile is usually wrapped around the repair area prior to pouring the collar to keep the concrete from seeping into the pipe. Typically, approximately 6" (0.15m) is excavated beneath the pipe to allow for proper application of the geotextile and concrete encasement. If the pipe itself is damaged, the damaged area shall be removed and a replacement pipe section spliced in prior to pouring the collar. In order to provide a greater level of joint performance, a gasket can be installed on the pipe in the concrete encasement. Concrete collars are typically more costly and time consuming than snap couplers or split band couplers but are reasonable repair options for soil-tight smooth interior thermoplastic pipe products. .

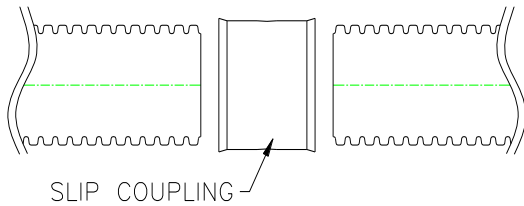
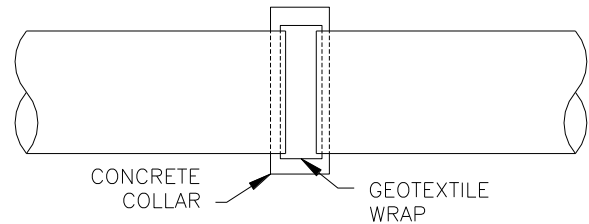

Slip Couplings 12- through 30-inch (300 – 750 mm), provides a watertight repair that will meet most pressure testing requirements, when installed correctly. The slip coupling uses PVC bells with gaskets. The gaskets are placed in the valleys on either side of the section to be repaired and slip couplings are then slid over the gaskets. Due to the exterior gasket, the slip coupling can only be used on pipe with a corrugated exterior. PVC slip couplings are most commonly used with watertight smooth interior, corrugated exterior thermoplastic pipe products.

Large Diameter Repair Coupler 12- through 60-inch (300 – 1500 mm) are ideal for repairs and alterations of large diameter pipe. Repair couplers similar to those provided by Mission Rubber Company LLC, Fernco® or equal may be used on HP Storm pipe. The couplers are used by removing the damaged section of pipe, replacing it with a new section and then sliding the coupler back around the joint, similar to the slip coupling above. The couplers stainless steel bands are then tightened to the manufactures recommendations. These rubber couplings are capable of meeting watertight field test requirements when installed per manufacturer's recommendations.

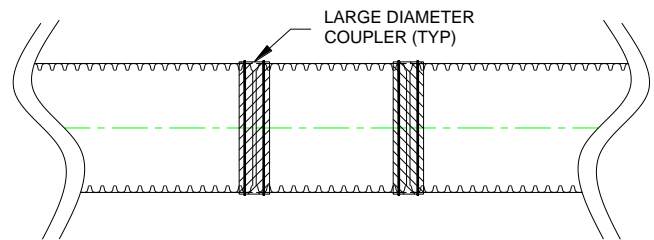

Internal Repairs

Internal mechanical repair products generally consist of a flexible cylindrical gasket sleeve, which is expanded to conform to the inner wall of the pipe. The feasibility of this repair method depends on the size of the damaged section or joint and available access into the pipe. Internal mechanical seals slightly restrict the inside diameter of the pipe. This should be considered when assessing the risk of debris obstruction.

NPC Internal Joint Seal, 18- through 60-inch (450 – 1500 mm), consists of an EPDM rubber seal and stainless steel bands. The rubber seal is inserted into the pipe and positioned over the joint. A torque wrench is used to expand the bands against the inner wall of the pipe. The Internal Joint Seal is designed to seal joints – not repair damaged pipe sections. The damaged area of the pipe must be removed and a replacement section spliced in if necessary in order to use the Internal Joint Seal. This system may provide a watertight joint when installed as recommended.

The manufacture should be contacted to verify the product meets the specific application requirements including test requirements, if specified. If pressure tests are required, NPC should be contacted to ensure that the product is suitable for the specific test criteria.

Internal mechanical seals will slightly restrict the inside diameter of the pipe. This should be considered when assessing the risk of debris obstruction.

Link Pipe Grouting Sleeve™, 12- through 60-inch (100 – 1500 mm), is a stainless steel grouting sleeve that is installed with an inflatable plug. The sleeve may be used to seal a joint or repair short sections of damaged pipe. The manufacture should be contacted to verify the product meets the specific application requirements including test requirements, if specified.

Internal chemical sealing is another method of internal joint repair using chemically activated gel or grout to minimize joint leakage. The grout is typically applied with specialized remote-controlled equipment. Test/seal packer is used to remotely seal a joint. The grouting chemicals are forced through the joint out into the surrounding soil where they gel with the soil. The gelled mass forms a waterproof collar around the pipe. The result is significantly reduced leakage. There are several types of chemical grouts available and the manufacturer should be contacted to review the specific situation and any joint tightness or pressure test criteria. Companies such as Avanti International, Strata Tech Inc., and Carylton Corporation manufacture and/or install chemical grout. Stephen's Technologies *New Life Coatings* and *NewLife Liner Systems* as well as Avast Hydro-Lining International, are examples of companies that offer cured in place epoxy lining systems that have been effectively used with HDPE pipe. Most pipe diameters can be chemically grouted provided the grouting contractor has the appropriate equipment.

Manufacturer Contact Information

Contact the Regional Engineer or Application Engineering Department for assistance with other unique conditions or for contact information regarding any companies listed in this technical note.

Note: Thermoplastic pipe products are solely intended for the conveyance of fluids. Access into this product for maintenance, inspection, repair, or other reason should be done in strict accordance with OSHA recommendations for confined space entry.



Technical Note

TN 5.14 Culvert Sliplining with HP Pipe

Introduction

It may be at times necessary, in an aging infrastructure, to rehabilitate drainage and sanitary lines by lining them with a new pipe. An abrasive or corrosive environment can cause premature deterioration of some types of pipe. In lieu of a total replacement, sliplining the existing pipe with a durable material may be an economical method to significantly extend the service life. N-12® HP pipe made with polypropylene (PP), is often the product of choice to slipline deteriorated pipes because of its resistance to aggressive environments. For installations where HP STORM or SaniTite HP will be inserted into a newly placed casing pipe, refer to Technical Note 5.18 *Lining of Casings with SaniTite HP* for relevant information.

Access to the Host Pipe

The “host” pipe may be open on both ends, as in a culvert application, or it may be accessible only through a manhole opening, as in a storm or sanitary sewer applications. An HP product may only be used in applications in which the pipe is installed in such a way that the pipe is not bent during installation.

Diameter of the Host Pipe

The greater of either the outside diameter of the liner pipe or coupler should be compared to the inside diameter of the host pipe. This may be accomplished by attempting to pull a short section (~2 feet in length) through the host pipe as a trial run. The host pipe should be free from sediment and debris so as to not interfere with the installation of the liner pipe. Sliplining installations may be subject to thermal length changes and should be designed with a minimum of 10% clearance between the pipe’s outside diameter and the host pipe’s inside diameter. It is important to have adequate clearance between the host pipe and the carrier pipe for installation and eventual grouting measures. The maximum outside diameters of HP pipe products are shown in Table 1.

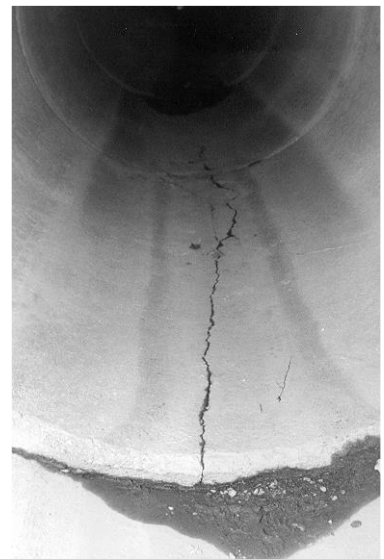

Table 1
Dimensions of HP Pipe Products

Nominal Inside Diam. in (mm)	Max Outside Diam.* in (mm)	Nominal Inside Diam. in (mm)	Max Outside Diam.* in (mm)
12 (300)	14.6 (371)	36 (900)	41.4 (1052)
15 (375)	17.8 (452)	42 (1050)	47.5 (1206)
18 (450)	21.4 (544)	48 (1200)	53.9 (1369)
24 (600)	28.2 (716)	60 (1500)	66.6 (1692)
30 (750)	35.7 (907)		

* Contact ADS for additional guidance if anticipated OD values provided may not provide adequate clearance.

Length of Installation

HP pipe joints are not designed to withstand large pulling forces. It is also important not to damage pipe ends while pushing the liner pipe in through the host pipe. The method of installation will affect, in large part, the maximum length that can be slip lined without damaging the pipe. Using skids, especially in a corrugated host pipe, will help minimize resistance between the two surfaces and allow for longer installations. A push-and-pull technique keeps stress on the joints to a minimum. Maximum pushing forces listed in Table 2 shall be adhered to.

Table 2
Maximum Push Force on HP Products

Nominal Inside Diam. in (mm)	Max Force Pounds (kN)	Nominal Inside Diam. in (mm)	Max Force Pounds (kN)
12 (300)	1500 (6.7)	36 (900)	9000 (40.0)
15 (375)	2000 (8.9)	42 (1050)	11000 (48.9)
18 (450)	3000 (13.3)	48 (1200)	12000 (53.4)
24 (600)	4500 (20.0)	60 (1500)	16000 (71.2)
30 (750)	4500 (20.0)		

Hydraulic Considerations

In situations where one is lining an existing pipe, careful evaluation of the current and desired hydraulics should be accomplished. Original design calculations may be referenced; however careful attention should be given to changes in land use which would change the calculated runoff tributary to the culvert. Once a discharge has been determined, the required size of the pipe may be established. If original design calculations are not available, the project engineer should complete a thorough drainage study. A culvert size can be selected based on watershed attributes, design storm, allowable headwater, culvert entrance conditions and any other related design factors.

In many cases, where culverts are too deep to make replacement practical, slightly reduced hydraulics may be an acceptable tradeoff to an expensive replacement. Typically, gravity flow systems are designed using Manning's Equation with an 'n' value of 0.012 for HP products. It should be noted that culverts in need of relining do not have Manning's 'n' values typical of original design values. Relining with smooth interior HP pipe may actually increase the capacity of the deteriorated culvert.

Structural Requirements

Failing culverts in need of relining may eventually deteriorate into a conduit with no structural integrity at all. For this reason, it is important to reline with a pipe product capable of handling the loads based on expected loading conditions and assuming no load reduction from the host pipe. Loading for highway and pavement tunnels shall be based upon a continuous load carrying structure for the height of cover under HS-25 loading. Voids between the surrounding soil and the host pipe shall be pressure grouted to ensure structural integrity and resistance to thermal effects. For more information for determining the structural capacity of HP pipe, refer to the *Structures* section of the *Drainage Handbook*.

Installation of HP Storm in Host Pipe

Before the pipe is inserted into an existing culvert for relining, it is critical to inspect the existing culvert for any objects or obstructions, which may be extending into the barrel of the existing culvert to be relined. Failure to do this may result in a damaged liner pipe.

In applications where the host pipe or culvert is deteriorated, flat boards or skids shall be affixed to the culvert or the lining pipe to allow the lining pipe a suitable base to slide on. Skids can be as simple as 2x4's and it is common to place these skids in the lower haunch areas approximately 90 degrees apart, as shown in Figure 1. Typically 2 to 4 skids are used around the pipe. It is important that the skids be notched at the strap location in order to provide a smooth sliding surface.

Figure 1
Attachment of Skids to HP Pipe

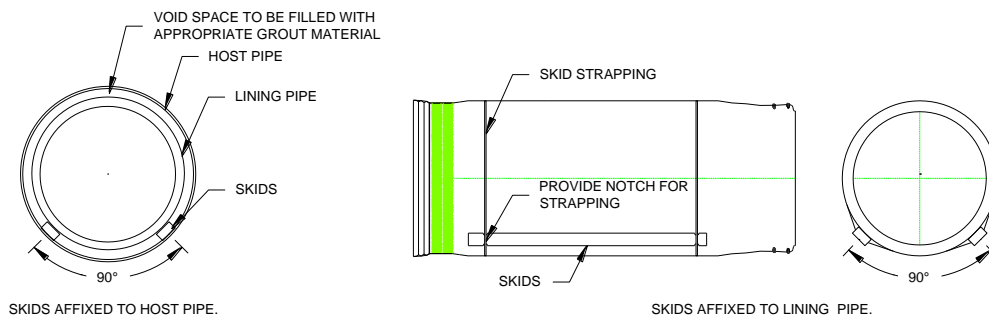

Insertion Forces

Once the culvert or casing is clear, the new material may be pushed through. It is important to not exceed the maximum insertion force that can be applied to the lining or carrier pipe, as provided in Table 2. This will prevent the pipe joints from over insertion. For lengths of pipe that surpass these recommend forces, see the next section on “Sanitary Sewer Casings” or contact a local representative.

In cases where the new culvert will be two or more nominal diameters smaller than the existing culvert, it is possible to construct mechanisms to transport the new culvert along the existing culvert without sliding across the invert. Although ideal for construction, many times there is insufficient room to allow for this technique.

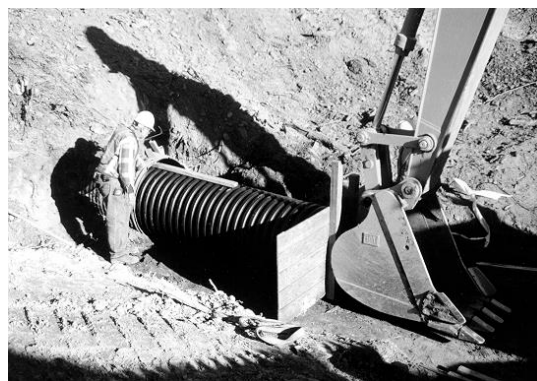

Grouting Procedures

When relining a culvert with HP pipe, it is recommended to fill the void space between the existing culvert and the lining pipe with grout material. The grout material is often a controlled low strength material (CLSM), also referred to as controlled density fill, CDF, or flowable fill. CLSM will help provide uniform support on the sides of the pipe, maintain a consistent soil density, provide lateral support for the pipe, and eliminate point loads. For more information on flowable fill mix, refer to Technical Note 5.02: *Flowable Fill Backfill for Thermoplastic Pipe*.



It is common for aging metal culverts to have deteriorated or completely destroyed inverts. This allows the fluid carried through the culvert to create void space under the pipe, creating an undesired condition. The grout material will help plug and fill any fractures or holes in the existing culvert along with structurally stabilizing the system from thermal effects, hydrostatic pressure, point loads, and function as a water barrier.

To ensure proper alignment and prevent joint separation, the pipe should be anchored against flotation when placing the grout material. Grouting in layers thin enough, such that they don't float the pipe, helps tremendously

Each layer should be allowed to set up between pours. Contractors may have other techniques that will also prevent flotation such as the use of deadweight inside the pipe. Regardless of the method used, it is also important to avoid applying point loads to the pipe. For more information on flotation and anchoring methods, refer to Technical Note 5.05: *Pipe Flotation*.

When HP pipe, or any flexible pipe, is used as a liner, it is very important not to use excessive grout pressure. In most circumstances, the joint, not the wall strength, will be the limiting factor for establishing a maximum allowable grouting pressure. Including a factor of safety, the recommended maximum grouting pressure for HP pipe products is 5 psi; this value may vary based on specific site conditions and specific products used. During the grouting operation, gauges should be used to monitor the grout pressure exerted on the pipe system. For some applications, hydrostatic head pressure may increase the expected pressure on the pipe from the grouting. Additional pressure may also result from the slope and/or diameter of the pipe, elevation changes between the pipe and the gauge, and other conditions that should be considered during the design. The sum of all pressures that will be exerted on the pipe should not exceed the recommended maximum pressure for the application.



Technical Note

TN 5.15 Integral Bell Transition for HP Pipe Products

ADS offers a variety of joints to the marketplace. HP pipe products are manufactured using polypropylene resin and is available in 12" through 60" with exterior corrugations (dual wall), while 30" through 60" may also be available with an exterior shell (triple wall). The HP products are also available for storm and sanitary sewer markets. Additional information regarding each of the products available from ADS can be found in Technical Note 1.05: *Pipe Joints and Gaskets*. While HP pipe can be cut in the field, the connection method must be based on the allowable joint performance for the project.

ADS HP pipe products have an integral bell which maintains a constant pipe outside diameter (OD). This constant OD eliminates the need for bell holes and makes it easier to maintain line and grade during installation. The bell and spigot design for HP products, with an elastomeric rubber gasket meeting ASTM F477, meets or exceeds the watertight testing requirements outlined in ASTM D 3212

Connections for HP Pipe

With the variety of couplers available, connecting to an existing pipe run or a fabricated fitting may necessitate a transition to other ADS joints. ADS fittings come standard with a plain end, welded bell end or IB bell or spigot end; the end treatment will be based on fitting diameter and available configurations are available in the ADS Fittings Manual. Standard large diameter or custom fittings utilizing IB joints require no additional field work for the connection.

Integral Bell Pipe to Plain End Pipe (12" – 60") (Plain End Pipe/Fitting Connections) *Storm Drainage Only as specifications permit*

Remove the bell or spigot end of the pipe. The spigot end on 12"-60" pipe will have mini or reduced-size corrugations. To achieve a **soil-tight** joint, a split band coupler may be utilized to connect 12" - 60" dual wall pipe and a Mar-Mac® coupler may be utilized to connect 12" - 60" dual or triple wall (where applicable) pipe. Refer to Figure 1 for common configurations.

Figure 1
HP Integral Bell Pipe to Plain End Pipe Connection

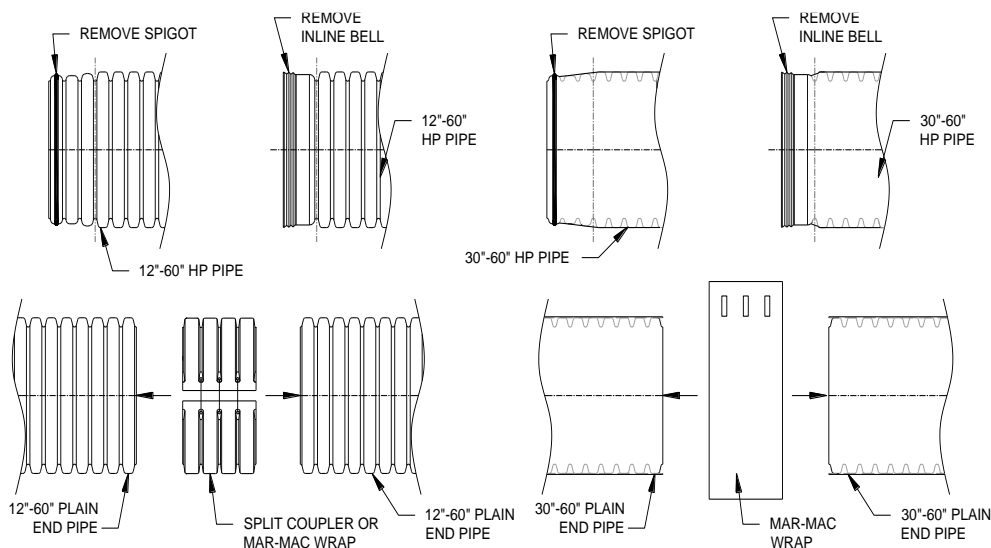

Integral Bell Pipe to a Welded Bell (12" – 24") (Welded Bell End Pipe/Fitting Connections)

To connect dual wall pipe or dual wall fittings that already have a welded bell, remove the mini corrugations from the spigot end or the integral bell from the pipe. The welded bell can be identified easily compared to the integral bell, because a weld seam will be present where the bell and corrugations meet. In addition to the weld seam, the OD of the welded bell is slightly larger than the OD of the adjacent corrugations. Refer to the pictures in Figure 2. Once the mini corrugations or integral bell has been removed, install a valley gasket (12"-24") provided by ADS. Valley gaskets are to be placed in the valley behind the first corrugation crown. Lettering printed on the gasket will face the joining bell. Lube gasket and the inside of the welded bell, being sure to lube the bell's leading edge, and insert the spigot into the welded bell. This connection is considered watertight in accordance with ASTM D3212 when using an ADS watertight valley gasket. Consult an ADS representative to ensure the correct gasket is ordered to meet connection performance requirements. For watertight connections for 30" – 60" triple wall pipe, please contact an ADS representative for currently available options.

Figure 2
Welded Bell Connection

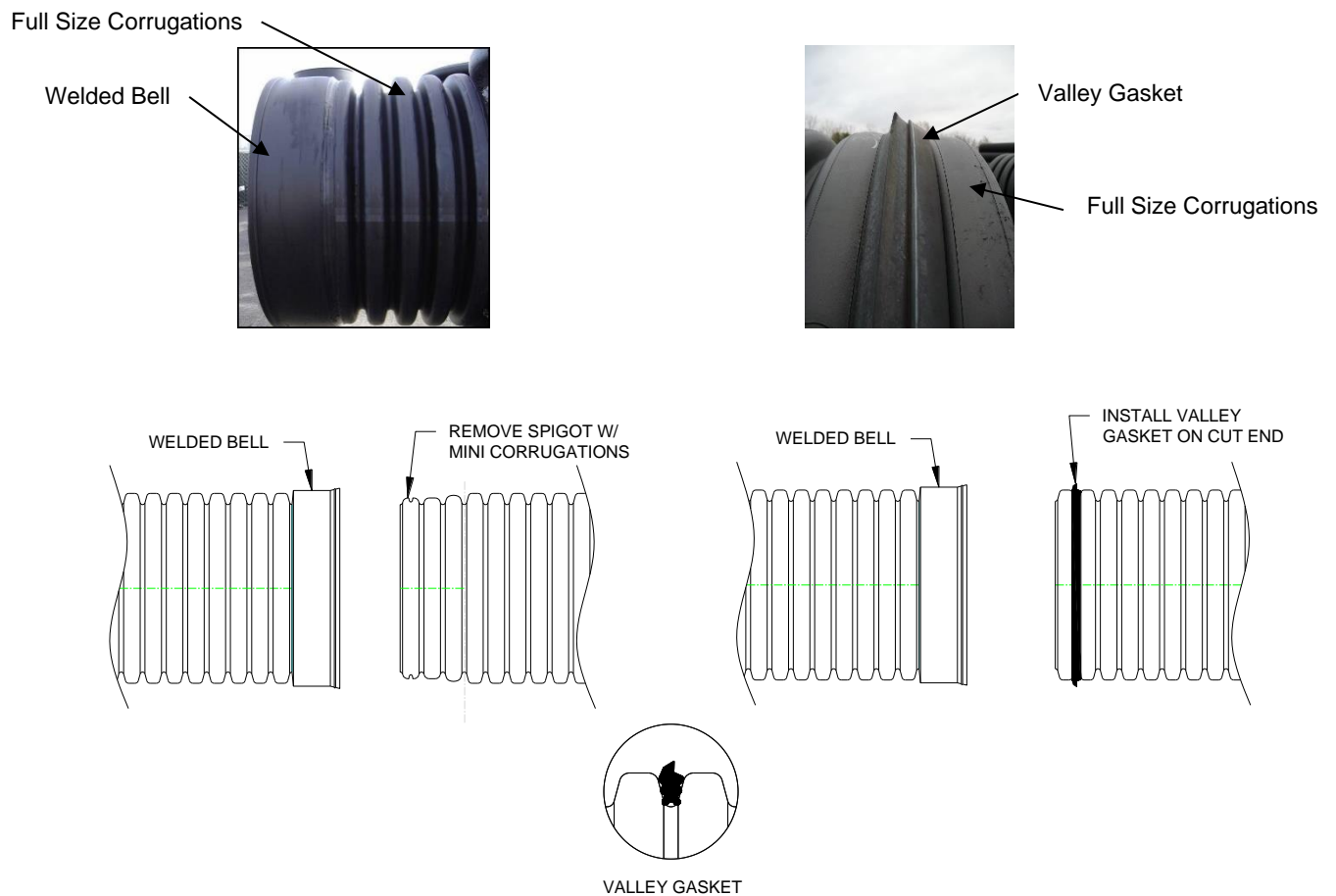

Integral Bell Pipe to Bell-Bell Coupler Connection (12" – 24")

Some field modifications for 12" through 24" pipe will require the use of a bell-bell coupler in conjunction with a valley gasket. This field joint configuration follows very similarly to that described above for welded bell pipe/fitting connections. Remove the inline bell, spigot and/or the appropriate number of corrugations needed to make the connection and install a valley gasket (12"-24") provided by ADS. Valley gaskets are to be placed in the valley behind the first corrugation crown. Lettering printed on the gasket will face the joining bell. The joint will now consist of two pipes/fitting which each have a valley gasket installed, as shown in Figure 3. Lubricate the interior leading edge of a bell-bell coupler and the valley gaskets. Connect the pipes by inserting the valley gasket end of the pipes into the bell-bell coupler. This connection is considered watertight in accordance with ASTM D3212, provided an ADS watertight valley gasket used. Consult an ADS representative to ensure the correct bell-bell coupler with accompanying gasket is ordered to meet connection performance requirements. For watertight connections for 30" – 60" triple wall pipe, please contact an ADS representative for currently available options.

Figure 3
Bell-Bell Coupler Connection

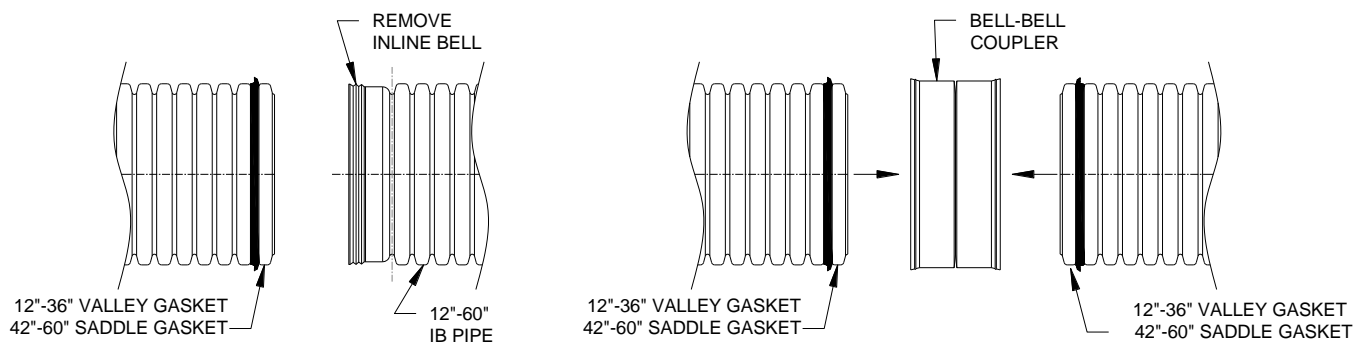

Vent Tube Sealing

The manufacturing process of corrugated plastic pipe requires the release of hot air from inside the corrugations in order to properly form the corrugations. This hot air is allowed to escape from the corrugations during the extrusion process via vent tubes that run the length of the pipe. Vent tubes become exposed when the pipe is cut in the field to install a fitting, connect to a manhole, or otherwise adjust the length of a pipe run. Exposed vent tubes may result in a leak path, and therefore is recommended that they be sealed. It is important that these vent tubes, when present, be sealed whenever the pipe is cut in the field. Please see Technical Note 5.16: *Methods for Sealing Vent Tubes* for instructions on sealing the vent tube.



Technical Note

TN 5.16 Methods for Sealing Vent Tubes

Introduction

The manufacturing process of corrugated plastic pipe requires the release of hot air from inside the corrugations in order to properly form the corrugations. This hot air is allowed to escape from the corrugations during the extrusion process via vent tubes that run the length of the pipe. Vent tubes become exposed when the pipe is cut in the field to install a fitting, connect to a manhole, or otherwise adjust the length of a pipe run. Exposed vent tubes may result in a leak path, and therefore it is recommended that they be sealed. It should be noted that internal cuts or exposed vent tubes are not structural concerns and the requirement to seal them depends on site conditions and project specifications. A variety of methods can be used to seal vent tubes. This technical note will discuss two methods, spin welding and chemical adhesives.

Spin Welding Vent Plugs

Spin welding is a technique that can be used to seal vent tubes. The spin welding method utilizes the heat produced by friction to create a weld between the pipe and a vent plug.

To create a quality weld, the plug and the pipe must be the same material. Plugs made of either polyethylene or polypropylene are to be used (see Figure 1). They are designed with a shank that fits into a drill, and they also have multiple sealing segments to accommodate different vent tube sizes. The vent plugs are sold kits for the different pipe materials. Table 1 shows the vent plug kits.

Table 1: Vent Plug Kits

Kit Number	Pipe Sizes	Vent Plugs in Kit			Minimum Vent Tube Diameter	Maximum Vent Tube Diameter
		Part Number	Material	Quantity		
1260VPPPK	12 through 60-inch	1260VPPP	Polypropylene	10	3/16-inch	7/8-inch
1260VPPEK	12 through 60-inch	1260VPPP	Polyethylene	10	3/16-inch	7/8-inch

Tools Required

Tools required for installation are a standard drill and drill bit. The drill should be set to its highest speed and it must be able to reach a **minimum of 1500rpm**. If using a cordless drill, it should have a fully charged battery. A drill bit will only be necessary in a case where the vent tube diameter is smaller than the minimum diameter from Table 1 above. If the vent tube diameter is too small, it will need to be drilled to the correct size.

Installation Instructions

1. The pipe **must** be cut directly in the center of the valley between corrugations (see Figure 2). Failure to do this will result in a vent hole opening that cannot be welded shut with the spin welding method (see Figure 3).
2. Ensure that the diameter of the vent tube meets the minimum requirement from Table 1.
3. If the vent tube diameter is large enough, skip to step 5. If the vent tube diameter is too small (see Figure 4), drill out the vent tube using a drill bit that corresponds to the minimum vent tube diameter from Table 1 (see Figure 5).
4. Manually lock a vent plug into the drill chuck so that the entire shank is held by the chuck (see Figure 6). Do **not** lock the plug into the drill under power.
5. With the power off, position the tip of the plug into the vent tube, and then start the drill.
6. With the drill at its highest speed, put slight pressure on the drill to begin inserting the plug into the vent tube (see Figure 7).
7. Continue letting the drill spin, and the plug will gradually push into the vent tube. It should take about 30-seconds to complete a weld. Reduce pressure on the drill if the plug appears to be inserting into the pipe too quickly.
8. When the vent plug appears to have been inserted enough to completely seal the vent tube, continue spinning the vent plug to the next larger segment. Stop the drill when this segment is flush with the pipe (see Figure 8), and **hold the drill in place for no less than 20-seconds to allow the weld area to cool.**

Figure 1: Vent Plugs

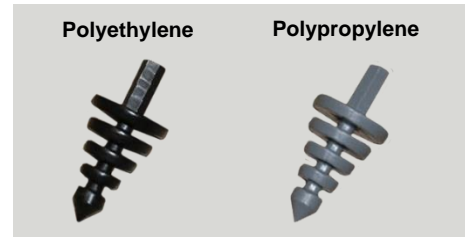

Figure 2: Cutting the Pipe



Figure 3: Incorrectly Cut Pipe



Figure 4: Small Vent Tube



Figure 5: Drilling Vent Tube



Figure 6: Chucked Vent Plug



Figure 7: Spin Welding



Figure 8: Holding Drill Flush



9. After the weld has cooled, squeeze the trigger of the drill again. If a quality weld was created, the shank of the spin plug will shear off (see Figure 9).
10. Release the trigger and manually un-chuck the plug shank.
11. If necessary, the welded area can be cleaned up with a sureform tool or similar scraping device (see Figure 10).
12. Visually inspect the weld, and check for looseness.
13. Repeat steps 2 through 12 for each exposed vent tube.

Figure 9: Sheared Shank



Figure 10: Finishing the Weld



Sealing Vent Tubes with Chemical Adhesives

Another method of sealing vent tubes is by using a chemical adhesive along with polyolefin material. This approach requires a specially designed 2-part adhesive, applicator gun and polyolefin material in the shape of small discs. This method can be more cumbersome and expensive than the aforementioned procedure, but may be used when spin welding is no longer an option, as may be the case with a very large vent tube.

1. Prepare the area to be sealed by first lightly scuffing and removing any small flakes of plastic with the use of a medium grade sand paper or round file.
2. Using acetone or Isopropyl alcohol, thoroughly clean the area to be bonded of any dirt, grease, or foreign debris and allow the area to fully dry prior to applying epoxy.



- Using an epoxy suitable for PP bonding (3M® Scotch-Weld Acrylic Structural Plastic Adhesive DP-8005 or other approved adhesive), liberally coat a small area around the hole and thoroughly fill the hole with epoxy. A HDPE or PP disk or chip should be placed over the hole and “glued” or bonded with the epoxy to serve as the sealing mechanism.



- Following all application and cure times as provided by the epoxy manufacturer, a second coat of epoxy may be applied where necessary.



- Allow to set for 3 hours or as recommended by the epoxy manufacturer before joining to another pipe or disturbing the area which has just been sealed. Temperature and humidity may effect set time. The long-term integrity of the seal is dependent on the quality of the materials and the sealing technique.

Manufacturer Contact Information

ADS cannot anticipate all unique situations encountered on specific installations; however, several common repair methods are addressed in this text. Contact an ADS representative for answers to other unique conditions or for contact information regarding any companies listed in this technical bulletin.



The ADS logo and the Green Stripe are registered trademarks of Advanced Drainage Systems, Inc.
© 2022 Advanced Drainage Systems, Inc. TN 5.16 May 2022

adspipe.com

1-800-821-6710

Technical Note

TN 5.20 Post Installation Testing of HP Storm

Introduction

Storm sewer is often tested after or during installation to ensure a sound installation was accomplished. Types of post installation field testing include deflection testing and joint testing. Specific testing required for the project will be found in the project specifications. This technical note is not meant to supersede any project specification, but should be used in conjunction with the project specification and national testing standards as it relates specifically to HP Storm pipe.

Deflection Testing

An important feature of any flexible pipe is its ability to deflect, or oval, under load without structural distress. Deflection allows the load to be transferred from the pipe to the surrounding backfill. The result is flexible pipe can withstand very high loads as a relatively light structure. Flexible pipe – including HP Storm – *must* deflect in order to mobilize the strength of the surrounding backfill.

According to current thermoplastic design procedures, deflection is defined as a service limit. The designer, considering all site conditions, will set this service limit in order to perform a proper design evaluation. Deflection in excess of this service limit does not necessarily result in strength limits being exceeded, i.e. system failure. For more information on service and strength limit states, see the *Structures* section of the Drainage Handbook. HP Storm can be expected to perform satisfactorily in most applications with 5% or 7.5% deflection and so it is typical of designers to choose a service limit in this range.

When testing for allowable deflection limits, the minimum inside diameter should be used when establishing mandrel sizing. The minimum inside diameter accounts for the allowable manufacturing tolerances. Table 1 lists the inside diameters that result from 5% and 7.5% deflection from the minimum inside diameter. Values listed in Table 1 should be used for sizing mandrels for deflection testing. Mandrels may be obtained from a variety of commercial suppliers.

Table 1
HP Storm Recommended Mandrel Settings

Pipe Type	Pipe Diameter	Minimum Inside Diameter*	Inside Diameter with 5% Deflection	Inside Diameter with 7.5% Deflection
Dual Wall	12	11.88	11.29	10.99
	15	14.85	14.11	13.74
	18	17.82	16.93	16.48
	24	23.76	22.57	21.98
	30	29.70	28.22	27.47
	36	35.64	33.86	32.97
	42	41.58	39.50	38.46
	48	47.52	45.14	43.96
	60	59.40	56.43	54.95

* Value is the larger of ASTM F2881 and AASHTO M330. If designing to a specific standard, please review allowable minimum diameter

It is important to understand that mandrel testing is a go/no-go test. If any line were to not pass a mandrel, it is important to ascertain the cause. Obstructions in the line, not associated with deflection, may influence the test. Visual inspection is recommended in the event of a no-go result.

Joint Testing

Joint testing is an important part of any gravity sewer system, both in testing for infiltration and exfiltration. Infiltration aids to estimate the amount of sewer water that will be conveyed to, and ultimately treated by, the waste water treatment plant. Exfiltration aids to estimate the loss of sewage water into the surrounding soil. The two primary ways of testing sewer pipe joints for infiltration and/or exfiltration is using air or water to create a constant pressure within the system.

Exfiltration Testing with Air

Air is a compressible gas and so it is extremely important one adheres to the appropriate safety regulations outlined in OSHA and project specifications. There are two primary national testing standards that may be applied to joint testing HP Storm: ASTM F1417 *Standard Test Method for Installation Acceptance of Plastic Gravity Sewer Lines Using Low-Pressure Air*, and ASTM F3058 *Preliminary Field Testing of Thermoplastic Pipe Joints for Gravity Flow (Non-Pressure) Sewer Lines*. When either standard is specified by the project plans, one should review the standards carefully and follow the testing procedure and safety precautions outlined. The below commentary on the ASTM testing procedures should be considered a summary and does not replace the testing procedures outlined in their respective specifications.

ASTM F1417 entails testing a run of pipe from one manhole to the next adjacent manhole. Inflatable plugs are positioned into the manholes and secured. Air is introduced into the pipe line and gradually builds pressure. Once the line has been pressurized and is stable at 4.0-psi, the pressure is decreased to 3.5-psi at which time the line must not lose more than 0.5- or 1.0-psi (whichever is specified by the design engineer) in the specified amount of time. Table 2 below summarizes the minimum time that must be reached for less than 0.5- or 1.0-psi of pressure drop, depending on the diameter and length of pipe being tested.

Table 2
Time to Pressure Drop for HP Storm (per ASTM F1417)

Pipe Diameter	Pressure Drop (psi)	Minimum Test Time (min:sec)	Length for Minimum Time, (ft)	Time for Longer Lengths, (sec)	Time for Length Shown, (min:sec)							
					100 ft	150 ft	200 ft	250 ft	300 ft	350 ft	400 ft	450 ft
12	0.5	5:40	199	1.709 L	5:40	5:40	5:42	7:08	8:33	9:58	11:24	12:50
	1.0	11:20		3.418 L	11:20	11:20	11:24	14:15	17:05	19:56	22:47	25:38
15	0.5	7:05	159	2.671 L	7:05	7:05	8:54	11:08	13:21	15:35	17:48	20:02
	1.0	14:10		5.342 L	14:10	14:10	17:48	22:15	26:42	31:09	35:36	40:04
18	0.5	8:30	133	3.846 L	8:30	9:37	12:49	16:01	19:14	22:26	25:38	28:51
	1.0	17:00		7.692 L	17:00	19:13	25:38	32:03	38:27	44:52	51:16	57:41
24	0.5	11:20	99	6.837 L	11:24	17:57	22:48	28:30	34:11	39:53	45:35	51:17
	1.0	22:40		13.764 L	22:47	34:11	43:34	56:58	68:22	79:46	91:10	102:33
30	0.5	14:10	80	10.683 L	17:48	26:43	35:37	44:31	53:25	62:19	71:13	80:07
	1.0	28:20		21.366 L	35:37	53:25	71:13	89:02	106:50	124:38	142:26	160:15

Data taken from ASTM F 1417¹ and Uni-Bell, Uni-B-6-98³.

It may not be necessary to hold the test for the entire time period listed above when it is evident that the rate of air loss is zero or less than the allowable pressure drop and authorized by the approving authority¹.

When the pipe is large enough to be physically accessed, it may be desirable to test individual joints for safety reasons. In these cases, one may consider joint testing in accordance with ASTM F3058, also known as a joint isolation test. ADS recommends a joint isolation test, in lieu of a full line test, for testing pipe diameters 36" and larger for safety reasons. This test is typically done with air, though water may also be used, and involves the use of special testing equipment. The equipment consists of two inflatable bladders, placed on each side of the joint, creating an open center cavity between them. The bladders are inflated and then the center cavity is pressurized to 3.5 psi. The joint passes the test if the pressure is held for 5 seconds without dropping more than 1.0-psi. For all practical purposes, this is a go/no-go test. Final acceptance of the pipeline per this testing method shall be at the discretion of the Design Engineer. One advantage of this type of test is the ability for the installer to quickly test the joint immediately after installation, allowing for any corrective measures to be taken early on in the project.

Infiltration/Exfiltration with Water

Testing gravity sewer joints via water infiltration or exfiltration is a common practice. For HP Storm, this testing should be conducted in accordance with ASTM F2487 *Standard Practice for Infiltration and Exfiltration Acceptance Testing of Installed Corrugated High Density Polyethylene Pipelines*. These standards entail first observing the ground water conditions and, if applicable, measuring the infiltration rate of the ground water through the joints. If ground water is not applicable, then the line is filled with water and the leakage is observed through exfiltration.

Manholes shall be tested separately and independently of the pipe line to the requirements established in the project specifications. When water level is measured in the manhole for the exfiltration test, the leakage associated with the manhole shall be subtracted from the overall leakage of the test section to establish a pass or fail grade for the pipe.

Allowable Leakage

The allowable leakage rate for HP Storm is 100 gallons/in-dia/mi-pipe/day for both infiltration and exfiltration when done in accordance with ASTM F2487.

Conclusion

ADS HP Storm is intended for gravity flow storm sewer applications and may be tested for deflection and joint tightness as discussed in this technical document. It is important to note that the testing procedures are no different than for other storm sewer products currently being used in the market. This document does not purport to address the safety concerns associated with testing HP Storm. Any questions associated with testing HP Storm can be directed to your local representative.

References

1. ASTM F1417, *Standard Test Method for Installation Acceptance of Plastic Gravity Sewer Lines Using Low-Pressure Air*, ASTM, 2005
2. F3058, *Preliminary Field Testing of Thermoplastic Pipe Joints for Gravity Flow (non-Pressure) Sewer Lines*, ASTM, 2016.
3. ni-B-6-98, *Recommended Practice for Low-Pressure Air Testing of Installed Sewer Pipe*, Uni-Bell PVC Pipe Association, 1998
4. ASTM F2487, *Standard Practice for Infiltration and Exfiltration Acceptance Testing of Installed Corrugated High Density Polyethylene Pipelines*, ASTM, 2006
5. ASTM F2881, *Standard Specification for 12 to 60 in. (300 to 1500 mm) Polypropylene (PP) Dual Wall Pipe and Fittings for Non-Pressure Storm Sewer Applications*, ASTM, 2011



Technical Note

TN 6.01 Retention/Detention System Maintenance

This document is provided for informational purposes only and is meant only to be a guide. Individuals using this information should make their own decisions as to suitability of this guideline for their individual projects and adjust accordingly.

Introduction

A retention/detention system is comprised of a series of pipes and fittings that form an underground storage area, which retains or detains storm water runoff from a given area. As sediment and debris settle out of the detained stormwater, build up occurs that requires the system to be regularly inspected and cleaned in order for the system to perform as originally designed. The following provides the available fittings and guidelines for inspection and maintenance of an HDPE underground storage system.

System Accessories and Fittings

Concentric Reducers

Concentric Reducers are fittings that transition between two pipes, either in line with one another or at perpendicular angles. The centerlines of the two pipes are at the same elevation. When a concentric reducer is used to connect the manifold pipe to the lateral pipes, most debris will be trapped in the manifold pipe.

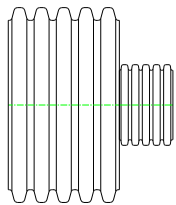

SIDE VIEW

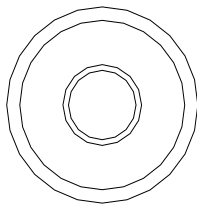

SECTION VIEW

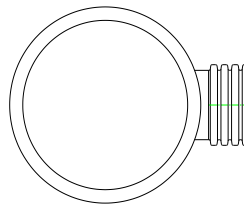

SIDE VIEW

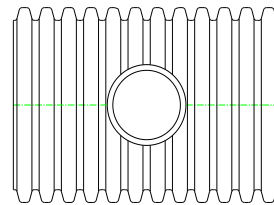

SECTION VIEW

Eccentric Reducers

Eccentric Reducers are fittings that transition between two pipes, either in line with one another or at perpendicular angles. The inverts of the two pipes are at the same elevations. When an eccentric reducer is used to connect the manifold pipe to the lateral pipes, most debris will follow the flow of the storm water into the lateral pipes.

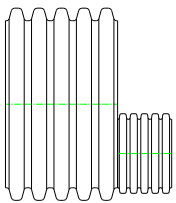

SIDE VIEW

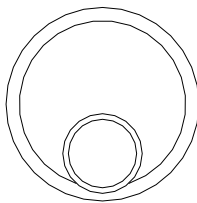

SECTION VIEW

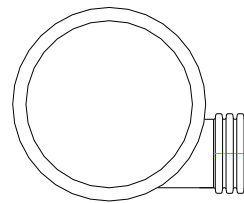

SIDE VIEW

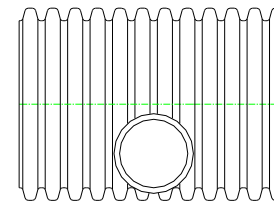

SECTION VIEW

Riser

Each retention/detention system typically has risers strategically placed for maintenance and inspection of the system. These risers are typically 24" in diameter or larger and are placed on the manifold fittings.

Cleanouts

Cleanout ports are usually 4-, 6-, or 8-in diameter pipe and are placed on the manifold fittings. They are used for entrance of a pipe from a vacuum truck or a water-jetting device.

For a complete listing of available fittings and components please refer to the *ADS Fittings Manual*.

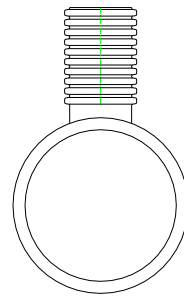

RISER
CROSS-SECTION VIEW

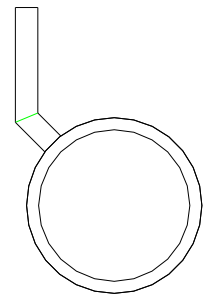

CLEANOUT
CROSS-SECTION VIEW

Maintenance Overview of a Retention/Detention System

Maintaining a clean and obstruction-free retention/detention system helps to ensure the system performs the intended function of the primary design. Build up of debris may obstruct flow through the laterals in a retention system or block the entranceway of the outlet pipe in a detention system. This may result in ineffective operation or complete failure of the system. Additionally, surrounding areas may potentially run the risk of damage due to flooding or other similar issues.

Inspection/Maintenance Frequency

All retention/detention systems must be cleaned and maintained. Underground systems may be maintained more cost effectively if these simple guidelines are followed. Inspection should be performed at a minimum of once per year. Cleaning should be done at the discretion of individuals responsible to maintain proper storage and flow. While maintenance can generally be performed year round, it should be scheduled during a relatively dry season.

Pre-Inspection

A post-installation inspection should be performed to allow the owner to measure the invert prior to accumulation of sediment. This survey will allow the monitoring of sediment build-up without requiring access to the retention/detention system.

The following is the recommended procedure for pre-inspections:

- 1) Locate the riser section or cleanouts of the retention/detention system. The riser will typically be 24" in diameter or larger and the cleanouts are usually 4", 6" or 8" in diameter.
- 2) Remove the lid of the riser or clean outs.
- 3) Insert a measuring device into the opening and make note to a point of reference on the stick or string. (This is done so that sediment build up can be determined in the future without having to enter the system.)

Inspection/Maintenance

A retention/detention system should be inspected at a minimum of one time a year or after major rain events if necessary.

The following is the recommended procedure to inspect system in service:

- 1) Locate the riser section of the retention/detention system. The riser will typically be 24" in diameter or larger.
- 2) Remove the lid from the riser.
- 3) Measure the sediment buildup at each riser and cleanout location. Only certified confined space entry personnel having appropriate equipment should be permitted to enter the retention/detention System.
- 4) Inspect each manifold, all laterals, and outlet pipes for sediment build up, obstructions, or other problems. Obstructions should be removed at this time.
- 5) If measured sediment build up is between 5% - 20% of the pipe diameter, cleaning should be considered; if sediment build up exceeds 20%, cleaning should be performed at the earliest opportunity. A thorough cleaning of the system (manifolds and laterals) shall be performed by either manual methods or by a vacuum truck.



Technical Note

TN 7.01 Rainwater Harvesting with HDPE Pipe Cisterns

Introduction

For the past several years, the use of smooth interior corrugated high density polyethylene (HDPE) pipe has been a viable alternative for the control of stormwater quality through underground systems. Typically, stormwater has either been infiltrated through perforated pipe or detained in solid pipe and then discharged at a controlled rate to the local storm sewer system or tributary. In both situations, the design did not provide for the potential reuse of stormwater. There is a growing demand for the construction industry to provide for resource reuse. In some situations, the reuse is being driven by a regulatory requirement. In many cases, the reuse of resources can provide an economic benefit. This is especially applicable to stormwater in areas where water resources are at a premium. Water reclamation should be considered in situations where infiltration is not feasible due to site constraints. This document provides information on the installation, storage capacity and system layouts for rainwater harvesting systems using ADS HDPE pipe cisterns.

HDPE Pipe Cisterns

ADS HDPE N-12 pipe is the building block of our cisterns. The Specifications section of the Drainage Handbook provides additional information on pipe dimensions and properties. The pipe has a smooth inner wall and a corrugated outer wall. The smooth inner wall combines superior hydraulics and the ability to resist abrasion and corrosion. The corrugated outer wall provides the strength necessary to withstand heavy traffic loads with varying cover heights. In addition to pipe, the ADS cistern uses specially designed manifolds and other fittings to complete the pipe component of the cistern. ADS can assist with system layout including pipe and necessary components for the cistern.

System Layout

A typical cistern layout includes at least one inlet into the system. This inlet can be on the cistern manifold as shown below or can be done on a lateral. Further, the inlet can be accomplished via a pre-fabricated stub or with a reducer and tee fittings in the system corner. Both inlet types are shown below. When designing system inlets, attention should be given to the hydraulic grade line of the site to limit or prevent conveyance system surcharging.

The outlet of the cistern should be directed to a reinforced concrete manhole. The manhole should be reinforced to limit the effects of vibration from the pump system. The outlet invert should be the same as the pipe invert elevation to ensure that the entire system is able to drain. An underdrain should be installed within the stone backfill of the cistern. The invert of the underdrain should be at the bottom of the stone backfill envelope. The underdrain from the stone backfill should be directed to the outlet manhole so that the stone backfill can be completely drained.

The outlet manhole serves multiple purposes. In addition to acting as an outlet structure, the manhole also houses a discharge pump (designed by others) to remove stormwater from the cistern. Installing a pump within the system piping or pumping directly from piping is not recommended for hydraulic reasons. The manhole should be located outside the footprint of the thermoplastic liner as shown in the detail below.

The outlet manhole will also include the cistern overflow. It is recommended that an overflow be incorporated into the system in the event that the cistern is not completely emptied between storm events. If the cistern is not completely empty and there is no overflow, the potential exists for the entire system to be surcharged and flooding could occur. The invert of the overflow should be set at the top of the cistern.

Lastly, the outlet manhole can also include a vent from the system. System venting is recommended to allow adequate airflow through the cistern and equalize air pressures within the cistern. If not vented, there can be issue with cistern pressures under some circumstances. In the sample layout shown below, the system includes a 4-inch HDPE vent line leading from the cistern to the outlet manhole. To prevent backflow into the cistern through the vent, it is recommended that the vent be located above the crown of the overflow pipe. The use of a vent is recommended for installations in which the cistern is encased within the thermoplastic liner. For cisterns that are not completely encased within the thermoplastic liner, the use of a vent is at the engineer's discretion.

Figure 1
Example Cistern Layout

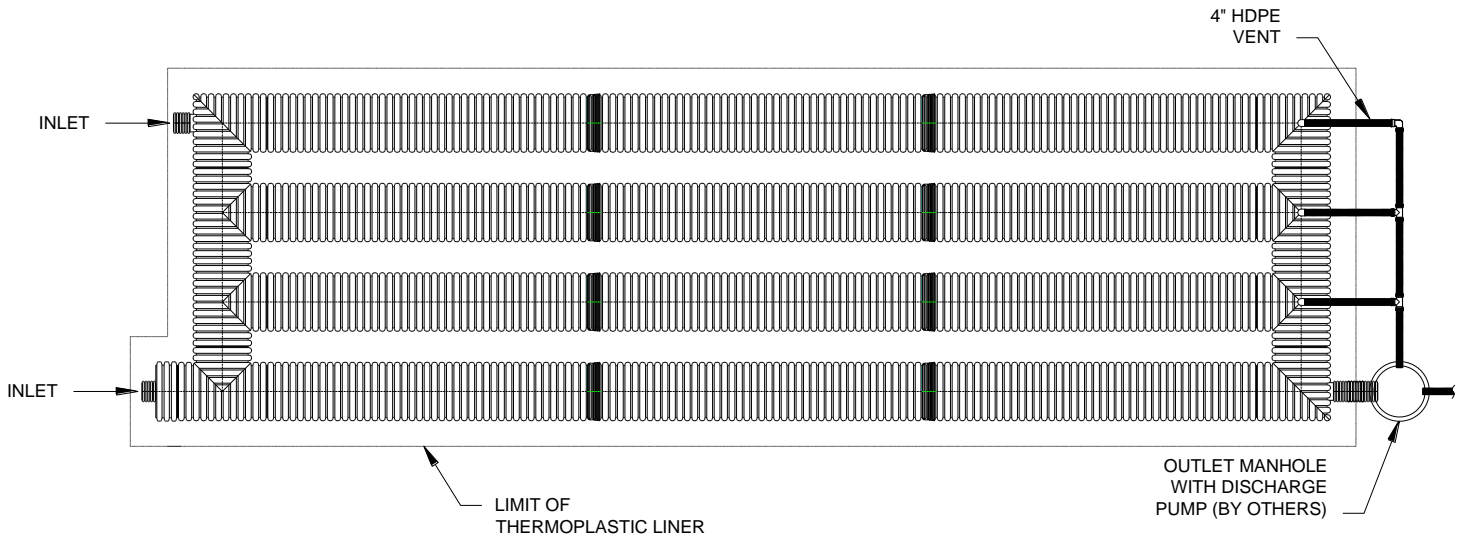
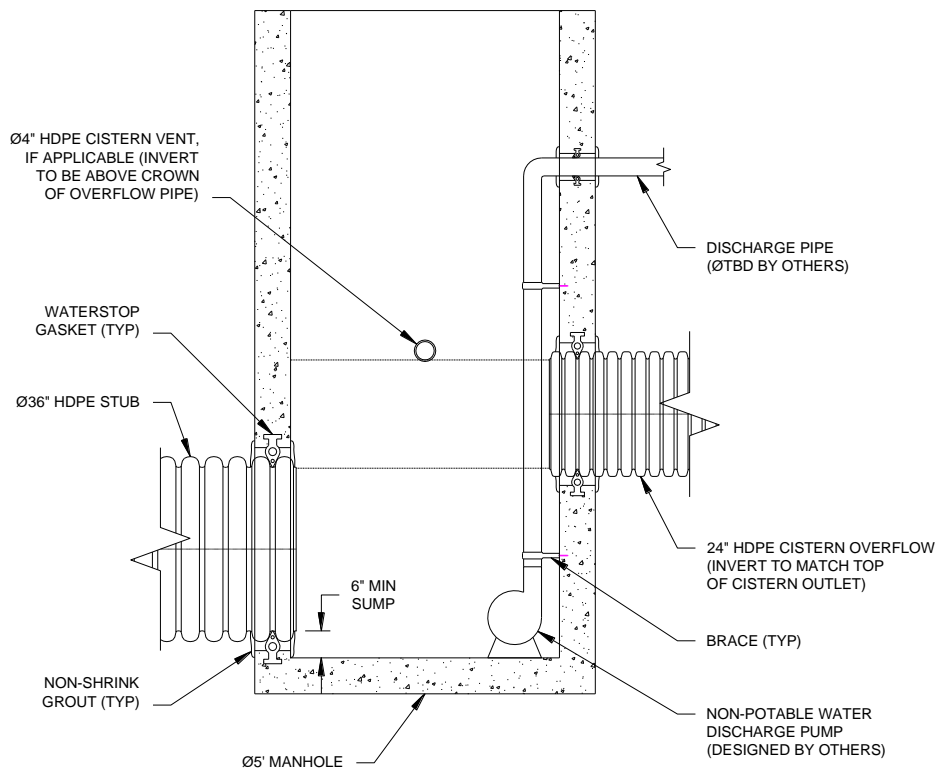

Figure 2
Outlet Manhole Typical Detail



Storage Capacity

ADS cisterns maximize storage capacity by using pipe and stone voids together for total system storage. Table 1 lists storage volume per pipe diameter, stone void volume per pipe diameter and total storage volume for pipe and stone together.

Table 1
Pipe Storage Capacity

Nominal Inside Diameter	Average Outside Diameter	“X” Spacing	“S” Spacing ¹	“C” Spacing ¹	Pipe Volume ²	Stone Void Volume ^{3,4,5}	Total Storage
in. (mm)	in. (mm)	in. (mm)	in. (mm)	in. (mm)	ft ³ /ft (m ³ /m)	ft ³ /ft (m ³ /m)	ft ³ /ft (m ³ /m)
12 (300)	14.5 (368)	8 (200)	11 (279)	25.4 (645)	0.79 (0.07)	1.1 (0.10)	1.8 (0.16)
15 (375)	18 (457)	8 (200)	12 (305)	28.9 (734)	1.2 (0.11)	1.4 (0.13)	2.6 (0.24)
18 (450)	21 (533)	9 (230)	17 (434)	33.9 (862)	1.8 (0.16)	1.7 (0.15)	3.5 (0.32)
24 (600)	28 (711)	10 (250)	13 (330)	40.7 (1034)	3.1 (0.29)	2.6 (0.24)	5.7 (0.52)
30 (750)	36 (914)	18 (450)	18 (457)	53.1 (1347)	4.9 (0.46)	3.7 (0.34)	8.6 (0.79)
36 (900)	42 (1067)	18 (450)	22 (559)	63 (1600)	7.1 (0.66)	4.7 (0.43)	11.8 (1.08)
42 (1050)	48 (1219)	18 (450)	24 (610)	71.9 (1826)	9.3 (0.87)	5.8 (0.53)	15.1 (1.38)
48 (1200)	54 (1372)	18 (450)	25 (1219)	78.5 (1994)	12.4 (1.15)	7.0 (0.64)	19.4 (1.78)
60 (1500)	67 (1702)	18 (450)	24 (1524)	90 (2286)	19.3 (1.79)	9.7 (0.89)	29.0 (2.66)

Notes:

See Figure 3 for typical cross section used in volume calculations

Bedding depth assumed 4” for 12”-24” pipe and 6” for 30”-60” pipe.

1. Based on A-profile pipe.

2. Actual ID values used in calculation.

3. Stone Porosity assumed 40%.

4. Stone height above crown of pipe is not included in void volume calculations.

5. Calculation is based on the average OD of the pipe.

Installation

For a cistern application, ADS N-12 perforated pipe embedded in a Class I crushed stone backfill is recommended. See Figure 3 for minimum recommended cover heights for standard installations. A maximum of 1 ½” aggregate size is preferred and the stone should be clean with no fines. The stone backfill provides two critical elements to the cistern design. First, the stone provides necessary structural support for the system to withstand dead loads and vehicular loading. Secondly, the stone provides a certain void volume which can be incorporated into the total storage volume that the cistern can provide. This can help with the reduction of the cistern size and keep the overall footprint to a minimum.

Up to this point, the design is no different than the traditional ADS HDPE pipe infiltration system. The traditional infiltration system would include the use of a geotextile to separate the stone backfill from the native material. For a cistern, a thermoplastic liner shall be used in place of the geotextile as shown in Figure 1. The liner will maintain the water tight integrity of the cistern and hold the stormwater in place before it is reclaimed. Because of the use of a thermoplastic liner, installation of cisterns below groundwater is not recommended due to potential issues with buoyancy and hydrostatic head. To prevent issues with groundwater, an underdrain can be placed under the liner so long as gravity discharge is available. Additional consultation with a geotechnical engineer may be necessary to address groundwater concerns.

Figure 3
Typical Cistern Cross Section

Note: This is a typical cross section only. See Structures, Section 2, or Installation, Section 5, of the Drainage Handbook for specific installation guidelines.

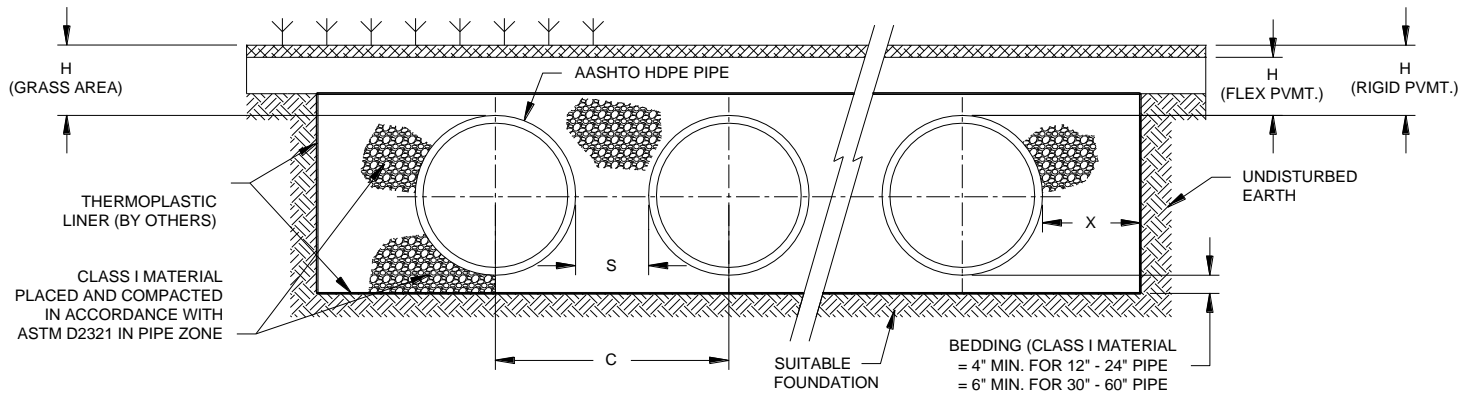

Thermoplastic Liner

ADS does not design, fabricate, install or sell thermoplastic liners. The following product details are based on information supplied and published by thermoplastic liner manufacturers. Generally speaking, there are two liner materials that are suitable for this application: polyvinyl chloride (PVC) and linear low density polyethylene (LLDPE). PVC liners are easy to install making it a low cost alternative. Some PVC liners contain fillers and plasticizers. Under prolonged exposure to sunlight, these compounds can leach from the liner. With use in a cistern application, exposure from sunlight is not a concern since the system is located underground. The LLDPE is an inert material that is suitable for the storage of stormwater and would be acceptable for this application. Medium and high density liners are also available but are not as flexible as the low density product and are typically higher in cost.

For any liner, puncture resistance needs to be considered. This can be addressed by the placement of non-woven geotextile on either side of the membrane. The liner seam, if applicable, should be watertight to maintain the integrity of the system. Pipe "boots" need to be pre or field fabricated for locations where system piping is either entering or exiting the cistern footprint, i.e. inlet and outlet piping. A detail depicting the liner "boot" is shown as Figure 4. The other factor that needs to be considered when using a thermoplastic liner is the seasonal high water table. High water tables can create excessive hydrostatic pressure and potentially damage the liner.

Figure 4
Liner Pipe Connection Detail

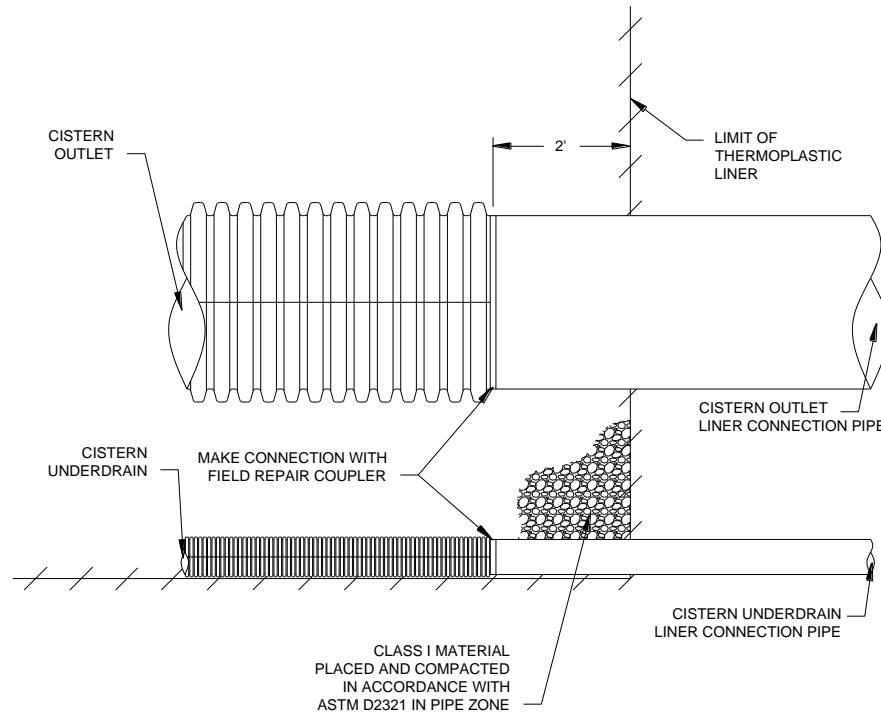

NOTES:

1. CONNECTIONS OF PIPE TO THERMOPLASTIC LINER SHALL BE MADE AT THE DIRECTION OF LINER MANUFACTURER.
2. CISTERN LINER CONNECTION PIPE SHALL BE CONNECTED DIRECTLY TO OUTLET STRUCTURE.
3. CISTERN PIPE SHALL BE CONNECTED TO LINER CONNECTION PIPE WITH FIELD REPAIR COUPLER.

Installation of liners should be in accordance with the manufacturer’s recommendations. ADS recommends consulting with the liner manufacturers for final design, installation and cost information regarding the liner component of the cistern design.

Cistern Design

Due to the similarity of the cistern to an infiltration system, the ADS Retention/Detention Calculator can be used to size the pipe, fittings and stone component of the cistern. The Calculator can be accessed via the ADS website at www.ads-pipe.com.

The required bed size is indicated in the excavation section of the Calculator. The required amount of thermoplastic liner can be calculated from these bed dimensions as follows:

$$((H * L * 2) + (H * W * 2) + (L * W * 2)) = \text{required amount of liner in square feet}$$

where:

- H = height of cistern section
- L = length of cistern section
- W = width of cistern section

This calculation is based on a design in which the cistern is completely encased within the thermoplastic liner which is at the engineer's discretion. In the event that the system is not completely encased and the liner extends below and along the sides of the cistern, the calculation is as follows:

$$((H * L * 2) + (H * W * 2) + (L * W)) = \text{required amount of liner in square feet}$$

where:

H = height of cistern section

L = length of cistern section

W = width of cistern section

Technical Assistance

Throughout cistern design, ADS can assist with a variety of technical issues on the use of our HDPE pipe and fittings, including:

- Product performance information and suggested product usage
- Manifold pipe configuration and design
- Number and spacing of system laterals (based on provided design storage)
- Existing product modifications; custom product fabrication
- Suggestions to maximize cost effectiveness

Please contact an ADS representative for further information.

Note: The use of cisterns is not recommended as a fire suppression source due to impact of weather variations on water supply and ultimately availability.



Sanitary Sewer Systems



7-0 SANITARY SEWER SYSTEMS

TABLE OF CONTENTS

- 7-1 Overview of Sanitary Sewer Systems..... 7-2**
- 7-2 Sanitary Sewer Projects 7-2**
 - Preliminary Investigation 7-2
 - Design Considerations 7-2
 - Construction..... 7-3
 - Operation 7-3
- 7-3 ADS SaniTite® HP Pipe..... 7-3**
 - Pipe Design 7-4
 - Bell & Spigot Joint..... 7-4
 - Fittings 7-4
 - Structural Design 7-5
 - Hydraulic Characteristics..... 7-5
 - Durability Characteristics..... 7-5
- 7-4 Installation Considerations 7-5**
 - Manhole and Structure Connections..... 7-6
 - Drop Manholes 7-6
 - Service Connections and Laterals 7-7
 - Horizontal Curves 7-8
 - Casings..... 7-8
 - Thrust Restraint 7-8
 - Groundwater..... 7-9
 - Post-Installation Testing 7-9
- 7-5 References 7-10**
- 7-6 Additional Technical Resources..... 7-10**

Figures

- 7-1 Outside Drop Manhole Installation 7-7
- 7-2 Stub Orientation for Connections 7-7
- 7-3 Thrust Block Placement 7-9

7-1 OVERVIEW OF SANITARY SEWER SYSTEMS

Construction of new sanitary sewer systems, as well as the separation of older combined sewers due to environmental concerns, is a necessity for community development and growth. Being essential to public health and overall welfare, sanitary sewers serve to collect and transport domestic, commercial and industrial wastewaters to a facility for treatment and disposal. For existing combined storm and sanitary sewers, a community's investment in a dedicated sanitary sewer will aid environmental protection as well as exclude storm water from the costly treatment processes.

There are a number of design considerations, including corrosion resistance, structural strength, hydraulic characteristics, and overall service life, that influence the selection of a pipe material. Finding a balance between annual service costs and the system's functionality and durability over the service life is a critical decision when making such a large monetary community investment.

7-2 SANITARY SEWER PROJECTS

A sanitary sewer project can be categorized into four main stages of development: preliminary investigation, design, construction and operation. The following briefly describes each stage of development and its impact on the project.

PRELIMINARY INVESTIGATION

One the most critical stages of sewer development is the planning stage. Inadequate preliminary and investigative work may adversely affect the design or construction, compromising the successful completion of the system in a timely and economical manner. Both the engineer and owner must work together during this developmental stage, though all policy and financial decisions remain exclusively with the owner.

An engineering report is typically submitted once all preliminary work is done. Included in the engineering report will be a review of existing conditions as well as proposed methods and generic layouts that will meet the project's goals. While information tends to be relatively broad during this stage, some specificity is necessary in order to establish construction and operation cost estimates. Without preliminary sizing, design data, financial planning, feasibility and the overall consideration of all alternatives this stage cannot be adequately completed.

DESIGN CONSIDERATIONS

The design phase includes the preparation of the construction documents by the design engineer. Plans and specifications will provide contractors, distributors and vendors with information necessary for bid proposal and determining suitable products. The owner will continue to provide input and information as needed to

ensure the project meets the community's needs, as well as review any alternatives that are presented by the engineer.

Sanitary sewer system design has two primary considerations: the design period for which the sanitary sewer will meet capacity requirements and the design flow expected over the design period.

The design period for most sanitary trunk lines and interceptors is 50-years. More rural or undeveloped areas may limit the development period. The design period is also based on past and future water use, population trends and current usage statistics.

The design flow is simply the quantity of water that will be conveyed through the system. The determination of the design flow rate is primarily dependent on the population served, population density, and water consumption. In some communities however, inflow from non-wastewater sources, like roof and foundation drains, may also be included in the peak design flow. It follows intuition that construction costs associated with sanitary sewers conveying both wastewater and non-wastewater will be higher than costs of sanitary sewers in communities that prohibit non-wastewater connections. Ascertaining the peak design flow for a specific community will be influenced by past usage, topography and political considerations, all of which will vary regionally.

CONSTRUCTION

Once all plans have been finalized and approved by the owner, the contractor assumes the liability of building the project per the drawings and specifications. During this stage, the engineer often becomes a representative of the owner, ensuring all work is done in accordance with the contract documents. The engineer will review any submittals from the contractor for proposed products or installation procedures as well as troubleshoot any issues that may arise from errors in the construction documents or if site conditions vary from the construction documents, thereby affecting the anticipated progress of work.

OPERATION

Upon completion of construction, the owner will accept the system and take final responsibility for operation and maintenance. The engineer will provide all necessary operation and maintenance information to the owner for the proper function of all parts of the system. In some cases, the engineer or an outside consulting or maintenance company may be contracted to assist with the operation of the system.

7-3 ADS SANITITE[®] HP PIPE

The overall efficiency of a sanitary sewer system depends on a balance of the initial construction costs and the long-term performance of the system. Lower initial construction costs with poor materials may result in high long-term maintenance costs, or even replacement before the design period expires if serious issues arise.

However, high initial construction costs may put excessive burdens on the community which can adversely affect future development.

To aid the designer in selecting a pipe material that will be suitable for the specific project, the following provides design information specific to ADS SaniTite HP pipe:

PIPE DESIGN

The SaniTite HP product is made from polypropylene resin which is analogous to combining the durability of high density polyethylene (HDPE), and the stiffness of poly-vinyl chloride (PVC) but with improved impact resistance and less susceptibility to brittleness. SaniTite HP pipe is available in 12- through 60-inch (300 to 1500mm) diameters. Polypropylene products can be distinguished from other ADS pipe products by its light grey color.

ADS SaniTite HP pipe uses the state-of-the-art design that incorporates profile wall geometry for structural strength and a smooth inner wall for hydraulic capacity. The 12- through 24- inch (300 – 600mm) pipe has a corrugated exterior while the 36- through 60-inch (900-1500mm) diameter pipe incorporate an exterior shell over the corrugations. The 30-inch (750mm) pipe can have a corrugated exterior or an exterior shell over the corrugations. The smooth inner wall combines superior hydraulics with the ability to resist abrasion and corrosion. The corrugated wall provides the strength necessary to withstand live loads associated with heavy traffic and dead loads associated with deep burials. The outer shell on large diameter pipe provides added stiffness and beam strength.

BELL & SPIGOT JOINT

The SaniTite HP joint features an extended bell-and-spigot joint that promotes faster, easier installation along with increased joint performance from the presence of two gaskets and a reinforced bell with a polymer composite band. This joining method ensures joint alignment, improves joint reliability, and eliminates the need for glue or secondary joining operations. Joints provide a watertight level of performance meeting the laboratory requirements set in ASTM D3212 with the exception of an increased pressure of 15psi (100 kPa) with zero leakage. In field applications, SaniTite HP pipe may be tested with an allowable leakage rate in accordance with ASTM F2487 or F1417. SaniTite HP pipe is intended for non-pressure, gravity flow sanitary sewers.

FITTINGS

A large selection of fittings are available for SaniTite HP pipe, including tees and reducing tees, wyes and reducing wyes, and as well as reducers. Custom fabricated fittings may also be available and will be evaluated based on the application conditions. Fabricated fittings with an excess of 8-ft (2.4m) of cover should be reviewed by the Engineering Services Department.

STRUCTURAL DESIGN

For evaluating SaniTite HP pipe's structural performance, the American Association of State Highway Transportation Officials (AASHTO) Load Resistance and Factor Design (LRFD) method for thermoplastic pipe is used. An explanation of the design method, including pipe dimensional properties required for design, is available in Section 2: *Structures* of this handbook. A maximum cover height table, based on the backfill material and compaction level, for SaniTite HP is also available in Technical Note 2.05: *Minimum and Maximum Cover Heights for SaniTite HP*, included in this manual.

HYDRAULIC CHARACTERISTICS

Based on site requirements, the design engineer will determine if the sewer will be gravity-flow or a force main. ADS sanitary sewer products are only intended for gravity-flow conditions. The design Manning's "n" value for SaniTite HP is 0.012. Flow capacity charts may be found in Section 3: *Hydraulics* section of this handbook.

DURABILITY CHARACTERISTICS

Another critical consideration during pipe material selection is its durability in the corrosive environment typically found in sanitary systems. Some designs are able to limit the concentration of corrosive chemicals in the system through regular maintenance or point-source control but their presence altogether is typically unavoidable. SaniTite HP pipe is made from chemically inert and highly durable polypropylene material which is unaffected by most common sanitary sewer chemicals including hydrogen sulfide. Additional information on the durability of the product is available in Section 4: *Durability* of this handbook. Chemical resistance tables for both polypropylene and available gasket materials for the joint are available in Technical Note 4.02: *Chemical Resistance of Polypropylene and Elastomers*, included in this handbook.

7-4 INSTALLATION CONSIDERATIONS

Standard installation recommendations for all ADS pipe products are provided in Section 5: *Installation* of the Drainage Handbook. Installation recommendations specific to ADS SaniTite HP pipe based on the minimum or maximum fill height over the pipe are provided in Technical Note 2.05: *Minimum and Maximum Cover Heights for SaniTite HP Pipe*.

The selection of a suitable pipe product will also be dependent on any special installation requirements for the system. The need for additional fittings, structures or installation measures may increase anticipated costs. The following addresses some common considerations along with recommendations for the proper use of SaniTite HP pipe.

MANHOLE AND STRUCTURE CONNECTIONS

Quite often, manhole connections will need to be watertight. Since concrete does not readily adhere to thermoplastic material, a compression gasket or boot connection will need to be used.

The use of flexible manhole connections will allow for some flexure at the connection if some differential settlement occurs, but care should still be taken to properly backfill and compact underneath the pipe at the manhole to avoid shearing forces that may damage the pipe. Using a short section of pipe, 3- to 6-ft (0.9-1.8m) long will also help minimize affects of manhole settlement.

The outside diameter and profile of the pipe connecting to the structure are critical for selecting the correct manhole gasket or boot. Standard details are available that provide the pipe or fitting's outside diameter, as well as the part number of the respective manhole compression gasket or boot connection that are supplied by other manufacturers. Please contact your local sales representative for this information.

DROP MANHOLES

For areas in the system where there is a significant change in grade or elevation due to topography, a drop manhole may be used. Due to space constrictions within the manhole and to avoid the increased costs of larger manholes, outside drop structures are typically used. To prevent pipe settlement when placed vertically, the entire section should be encased in concrete to ensure adequate support of the pipe. Figure 7-1 shows a typical outside drop manhole installation. Based on diameter, a standard tee or wye fitting may be used to transition to the lower section of the drop connection.

Figure 7-1
Typical Outside Drop Manhole

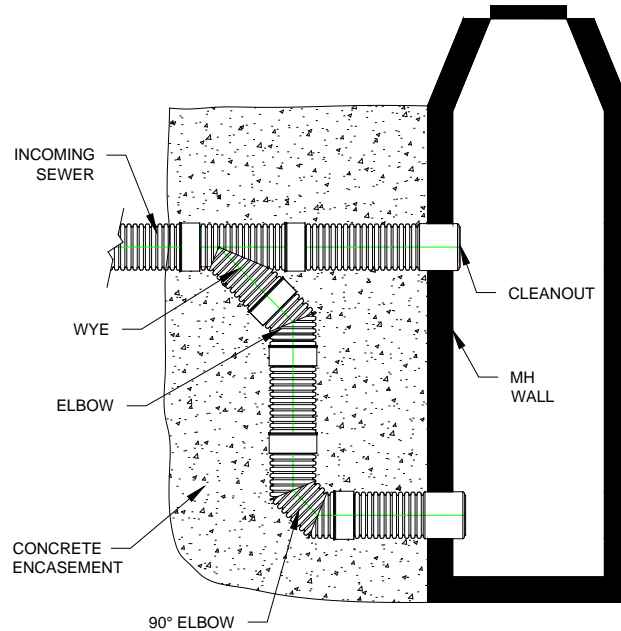

SERVICE CONNECTIONS & LATERALS

Sanitary sewer systems may require changing pipe materials, sizes, elevation, or direction. Local regulations may require using a manhole or structure to make these transitions but other options such as fittings or adapters specifically designed for this application may also be acceptable. Verify local requirements prior to ordering fittings, adaptors, and other accessories and components.

If using an Inserta-Tee[®], Fernco[®] QwikSeal[™], or other field tap connection, the stub portion should not be placed at an angle greater than 45-degrees from horizontal. Stubs that must be oriented at an angle greater than 45-degrees from horizontal may require flowable fill or concrete backfill to prevent settlement into the mainline pipe.

Figure 7-2
Stub Orientation for Field Connections

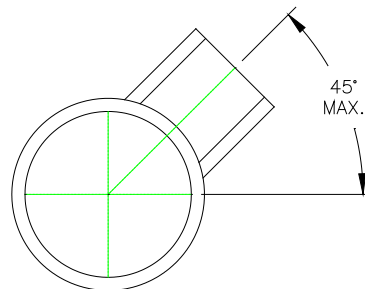

HORIZONTAL CURVES

To improve hydraulics or as a cost saving measure to reduce manholes, pipe lines may have gradual curves. A radius of curvature can be achieved by laying straight sections of pipe and only deflecting the joint. In order to maintain joint performance, joint articulation should not exceed 3-degrees. Depending on project requirements, fittings may also be used to create gradual transitions along the pipeline. It is imperative the pipe itself shall never be bent or deflected in order to create a radius.

CASINGS

Installations that must avoid disturbing the ground surface, whether under a heavily travelled or protected area, or where high impact surface loads are expected, will require the use of a casing pipe. ADS products are not to be used during the jacking or boring operations and should only be installed in a casing pipe that can withstand the installation operations and final loading conditions. Other circumstances requiring the use of a casing pipe include river crossings, pipe crossings in close proximity, or high groundwater pressures.

In contrast to sliplining installations where existing pipe is deteriorated or failing, the casing pipe is installed shortly before the placement of the sewer pipe. A horizontal bore is created using a rotating auger within a steel casing. The casing used during boring may be left as the final casing pipe or a different casing pipe is installed once boring operations are complete.

The outside diameter of the sewer pipe and the inside diameter of the casing pipe should be compared to ensure there is adequate space for work procedures. Manufactured casing spacers or skids should be secured to the sewer pipe in order to safely insert the pipe into the casing pipe. Constant longitudinal support of the pipe is needed to maintain a constant grade. Where full longitudinal support cannot be achieved using spacers or skids, grout may be used to provide support of the pipe and prevent flotation. For more detailed recommendations related to installing pipe through casings, refer to Technical Note 5.18 Lining of Casings with SaniTite HP Pipe

THRUST RESTRAINT

For gravity-flow systems additional measures may still be required to prevent joint separation. Most commonly, a change in flow direction or the presence of a soil with inadequate bearing strength to withstand the load will necessitate some form of thrust restraint. Line connections with a tee, directional changes with a bend and where the pipeline size changes are common transitions where additional restraint may be required.

Cast in place concrete thrust blocks are the most common preventative measure taken. A generic example is shown in Figure 7-3. A thrust block should not encase the entire joint;

otherwise flexibility of the joint will be limited. Concrete shall also be poured against undisturbed earth to minimize soil consolidation.

Figure 7-3
Cast In Place Thrust Block Placement

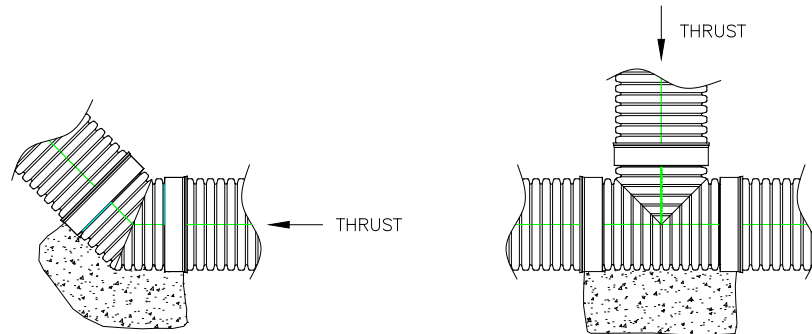

Precast concrete blocks may also be used, but should not be placed directly against the pipe to avoid point loads on the fitting. Backfill should be placed between the face of the precast block and the fitting in order to provide uniform support of the fitting.

The design of a thrust block is a function of the thrust force and the load-bearing capacity of the soil. For gravity-flow systems, the thrust force will vary based on the effluent velocity and pipe diameter. When soil conditions are unknown, soil samples should be collected and tested in order to determine the soil type. Engineering reference manuals will provide typical soil bearing capacities based on soil type. Burial depth can also be considered when determining soil bearing capacity, where shallow (less than 3-ft [0.9m]) installations will lower the soil's bearing capacity.

GROUNDWATER

The maximum cover heights listed in Technical Note 2.05: *Minimum and Maximum Cover Heights for SaniTite HP Pipe* do not account for hydrostatic pressure due to groundwater. ADS Applications Engineering can assist in determining the pipe's structural performance in accordance for LRFD Section 12 for projects where the published assumptions are exceeded.

POST-INSTALLATION TESTING

Post-installation testing is commonplace for most sanitary sewer installations. Thermoplastic pipes are tested for either joint integrity or deflection, or both.

Joint integrity is tested by either pressurizing a run of pipe to determine the leakage rate or by isolating a specific number of joints and pressurizing only the joint to determine the leakage rate. The project's acceptable leakage rate will be a function of the test pressure and test duration. Performance testing will use either air or water to pressurize the void space in the pipe run or joint area. Refer to the *Installation* section of the Drainage Handbook for additional information on infiltration/exfiltration and air testing.

For SaniTite HP, ASTM F2487 is recommended for infiltration/exfiltration testing, with a leakage rate of 50 gal/inch-diameter/mile-pipe/day. ASTM F1417 is recommended for air testing. Caution should be exercised to ensure any testing is done safely. While an allowable leakage rate of 200 gal/in-diam/mile-pipe/day is a common industry standard, regional leakage rates should be consulted for the specific project.

Deflection testing of thermoplastic pipe provides a relatively quick indicator of how well the backfill was placed around the pipe within days of the installation. A deflection of 7.5% after 30 days is a commonly accepted limit. Although the allowable deflection limit is ultimately up to the design engineer, it should always be based on a prescribed period of time, typically 30 days. Determining the allowable inside diameter of the tested pipe is often stated in the projects written specification but may also be based on the pipe's initial base inside diameter. For more information on deflection testing methods and base diameter values of ADS pipe for deflection limits, refer to Technical Note 5.17: *Post-Installation Testing for SaniTite HP*, included in this manual.

7-5 REFERENCES

Gravity Sanitary Sewer Design and Construction (ASCE Manuals and Reports on Engineering Practice No. 60) (WPCF Manual of Practice No. FD-5). (1982). Virginia: American Society of Civil Engineers and Water Pollution Control Federation.

7-6 OTHER TECHNICAL RESOURCES

ADS Technical Notes

Technical Note 2.05: *Minimum and Maximum Cover Heights for SaniTite HP Pipe*

Technical Note 4.02: *Chemical Resistance of Polypropylene and Elastomers*

Technical Note 4.03: *Abrasion Resistance of Polypropylene*

Technical Note 5.01: *Recommended Use for Trench Boxes*

Technical Note 5.02: *Flowable Fill Backfill for Thermoplastic Pipe*

Technical Note 5.05: *Pipe Flotation*

Technical Note 5.13: *SaniTite HP Pipe Repair Options*

Technical Note 5.14: *Culvert Sliplining with HP Pipe*

Technical Note 5.15: *Integral Bell Transition for HP Pipe*

Technical Note 5.16: *Sealing Methods for Vent Tubes*

Technical Note 5.17: *Post-Installation Testing of HP Pipe*

Technical Note 5.18: *Lining of Casings with SaniTite HP Pipe*

ADS Standard Details

Standard Detail 101F: Trench Installation Detail (SaniTite HP)

Standard Detail 205A through 205G: *SaniTite HP Manhole Connections*

Standard Detail 408 through 410: *SaniTite HP Tee Base Details*

Sanitary Tech Notes



9-0 SANITARY TECHNICAL NOTES

TABLE OF CONTENTS

Section 1 – General Specifications

1.07 Manhole Adapter Guide – SaniTite HP and HP Storm Pipe

Section 2 – Structures

2.05 Minimum and Maximum Cover Heights for SaniTite HP Pipe for Sanitary Sewer

Section 5 – Installation

5.13 SaniTite HP Sanitary Sewer Pipe Repair Options

5.17 Post Installation Testing of SaniTite HP

5.18 Lining of Casings with SaniTite HP Pipe

Technical Note

TN 1.07 Manhole Adapter Guide - SaniTite® HP and HP Storm Pipe

Manhole Connection Basics

Compression Connections

- Gasket is cast into the wall of the manhole at the precaster's facility. Gasket cannot be field installed.
- A-LOK® Premium™ is recommended for all connections. The Premium gasket has higher compression than the A-LOK STM standard gasket, which aids in sealing against the outer wall of SaniTite HP triple wall pipe and the SaniTite HP manhole adapter sleeve for dual wall pipe.
- A-LOK gaskets always need to connect to a smooth surface of pipe – Nyloplast® adapter or ADS adapter sleeves are required when using dual wall pipe. Triple wall pipe requires no adapter.



Boot Connections:

- Gasket can be installed by the precaster or field-installed by the contractor. The precaster will form the required hole in the structure and either the precaster or contractor will install the boot.
- Preferred manufacturers are Press Seal® (PSX Direct Drive) and Trelleborg (Kor-n-Seal®).
- Boots always need to connect to a smooth surface. You can connect to a dual wall pipe with an installed corrugated pipe adapter (valley fill gasket) or a Manhole adapter sleeve.

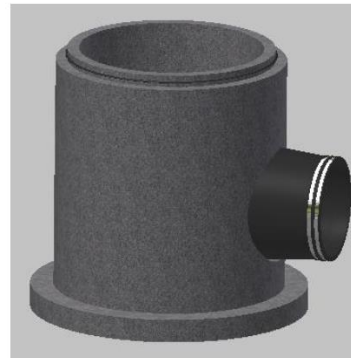

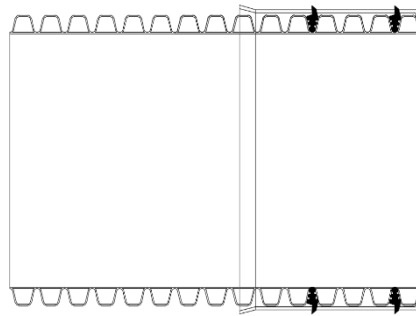
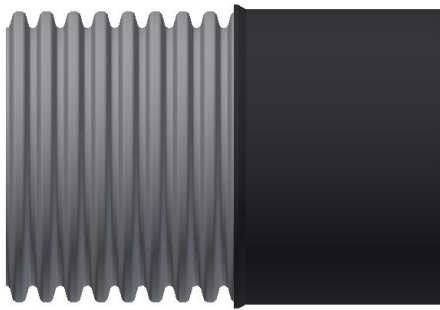

Sleeve Manhole Adapter

Boot or Compression Connection

For HP & HDPE
12" - 24" (XX22AAPP)
Sanitary or Storm Joint

Not Available for 21"

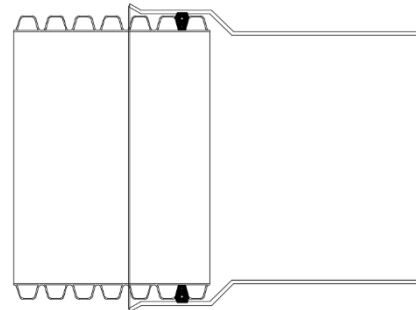
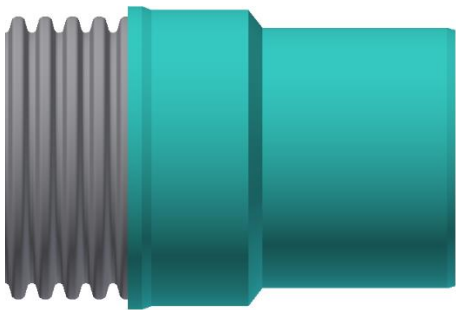

Nyloplast® PVC Manhole Adapter

Same OD as SDR35

Boot or Compression Connection

HP { 12" - 24" (XX57AGHPU2) Sanitary Joint
12" - 30" (XX57AGHPU) Storm Joint

HDPE { 12" - 30" (XX77AGU) Storm Joint

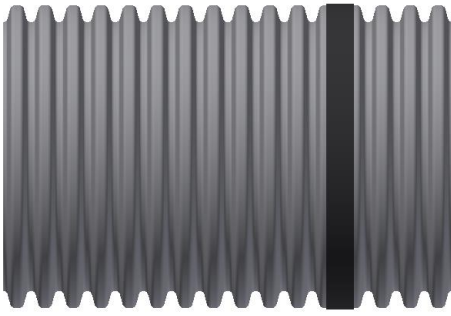

Corrugated Pipe Adapter Gasket

Boot Connection Only
(XX50PS)

12" – 30" Sanitary or Storm Joint

36" – 60" Storm Joint

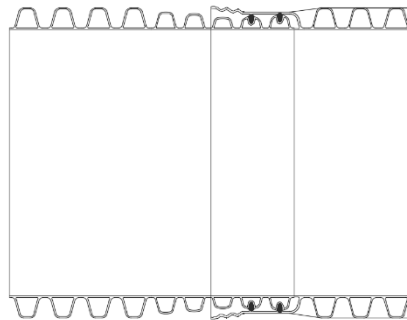
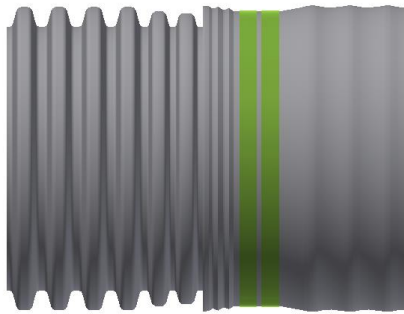

SaniTite HP TW to HP Storm DW

Boot or Compression Connection

30" – 60" Dual Wall

Storm Joint

Coordinate with plant to ensure correct gasket
for compatibility is installed prior to shipment.

CONSULT ADS SERIES 200 STANDARD DETAILS



The ADS logo, SaniTite HP, N-12 and the Green Stripe are registered trademarks of Advanced Drainage Systems, Inc.
Nyloplast® is a registered trademark of Nyloplast, Inc.
© 2022 Advanced Drainage Systems, Inc. TN 1.07 April 2022

adspipe.com

1-800-821-6710

Technical Note

TN 2.05 Minimum and Maximum Cover Heights for SaniTite® HP Pipe for Sanitary Sewer

Introduction

The information in this document is designed to provide answers to general cover height questions; the data provided is not intended to be used for project design. The design procedure described in the *Structures* section (Section 2) of the Drainage Handbook provides detailed information for analyzing most common installation conditions. This procedure should be utilized for project specific designs.

The two common cover height concerns are minimum cover in areas exposed to vehicular traffic and maximum cover heights. Either may be considered "worst case" scenario from a loading perspective, depending on the project conditions.

Minimum Cover in Traffic Applications

Pipe diameters from 12- through 48-inch (300-1200 mm) installed in traffic areas (AASHTO H-20, H-25, or HL-93 loads) must have at least one foot (0.3m) of cover over the pipe crown, while 60-inch (1500 mm) pipes must have at least 24 inches (0.6m) of cover. The backfill envelope must be constructed in accordance with the *Installation* section (Section 5) of the Drainage Handbook and the requirements of ASTM D2321. The backfill envelope must be of the type and compaction listed in the *Installation* section of the Drainage Handbook, Appendix A-5, Table A-5-2. In Table 1 below, this condition is represented by a Class II material compacted to 90% standard Proctor density although other material can provide similar strength at slightly lower levels of compaction. Structural backfill material should extend to the crown of the pipe; the remaining cover should be appropriate for the installation and as specified by the design engineer. If settlement or rutting is a concern, it may be appropriate to extend the structural backfill to grade. Where pavement is involved, sub-base material can be considered in the minimum burial depth. While rigid pavements can be included in the minimum cover, the thickness of flexible pavements should not be included in the minimum cover.

Additional information that may affect the cover requirements is included in the *Installation* section (Section 5) of the Drainage Handbook. Some examples of what may need to be considered are temporary heavy equipment, construction loading, paving equipment and similar loads that are less than the design load, the potential of pipe flotation, and the type of surface treatment which will be installed over the pipe zone. Please note Table 1 and 2 are based on the installation of SaniTite HP under pavement using a uniform backfill type and compaction level, as depicted in Figure 1.

Table 1
Minimum Cover Requirements for ADS SaniTite HP with AASHTO H-20, H-25, or HL-93 Load

Inside Diameter, ID, in.(mm)	Minimum Cover ft. (m)	Inside Diameter, ID, in.(mm)	Minimum Cover ft. (m)
12 (300)	1 (0.3)	36 (900)	1 (0.3)
15 (375)	1 (0.3)	42 (1050)	1 (0.3)
18 (450)	1 (0.3)	48 (1200)	1 (0.3)
24 (600)	1 (0.3)	60 (1500)	2 (0.6)
30 (750)	1 (0.3)		

Notes:

1. Minimum covers presented here were calculated assuming Class II backfill material compacted to 90% standard Proctor density around the pipe and backfill to the crown of the pipe, as recommended in Section 5 of the Drainage Handbook, with an additional layer of compacted traffic lane sub-base for a total cover as required. In shallow traffic installations, especially where pavement is involved, a good quality compacted material to grade is required to prevent surface settlement and rutting.
2. The minimum covers specified do not include pavement thickness. A pavement section of 0.4' is typical.
3. Backfill materials and compaction levels not shown in the table may also be acceptable. Contact ADS for further detail.
4. Calculations assume no hydrostatic pressure and native soils that are as strong as the specified minimum backfill recommendations.

Maximum Cover

Wall thrust generally governs the maximum cover a pipe can withstand and conservative maximum cover heights will result when using the information presented in the *Structures* section (Section 2) of the Drainage Handbook. Table 2 below shows the material properties consistent with the expected performance characteristics for SaniTite HP materials for a 100-year design life.

The maximum burial depth is highly influenced by the type of backfill and level of compaction around the pipe. General maximum cover limits for ADS SaniTite HP used in sanitary sewer applications are shown in Table 3 for a variety of backfill conditions.

Table 3 was developed assuming pipe is installed in accordance with ASTM D2321 and the *Installation* section (Section 5) of the Drainage Handbook. Additionally, the calculations assume no hydrostatic load around the pipe, incorporate the maximum safety factors represented in *Structures* section of the Drainage Handbook, use material properties consistent with the expected performance characteristics for SaniTite HP materials, and assume the native (in-situ) soil is of adequate strength and is suitable for installation. For applications requiring fill heights greater than those shown in Table 2 or where hydrostatic pressure due to groundwater is expected, contact an ADS Engineer.

**Table 2
ADS SaniTite HP Mechanical Properties**

Resin	ASTM Specification	Tension Strain %	Factored Compressive Strain %	Initial		100-Year*	
				Fu (psi)	E (psi)	Fu (psi)	E (psi)
Polypropylene, Impact-modified copolymer	ASTM F2764**	2.5	3.7	3,500	175,000	1,000	27,000

*Values extrapolated from AASHTO LRFD Section 12 minimum material requirements.

**ASTM F2736 has been incorporated into the latest version of ASTM F2764.

Figure 1
ADS SaniTite HP Pipe Trench Detail (Sanitary Sewer)

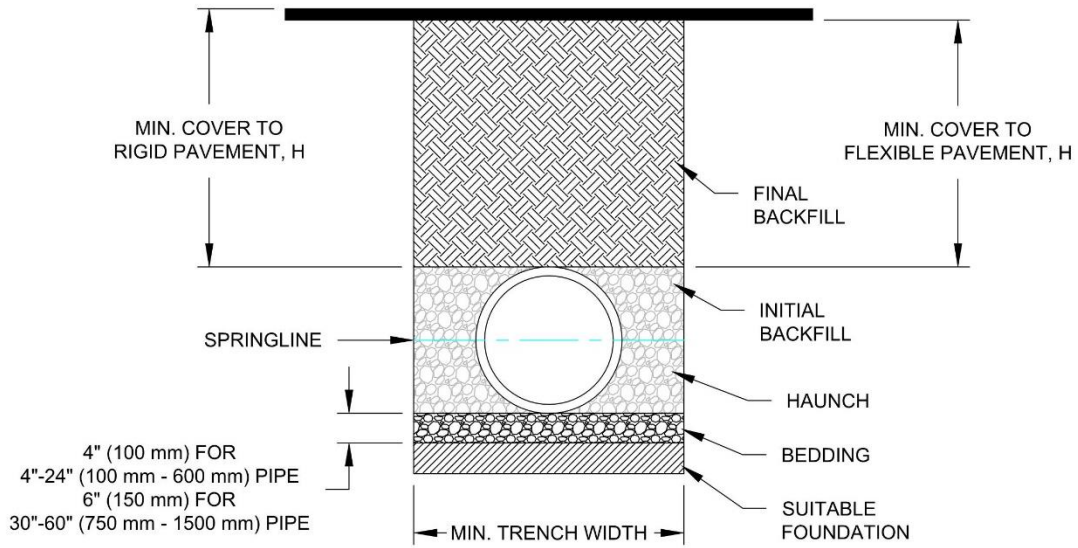

Table 3
Maximum Cover for ADS SaniTite HP Pipe for Sanitary Sewer, ft (m)

Diameter in (mm)	Class 1		Class 2	
	Compacted	95%	95%	90%
12 (300)	40 (12.2)	28 (8.5)	20 (6.1)	
15 (375)	41 (12.5)	29 (8.8)	20 (6.1)	
18 (450)	43 (13.1)	29 (8.8)	21 (6.4)	
24 (600)	37 (11.3)	25 (7.6)	18 (5.5)	
30 (750)	30 (9.1)	21 (6.4)	15 (4.6)	
36 (900)	29 (8.8)	21 (6.4)	15 (4.6)	
42 (1050)	32 (9.8)	22 (6.7)	16 (4.9)	
48 (1200)	33 (10.1)	23 (7.0)	16 (4.9)	
60 (1500)	31 (9.4)	21 (6.4)	15 (4.6)	

Notes:

1. Results based on calculations shown in the Structures section of the ADS Drainage Handbook (v20.7). Calculations assume no hydrostatic pressure and a density of 120 pcf (1926 kg/m³) for overburden material.
2. Installation assumed to be in accordance with ASTM D2321 and the Installation section of the Drainage Handbook.
3. Backfill materials and compaction levels not shown in the table may also be acceptable. Contact ADS for further detail.
4. Material must be adequately “knifed” into haunch and in between corrugations. Compaction and backfill material is assumed uniform throughout entire backfill zone.
5. Compaction levels shown are for standard Proctor density.
6. For projects where cover exceeds the maximum values listed above, contact ADS for specific design considerations.
7. See ADS Standard Detail STD-101F for additional details.



Technical Note

TN 5.13 SaniTite® HP Sanitary Sewer Pipe Repair Options

Introduction

ADS SaniTite HP for sanitary sewer is made of polypropylene (PP) resin making the pipe lightweight and very easy to handle. The attributes that make the pipe easy to use can also make it susceptible to abuse, possibly resulting in damaged pipe or joints. This technical note discusses some of the products available that can be used to repair damaged PP pipe or joints in the field.

Repair Options

One of the primary considerations in selecting a repair method is the degree of joint performance required. For sanitary sewer applications, a watertight repair is always necessary in contrast to storm drain repairs that may have a less stringent joint performance. A commonly accepted industry maximum allowance specified for infiltration/exfiltration acceptance for sanitary pipelines is 200 gal/in-diam./mile of sewer/day, though regional specifications may vary and be as stringent as 50 gal/in-diam./mile of sewer/day.

The way in which a pipe can be accessed is another primary consideration which influences what type of repair alternative is selected. Pipe that is not yet buried, or can be easily excavated, can be repaired from the exterior. If the pipe is buried and cannot be conveniently excavated, an internal repair may be the best alternative. If the pipe is too small to enter, there are companies with remote controlled equipment that can install the product. Each situation must be considered individually.

The repair options addressed below are divided into external repairs and internal repairs. During any pipe repair, backfill should be placed and compacted per project specifications to provide proper support for the pipe and coupler.

External Mechanical Repairs

Slip Couplings 12- through 30-inch (300 – 750 mm) , provides a watertight repair that will meet most pressure testing requirements, when installed correctly. The slip coupling uses PVC bells with gaskets. The gaskets are placed in the valleys on either side of the section to be repaired and slip couplings are then slid over the gaskets. Due to the exterior gasket, the slip coupling can only be used on pipe with a corrugated exterior. PVC slip couplings are most commonly used with watertight smooth interior thermoplastic pipe products. *Note: This repair method cannot be used with the triple wall, smooth exterior profile pipe.*

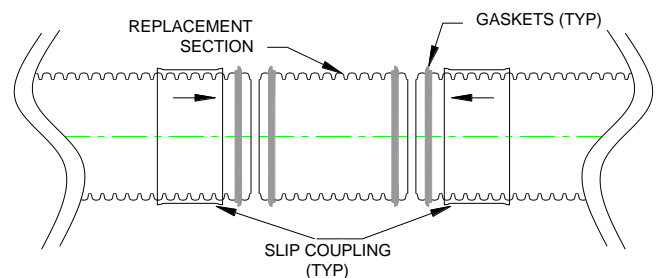

Large Diameter Repair Coupler 12- through 60-inch (300 – 1500 mm) are ideal for repairs and alterations of large diameter sewer pipe. Repair couplers similar to those provided by Mission Rubber Company LLC, Fernco® or equal may be used on SaniTite HP pipe.

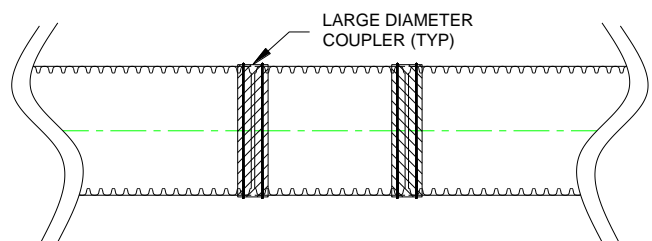

The couplers are used by removing the damaged section of pipe, replacing it with a new section and then sliding the coupler back around the joint, similar to the slip coupling above. The couplers stainless steel bands are then tightened to the manufactures recommendations. These rubber couplings are capable of meeting watertight field test requirements when installed per the manufacturer's recommendations.

Concrete Collar 12- through 60-inch (300 – 1500 mm), provides a water tight repair testable to most hydrostatic test with an appropriate leakage requirement. Installing a concrete collar involves building a form around the area to be repaired and encasing it in concrete. A *Mar Mac Polyseal Pipe Coupler* is wrapped around the repair area or joint prior to pouring the collar to keep the concrete from seeping into the pipe. *WaterStop* gaskets are installed outside of the *Polyseal* coupler towards the outside edge of the concrete collar. Typically, approximately 6" (0.15m) is excavated beneath the pipe to allow for proper application of the *Polyseal* coupler and concrete encasement. If the pipe itself is damaged, the damaged area shall be removed and a replacement pipe section spliced in prior to pouring the collar. This repair option may be employed for either dual wall or triple wall sanitary pipe.

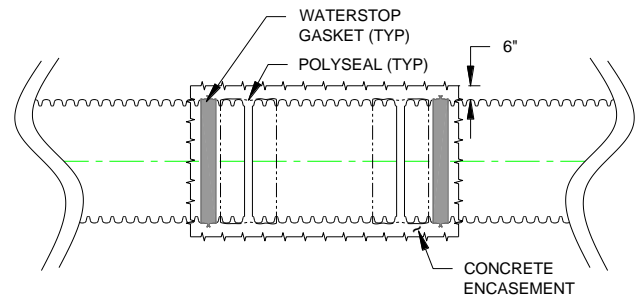

Internal Repairs

Internal mechanical repair products generally consist of a flexible cylindrical gasket sleeve, which is expanded to conform to the inner wall of the pipe. The feasibility of this repair method depends on the size of the damaged section or joint and available access into the pipe. Internal mechanical seals slightly restrict the inside diameter of the pipe. This should be considered when assessing the risk of debris obstruction.

NPC Internal Joint Seal, 18- through 60-inch (450 – 1500 mm), consists of an EPDM rubber seal and stainless steel bands. The rubber seal is inserted into the pipe and positioned over the joint. A torque wrench is used to expand the bands against the inner wall of the pipe. The Internal Joint Seal is designed to seal joints – not repair damaged pipe sections. The damaged area of the pipe must be removed and a replacement section spliced in if necessary in order to use the Internal Joint Seal. This system may provide a watertight joint when installed as recommended. The manufacture should be contacted to verify the product meets the specific application requirements including test requirements, if specified. If pressure tests are required, NPC should be contacted to ensure that the product is suitable for the specific test criteria.

Welding, 36- through 60-inch (900 – 1500 mm), is another method of internal joint repair where personnel use hand-held welding guns to make the needed repair. Extrusion welding techniques are most commonly utilized, however other welding methods may be used depending on the condition of the damage. Clean and dry working conditions and skilled operators are critical to a successful repair. Contact ADS to discuss the type of damage and to assess if a welded repair will be suitable.

Link Pipe Grouting Sleeve™, 12- through 60-inch (100 – 1500 mm), is a stainless steel grouting sleeve that is installed with an inflatable plug. The sleeve may be used to seal a joint or repair short sections of damaged pipe. The manufacture should be contacted to verify the product meets the specific application requirements including test requirements, if specified.

Internal chemical sealing is another method of internal joint repair using chemically activated gel or grout to minimize joint leakage. The grout is typically applied with specialized remote-controlled equipment. Test/seal packer is used to remotely seal a joint. The grouting chemicals are forced through the joint out into the surrounding soil where they gel with the soil. The gelled mass forms a waterproof collar around the pipe. The result is significantly reduced leakage. There are several types of chemical grouts available and the manufacturer should be contacted to review the specific situation and any joint tightness or pressure test criteria. Companies such as Avanti International, Strata Tech Inc., and Carylton Corporation manufacture and/or install chemical grout. Stephen's Technologies *New Life Coatings* and *NewLife Liner Systems* as well as Avast Hydro-Lining International, are examples of companies that offer cured in place epoxy lining systems that have been effectively used with HDPE pipe. Most pipe diameters can be chemically grouted provided the grouting contractor has the appropriate equipment.

Manufacturer Contact Information

Contact the Regional Engineer or Application Engineering Department for assistance with other unique conditions or for contact information regarding any companies listed in this technical note.

Note: Thermoplastic pipe products are solely intended for the conveyance of fluids. Access into this product for maintenance, inspection, repair, or other reason should be done in strict accordance with OSHA recommendations for confined space entry.



Technical Note

TN 5.17 Post Installation Testing of SaniTite® HP

Introduction

Sanitary sewer is often tested after or during installation to ensure a sound installation was accomplished. Types of post installation field testing include deflection testing and joint testing. Specific testing required for the project will be found in the project specifications. This technical note is not meant to supersede any project specification, but should be used in conjunction with the project specification and national testing standards as it relates specifically to SaniTite HP pipe.

Deflection Testing

An important feature of any flexible pipe is its ability to deflect, or oval, under load without structural distress. Deflection allows the load to be transferred from the pipe to the surrounding backfill. The result is flexible pipe can withstand very high loads as a relatively light structure. Flexible pipe – including SaniTite HP – *must* deflect in order to mobilize the strength of the surrounding backfill.

According to current thermoplastic design procedures, deflection is defined as a service limit. The designer, considering all site conditions, will set this service limit in order to perform a proper design evaluation. Deflection in excess of this service limit does not necessarily result in strength limits being exceeded, i.e. system failure. For more information on service and strength limit states, see the *Structures* section of the Drainage Handbook. SaniTite HP can be expected to perform satisfactorily in most applications with 5% or 7.5% deflection and so it is typical of designers to choose a service limit in this range.

When testing for allowable deflection limits, the minimum inside diameter should be used when establishing mandrel sizing. The minimum inside diameter accounts for the allowable manufacturing tolerances. Table 1 lists the inside diameters that result from 5% and 7.5% deflection from the minimum inside diameter. Values listed in Table 1 should be used for sizing mandrels for deflection testing. Mandrels may be obtained from a variety of commercial suppliers.

Table 1
SaniTite HP Recommended Mandrel Settings

Pipe Type	Pipe Diameter	Minimum Inside Diameter	Inside Diameter with 5% Deflection	Inside Diameter with 7.5% Deflection
Dual Wall	12	11.90	11.31	11.01
	15	14.85	14.11	13.74
	18	17.93	17.03	16.59
	24	23.90	22.71	22.11
	30	29.79	28.30	27.56
Triple Wall	30	29.62	28.14	27.40
	36	35.40	33.63	32.75
	42	41.31	39.24	38.21
	48	47.31	44.94	43.76
	60	59.30	56.34	54.85

It is important to understand that mandrel testing is a go/no-go test. If any line were to not pass a mandrel, it is important to ascertain the cause. Obstructions in the line, not associated with deflection, may influence the test. Visual inspection is recommended in the event of a no-go result.



Joint Testing

Joint testing is an important part of any sanitary sewer system, both in testing for infiltration and exfiltration. Infiltration aids to estimate the amount of sewer water that will be conveyed to, and ultimately treated by, the waste water treatment plant. Exfiltration aids to estimate the loss of sewage water into the surrounding soil. The two primary ways of testing sewer pipe joints for infiltration and/or exfiltration is using air or water to create a constant pressure within the system.

Exfiltration Testing with Air

Air is a compressible gas and so it is extremely important one adheres to the appropriate safety regulations outlined in OSHA and project specifications. There are two primary national testing standards that may be applied to joint testing SaniTite HP: ASTM F1417 *Standard Test Method for Installation Acceptance of Plastic Gravity Sewer Lines Using Low-Pressure Air*, and ASTM F3058 *Preliminary Field Testing of Thermoplastic Pipe Joints for Gravity Flow (Non-Pressure) Sewer Lines*. When either standard is specified by the project plans, one should review the standards carefully and follow the testing procedure and safety precautions outlined. The below commentary on the ASTM testing procedures should be considered a summary and does not replace the testing procedures outlined in their respective specifications.

ASTM F1417 entails testing a run of pipe from one manhole to the next adjacent manhole. Inflatable plugs are positioned into the manholes and secured. Air is introduced into the pipe line and gradually builds pressure. Once the line has been pressurized and is stable at 4.0-psi, the pressure is decreased to 3.5-psi at which time the line must not lose more than 0.5- or 1.0-psi (whichever is specified by the design engineer) in the specified amount of time. Table 2 below summarizes the minimum time that must be reached for less than 0.5- or 1.0-psi of pressure drop, depending on the diameter and length of pipe being tested.

Table 2
Time to Pressure Drop for SaniTite HP (per ASTM F1417)

Pipe Diameter	Pressure Drop (psi)	Minimum Test Time (min:sec)	Length for Minimum Time, (ft)	Time for Longer Lengths, (sec)	Time for Length Shown, (min:sec)							
					100 ft	150 ft	200 ft	250 ft	300 ft	350 ft	400 ft	450 ft
12	0.5	5:40	199	1.709 L	5:40	5:40	5:42	7:08	8:33	9:58	11:24	12:50
	1.0	11:20		3.418 L	11:20	11:20	11:24	14:15	17:05	19:56	22:47	25:38
15	0.5	7:05	159	2.671 L	7:05	7:05	8:54	11:08	13:21	15:35	17:48	20:02
	1.0	14:10		5.342 L	14:10	14:10	17:48	22:15	26:42	31:09	35:36	40:04
18	0.5	8:30	133	3.846 L	8:30	9:37	12:49	16:01	19:14	22:26	25:38	28:51
	1.0	17:00		7.692 L	17:00	19:13	25:38	32:03	38:27	44:52	51:16	57:41
24	0.5	11:20	99	6.837 L	11:24	17:57	22:48	28:30	34:11	39:53	45:35	51:17
	1.0	22:40		13.764 L	22:47	34:11	43:34	56:58	68:22	79:46	91:10	102:33
30	0.5	14:10	80	10.683 L	17:48	26:43	35:37	44:31	53:25	62:19	71:13	80:07
	1.0	28:20		21.366 L	35:37	53:25	71:13	89:02	106:50	124:38	142:26	160:15

Data taken from ASTM F 1417¹ and Uni-Bell, Uni-B-6-98³.

It may not be necessary to hold the test for the entire time period listed above when it is evident that the rate of air loss is zero or less than the allowable pressure drop and authorized by the approving authority¹.

When the pipe is large enough to be physically accessed, it may be desirable to test individual joints for safety reasons. In these cases, one may consider joint testing in accordance with ASTM F3058, also known as a joint isolation test. ADS recommends a joint isolation test, in lieu of a full line test, for testing pipe diameters 36" and larger for safety reasons. This test is typically done with air, though water may also be used, and involves the use of special testing equipment. The equipment consists of two inflatable bladders, placed on each side of the joint, creating an open center cavity between them. The bladders are inflated and then the center cavity is pressurized to 3.5 psi. The joint passes the test if the pressure is held for 5 seconds without dropping more than 1.0-psi. For all practical purposes, this is a go/no-go test. Final acceptance of the pipeline per this testing method shall be at the discretion of the Design Engineer. One advantage of this type of test is the ability for the installer to quickly test the joint immediately after installation, allowing for any corrective measures to be taken early on in the project.

Infiltration/Exfiltration with Water

Testing sanitary sewer joints via water infiltration or exfiltration is a common practice. For SaniTite HP, this testing should be conducted in accordance with ASTM F2487 *Standard Practice for Infiltration and Exfiltration Acceptance Testing of Installed Corrugated High Density Polyethylene Pipelines*. These standards entail first observing the ground water conditions and, if applicable, measuring the infiltration rate of the ground water through the joints. If ground water is not applicable, then the line is filled with water and the leakage is observed through exfiltration.

For the infiltration test the ground water must be at least 2 feet above the crown of the pipe for the entire test section. If this groundwater condition is not present, exfiltration testing should be used. Measure the groundwater elevation and determine the average head, relative to the pipe invert, over the test section. All outlets discharging into the upstream manhole shall be plugged. Measure the infiltration leakage at the outlet of the test section. The leakage may be small and is best measured by timing the filling of a container of known volume or by directing the flow into a container for a specified time and measuring the volume. Weirs may also be used to measure the flow.

Exfiltration testing is appropriate when the groundwater condition is less than 2 feet above the crown of the pipe measured at the upstream end. All outlets discharging into the upstream end of the test section as well as the downstream end shall be plug. At the upstream manhole the test head shall be established at a minimum of 2 feet above the crown of the pipe or 2 feet above the existing ground water condition, which ever is higher. The leakage shall be measured over a timed test period of not less than 15 minutes and no more than 24 hours. Leakage may be measured through observation in a water column or by adding water at a known rate to satisfy a constant water elevation.

Manholes shall be tested separately and independently of the pipe line to the requirements established in the project specifications. When water level is measured in the manhole for the exfiltration test, the leakage associated with the manhole shall be subtracted from the overall leakage of the test section to establish a pass or fail grade for the pipe.

Allowable Leakage

The allowable leakage rate for SaniTite HP is 50 gallons/in-dia/mi-pipe/day for both infiltration and exfiltration when done in accordance with ASTM F2487

Conclusion

ADS SaniTite HP is intended for gravity flow sanitary sewer applications and may be tested for deflection and joint tightness as discussed in this technical document. It is important to note that the testing procedures are no different than for other sanitary sewer products currently being used in the market. This document does not purport to address the safety concerns associated with testing SaniTite HP. Any questions associated with testing SaniTite HP can be directed to your local representative.

References

1. ASTM F1417, *Standard Test Method for Installation Acceptance of Plastic Gravity Sewer Lines Using Low-Pressure Air*, ASTM, 2005
2. *F3058, Preliminary Field Testing of Thermoplastic Pipe Joints for Gravity Flow (non-Pressure) Sewer Lines*, ASTM, 2016.
3. Uni-B-6-98, *Recommended Practice for Low-Pressure Air Testing of Installed Sewer Pipe*, Uni-Bell PVC Pipe Association, 1998
4. ASTM F2487, *Standard Practice for Infiltration and Exfiltration Acceptance Testing of Installed Corrugated High Density Polyethylene Pipelines*, ASTM, 2006



Technical Note

TN 5.18 Lining of Casings with SaniTite® HP Pipe

In sanitary sewer, it is often necessary to use trenchless technology methods to install a casing pipe under high volume roads, railroads or other sensitive areas where the ground surface cannot be disturbed. Methods of installing the casing pipe will vary based on the native soil conditions, groundwater location, length of installation and the precision required for the pipe line and grade. SaniTite HP is not designed to withstand the high compressive or tensile forces associated with trenchless placement; however SaniTite HP pipe can be used as a carrier pipe within a casing, provided open pits are used at each end of the tunnel operation to prevent bending of the pipe in place. When short sections of sanitary sewer require trenchless placement, commonly a smooth-walled steel pipe with protective coating is used as the casing pipe, with its wall thickness dependent on anticipated loading conditions as well as regional specifications. Common placement methods for steel casings include horizontal auger boring (HAB) or pipe jacking, but the casing placement method does not necessarily impact the carrier pipe installation, as long as adequate access is provided.

Sizing of the Casing Pipe

In some cases, the diameter of the casing pipe may be limited by the in-situ conditions, such as proximity to bedrock or the presence of weak native soils. Where in-situ conditions are not the limiting factor in casing sizing, the smallest possible diameter pipe is often desired and is contingent upon the carrier pipe's outside diameter, additional conduits, and support/bracing system required for the carrier pipes. Table 1 provides the maximum possible pipe outside diameter.



Table 1
Dimensions of HP Pipe Products

	Nominal Inside Diam. in (mm)	Max Outside Diam.* in (mm)		Nominal Inside Diam. in (mm)	Max Outside Diam.* in (mm)
Dual Wall	12 (300)	14.6 (371)	Triple Wall	30 (750)	35.7 (907)
	15 (375)	17.8 (452)		36 (900)	41.7 (1059)
	18 (450)	21.5 (546)		42 (1050)	47.5 (1207)
	24 (600)	28.2 (716)		48 (1200)	54.3 (1379)
	30 (750)	35.5 (902)		60 (1500)	67.2 (1707)

* Contact ADS for additional guidance if anticipated OD values provided may not provide adequate clearance.

To ensure consistent line and grade over the life of the sanitary sewer, the pipeline is braced in the casing to prevent movement. Bracing systems can range from field-installed skids banded to the exterior of the pipe to manufactured casing spacers installed incrementally along the carrier pipe. The bracing system and the diameter of the casing are dependent on each other, where a specific casing spacer type may require a larger clearance around the carrier pipe, or vice-versa where a casing pipe diameter may limit the type of bracing that can be used. Additional information on bracing systems and installation is the *Casing Spacers and Skids* section of this document. No matter what bracing system may be used, minimum 1-inch should be left between the inside of the casing and the outside of the bracing. This clearance helps prevent the pipe/spacer system from getting wedged in the casing due to warped casing pipe or imperfections caused during trenchless operations.

Structural Requirements

In the case of trenchless casing pipe installations, the casing pipe being installed is typically designed such that the live and dead loads are carried solely by the casing pipe with no load being transferred to the carrier pipe. For cases where a deteriorating pipe is being sliplined or the design requires a load to be carried by the sewer pipe within the casing, pipe suitability is often evaluated as if the casing pipe were not present and fill height and live loading recommendations are followed in the same manner as open-cut trench installations.

Installation Techniques

Often times the length of sewer section requiring a casing is less than 300ft when road or rail crossings are relatively narrow. For these circumstances, a typical method simply involves joining successive carrier pipe joints together outside of the casing while pushing the carrier pipe through the casing. It is recommended that a push stub or large blocking surface be used to push the pipe through the casing to avoid point loads damaging the pipe end.

A second method involves passing a cable through the casing and the first stick of pipe to pull the pipe in place. On the opposite end of the pipe a suitable cross piece is installed as well as protection for the pipe joint (push stub). The cable is pulled through the casing by a winch or other mechanical equipment thus bringing the carrier pipe inside the casing. Once a majority of the first pipe is inside the casing, the cross piece is disassembled and attached to the next pipe, joints are assembled and the operation begins again. See Figure 2 for an illustration of this method.

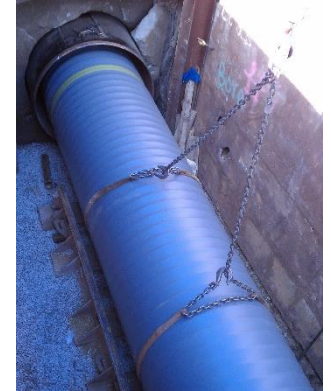

**Figure 2
Pulling HP Pipe in Casing**

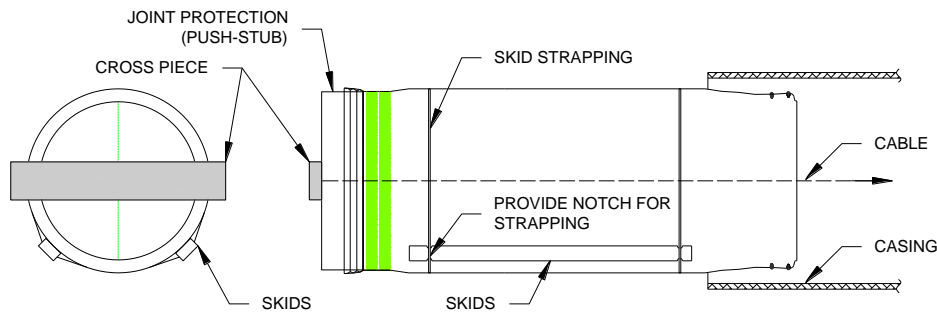

Using casing spacers will help minimize the resistance between the two surfaces, possibly allowing for longer installations. Table 2 provides the maximum recommended thrust force on the joint. While push length values are provided for reference, specific installation conditions, including the casing pipe and spacer/blocking materials, will impact the allowable push length.

**Table 2
Maximum Push Force on HP Products**

Nominal Inside Diam., in (mm)	Max Thrust Force, lbs (kN)	Push Length ¹ , ft (m)
12 (300)	1,500 (6.7)	400 (121)
15 (375)	2,000 (8.9)	400 (121)
18 (450)	3,000 (13.3)	400 (121)
24 (600)	4,500 (20.0)	400 (121)
30 (750)	4,500 (20.0)	400 (121)
36 (900)	9,000 (40.0)	300 (91)
42 (1050)	11,000 (48.9)	300 (91)
48 (1200)	12,000 (53.4)	300 (91)
60 (1500)	16,000 (71.2)	300 (91)

NOTES:
Push length is provided as general design guidance. Allowable push lengths should be calculated based on the project's installation conditions using the maximum thrust force values listed in this table. The push length values shown account for weight of HP pipe and a casing pipe w/ blocking resulting in a coefficient of static friction=0.7. Conditions or design values that vary from these assumptions will impact the actual thrust force on the joint and therefore the allowable push length.

Unlike some other pipe products where even short push lengths can cause over-homing, SaniTite HP does not require special joint blocks to be fabricated; however, joint restraints may aid in protecting the joint only when the joint thrust force may be high and longer installations are anticipated.

If maximum insertion forces are being exceeded, it is important to adjust the construction technique so as to not damage the carrier pipe. One solution is instead of joining adjacent pipes outside of the casing and pushing one long section, multiple, shorter sections are homed within the casing at the final location so as to avoid pushing the entire section of pipe. This technique can also be utilized when pulling sections into the casing as illustrated in Figure 3. It is important to note that access to the carrier pipe during joint assembly inside the casing is imperative for proper joint alignment.

Figure 3
Alternative Installation Method
(Used when maximum insertion forces are likely to be exceeded)

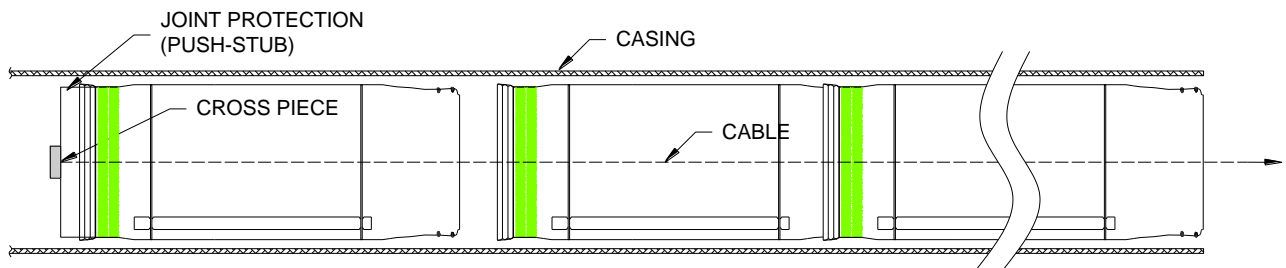

Casing Spacers and Skids

Skids may be attached to the carrier pipe to provide a sliding surface between the casing and the carrier pipe. It is important that the skids be notched where the straps are to provide a smooth sliding surface. Typically 2 to 4 skids are placed around the pipe. These skids run the length of the pipe, however should not be located in the spigot portion of the pipe as this may affect joint assembly. Wood blocks should never be wedged between the carrier pipe and the casing pipe.

Commercially available casing spacers may also be used to slide and guide the carrier pipe into the casing. When using dual wall sanitary pipe it is important that spacers be chosen that span at least two corrugations. Small sections of lumber may be used under the spacer to act as a bridge for the spacer to set on. Casing spacers are typically manufactured from polyethylene or a combination of stainless steel with polyethylene runners, but other non-corrodible materials are available. The benefits of using manufactured casing spacers include ease of installation with no banding tools needed, a lower coefficient of friction and ability to glide over rough spots or welded joints that may otherwise cause binding.

The casing spacer manufacturer should be contacted for exact sizing availabilities, but in general, molded plastic spacers provide shorter runner heights compared to stainless steel configurations. Other considerations including pipe diameter and weight will impact casing spacer selection. Because of the lightweight of SaniTite HP, molded plastic casing spacers can often withstand the weight expected from pipe and effluent in the system. Some casing spacer manufacturers are:



RACI (www.racispacers.com),
Cascade Waterworks Manufacturing
(www.cascademfg.com),
Pipeline Seal & Insulator, Inc (www.pipeline-seal.com), and
Advance Products & Systems, Inc. (www.apsonline.com)

Spacing between spacers or skids is a function of the long term unsupported settlement of flexible pipe. Commonly in sanitary sewer, hydraulics and prevention of depressions in the line are the primary considerations for determining an allowable grade deviation, not necessarily product deflection limitations. As a general guideline and as specified in some regions, the pipe grade should vary no more than 0.25-in from true grade. Based on this requirement, maximum unsupported distances for SaniTite HP 30"-60" pipe is 7ft and for 12"-24" pipe is 4ft. This recommendation is based on the conservative assumption that the sewer line will be flowing full for the duration of its service life. For cases where a specific settlement allowance exists or more accuracy is desired, Chart 1 below provides anticipated long-term settlement of the pipe under full-flow conditions based on spacer distance. If the necessary spacing cannot be achieved or is not practical, other methods to support the pipe invert may be used, including the use of skids in between supports or filling the void space with soil or grout material, at the discretion of the design engineer. Alternative design assumptions, such as lower flow capacities, will impact the anticipated settlement of the pipe and maximum unsupported length of pipe.

Chart 1
Unsupported Deflection of SaniTite HP

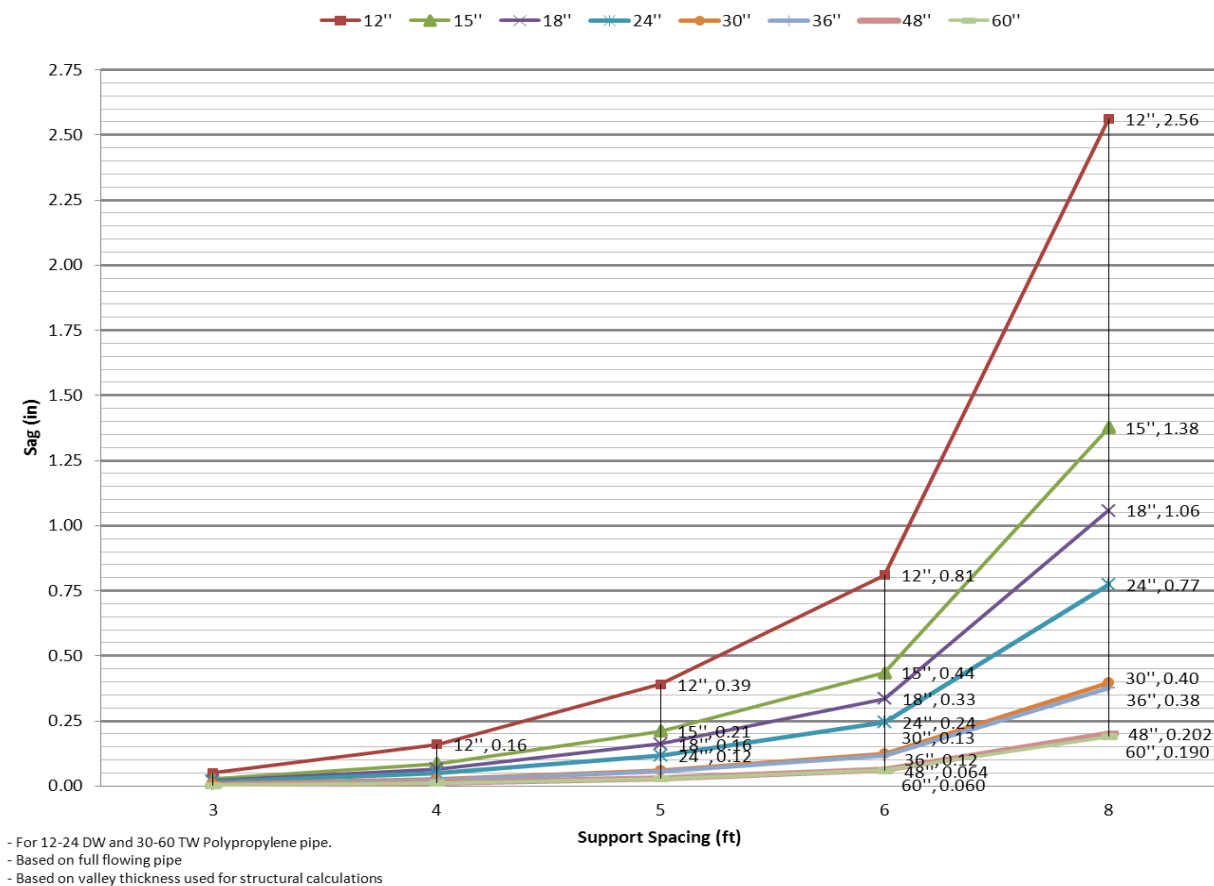

Closure After Pipe Installation

Any post-installation testing required for the sewer pipe should be successfully completed before any backfilling or closure operations begin.

Filling the void space between the carrier pipe and the casing pipe shall be done at the discretion of the engineer. In some cases, fill material may cause the load to be distributed to the carrier pipe and affect performance if not initially accounted for in structural design. Partial fill that supports the bottom ¼ of the pipe may sometimes be used if the invert of the pipe must be fully supported to ensure long-term grade elevation. Grout material, often a controlled low strength material (CLSM), also referred to as controlled density fill, CDF, or flowable fill is commonly utilized, with blown sand and gravel being other materials used to fill the void space as desired. CLSM will help provide uniform support on the sides of the pipe, maintain a consistent soil density, provide lateral support for the pipe, and eliminate point loads. For more information on flowable fill mix, refer to Technical Note 5.02: *Flowable Fill Backfill for Thermoplastic Pipe*. It is critical measures be taken to prevent flotation to maintain adequate line and grade of the carrier pipe. Grouting in layers thin enough, such that they don't float the pipe, helps tremendously.

Each layer should be allowed to set up between pours. Contractors may have other techniques that will also prevent flotation such as the use of deadweight inside the pipe. Regardless of the method used, it is also important to avoid applying point loads to the pipe. For more information on flotation and anchoring methods, refer to Technical Note 5.05: *Pipe Flotation*.

When SaniTite HP pipe, or any flexible pipe, is used as a liner, it is very important not to use excessive grout pressure. In most circumstances, the joint, not the wall strength, will be the limiting factor for establishing a maximum allowable grouting pressure. Including a factor of safety, the recommended maximum grouting pressure for HP pipe products is 5 psi; this value may vary based on specific site conditions and specific products used. During the grouting operation, gauges should be used to monitor the grout pressure exerted on the pipe system. For some applications, hydrostatic head pressure may increase the expected pressure on the pipe from the grouting. Additional pressure may also result from the slope and/or diameter of the pipe, elevation changes between the pipe and the gauge, and other conditions that should be considered during the design. The sum of all pressures that will be exerted on the pipe should not exceed the recommended maximum pressure for the application.



Once the carrier pipe has been successfully placed and tested within the casing pipe and any backfilling procedures are complete, the ends of the casing are typically sealed to prevent infiltration. Bricks, grout or manufactured rubber end seals are typical methods for sealing the ends of the casing pipe. For installations where a high hydrostatic load is anticipated, a watertight seal, such as a rubber boot, may be necessary to protect the carrier pipe.



The ADS logo and the Green Stripe are registered trademarks of Advanced Drainage Systems, Inc.
© 2022 Advanced Drainage Systems, Inc. TN 5.18 May 2022

adspipe.com
1-800-821-6710

References



SUMMARY OF CURRENT STANDARD SPECIFICATIONS USED IN THIS HANDBOOK

AASHTO STANDARDS

American Association of State Highway and Transportation Officials Standards

LRFD Section 12 – Buried Structures and Tunnel Liners

M43 – Sizes of Aggregate for Road and Bridge Construction

M190 – Bituminous-Coated Corrugated Metal Culvert Pipe and Pipe-Arches

M218 – Steel Sheet, Zinc-Coated (Galvanized), for Corrugated Steel Pipe

M245 – Corrugated Steel Pipe, Polymer-Precoated, for Sewers and Drains

M252 – Corrugated Polyethylene Drainage Pipe

M274 – Steel Sheet, Aluminum-Coated (Type 2), for Corrugated Steel Pipe

M289 – Aluminum-Zinc Alloy Coated Sheet Steel for Corrugated Steel Pipe

M294 – Corrugated Polyethylene Pipe, 300- to 1500-mm Diameter

M330 – Polypropylene Pipe, 300- to 1500-mm (12- to 60-in.) Diameter

Section 26 – Metal Culverts

Section 30 – Thermoplastic Pipe

ASTM STANDARDS

American Society for Testing and Materials Standards

A536-84 – Ductile Iron Castings

A924 – General Requirements for Steel Sheet, Metallic-Coated by the Hot-Dip Process

C969 – Infiltration and Exfiltration Acceptance Testing of Installed Precast Concrete Pipe Sewer Lines

D737 – Air Permeability of Textile Fabrics

D1056 – Flexible Cellular Materials – Sponge and Expanded Rubber

D1117 – Test Methods for Nonwoven Fabrics

D1149 – Rubber Deterioration – Surface Ozone Cracking in a Chamber

D1248-98 – Polyethylene Plastics Extrusion Materials for Wire and Cable

- D2321 – Underground Installation for Thermoplastic Pipe for Sewers and Other Gravity-Flow Applications
- D2412 – Determination of External Loading Characteristics of Plastic Pipe by Parallel-Plate Loading
- D2487 – Classification of Soils for Engineering Purposes
- D3034 – Type PSM Poly(Vinyl Chloride) (PVC) Sewer Pipe and Fittings
- D3212 – Joints for Drain and Sewer Plastic Pipes Using Flexible Elastomeric Seals
- D3350 – Polyethylene Plastics Pipe and Fittings Materials
- D3786 – Hydraulic Bursting Strength of Textile Fabrics – Diaphragm Bursting Strength Tester Methods
- D4101 – Polypropylene Injection and Extrusion Materials
- D4355 – Deterioration of Geotextiles by Exposure to Light, Moisture and Heat in a Xenon Arc Type Apparatus
- D4491 – Water Permeability of Geotextiles by Permittivity
- D4533 – Trapezoid Tearing Strength of Geotextiles
- D4632 – Grab Breaking Load and Elongation of Geotextiles
- D4751 – Determining Apparent Opening Size of a Geotextile
- D4833 – Index Puncture Resistance of Geotextiles, Geomembranes, and Related Products
- D5034 – Breaking Strength and Elongation of Textile Fabrics (Grab Test)
- D5199 – Measuring Nominal Thickness of Geotextiles and Geomembranes
- D5261 – Measuring Mass per Unit Area of Geotextiles
- F477 – Elastomeric Seals (Gaskets) for Joining Plastic Pipe
- F481 – Installation of Thermoplastic Pipe and Corrugated Pipe in Septic Tank Leach Fields
- F667 – Large Diameter Corrugated Polyethylene Pipe and Fittings
- F679 – Poly(Vinyl Chloride) (PVC) Large-Diameter Plastic Gravity Sewer Pipe and Fittings
- F794 – Poly(Vinyl Chloride) (PVC) Profile Gravity Sewer Pipe and Fittings Based on Controlled Inside Diameter
- F810 – Smoothwall Polyethylene (PE) Pipe for Use in Drainage and Waste Disposal Absorption Fields
- F949 – Poly(Vinyl Chloride) (PVC) Corrugated Sewer Pipe With a Smooth Interior and Fittings
- F1336 – Specification for Poly(Vinyl Chloride) (PVC) Gasketed Sewer Fittings

F1417 – Installation Acceptance of Plastic Gravity Sewer Lines Using low-Pressure Air

F2306 – 12 to 60in. Annular Corrugated Profile-Wall Polyethylene (PE) Pipe and Fittings for Gravity-Flow Storm Sewer and Subsurface Drainage Applications

F2487 – Standard Practice for Infiltration and Exfiltration Acceptance Testing of Installed Corrugated High Density Polyethylene Pipelines

F2649 – Standard Specification for Corrugated High Density Polyethylene (HDPE) Grease Interceptor Tanks

F2737 – Standard Specification for Corrugated High Density Polyethylene (HDPE) Water Quality Units

F2762 – 12 to 30 in. [300 to 750 mm] Annular Corrugated Profile-Wall Polyethylene (PE) Pipe and Fittings for Sanitary Sewer Applications

F2764 – 6 to 60 in. [300 to 1500 mm] Polypropylene (PP) Corrugated Double and Triple Triple Wall Pipe and Fittings for Non-Pressure Sanitary Sewer Applications

F2881 – 12 to 60 in. [300 to 1500 mm] Polypropylene (PP) Dual Wall Pipe and Fittings for Non-Pressure Storm Sewer Applications

F3058 – Standard Practice for Preliminary Field Testing of Thermoplastic Pipe Joints for Gravity Flow (Non-Pressure) Sewer Lines

CSA STANDARDS

B182.8-11 – Profile Polyethylene (PE) Storm Sewer and Drainage Pipe and Fittings

B182.11-11 – Standard practice for the installation of thermoplastic drain, storm, and sewer pipe and fittings

B182.13-11 – Profile Polypropylene (PP) Sewer Pipe and Fittings for leak-proof sewer applications

BNQ STANDARDS

1809-300/2007 – General Technical Specifications – Drinking Water And Sewer Lines

3624-110/2006 – Polyethylene (PE) Pipe Fittings- Semi-Rigid or Flexible Pipes for Surface Water Evacuation, Soil, Drainage and Culverts- Characteristics and Test Methods

3624-115/2007 – Polyethylene (PE) Pipe and Fittings- Flexible Pipes For Drainage- Characteristics and Test Methods

3624-120 – Polyethylene (PE) Pipe and Fittings- Smooth Inside Wall
Open Profile Pipes for Storm Weser and Soil Drainage-
Characteristics and Test Methods

3624-913-2013 – Polypropylene (PP) Pipe and Fittings- Certification
Protocol

COE STANDARDS

US Army Corp of Engineer Standards

02215-86 – Geotextiles Used as Filters

IAPMO STANDARDS

International Association of Plumbing and Mechanical Officials Standards

PS63-2004a – Plastic Leaching Chambers

SCS STANDARDS

Soil Conservation Service Standards

606 – Subsurface Drain

The following reference material may prove helpful in gaining additional information on polyethylene and storm drainage systems.

American Iron and Steel Institute. *Handbook of Steel Drainage and Highway Construction Products*. New York:AISI, 1971.

American Railway Engineering Association. *Manual for Railway Engineering*. Washington D.C.: AREA, 1984.

American Society of Civil Engineers. *Structural Plastics Design Manual* (ASCE Manuals and Reports on Engineering Practice No. 63). New York: ASCE, 1984.

American Society of Civil Engineering/Water Pollution Control Federation. *Gravity Sanitary Sewer Design and Construction*. New York: ASCE/WPCF, 1982.

Agricultural Research Service. "Structural Design Procedure for Corrugated Plastic Drainage Tubing - Technical Bulletin No. 1466." Washington D.C.: United States Department of Agriculture, 1973.

Atkins, Harold N. *Highway Materials, Soils, and Concrete*. Reston, VA: Reston Publishing Co., 1980.

Katona, Michael G. "Allowable Fill Heights for Corrugated Polyethylene Pipe." Transportation Research Board, 1987.

Katona, Michael G. "Minimum Cover for HDPE Corrugated Pipe - Phase 1." Corrugated Plastic Tubing Association, 1988.

Katona, Michael G. "Minimum Cover for HDPE Corrugated Pipe - Phase 1 and 2." Corrugated Plastic Tubing Association, 1989.

Spangler, Merlin G. and Handy, Richard L. *Soil Engineering*. New York: Harper and Row Publishers, 1982.



adspipe.com
800-821-6710

