

ANC[®] NON CONDUCTIVE FENCING



AMICO[®]
PERIMETER SECURITY

ANC® PERIMETER SYSTEM



AMICO Security developed the ANC® Non Conductive fence system as a total perimeter solution to offer a safe, aesthetically pleasing, non-conductive, radar friendly alternative to traditional fencing. ANC® is growing rapidly in popularity and has many applications and advantages.

- Savings: Can be less expensive than the overall installed cost of grounded chain link fence
- Security: M5 security rating in compliance with the ASTM standard
- Can be installed to meet any layout or grade changes
- Tested to be non-conductive
- 100% non-metallic and corrosion resistant
- Up to 20 ft high
- Can be retrofitted to existing metallic posts
- Pedestrian and vehicle swing and slide gates
- Cap sheets are available to deter climbing
- Panels are light enough for a 2-man crew

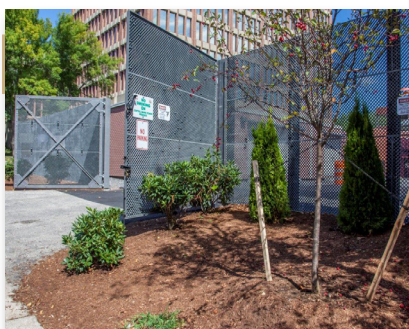

Best-In-Class Quality

With our 40 years of proven performance, choosing one of our corrosion resistant, fire retardant, non-conductive solutions is a safe choice for a "Best-in-Class" quality product. Based on 3rd party test reports, we can state our composite products are Heavy Metal free proving our commitment to the environment.



Power & Energy Sector

Secure substations, power facilities and energy companies throughout the world are becoming increasingly aware that ANC® is the best solution to eliminate unforeseen occurrences related to touch and step potential.

ANC® can help to ensure that the general population living around and that power employees who work around substations are safer. Dielectric tests have been conducted by a certified laboratory in which leakage current and flashover voltage tests revealed no electrical conductivity. As population centers evolve, the need for added safety and security is required.



Airports and Aviation Sector

As the need for airport security increases, AMICO has the answer. Airports throughout the globe are searching for Perimeter Systems that won't interfere with radar signals. While traditional high security metal fencing systems reflect radar, creating false images, ANC® fencing doesn't show this interference. In addition to being safe and secure, ANC® provides a clean aesthetically pleasing look that blends into the landscape.

ANC® Composite Security Fence System

The ANC® Composite Fence System combines non-conductivity and security into an easy to install solution for the energy, water, air, and transportation industries. The system can be installed as new or retrofit construction and steel posts can be used depending upon the recommendation from your grounding engineer. Metal posts and fittings are available.

Threaded fasteners bolt through the panels and tighten up securely using AMICO® panel plugs.

All fence components are available non-metallic and non-conductive.

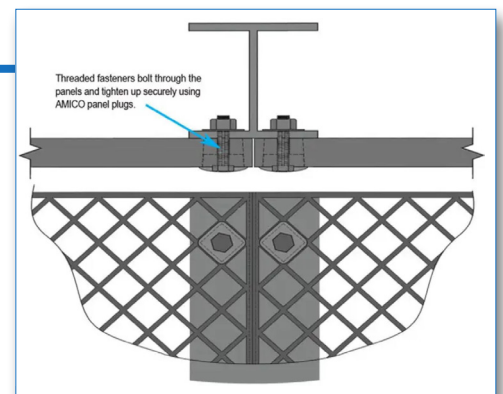

Environmental Durability

ANC® was primarily designed to survive wet, hot and humid conditions in the Gulf Coast and offshore. The material is fiberglass composite with UV inhibitors throughout, designed for extreme sun exposure and the highly corrosive environment

ANC® CHAMELEON® HYBRID SYSTEM



ANC® Chameleon® Hybrid System is a combination of ANC Non Conductive components on the outside and Chameleon Retrofit components on the inside.

- 100% non metallic, non-conductive from the outside
- M5 security rating in compliance with the ASTM standards
- Allows you to utilize existing fence posts
- Saves time (up to 40% over other fence systems) and materials
- Allows you to utilize existing grounding systems in place

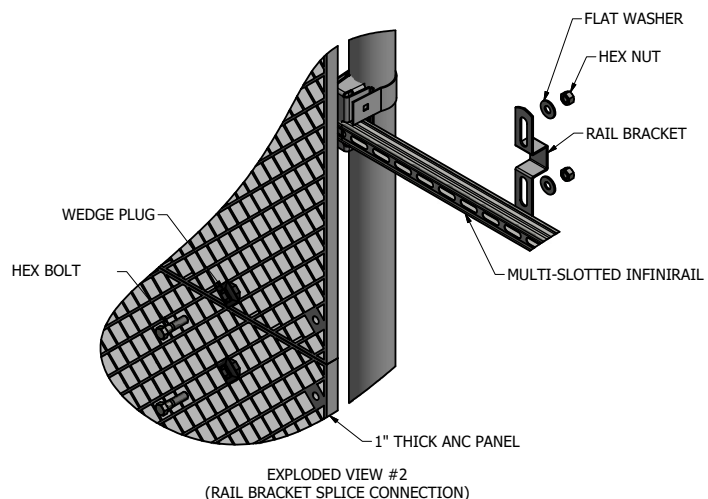
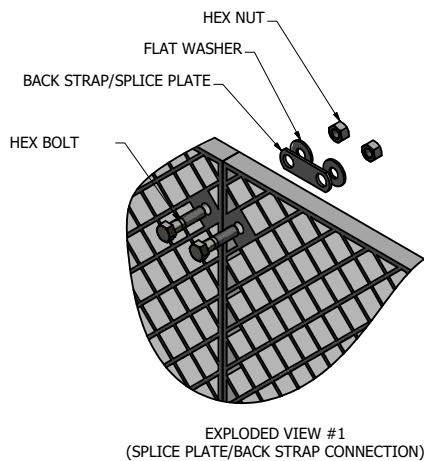
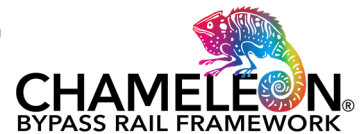

Installation of ANC® Chameleon® Hybrid System with ANC SAFEGUARD™ 2100 Mesh

AMICO Security offers a wide range of ANC SAFEGUARD™ Meshes. Mesh patterns range from our traditional diamond pattern to anti-climb and anti-breach square or rectangular patterns. All meshes offer a safe, aesthetically pleasing, non-conductive, radar friendly alternative to traditional security fencing.

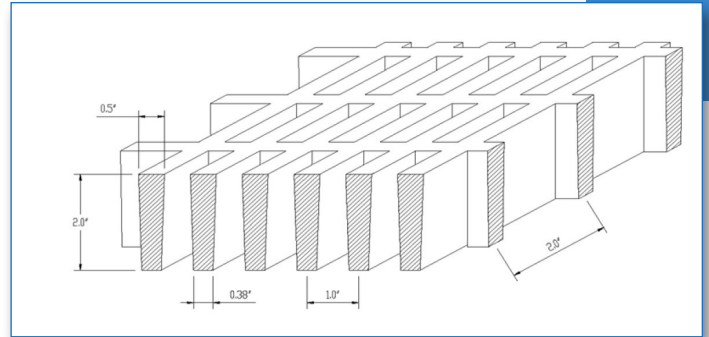

NEW ANC SAFEGUARD™ 4200 Mesh

ANC SAFEGUARD™ Mesh Style	Mesh Pattern	Nominal Dimensions Opening H x W (in)	Percent Open Area	Mesh Thickness (in)	Weight lbs per ft ²
ANC SAFEGUARD™ 1050	Diamond	2.25 x 2.25	72%	0.50	1.36
ANC SAFEGUARD™ 2100	Diamond	1.75 x 1.75	68%	1.00	2.36
ANC SAFEGUARD™ 3100	Square	0.50 x 0.50	44%	1.00	4.75
ANC SAFEGUARD™ 4200	Rectangular	0.50 x 1.50	48%	2.00	8.40
ANC SAFEGUARD™ 4225	Rectangular with solid backing	0.50 x 1.50	0%	2.25	10.40

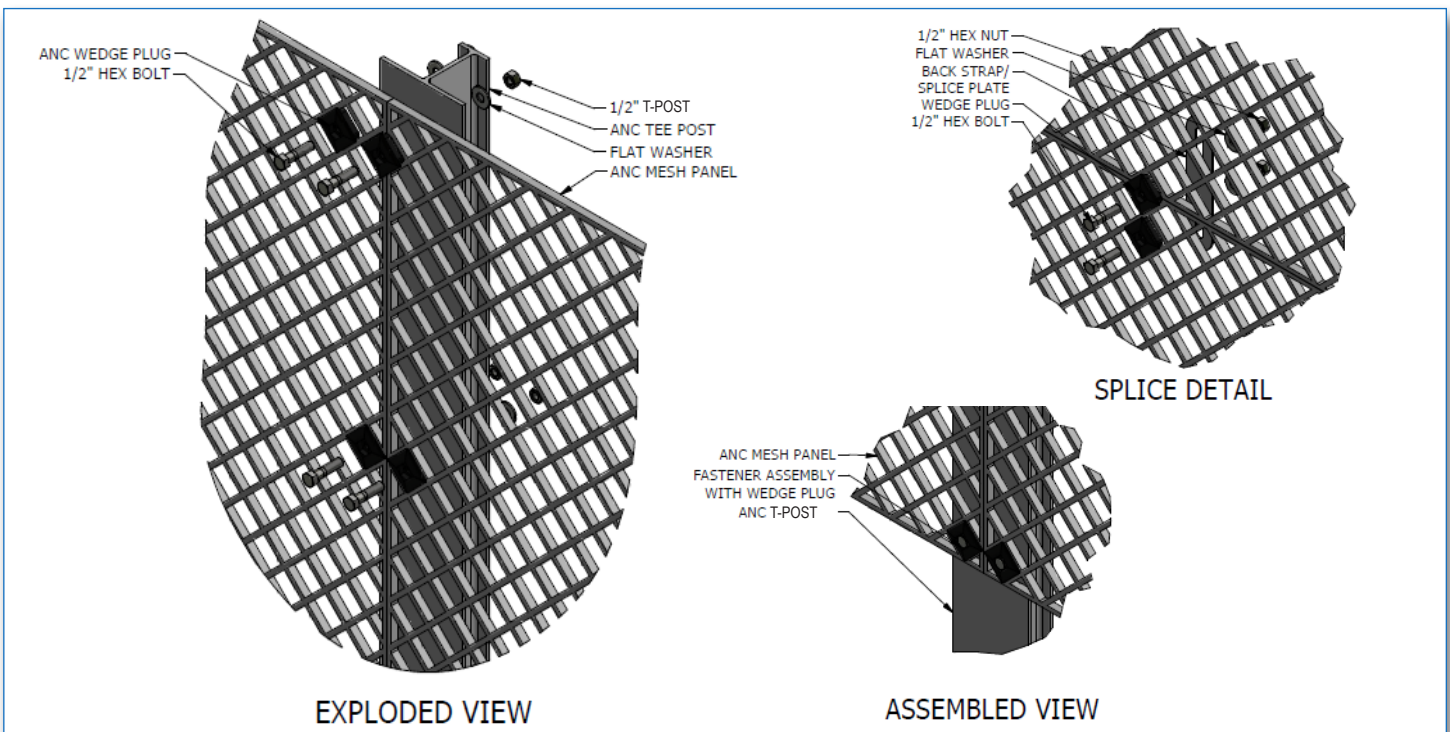

Installation of ANC SAFEGUARD™ 1050 & 2100 Meshes

ANC SAFEGUARD™ MESHES

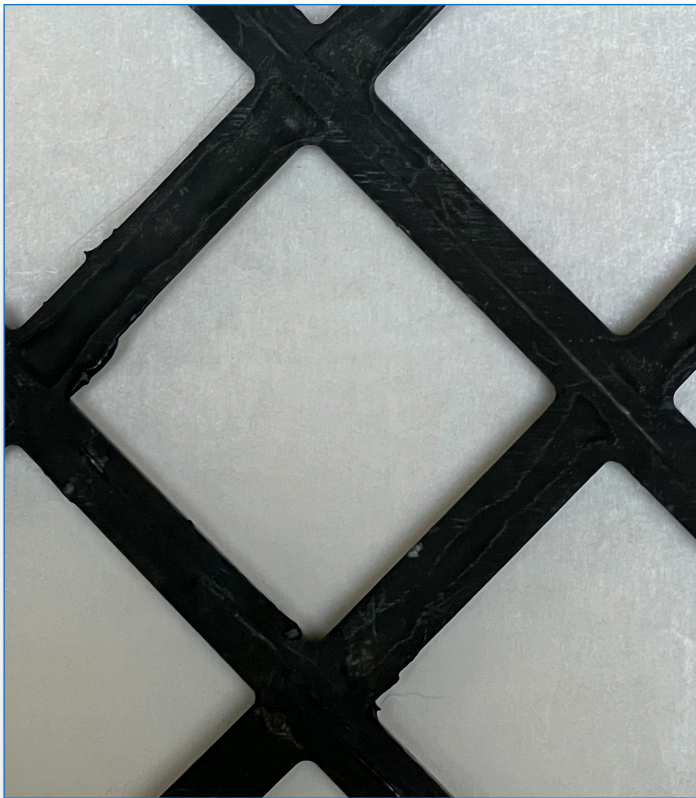

ANC SAFEGUARD™ 1050 Mesh



ANC SAFEGUARD™ 1050 Mesh

Samples shown in 1:1 scale



ANC SAFEGUARD™ 2100 Mesh

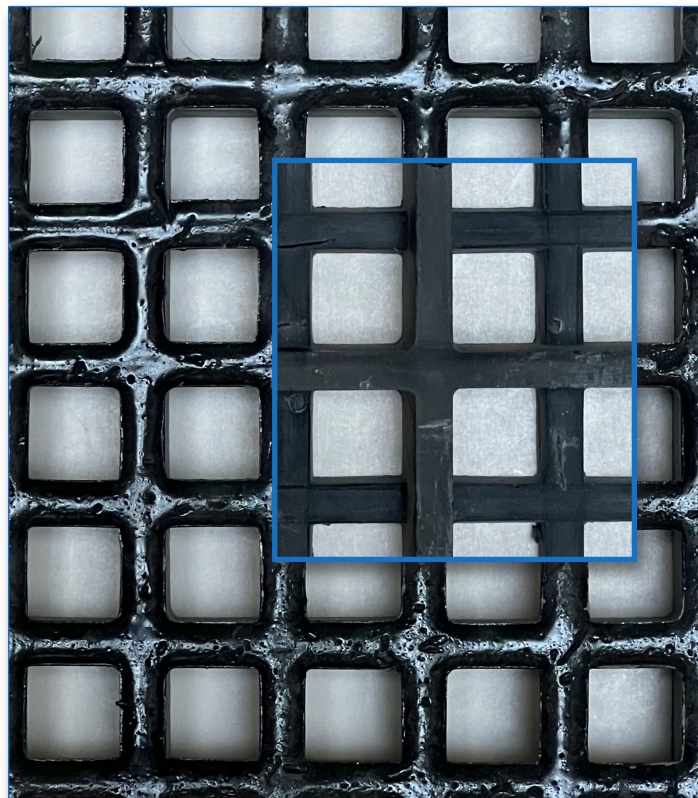

ANC SAFEGUARD™ 3100 Mesh (insert backside)



ANC SAFEGUARD™ 4200 Mesh



ANC Swing Gate with ANC SAFEGUARD™ 1050

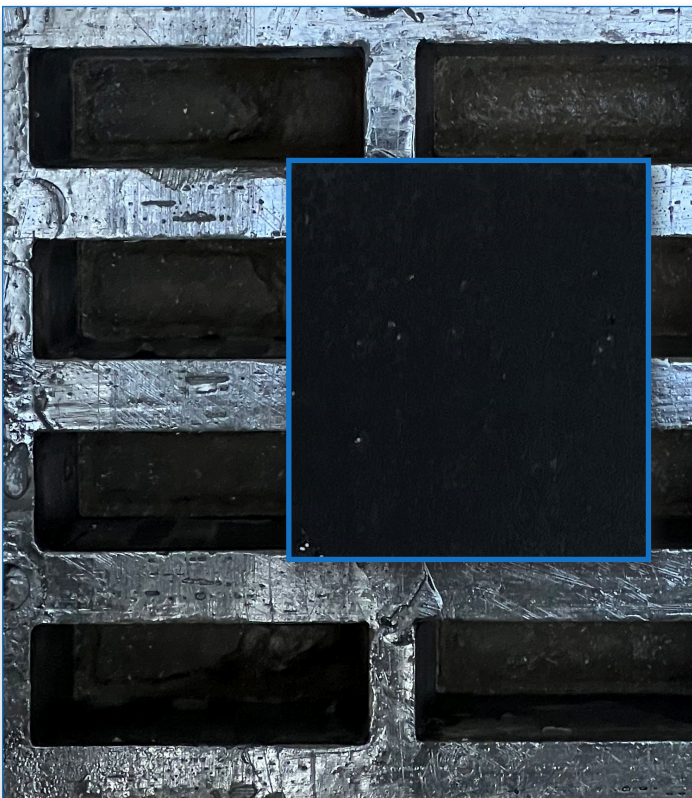

ANC SAFEGUARD™ 4225 Mesh (insert backside)



ANC SAFEGUARD™ 2100 Mesh

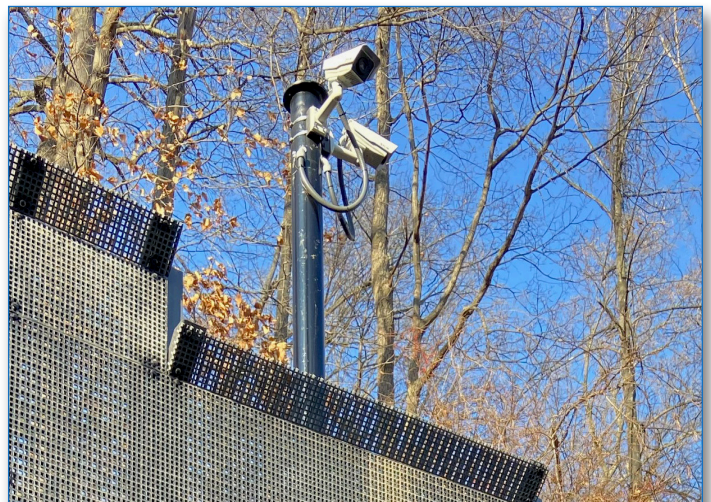

ANC SAFEGUARD™ 3100 Mesh

ANC SAFEGUARD™ 4200 Mesh



AMICO[®]
PERIMETER SECURITY

AMICO Security
3245 Fayette Avenue
Birmingham, AL 35208
855-552-6426

amicosecurity.com
info@amicosecurity.com
[linkedin.com/company/amicosecurity](https://www.linkedin.com/company/amicosecurity)