

### C-I Weep Trac™ Zinc Alloy Accessory

FOR CONTINUOUSLY INSULATED STUCCO AND STONE INSTALLATIONS

**SCOPE**

The 3½” nailing flange serves as flashing when weather resistant barriers or rainscreen is installed over the flange. The holes in the “trough” offer moisture weeping capabilities; over window and door heads, base of walls or other conditions that require drainage.

| Submitted Product                   | Product Number   | Product Dimensions |
|-------------------------------------|------------------|--------------------|
|                                     | CI-WT-Zinc Alloy | Per Drawing        |
| Standard Package Lengths are 10-ft. |                  |                    |

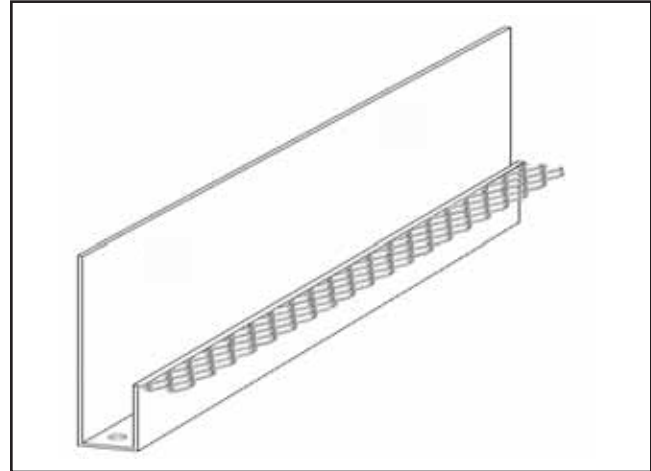

**DESCRIPTION**

This C-I Weep Trac™ is installed as part of a drainage system for Continuous Insulated stucco or stone applications. Corner beads may be used to return the scratch/finish coats into the wall.

**MATERIALS**

Zinc Alloy to ASTM B69 with a minimum thickness 0.020”.

AMICO recommends the selection of an appropriate type of material for accessories shall be determined by applicable surrounding climatic and environmental conditions specific to the project location, such as salt air, industrial pollution, high moisture, or humidity as stated in ASTM C1063.

**REFERENCES**

Meets IBC 2510 & IBC 2511 (Foundation Weep Screed)  
Refer to ASTM C1063 for support spacing, lath selection, fastener selection and further information regarding the proper installation of metal lath and accessories. Meets Buy American Procurement Requirements. Made in the United States of America.

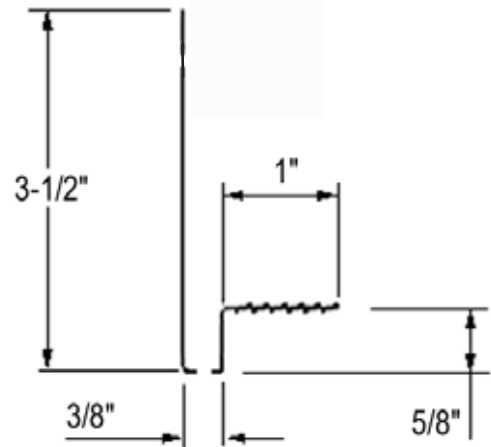

**FIRE TESTING:** The assembly including C-I Weep Trac™ meets NFPA 285-Standard Fire Test Method for Evaluation of Fire Propagation Characteristics of Exterior Non-Load-Bearing Wall Assemblies Containing Combustible Components.

**LEED DATA**

Both pre and post industrial recycled content are available – contact AMICO.  
LEED documentation requested from our website at [www.amico-lath.com//leed.htm](http://www.amico-lath.com//leed.htm)

All information contained herein is accurate as known at the time of publication. Specifications may change and AMICO reserves the right to change product specifications without notice and without incurring obligations.

**ALABAMA METAL INDUSTRIES CORPORATION**

3245 Fayette Avenue ♦ Birmingham, AL 35208 ♦ Telephone 800/366-2642 ♦ Facsimile 205/786-6527



# AMICO C-I Weep Trac™ Dimensional Drawing

Galvanized Steel  
Construction

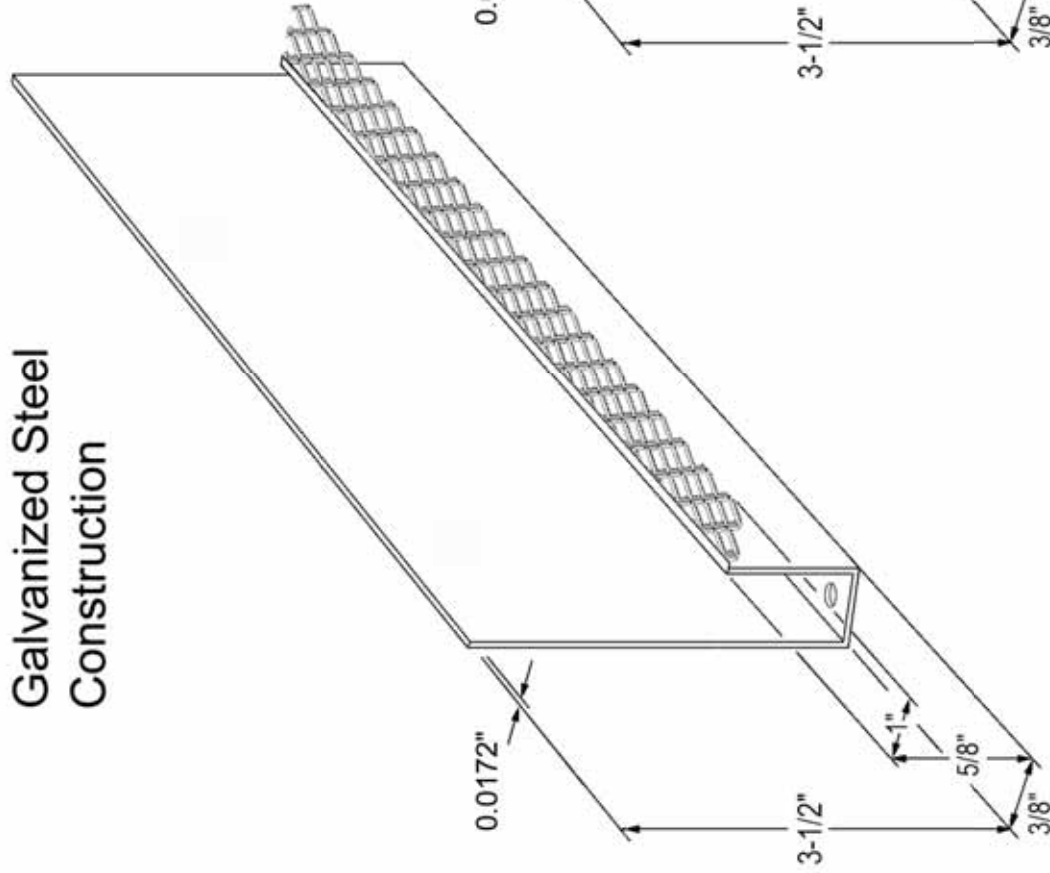

Zinc Alloy  
Construction

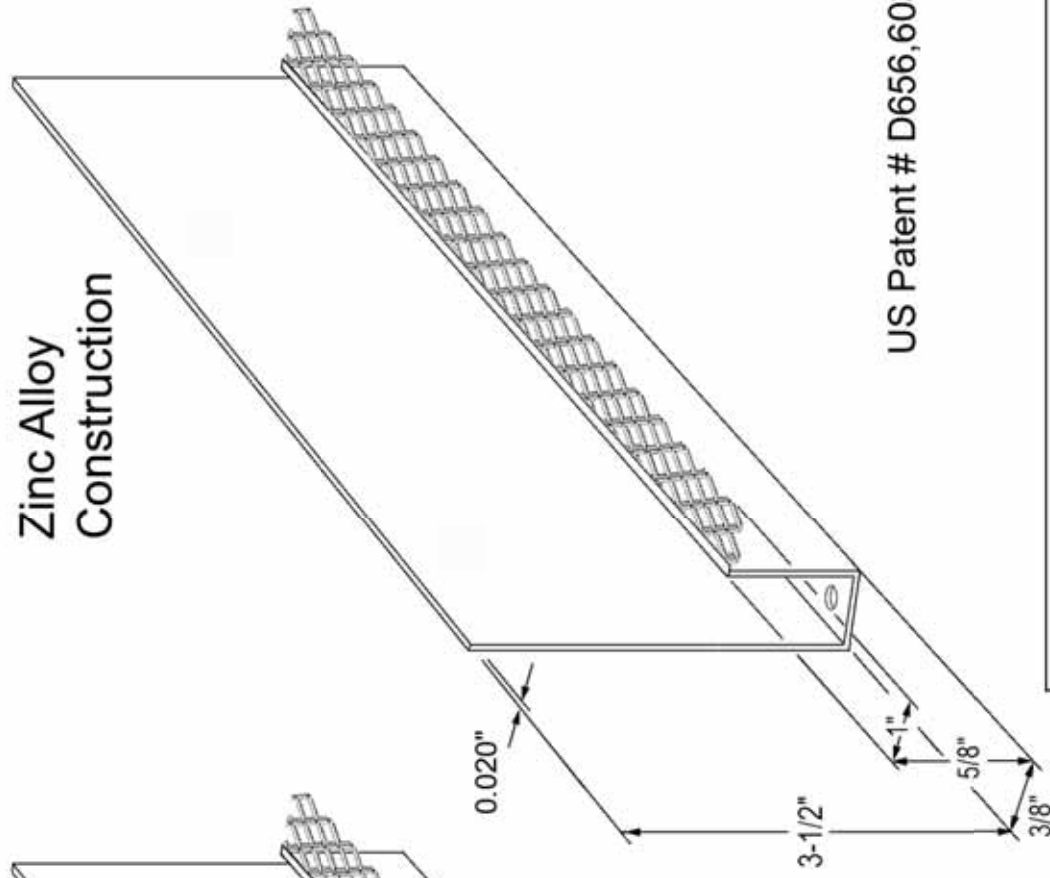

US Patent # D656,603



ALABAMA METAL INDUSTRIES CORPORATION  
3245 Fayette Avenue  
Birmingham, AL 35208  
800/366-2642