

Galvanized Steel Water Management Accessories for Stucco and Stone Installations

Project Submittals as manufactured by
ALABAMA METAL INDUSTRIES CORPORATION

Submittal Date:

Contract Number:

Project Name:

Section Number:

Contractor's Name:

All information contained herein is accurate as known at the time of publication. Specifications may change and AMICO reserves the right to change product specifications without notice and without incurring obligations.

ALABAMA METAL INDUSTRIES CORPORATION

3245 Fayette Avenue ♦ Birmingham, AL 35208 ♦ Telephone 800/366-2642 ♦ Facsimile 205/786-6527
email fmayer@gibraltar1.com



AMICO WATER MANAGEMENT Lathing Accessories

FOR STUCCO AND STONE INSTALLATIONS

SCOPE

This submittal covers formed sheet metal accessories. The selection of the accessory shall be determined by numerous factors not limited to: the project location, climate and environment resulting from excessive salt, moisture, humidity, pollution, wear and temperature changes.

MATERIALS

Galvanized Sheet Steel

THICKNESS OF BASE MATERIALS

These AMICO Water Management profiles are fabricated from minimum 0.018-inch thick.

FINISH

G-90 Galvanized Steel exceeds the minimum requirements of ASTM A924.

LEED

1.4 LEED CATEGORIES AND CREDITS

A. Material and Resources

1. MR Credit 4: 6.8% for recycled content
2. MR Credit 5: 25.5 for regional materials

DEFINITIONS

Expansion Joints (2-piece) shall be used to accommodate some degree of movement in the stucco membrane caused by movement of the building or its components to minimize damage to the stucco and weather resistive barrier.

Control Joints (1-piece), on the other hand, shall be installed to minimize stress due to stucco curing and drying shrinkage and minor movement, along predetermined, usually straight lines and as a screed to aid in stucco thickness control.

PACKAGING AND PACKAGE MARKING

Available in 10-ft long lengths. Longest possible lengths shall always be installed to avoid joints. Each factory box shall be marked with manufacturer's name, and style of lathing accessory.

CERTIFICATION

When required, a certification that products meets the requirements of ASTM A653 and ASTM C1063 shall be provided.

AMICO WATER MANAGEMENT ACCESSORIES MEETS THE FOLLOWING SPECIFICATIONS

ASTM A653 Standard Specification for Steel Sheet, Zinc-Coated (Galvanized) or Zinc-Iron Alloy-Coated (Galvannealed) by the Hot-Dip Process

ASTM A924

Standard Specification for General Requirements for Steel Sheet, Metallic-Coated by the Hot-Dip Process

ASTM C1063 Standard Specification for Installation of Lathing and Furring to Receive Interior and Exterior Portland Cement-Based Plaster

Made in the United States of America

Meets Buy American Procurement Requirements.

All information contained herein is accurate as known at the time of publication. Specifications may change and AMICO reserves the right to change product specifications without notice and without incurring obligations.

ALABAMA METAL INDUSTRIES CORPORATION

3245 Fayette Avenue ♦ Birmingham, AL 35208 ♦ Telephone 800/366-2642 ♦ Facsimile 205/786-6527
email fmayer@gibraltar1.com



M-SLIDE™-V (Vertical) GALVANIZED STEEL 2-PIECE EXPANSION JOINT

FOR STUCCO AND STONE INSTALLATIONS

This AMICO 2-piece expansion joint is for applications that require movement running vertically between stucco panels. Both pieces have a return ground lip which allows the stucco to key into the expansion joint reducing the chance for cracking along the edge of the accessory.

Product Submittal	Product Description	Ground	Weight per ft.
	M-Slide - V	7/8"	0.88 lb.
Standard Lengths are 10-Ft.			

FINISH

G-90 Galvanized Steel exceeds the minimum requirements of ASTM A924.

All butt joints, intersections, and ends should be joined, embedded and sealed in a quality sealant compatible with galvanized and exterior finishes.

ATTACHMENT

Use 1-1/4 inch long wafer head, self-taping screws per ASTM C954 allowing fastener to pass through, but not deform the accessory flange. Recommend one layer of WRB or peel-n-stick membrane behind the M-Slide flanges. Nails are not recommended as fasteners for M-Slide accessories.

REFERENCES

Refer to ASTM C1063 for support spacing, lath selection, fastener selection and further information regarding the proper installation of metal lath and accessories.

Meets Buy American Procurement Requirements
Made in the United States of America

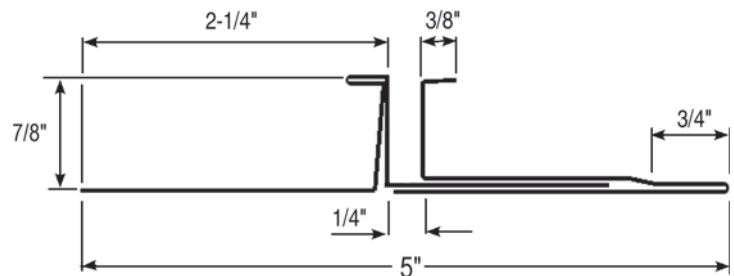
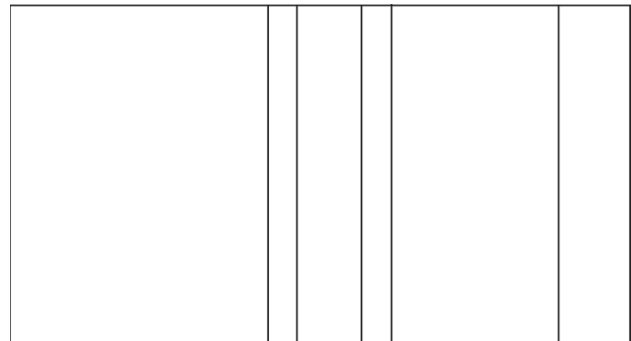
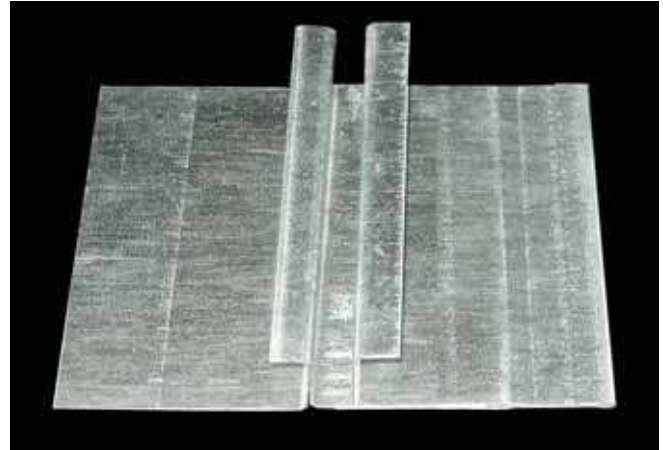

All information contained herein is accurate as known at the time of publication. Specifications may change and AMICO reserves the right to change product specifications without notice and without incurring obligations.

ALABAMA METAL INDUSTRIES CORPORATION

3245 Fayette Avenue ♦ Birmingham, AL 35208 ♦ Telephone 800/366-2642 ♦ Facsimile 205/786-6527
email fmayer@gibraltar1.com



M-SLIDE™-H (Horizontal) GALVANIZED STEEL 2-PIECE EXPANSION JOINT

FOR STUCCO AND STONE INSTALLATIONS

This AMICO 2-piece expansion joint is for applications between floor lines. The 45° slope allows water to weep out of the assembly. The lower component allows the wall to stay in alignment while also providing stucco movement capabilities to prevent stucco from cracking between floor lines.

Product Submittal	Product Description	Ground	Weight per ft.
	M-Slide - H	7/8"	1.1 lb.
Standard Lengths are 10-Ft.			

FINISH

G-90 Galvanized Steel exceeds the minimum requirements of ASTM A924.

All butt joints, intersections, and ends should be joined, embedded and sealed in a quality sealant compatible galvanized exterior finishes.

ATTACHMENT

Use 1-1/4 inch long wafer head, self-taping screws per ASTM C954 allowing fastener to pass through, but not deform the accessory flange. Recommend one layer of WRB or peel-n-stick membrane behind the M-Slide flanges and the second layer of WRB ship lapped over the top flange. Nails are not recommended as fasteners for M-Slide accessories.

REFERENCES

Refer to ASTM C1063 for support spacing, lath selection, fastener selection and further information regarding the proper installation of metal lath and accessories.

Meets Buy American Procurement Requirements
Made in the United States of America

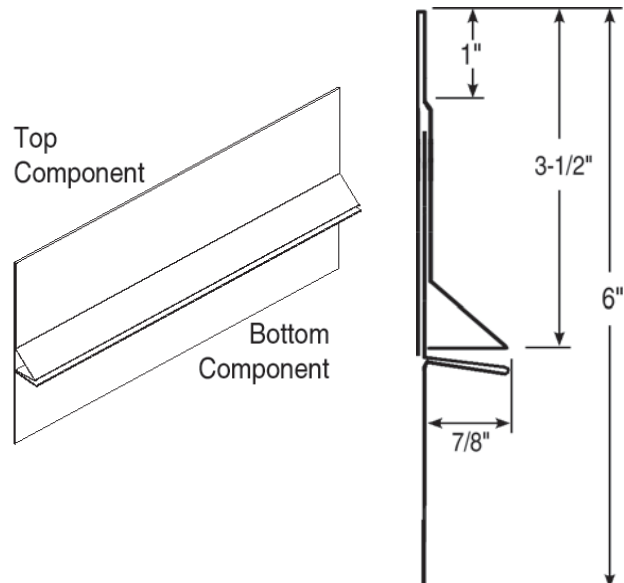

All information contained herein is accurate as known at the time of publication. Specifications may change and AMICO reserves the right to change product specifications without notice and without incurring obligations.

ALABAMA METAL INDUSTRIES CORPORATION

3245 Fayette Avenue ♦ Birmingham, AL 35208 ♦ Telephone 800/366-2642 ♦ Facsimile 205/786-6527
email fmayer@gibraltar1.com

