

Safety Grating

DIAMOND-GRIP®

PRODUCT DESCRIPTION

Diamond-Grip® is a one-piece metal plank grating manufactured by a cold forming process in the shape of a channel. The web of the channel is the walking surface and has rough serrated edges around diamond shaped openings. Diamond openings are complete with radiused corners at the saddle and side channel locations.

FEATURES & BENEFITS

- Serrated edges around diamond shaped openings provide slip resistance under slippery conditions such as snow, ice, grease, oil, etc.
- Radiused corners reduce the possibility of stress cracks across saddles or at the side channels under various loading conditions.
- Self-cleaning due to resilience of walking surface.
- One-piece metal construction.
- Lightweight design provides high strength to weight ratio.
- Long life span requiring little maintenance.
- Simple and economical installation as planks are self-framing.
- Adaptable to cost effective custom fabrication.
- Can be easily formed in standard channel or custom shapes.

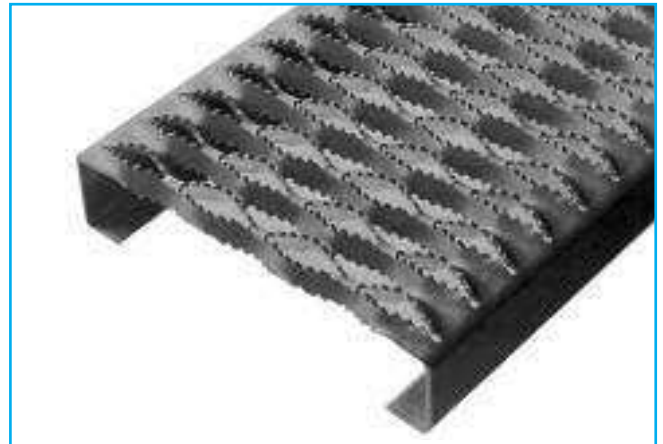

MATERIAL SPECIFICATIONS

Grating shall be "Diamond-Grip® channel," manufactured from (*see 'Selections' below*) and complete with a (1-1/2", 2", 2-1/2", 3") side channel depth, by AMICO.

SELECTIONS

- ASTM-A-653, G-90 (Z-275) Pre-galvanized 14 and 12 gauge steel.
- ASTM-A-1011, HRP&O 14 and 12 gauge steel.
- 5052-H32 Aluminum, .080" and .100" thick.
- Type 316L 2B Stainless Steel 14 gauge (up to 11-3/4" width).
- Type 304L 2B Stainless Steel 16 gauge (up to 11-3/4" width).

CHANNEL WIDTH "A"	RETURN FLANGE "B"	DIAMOND TO OUTSIDE "C"
4 3/4"	7/8"	5/16"
7"	1"	1/4"
9 1/2"	7/8"	1/4"
11 3/4"	1"	3/16"
18 3/4"	1"	3/16"
24"	1 1/8"	7/16"

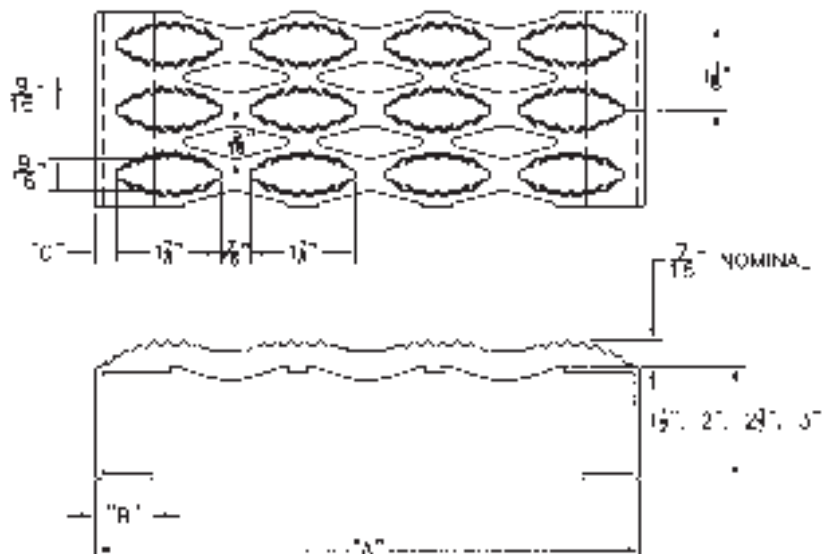

Note:

- Tolerances on all dimensions are $\pm 1/8"$
- Standard lengths are 121 1/2" & 144".
- Tolerance on manufactured and cut lengths is $\pm 1/8"$.
- When cutting Diamond-Grip®, AMICO® recommends cutting to full or half diamond increments. Contact sales for actual dimensions.
- Camber is an expected condition with sheet metal products. While ASTM allowance is generous, AMICO attempts to lessen the effects. Normal clearances should offset this phenomenon, however where tolerances warrant, contact AMICO for clarification.

Safety Grating

LOAD & DEFLECTION TABLES

Explanation of Load Type

- U = uniform load (lb/ft²)
- D = corresponding deflection (in) resulting from uniform load
- C = concentrated load (lb)
- D = corresponding deflection (in) resulting from concentrated load

Note:

- All UDL and concentrated loads include a safety factor of 1.67.
- Spans and loads to the right of the bold line, based on loads indicated, may exceed deflections of L/120.
- 2½" channel not shown in tables. Available by special request only.

4 3/4 Inch Wide - 2 Diamond

PRODUCT DETAILS				CLEAR SPAN ^{FT}																			
Type	Depth Weight	Catalog Number	lx IN.4 Sx IN.3	24"	30"	36"	42"	48"	54"	60"	66"	72"	78"	84"	90"	96"	108"	120"	132"	144"			
Steel 14 GA	1-1/2"	D2154	.267	U	1516	970	674	495	379	299	243	200	168										
				D	0.09	0.13	0.19	0.25	0.32	0.41	0.51	0.61	0.73										
	2.3 lb/ft			C	600	480	400	343	300	267	240	218	200										
				D	0.06	0.10	0.15	0.21	0.26	0.33	0.45	0.57	0.59										
	2"	D2204	.513	U	2236	1431	994	730	559	442	358	296	248	212	183	159	140	110	89				
				D	0.06	0.08	0.13	0.17	0.22	0.29	0.34	0.42	0.50	0.59	0.68	0.78	0.90	1.12	1.38				
2.5 lb/ft			C	885	708	590	506	443	393	354	322	295	272	253	236	221	197	177					
			D	0.06	0.07	0.10	0.14	0.17	0.23	0.27	0.33	0.40	0.46	0.54	0.63	0.71	0.90	1.11					
Steel 12 GA	1-1/2"	D2152	.125	U	1790	1147	798	587	451	357	290	240	203	173	150	131	116						
				D	0.07	0.10	0.15	0.20	0.27	0.34	0.42	0.51	0.61	0.71	0.83	0.96	1.09						
	3.0 lb/ft			C	708	568	474	407	357	318	287	262	241	223	208	195	184						
				D	0.05	0.08	0.12	0.16	0.21	0.27	0.33	0.41	0.48	0.57	0.66	0.77	0.88						
	2"	D2202	.263	U	2255	1445	1005	739	567	449	365	302	255	218	188	165	145	116	95	79	67		
				D	0.05	0.07	0.10	0.14	0.19	0.24	0.29	0.35	0.42	0.50	0.58	0.67	0.76	0.98	1.22	1.49	1.79		
3.3 lb/ft			C	892	715	597	512	449	400	361	329	303	280	261	245	230	206	188	172	160			
			D	0.04	0.06	0.08	0.11	0.15	0.19	0.21	0.28	0.34	0.40	0.46	0.53	0.61	0.78	0.97	1.19	1.43			
Alum .080"	2"	D2202A	.223	U	1398	895	622	457	350	277	225	186	156	133	115	101	89						
				D	0.09	0.14	0.20	0.27	0.36	0.45	0.56	0.68	0.81	0.95	1.11	1.27	1.45						
.93 lb/ft			C	553	443	369	317	277	247	222	202	186	172	160	149	140							
			D	0.07	0.11	0.16	0.22	0.29	0.36	0.45	0.54	0.65	0.76	0.88	1.02	1.16							
Stainless Steel 14 GA	2"	D2204S	.339	U	1730	1109	772	568	436	346	281	233	196	168	146	127	113						
				D	0.05	0.07	0.10	0.14	0.18	0.23	0.29	0.35	0.42	0.49	0.57	0.66	0.76						
2.5 lb/ft			C	685	549	458	394	345	308	278	254	233	216	202	189	178							
			D	0.04	0.06	0.08	0.11	0.15	0.19	0.23	0.28	0.33	0.39	0.46	0.53	0.61							

7 Inch Wide - 3 Diamond

PRODUCT DETAILS				CLEAR SPAN ^{FT}																	
Type	Depth Weight	Catalog Number	lx IN.4 Sx IN.3	24"	30"	36"	42"	48"	54"	60"	66"	72"	78"	84"	90"	96"	108"	120"	132"	144"	
Steel 14 GA	1-1/2"	D3154	.115	U	766	492	343	253	194	154	126	105	92								
				D	0.06	0.09	0.13	0.18	0.24	0.30	0.37	0.45	0.55								
	2.9 lb/ft			C	447	358	300	258	227	203	183	168	159								
				D	0.05	0.07	0.11	0.14	0.19	0.24	0.30	0.36	0.44								
	2"	D3204	.235	U	1374	881	613	451	347	275	223	185	156	134	116	101	90	72	59		
				D	0.05	0.08	0.11	0.15	0.20	0.25	0.31	0.38	0.46	0.54	0.63	0.72	0.83	1.06	1.32		
3.2 lb/ft			C	802	642	536	461	404	361	326	297	273	254	237	222	209	188	172			
			D	0.04	0.06	0.09	0.12	0.16	0.20	0.25	0.31	0.36	0.43	0.50	0.58	0.66	0.85	1.06			
Steel 12 GA	1-1/2"	D3152	.154	U	1304	836	582	428	329	261	212	176	148	127	110	96	85				
				D	0.07	0.11	0.16	0.22	0.29	0.36	0.45	0.55	0.65	0.77	0.90	1.04	1.18				
	3.9 lb/ft			C	761	609	509	437	384	342	309	282	259	240	224	210	198				
				D	0.06	0.09	0.13	0.17	0.23	0.29	0.36	0.44	0.52	0.62	0.72	0.83	0.95				
	2"	D3202	.313	U	1710	1096	762	561	430	341	277	230	194	165	143	125	111	88	72	60	51
				D	0.05	0.08	0.11	0.15	0.20	0.26	0.32	0.38	0.46	0.54	0.63	0.72	0.83	1.06	1.32	1.62	1.95
4.4 lb/ft			C	997	799	667	573	502	447	404	368	339	314	292	274	258	232	211	194	180	
			D	0.04	0.06	0.09	0.12	0.16	0.20	0.25	0.31	0.37	0.43	0.50	0.58	0.66	0.85	1.06	1.29	1.56	
3"	D3302	1.263	U	3247	2080	1446	1063	815	645	523	433	365	309	267	233	205	163	133	111	94	
			D	0.04	0.06	0.08	0.11	0.14	0.18	0.22	0.27	0.32	0.38	0.44	0.50	0.57	0.73	0.91	1.11	1.33	
5.1 lb/ft			C	1894	1516	1265	1086	951	847	763	695	639	585	545	510	479	428	388	355	328	
			D	0.03	0.04	0.06	0.09	0.11	0.14	0.18	0.22	0.26	0.30	0.35	0.40	0.46	0.58	0.73	0.89	1.06	
Alum .080"	2"	D3202A	.266	U	975	624	434	319	244	193	157	130	109	93	81						
				D	0.10	0.16	0.23	0.31	0.40	0.51	0.63	0.76	0.91	1.07	1.24						
1.2 lb/ft			C	568	455	380	326	285	254	229	208	191	177	164							
			D	0.08	0.13	0.18	0.25	0.32	0.41	0.50	0.61	0.73	0.85	1.00							
Stainless Steel 14 GA	2"	D3204S	.383	U	1819	1166	811	597	458	363	295	244	206	176	153	133	118				
				D	0.08	0.13	0.18	0.25	0.33	0.41	0.51	0.62	0.74	0.88	1.02	1.18	1.35				
3.2 lb/ft			C	1061	850	710	609	534	476	430	392	361	334	311	292	275					
			D	0.06	0.10	0.15	0.20	0.26	0.33	0.41	0.50	0.60	0.70	0.82	0.94	1.08					

Safety Grating

LOAD & DEFLECTION TABLES

9 1/2 Inch Wide - 4 Diamond

PRODUCT DETAILS				CLEAR SPAN ^{FT}																			
Type	Depth Weight	Catalog Number	Ix IN.4 Sx IN.3	24"	30"	36"	42"	48"	54"	60"	66"	72"	78"	84"	90"	96"	108"	120"	132"	144"			
Steel 14 GA	1-1/2"	D4154	.128	U	779	499	346	255	195	154	125	103	87										
				D	0.09	0.12	0.19	0.26	0.33	0.41	0.52	0.62	0.74										
				C	617	494	411	353	309	274	247	224	206										
	3.5 lb/ft	D4204	.264	U	1063	681	474	349	268	213	173	144	121	104	90	79	70	56	46				
				D	0.05	0.08	0.12	0.16	0.21	0.26	0.33	0.40	0.47	0.56	0.65	0.75	0.86	1.10	1.38				
				C	841	674	563	484	425	379	342	312	288	267	249	234	221	199	181				
3.7 lb/ft	D4204	.224	U	1063	681	474	349	268	213	173	144	121	104	90	79	70	56	46					
			D	0.04	0.06	0.09	0.13	0.17	0.21	0.26	0.32	0.38	0.45	0.52	0.60	0.69	0.88	1.10					
			C	841	674	563	484	425	379	342	312	288	267	249	234	221	199	181					
Steel 12 GA	1-1/2"	D4152	.172	U	988	634	441	325	249	198	161	133	113	96	84	73	65						
				D	0.08	0.12	0.17	0.23	0.30	0.39	0.48	0.58	0.69	0.82	0.95	1.10	1.26						
				C	782	627	524	450	395	352	318	291	268	248	232	218	205						
	4.8 lb/ft	D4202	.225	U	1063	681	474	349	268	213	173	144	121	104	90	79	70	56	46				
				D	0.06	0.09	0.14	0.19	0.24	0.31	0.38	0.46	0.55	0.65	0.76	0.88	1.01						
				C	841	674	563	484	425	379	342	312	288	267	249	234	221	199	181				
	2"	D4202	.354	U	1382	886	616	453	348	276	224	186	157	134	116	101	90	72	59	49	42		
				D	0.05	0.08	0.12	0.16	0.21	0.27	0.34	0.41	0.49	0.57	0.67	0.77	0.88	1.13	1.41	1.72	2.08		
				C	1094	876	732	628	551	491	443	404	372	345	321	301	284	255	232	213	198		
	5.1 lb/ft	D4302	.306	U	1540	887	687	506	388	307	250	207	175	149	129	113	100	80					
				D	0.04	0.07	0.10	0.13	0.17	0.22	0.27	0.33	0.39	0.46	0.54	0.62	0.71	0.89	1.13	1.38	1.66		
				C	1094	876	732	628	551	491	443	404	372	345	321	301	284	255	232	213	198		
3"	D4302	1.363	U	2270	1453	1009	741	567	548	444	367	308	263	226	197	173	137	111	92	77			
			D	0.04	0.06	0.08	0.11	0.14	0.22	0.28	0.33	0.40	0.47	0.54	0.62	0.70	0.89	1.10	1.35	1.60			
			C	1355	1355	1355	1255	1098	976	878	799	732	676	627	586	549	488	439	399	366			
5.8 lb/ft	D4302	.605	U	2270	1453	1009	741	567	548	444	367	308	263	226	197	173	137	111	92	77			
			D	0.02	0.04	0.07	0.11	0.15	0.18	0.22	0.27	0.32	0.38	0.43	0.49	0.56	0.71	0.89	1.04	1.27			
			C	1355	1355	1355	1255	1098	976	878	799	732	676	627	586	549	488	439	399	366			
Alum .080"	2"	D4202A	.300	U	800	512	356	261	200	158	128	106	89	76	65	57	50						
				D	0.12	0.19	0.27	0.37	0.50	0.62	0.76	0.94	1.12	1.30	1.49	1.73	1.97						
				C	633	507	422	362	317	282	253	230	211	195	181	169	158						
1.4 lb/ft	D4202A	.256	U	800	512	356	261	200	158	128	106	89	76	65	57	50							
			D	0.10	0.16	0.23	0.30	0.40	0.49	0.62	0.74	0.88	1.04	1.21	1.38	1.57							
			C	633	507	422	362	317	282	253	230	211	195	181	169	158							
Stainless Steel 16 GA	2"	D4206S	.143	U	750	480	330	240	186	147	120	99	82	70	58	47	39	27					
				D	0.06	0.09	0.13	0.18	0.24	0.30	0.37	0.45	0.53	0.63	0.70	0.75	0.80	0.90					
				C	455	455	398	341	299	265	239	217	199	184	171	159	149	133					
3.2 lb/ft	D4206S	.165	U	750	480	330	240	186	147	120	99	82	70	58	47	39	27						
			D	0.04	0.07	0.11	0.15	0.19	0.24	0.30	0.36	0.43	0.51	0.59	0.67	0.76	0.97						
			C	455	455	398	341	299	265	239	217	199	184	171	159	149	133						
Stainless Steel 14 GA	2"	D4204S	.401	U	1540	887	687	506	388	307	250	207	175	149	129	113	100	80					
				D	0.07	0.11	0.16	0.22	0.28	0.36	0.44	0.54	0.64	0.76	0.88	1.02	1.17	1.49					
				C	915	915	816	700	614	548	494	451	415	384	358	336	316	284					
3.7 lb/ft	D4204S	.287	U	1540	887	687	506	388	307	250	207	175	149	129	113	100	80						
			D	0.04	0.08	0.13	0.17	0.23	0.29	0.36	0.43	0.52	0.61	0.71	0.82	0.93	1.19						
			C	915	915	816	700	614	548	494	451	415	384	358	336	316	284						

11 3/4 Inch Wide - 5 Diamond

PRODUCT DETAILS				CLEAR SPAN ^{FT}																		
Type	Depth Weight	Catalog Number	Ix IN.4 Sx IN.3	24"	30"	36"	42"	48"	54"	60"	66"	72"	78"	84"	90"	96"	108"	120"	132"	144"		
Steel 14 GA	1-1/2"	D5154	.146	U	543	349	243	179	138	110	89	74	63									
				D	0.06	0.10	0.15	0.20	0.26	0.33	0.41	0.50	0.60									
				C	493	427	357	307	270	242	219	201	185									
	4.1 lb/ft	D5204	.178	U	895	574	400	295	226	179	146	121	102	87	75	65	57	45				
				D	0.05	0.08	0.12	0.16	0.21	0.27	0.33	0.40	0.48	0.57	0.66	0.76	0.86	1.09				
				C	493	493	493	493	443	395	357	326	299	276	259	239	224	199				
3.7 lb/ft	D5204	.247	U	895	574	400	295	226	179	146	121	102	87	75	65	57	45					
			D	0.02	0.05	0.08	0.13	0.17	0.22	0.27	0.33	0.39	0.46	0.53	0.60	0.69	0.87					
			C	493	493	493	493	443	395	357	326	299	276	259	239	224	199					
Steel 12 GA	1-1/2"	D5152	.195	U	842	540	376	276	212	168	137	113	95	82	71	62	55					
				D	0.08	0.13	0.18	0.25	0.32	0.41	0.51	0.62	0.73	0.87	1.01	1.16	1.33					
				C	815	661	552	474	415	370	334	305	280	260	242	227	214					
	5.7 lb/ft	D5202	.244	U	842	540	376	276	212	168	137	113	95	82	71	62	55					
				D	0.06	0.10	0.14	0.20	0.26	0.33	0.41	0.49	0.59	0.69	0.81	0.93	1.06					
				C	815	661	552	474	415	370	334	305	280	260	242	227	214					
	2"	D5202	.419	U	1243	797	554	408	313	248	200	166	139	119	102	89	78	62	50	41		
				D	0.06	0.09	0.13	0.18	0.23	0.29	0.36	0.44	0.52	0.61	0.72	0.82	0.92	1.19	1.44	1.75		
				C	815	815	814	699	613	545	491	446	409	378	351	327	307	273	245	223		
	6.1 lb/ft	D5302	.338	U	1666	1363	946	695	532	421	341	282	237	202	174	151	133	105	85	70	59	
				D	0.03	0.07	0.10	0.13	0.18	0.23	0.28	0.34	0.40	0.47	0.55	0.63	0.71	0.90				

Safety Grating

LOAD & DEFLECTION TABLES

18 3/4 Inch Wide - 8 Diamond

PRODUCT DETAILS				CLEAR SPAN ^{FT}																			
Type	Depth Weight	Catalog Number	lx IN.4 Sx IN.3	U	24"	30"	36"	42"	48"	54"	60"	66"	72"	78"	84"	90"	96"	108"	120"	132"	144"		
Steel 14 GA	1-1/2"	D8154	.178	U	411	263	182	134	103	81	66	54	46										
				D	0.08	0.11	0.18	0.24	0.31	0.39	0.49	0.58	0.70										
	5.9 lb/ft		.216	C	555	513	428	365	321	285	257	233	214										
				D	0.06	0.10	0.14	0.19	0.25	0.31	0.38	0.47	0.55										
	2"	D8204	.347	U	606	388	269	198	152	120	97	80	67		57	49	43	38					
				D	0.06	0.08	0.12	0.16	0.21	0.27	0.33	0.39	0.48	0.56	0.64	0.73	0.84						
6.1 lb/ft		.319	C	555	555	555	541	474	421	379	245	316		292	271	253	237						
			D	0.02	0.05	0.08	0.13	0.17	0.21	0.27	0.32	0.38	0.45	0.52	0.60	0.67							
Steel 12 GA	1-1/2"	D8152	.240	U	553	354	246	181	138	109	89	73	61	53	46	40							
				D	0.07	0.11	0.17	0.23	0.30	0.38	0.48	0.58	0.68	0.80	0.94	1.09							
	8.2 lb/ft		.291	C	818	691	576	494	432	384	346	314	288	267	250	235							
				D	0.06	0.09	0.14	0.19	0.25	0.31	0.38	0.46	0.54	0.64	0.75	0.87							
	2"	D8202	.473	U	825	528	367	269	206	163	132	109	92	78	67	59	52	41					
				D	0.06	0.09	0.12	0.17	0.23	0.29	0.35	0.43	0.51	0.59	0.68	0.79	0.90	1.14					
	8.5 lb/ft		.434	C	818	818	818	737	644	573	516	496	430	397	368	344	322	286					
				D	0.03	0.06	0.09	0.13	0.18	0.23	0.28	0.33	0.40	0.47	0.55	0.63	0.71	0.90					
	3"	D8302	1.245	U	1047	942	654	480	368	291	235	195	163	139	120	105	92	73	59	49	41		
				D	0.03	0.06	0.10	0.13	0.18	0.22	0.27	0.33	0.39	0.45	0.53	0.61	0.69	0.88	1.07	1.31	1.55		
	9.3 lb/ft		.774	C	818	818	818	818	818	818	818	818	766	707	657	613	575	511	460	418	383		
				D	0.01	0.02	0.04	0.07	0.10	0.14	0.19	0.26	0.31	0.36	0.42	0.48	0.56	0.70	0.87	1.05	1.24		
Alum .100"	2"	D8200A	.573	U	514	329	229	168	129	102	83	69	58	49									
				D	0.16	0.25	0.36	0.48	0.61	0.79	0.97	1.18	1.40	1.65									
2.7 lb/ft		.525	C	537	537	537	460	402	353	323	299	269	249										
			D	0.09	0.15	0.28	0.39	0.50	0.63	0.78	0.93	1.12	1.31										

24 Inch Wide - 10 Diamond

PRODUCT DETAILS				CLEAR SPAN ^{FT}																			
Type	Depth Weight	Catalog Number	lx IN.4 Sx IN.3	U	24"	30"	36"	42"	48"	54"	60"	66"	72"	78"	84"	90"	96"	108"	120"	132"	144"		
Steel 14 GA	1-1/2"	D10154	.221	U	367	235	163	120	92	72	59	49	41	35	30								
				D	0.09	0.14	0.20	0.27	0.34	0.44	0.56	0.66	0.79	2.70	3.11								
	7.3 lb/ft		.247	C	571	571	489	419	367	326	293	267	245	226	210								
				D	0.06	0.10	0.15	0.21	0.28	0.35	0.44	0.53	0.62	2.16	2.51								
	2"	D10204	.427	U	539	345	240	176	135	106	86	71	60	51.00	44	38	34	27					
				D	0.05	0.09	0.13	0.17	0.23	0.29	0.35	0.43	0.51	0.60	0.69	0.78	0.90	1.18					
7.6 lb/ft		.363	C	571	571	571	571	539	479	431	392	359	332	308	287	270	240						
			D	0.02	0.05	0.08	0.12	0.18	0.24	0.29	0.35	0.41	0.48	0.55	0.64	0.72	0.92						
Steel 12 GA	1-1/2"	D10152	.299	U	496	317	220	162	124	98	79	66	55	47									
				D	0.08	0.13	0.18	0.25	0.32	0.41	0.50	0.61	0.72	0.86									
	10.1 lb/ft		.334	C	861	794	661	567	496	441	397	361	332	305									
				D	0.05	0.10	0.14	0.20	0.26	0.33	0.41	0.49	0.58	0.68									
	2"	D10202	.584	U	738	472	328	241	185	146	118	98	82	70	60	52	46						
				D	0.06	0.09	0.14	0.18	0.23	0.30	0.36	0.45	0.54	0.63	0.72	0.82	1.22						
	10.8 lb/ft		.497	C	861	861	861	843	738	656	590	537	492	454	422	394	369						
				D	0.03	0.06	0.09	0.14	0.18	0.24	0.29	0.36	0.42	0.50	0.57	0.67	0.76						
	3"	D10302	1.513	U	861	835	580	426	326	258	209	173	145	124	107	93	82	64	52	43	36		
				D	0.03	0.07	0.10	0.14	0.18	0.22	0.28	0.33	0.40	0.47	0.55	0.63	0.71	0.89	1.09	1.34	1.61		
	11.3 lb/ft		.879	C	861	861	861	861	861	861	861	861	861	861	861	861	861	861	861	861	861	861	861
				D	0.01	0.02	0.04	0.06	0.09	0.13	0.18	0.24	0.31	0.37	0.44	0.50	0.57	0.72	0.88	1.08	1.28		

Note:

- Strut deflection may become a limiting factor on 18" and 24" widths resulting in lower load values as indicated in tables.
- Web stiffeners can be supplied for ends and junctions of planks to even deflection if required.

DIAMOND-GRIP® WALKWAY

PRODUCT DESCRIPTION

Diamond-Grip® walkway is a one-piece metal plank grating manufactured by a cold forming process in the shape of an inverted channel. The web of the channel is the walking surface and has rough serrated edges around diamond shaped openings. Diamond openings are complete with radiused corners at the saddle and side channel location. The extended flanges support the load and provide a built in kickplate (toeboard).

FEATURES & BENEFITS

- Serrated edges around diamond shaped openings provide slip resistance under slippery conditions such as snow, ice, grease, oil, etc.
- Radiused corners reduce the possibility of stress cracks across saddles or at the side of channels under various loading conditions.
- Self-cleaning due to resilience of walking surface.
- One-piece metal construction complete with a full height toeboard on each side of the walking surface.
- Lightweight design provides high strength to weight ratio.
- Long life span requiring little maintenance.
- Simple and economical installation as walkways are self-framing.
- Adaptable to cost effective custom fabrication.

MATERIAL SPECIFICATIONS

Grating shall be "Diamond-Grip® walkway," manufactured from (**see 'Selections' below**) and complete with an (4-1/2", 5") integral toeboard, by AMICO.

SELECTIONS

- ASTM-A-653, G-90 (Z-275) pre-galvanized 14 or 12 gauge steel.
- ASTM-A-1011, HRP&O 14 or 12 gauge steel.

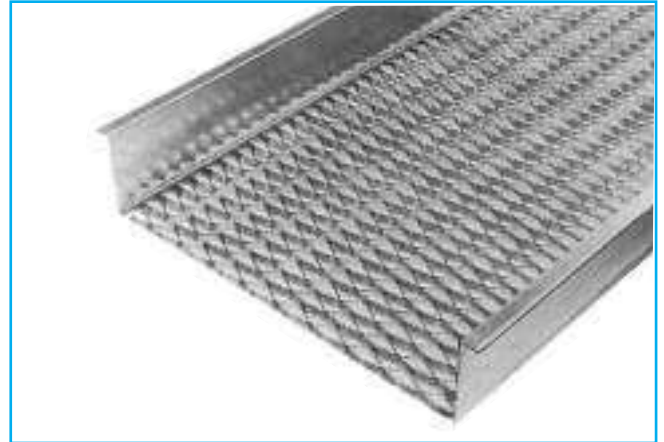

Safety Grating

DIAMOND-GRIP® WALKWAY

PRODUCT DETAILS

Type	Depth Weight	Catalog Number	Ix IN.4 Sx IN.3	CLEAR SPAN ^{FT}																		
				24"	30"	36"	42"	48"	54"	60"	66"	72"	78"	84"	90"	96"	108"	120"	132"	144"		
24" Wide 14 GA	4-1/2"	D10454W	1.447	U	300	300	300	300	300	263	213	176	145	124	110	94	84	67	55	44	37	
				D	0.50	0.51	0.52	0.55	0.58	0.55	0.49	0.46	0.45	0.43	0.47	0.46	0.51	0.58	0.67	0.75	0.87	
	8.9 lb/ft		.776	C	300	300	300	300	300	300	300	300	300	300	300	300	300	300	300	300	300	300
				D	0.40	0.40	0.40	0.41	0.42	0.43	0.44	0.46	0.48	0.50	0.53	0.56	0.60	0.69	0.80	0.95	1.10	
24" Wide 12 GA	4-1/2"	D10452W	2.457	U	475	475	475	475	475	429	348	287	240	203	177	150	135	107	87	71	60	
				D	0.45	0.46	0.47	0.49	0.52	0.51	0.47	0.43	0.42	0.41	0.43	0.43	0.48	0.54	0.62	0.72	0.84	
	12.5 lb/ft		1.171	C	475	475	475	475	475	475	475	475	475	475	475	475	475	475	475	475	475	475
				D	0.36	0.36	0.36	0.36	0.36	0.39	0.41	0.43	0.44	0.46	0.49	0.51	0.54	0.60	0.70	0.81	0.95	
24" Wide 14 GA	5"	D10504W	1.929	U	300	300	300	300	300	263	213	176	145	124	110	94	84	67	55	44	37	
				D	0.50	0.50	0.52	0.54	0.56	0.55	0.46	0.42	0.39	0.38	0.40	0.39	0.42	0.47	0.53	0.58	0.67	
	9.6 lb/ft		.917	C	300	300	300	300	300	300	300	300	300	300	300	300	300	300	300	300	300	300
				D	0.40	0.40	0.40	0.40	0.41	0.42	0.43	0.45	0.46	0.48	0.50	0.52	0.55	0.62	0.70	0.82	0.97	
24" Wide 12 GA	5"	D10502W	3.247	U	475	475	475	475	475	429	348	287	240	203	177	150	135	107	87	71	60	
				D	0.45	0.46	0.46	0.48	0.50	0.49	0.44	0.39	0.37	0.36	0.37	0.36	0.39	0.43	0.49	0.56	0.65	
	13.1 lb/ft		1.385	C	475	475	475	475	475	475	475	475	475	475	475	475	475	475	475	475	475	475
				D	0.36	0.36	0.36	0.36	0.37	0.38	0.40	0.41	0.42	0.43	0.44	0.47	0.49	0.55	0.61	0.69	0.80	

Explanation of Load Type

- U = uniform load (lb/ft²)
- D = corresponding deflection (in) resulting from uniform load
- C = concentrated load (lb)
- D = corresponding deflection (in) resulting from concentrated load

Note:

- All UDL and concentrated loads include a safety factor of 1.67.
- Strut deflection may become a limiting factor resulting in lower load values as indicated in table.

TECHNICAL DETAILS

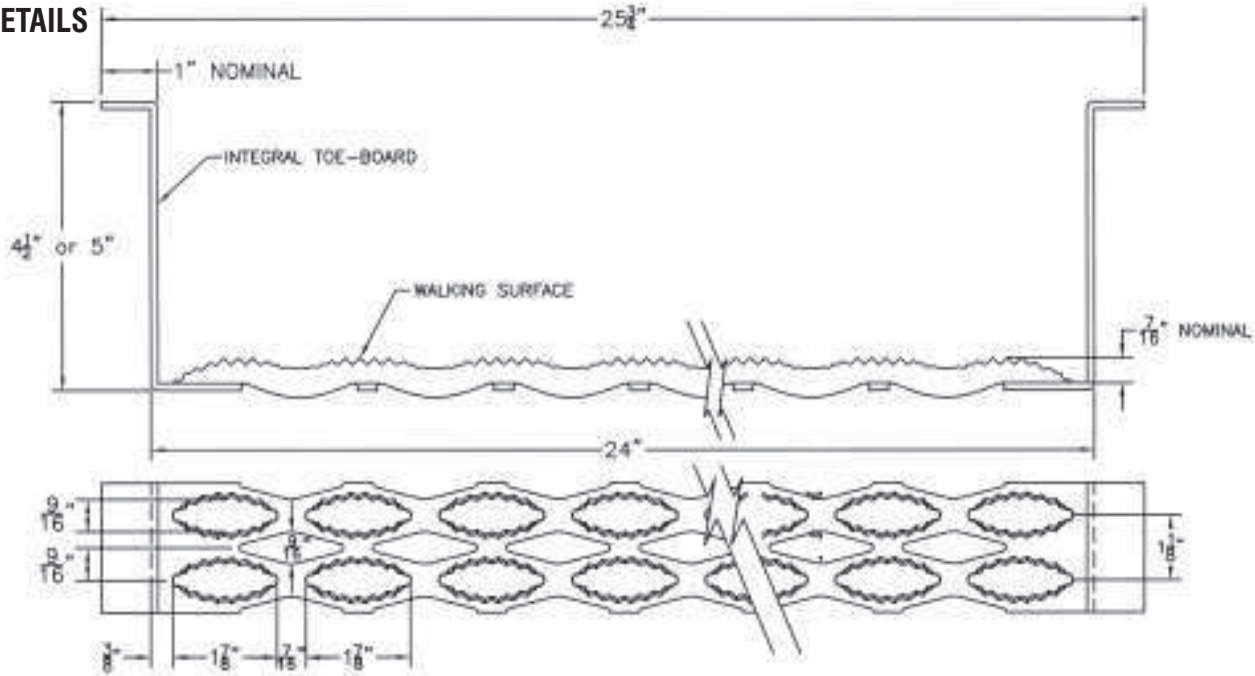

Note:

- Tolerances on all dimensions are $\pm 1/8$ "
- Standard lengths are 121 1/2" & 144".
- Tolerance on manufactured and cut lengths is $\pm 1/8$ ".
- When cutting Diamond-Grip®, AMICO® recommends cutting to full or half diamond increments.
- Camber is an expected condition with sheet metal products. While ASTM allowance is generous, AMICO attempts to lessen the effects. Normal clearances should offset this phenomenon, however where tolerances warrant, contact AMICO for clarification.

Safety Grating

SAFETY-GRIP®

PRODUCT DESCRIPTION

Safety-Grip® is a one-piece metal plank grating manufactured by a cold forming process in the shape of a channel. The web of the channel is the walking surface and has large debossed holes, surrounded by smaller embossed traction buttons.

FEATURES & BENEFITS

- Embossed traction buttons provide superior slip resistance in all directions and in all weather conditions.
- Large debossed holes provide maximum drainage of debris and allow up to 50% free air opening depending on channel width.
- Self-cleaning due to resilience of walking surface.
- One-piece metal construction.
- Lightweight design provides high strength to weight ratio.
- Long life span requiring little maintenance.
- Simple and economical installation as planks are self-framing.
- Adaptable to cost effective custom fabrication.
- Can be easily formed in standard channel or custom shapes.

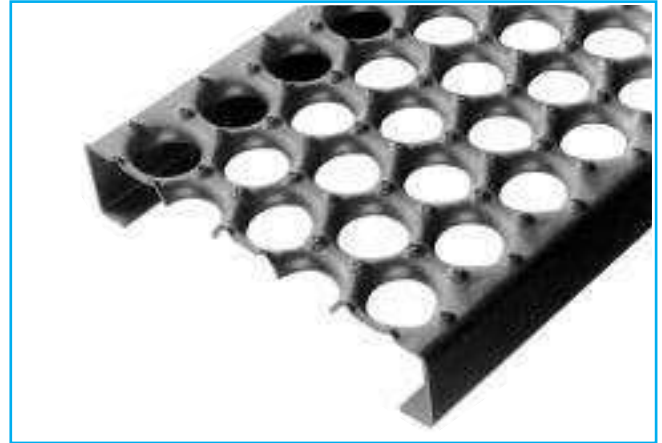

MATERIAL SPECIFICATIONS

Grating shall be "Safety-Grip® channel," manufactured from (**see 'Selections' below**) and complete with a (1-1/2", 2", 3") side channel depth, by AMICO.

SELECTIONS

- ASTM-A-653, G-90 (Z-275) Pre-galvanized 13 or 11 gauge steel.
- ASTM-A-1011, HRP&O 13 or 11 gauge steel.
- 5052H32 Aluminum .125" thick (up to 18" width).
- Type 316L 2B Stainless Steel 14 gauge (up to 12" width).
- Type 304L 2B Stainless Steel 16 gauge (up to 12" width).

CHANNEL WIDTH "A"	RETURN FLANGE "B"	Ø HOLE CHANNEL EDGE "C"
**5"	7/8"	1 21/32"
7"	1"	1 13/16"
10"	7/8"	1 5/8"
**12"	1"	1 25/32"
**18"	1"	1 13/32"
24"	1 1/18"	1 7/8"
30"	1 1/18"	2 11/32"

Note:

1. Tolerances on all dimensions are $\pm 1/8"$
2. End-hole pattern shown on diagram is even. Widths indicated with ** have a staggered end-hole pattern.
3. Outside traction buttons on all widths except 18" & 24" width.
4. Standard lengths are 120" and 144".
5. Tolerance on manufactured and cut lengths is $\pm 1/8"$.
6. Camber is an expected condition with sheet metal products. While ASTM allowance is generous, AMICO attempts to lessen the effects. Normal clearances should offset this phenomenon, however where tolerances warrant, contact AMICO for clarification.

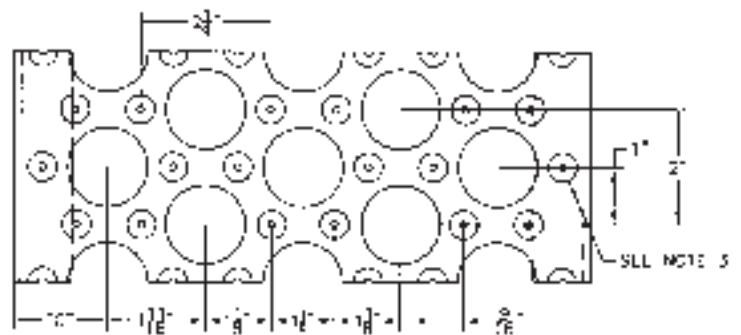

Safety Grating

LOAD & DEFLECTION TABLES

Explanation of Load Type

- U = uniform load (lb/ft²)
- D = corresponding deflection (in) resulting from uniform load
- C = concentrated load (lb)
- D = corresponding deflection (in) resulting from concentrated load

Note:

- All uniform and concentrated loads include a safety factor of 1.67.
- Spans and loads to the right of the bold line, based on loads indicated, may exceed deflections of L/120.

5 Inch Wide - 2 Hole

PRODUCT DETAILS				CLEAR SPAN ^{FT}																	
Type	Depth Weight	Catalog Number	lx IN.4 Sx IN.3	24"	30"	36"	42"	48"	54"	60"	66"	72"	78"	84"	90"	96"	108"	120"	132"	144"	
Steel 13 GA	1-1/2"	S2153	.228	U	1947	1248	868	639	490	388	315	261	220	188	163	142	126				
				D	0.06	0.10	0.14	0.19	0.25	0.32	0.39	0.48	0.57	0.67	0.78	0.90	1.03				
	2.6 lb/ft		.247	C	811	650	542	466	408	364	328	299	275	255	237	222	209				
				D	0.05	0.08	0.11	0.15	0.20	0.25	0.31	0.38	0.46	0.54	0.62	0.72	0.82				
	2"	S2203	.449	U	2943	1885	1311	964	739	585	475	393	331	283	245	214	188	150	122	102	86
				D	0.05	0.08	0.11	0.16	0.20	0.26	0.32	0.39	0.46	0.54	0.63	0.73	0.83	1.05	1.31	1.60	1.92
2.8 lb/ft		.372	C	973	973	819	703	616	549	495	451	414	383	357	334	314	281	255	233	216	
			D	0.03	0.06	0.09	0.12	0.16	0.21	0.25	0.31	0.37	0.43	0.50	0.58	0.66	0.84	1.05	1.28	1.54	
Alum .125"	2"	S2208A	.603	U	2479	1587	1102	809	620	490	397	328	275								
				D	0.08	0.12	0.17	0.24	0.31	0.39	0.49	0.59	0.70								
	1.3 lb/ft		.449	C	1033	826	689	590	516	459	413	379	344								
				D	0.06	0.10	0.14	0.19	0.25	0.32	0.39	0.47	0.56								
Stainless Steel 14 GA	2"	S2204S	.377	U	3295	2109	1464	1076	824	651	527	436	366	312	269	234					
				D	0.05	0.07	0.11	0.15	0.19	0.24	0.30	0.36	0.43	0.50	0.58	0.67					
	2.5 lb/ft		.312	C	1373	1098	915	784	686	610	549	499	458	422	392	366					
				D	0.04	0.06	0.09	0.12	0.15	0.19	0.24	0.29	0.34	0.40	0.47	0.53					

7 Inch Wide - 3 Hole

PRODUCT DETAILS				CLEAR SPAN ^{FT}																	
Type	Depth Weight	Catalog Number	lx IN.4 Sx IN.3	24"	30"	36"	42"	48"	54"	60"	66"	72"	78"	84"	90"	96"	108"	120"	132"	144"	
Steel 13 GA	1-1/2"	S3153	.260	U	1489	954	664	489	375	297	241	200	169	144	125	109	97				
				D	0.06	0.09	0.14	0.19	0.24	0.31	0.38	0.46	0.55	0.65	0.76	0.88	1.00				
	3 lb/ft		.277	C	793	696	581	499	437	390	352	321	295	274	255	239	225				
				D	0.04	0.08	0.11	0.15	0.19	0.25	0.31	0.37	0.44	0.52	0.61	0.70	0.80				
	2"	S3203	.509	U	2229	1428	993	731	560	444	360	298	251	215	186	162	143	114	93		
				D	0.05	0.08	0.11	0.15	0.20	0.25	0.31	0.37	0.45	0.52	0.61	0.70	0.80	1.02	1.27		
3.3 lb/ft		.415	C	793	793	793	746	654	582	525	479	440	407	379	355	334	299	271			
			D	0.02	0.05	0.08	0.12	0.16	0.20	0.25	0.30	0.36	0.42	0.49	0.56	0.64	0.82	1.02			
Steel 11 GA	1-1/2"	S3151	.330	U	1921	1231	856	630	483	382	310	257	217	185	160	140	124				
				D	0.06	0.10	0.14	0.19	0.24	0.31	0.38	0.47	0.56	0.65	0.76	0.88	1.00				
	4.2 lb/ft		.353	C	1098	897	749	643	564	502	453	413	379	351	327	306	288				
				D	0.05	0.08	0.11	0.15	0.20	0.25	0.31	0.37	0.44	0.52	0.61	0.70	0.80				
	2"	S3201	.655	U	2995	1918	1333	981	752	595	483	399	336	293	253	221	195	155	126	105	89
				D	0.05	0.08	0.12	0.16	0.21	0.27	0.34	0.41	0.49	0.56	0.62	0.71	0.81	1.03	1.28	1.56	1.87
4.5 lb/ft		.534	C	1098	1098	1098	1001	877	781	704	641	586	556	517	484	455	407	368	337	311	
			D	0.03	0.05	0.09	0.13	0.17	0.22	0.27	0.33	0.39	0.44	0.49	0.57	0.65	0.82	1.02	1.25	1.50	
3"	S3301	1.726	U	3765	3602	2503	1840	1410	1115	904	748	629	537	464	404	356	282	229	190	161	
			D	0.02	0.05	0.08	0.11	0.14	0.18	0.22	0.26	0.31	0.37	0.43	0.49	0.56	0.71	0.88	1.07	1.28	
4.8 lb/ft		.966	C	1098	1098	1098	1098	1098	1098	1098	1098	1098	1098	1018	946	885	831	741	669	611	563
			D	0.01	0.02	0.03	0.05	0.07	0.11	0.14	0.19	0.25	0.29	0.34	0.39	0.45	0.57	0.70	0.85	1.02	
Alum .125"	2"	S3208A	.686	U	1984	1270	882	648	496	392	317	262	220								
				D	0.08	0.13	0.19	0.25	0.33	0.42	0.52	0.63	0.75								
	1.5 lb/ft		.559	C	1157	926	771	661	579	514	463	421	386								
				D	0.06	0.10	0.15	0.20	0.27	0.34	0.42	0.50	0.60								
Stainless Steel 14 GA	2"	S3204S	.426	U	2148	1375	955	701	537	424	344	284	239	203	175						
				D	0.04	0.06	0.09	0.12	0.15	0.19	0.24	0.29	0.35	0.41	0.47						
	2.8 lb/ft		.348	C	1253	1002	835	716	626	557	501	456	418	385	358						
				D	0.03	0.05	0.07	0.09	0.12	0.16	0.19	0.23	0.28	0.32	0.38						

Safety Grating

LOAD & DEFLECTION TABLES

10 Inch Wide - 5 Hole

PRODUCT DETAILS				CLEAR SPAN ^{FT}																			
Type	Depth Weight	Catalog Number	Ix IN.4 Sx IN.3		24"	30"	36"	42"	48"	54"	60"	66"	72"	78"	84"	90"	96"	108"	120"	132"	144"		
Steel 13 GA	1-1/2"	S5153	.271	U	1128	722	501	368	282	223	181	149	125	107	92	80	71						
				D	0.06	0.09	0.13	0.17	0.23	0.29	0.35	0.42	0.50	0.57	0.65	0.75	0.87						
	3.5 lb/ft		.259	C	625	625	625	537	470	418	376	342	313	289	269	251	235						
				D	0.03	0.06	0.10	0.13	0.18	0.23	0.29	0.34	0.41	0.47	0.53	0.61	0.78						
	2"	S5203	.536	U	1500	1076	748	551	422	334	272	225	190	162	140	122	107	85	68	57	48		
				D	0.04	0.07	0.10	0.14	0.18	0.23	0.29	0.35	0.42	0.49	0.57	0.66	0.75	0.95	1.16	1.41	1.69		
3.9 lb/ft		.393	C	625	625	625	625	625	625	566	516	474	439	409	380	357	317	290	259	238			
			D	0.02	0.03	0.05	0.09	0.13	0.19	0.23	0.28	0.33	0.39	0.46	0.53	0.60	0.76	0.93	1.13	1.34			
Steel 11 GA	1-1/2"	S5151	.343	U	1343	861	599	441	338	268	218	180	152	130	113	98	87						
				D	0.06	0.09	0.13	0.18	0.23	0.29	0.36	0.44	0.53	0.62	0.72	0.84	0.95						
	4.5 lb/ft		.329	C	861	861	749	643	564	502	453	413	380	352	328	308	290						
				D	0.04	0.07	0.10	0.14	0.19	0.24	0.29	0.35	0.42	0.50	0.58	0.67	0.76						
	2"	S5201	.689	U	2067	1402	975	717	550	435	353	291	245	209	180	157	138	109	88	73	61		
				D	0.06	0.09	0.13	0.18	0.23	0.29	0.36	0.42	0.47	0.54	0.57	0.66	0.76	0.91	1.13	1.38	1.63		
4.8 lb/ft		.506	C	861	861	861	861	861	861	735	668	612	565	528	490	459	408	367	334	306			
			D	0.02	0.04	0.07	0.12	0.17	0.20	0.29	0.35	0.39	0.43	0.48	0.53	0.58	0.74	0.91	1.09	1.30			
3"	S5301	1.844	U	2067	2067	1816	1334	1021	807	654	540	454	387	334	291	255	202	163	135	113			
			D	0.02	0.04	0.07	0.11	0.13	0.17	0.21	0.26	0.31	0.36	0.42	0.48	0.54	0.70	0.84	1.03	1.22			
5.1 lb/ft		.938	C	861	861	861	861	861	861	861	861	861	861	861	861	861	851	757	681	619	567		
			D	0.01	0.01	0.02	0.04	0.06	0.08	0.11	0.14	0.19	0.24	0.30	0.36	0.44	0.55	0.68	0.83	0.98			
Alum .125"	2"	S5208A	.722	U	1278	871	605	445	341	269	218	181	152										
				D	0.08	0.14	0.20	0.28	0.36	0.46	0.57	0.68	0.82										
				C	533	533	533	533	533	505	455	414	380										
Stainless Steel 14 GA	2"	S5204S	.401	U	946	762	529	388	298	235	190	157	133										
				D	0.04	0.08	0.11	0.15	0.20	0.25	0.31	0.37	0.45										
				C	394	394	394	394	394	394	394	394	394	394	394	394	394	394	394	394	394	394	394
Stainless Steel 14 GA	3.2 lb/ft		.287	D	0.02	0.03	0.05	0.09	0.13	0.17	0.21	0.29	0.37										

12 Inch Wide - 6 Hole

PRODUCT DETAILS				CLEAR SPAN ^{FT}																			
Type	Depth Weight	Catalog Number	Ix IN.4 Sx IN.3		24"	30"	36"	42"	48"	54"	60"	66"	72"	78"	84"	90"	96"	108"	120"	132"	144"		
Steel 13 GA	1-1/2"	S6153	.350	U	991	635	442	326	250	198	161	134	113	97	84	74	65						
				D	0.05	0.08	0.12	0.17	0.22	0.28	0.34	0.42	0.50	0.58	0.68	0.78	0.89						
	4.3 lb/ft		.291	C	866	794	663	570	500	446	403	368	338	315	294	276	260						
				D	0.04	0.07	0.10	0.13	0.18	0.22	0.28	0.34	0.40	0.46	0.54	0.62	0.71						
	2"	S6203	.630	U	1457	934	649	478	367	290	236	195	165	141	122	107	94	75	61				
				D	0.04	0.07	0.10	0.13	0.17	0.22	0.27	0.33	0.40	0.47	0.54	0.63	0.71	0.91	1.14				
4.6 lb/ft		.437	C	866	866	866	836	733	653	590	538	494	458	427	400	376	338	307					
			D	0.02	0.04	0.07	0.11	0.14	0.18	0.22	0.27	0.32	0.37	0.43	0.50	0.57	0.73	0.91					
Steel 11 GA	1-1/2"	S6151	.406	U	1118	717	499	367	282	223	182	151	127	109	94	82	73						
				D	0.06	0.09	0.13	0.17	0.22	0.28	0.35	0.43	0.51	0.60	0.70	0.81	0.92						
	5.3 lb/ft		.373	C	1118	896	748	643	564	503	454	414	381	353	329	309	291						
				D	0.04	0.07	0.10	0.14	0.18	0.23	0.28	0.34	0.41	0.48	0.56	0.65	0.74						
	2"	S6201	.812	U	1875	1201	835	614	471	373	303	251	211	180	156	136	120	96	78	65	55		
				D	0.06	0.09	0.14	0.18	0.24	0.31	0.38	0.46	0.55	0.65	0.75	0.86	0.99	1.26	1.57	1.91	2.30		
5.5 lb/ft		.570	C	1362	1362	1253	1075	942	839	757	690	634	586	546	511	481	431	391	358	331			
			D	0.03	0.07	0.11	0.15	0.19	0.25	0.30	0.37	0.44	0.52	0.60	0.69	0.79	1.01	1.25	1.53	1.84			
3"	S6301	2.158	U	2725	2370	1647	1211	928	734	595	492	414	354	305	266	235	186	151	126	106			
			D	0.03	0.06	0.08	0.11	0.14	0.18	0.23	0.27	0.33	0.38	0.45	0.51	0.59	0.74	0.92	1.12	1.34			
6.2 lb/ft		1.045	C	1362	1362	1362	1362	1362	1362	1362	1362	1354	1243	1149	1069	999	939	838	757	692	632		
			D	0.01	0.02	0.04	0.06	0.09	0.12	0.17	0.22	0.26	0.31	0.36	0.41	0.47	0.60	0.74	0.90	1.07			
Alum .125"	2"	S6208A	.851	U	1245	797	554	407	312	247	200	165	139										
				D	0.09	0.15	0.21	0.29	0.38	0.48	0.59	0.72	0.86										
				C	839	839	831	713	624	555	500	455	417										
Stainless Steel 14 GA	2"	S6204S	.427	U	871	600	417	308	236	187	152	126	106										
				D	0.04	0.07	0.09	0.13	0.17	0.22	0.27	0.33	0.39										
				C	435	435	435	435	435	435	434	394	361										
Stainless Steel 14 GA	3.8 lb/ft		.313	D	0.02	0.03	0.05	0.09	0.13	0.19	0.25	0.30	0.36										

Safety Grating

LOAD & DEFLECTION TABLES

18 Inch Wide - 10 Hole

PRODUCT DETAILS				CLEAR SPAN ^{FT}																			
Type	Depth Weight	Catalog Number	Ix IN.4 Sx IN.3	24"	30"	36"	42"	48"	54"	60"	66"	72"	78"	84"	90"	96"	108"	120"	132"	144"			
Steel 13 GA	1-1/2"	S10153	.345	U	641	441	307	226	174	138	112	93	79	68	59	51	46						
				D	0.05	0.10	0.14	0.19	0.25	0.31	0.39	0.47	0.56	0.67	0.78	0.90	1.03						
	5.7 lb/ft		.292	C	480	480	480	480	480	466	421	385	355	327	304	284	266						
				D	0.02	0.04	0.08	0.12	0.18	0.25	0.31	0.38	0.45	0.53	0.61	0.71	0.80						
	2"	S10203	.677	U	641	641	460	339	260	206	168	139	117	100	87	76	67	53	43				
				D	0.03	0.07	0.11	0.15	0.19	0.24	0.30	0.36	0.43	0.51	0.60	0.69	0.79	1.01	1.26				
6.0 lb/ft		.440	C	480	480	480	480	480	480	480	480	480	480	480	480	480	426	399	355	319			
			D	0.01	0.02	0.04	0.06	0.09	0.13	0.18	0.24	0.32	0.40	0.48	0.55	0.62	0.78	1.06					
Steel 11 GA	1-1/2"	S10151	.444	U	752	482	336	247	190	151	123	102	86	74	64	56	50						
				D	0.06	0.09	0.13	0.17	0.23	0.29	0.36	0.44	0.52	0.62	0.72	0.83	0.95						
	6.8 lb/ft		.381	C	1116	904	755	649	570	509	460	420	387	359	335	315	297						
				D	0.04	0.07	0.10	0.14	0.18	0.23	0.29	0.35	0.42	0.49	0.58	0.67	0.76						
	2"	S10201	.894	U	1207	773	538	396	304	241	195	162	137	117	101	88	78	62	51				
				D	0.05	0.08	0.12	0.16	0.21	0.26	0.33	0.40	0.47	0.56	0.65	0.75	0.85	1.09	1.36				
7.1 lb/ft		.583	C	1116	1116	1116	1039	911	812	733	668	615	570	531	498	469	421	383					
			D	0.03	0.05	0.09	0.13	0.17	0.21	0.26	0.32	0.38	0.45	0.52	0.60	0.68	0.87	1.09					
3"	S10301	2.40	U	1488	1488	1153	847	649	512	415	343	288	246	212	184	162	128	104	86	72			
			D	0.02	0.04	0.07	0.10	0.13	0.15	0.19	0.23	0.27	0.32	0.37	0.43	0.48	0.61	0.76	0.92	1.08			
7.9 lb/ft		1.070	C	1116	1116	1116	1116	1116	1116	1116	1116	1116	1116	1116	1116	1038	973	865	778	708	649		
			D	0.01	0.01	0.20	0.04	0.06	0.08	0.11	0.14	0.19	0.24	0.30	0.34	0.39	0.49	0.60	0.73	0.87			
Alum .125"	2"	S10208A	.936	U	792	581	360	265	203	160	130	108	91	77									
				D	0.08	0.13	0.19	0.25	0.33	0.42	0.52	0.63	0.75	0.88									
2.8 lb/ft		.612	C	594	594	594	594	594	630	567	515	472	436										
			D	0.03	0.06	0.11	0.17	0.26	0.38	0.48	0.58	0.70	0.81										

24 Inch Wide - 13 Hole

PRODUCT DETAILS				CLEAR SPAN ^{FT}																		
Type	Depth Weight	Catalog Number	Ix IN.4 Sx IN.3	24"	30"	36"	42"	48"	54"	60"	66"	72"	78"	84"	90"	96"	108"	120"	132"	144"		
Steel 11 GA	2"	S13201	1.017	U	524	524	467	344	264	209	170	141	119	102	88	77	68	54	44			
				D	0.03	0.07	0.13	0.17	0.23	0.29	0.36	0.43	0.52	0.61	0.71	0.82	0.94	1.20	1.50			
	8.9 lb/ft		.634	C	524	524	524	524	524	524	524	524	524	524	524	524	524	524	489	445		
				D	0.01	0.02	0.04	0.06	0.09	0.13	0.18	0.24	0.31	0.39	0.48	0.60	0.72	0.96	1.20			
	3"	S13301	2.694	U	524	524	524	524	473	374	304	252	212	181	156	137	120	96	78	65	55	
				D	0.01	0.02	0.04	0.07	0.11	0.14	0.18	0.22	0.26	0.30	0.35	0.40	0.46	0.59	0.73	0.89	1.07	
9.8 lb/ft		1.149	C	524	524	524	524	524	524	524	524	524	524	524	524	524	524	524	524	524		
			D	0.00	0.01	0.01	0.02	0.03	0.04	0.05	0.07	0.08	0.11	0.13	0.17	0.20	0.29	0.39	0.52	0.68		

30 Inch Wide - 16 Hole

PRODUCT DETAILS				CLEAR SPAN ^{FT}																		
Type	Depth Weight	Catalog Number	Ix IN.4 Sx IN.3	24"	30"	36"	42"	48"	54"	60"	66"	72"	78"	84"	90"	96"	108"	120"	132"	144"		
Steel 11 GA	2"	S16201	1.985	U	275	275	275	251	231	183	148	122	103									
				D	0.02	0.04	0.09	0.17	0.24	0.31	0.38	0.47	0.56									
	11.8 lb/ft		.777	C	343	343	343	343	343	343	343	343	343									
				D	0.01	0.01	0.02	0.04	0.06	0.08	0.11	0.15	0.20									
	3"	S16301	2.728	U	275	275	275	275	275	251	219	181	152	130	112	97	86					
				D	0.01	0.01	0.03	0.06	0.09	0.13	0.18	0.22	0.26	0.32	0.36	0.42	0.45					
12.7 lb/ft		1.152	C	343	343	343	343	343	343	343	343	343	343	343	343	343						
			D	0.00	0.00	0.01	0.01	0.02	0.02	0.04	0.05	0.06	0.08	0.10	0.12	0.15						
4"	S16401	5.402	U	275	275	275	275	275	275	275	275	240	205	177	155	136	108	88	73	62		
			D	0.00	0.01	0.01	0.03	0.04	0.07	0.11	0.16	0.20	0.23	0.27	0.31	0.36	0.45	0.56	0.68	0.82		
13.5 lb/ft		1.769	C	343	343	343	343	343	343	343	343	343	343	343	343	343	343	343	343	343		
			D	0.00	0.00	0.00	0.01	0.01	0.01	0.02	0.02	0.03	0.04	0.05	0.06	0.07	0.10	0.14	0.19	0.24		

Note: Strut deflection may become a limiting factor on 18" and 24" widths resulting in lower load values as indicated in tables.

SAFETY-GRIP® WALKWAY

PRODUCT DESCRIPTION

Safety-Grip® walkway is a one-piece metal plank grating manufactured by a cold forming process in the shape of an inverted channel. The web of the channel is the walking surface and has large debossed holes, surrounded by smaller embossed traction buttons. The extended flanges support the load and provide a built in kickplate (toeboard).

FEATURES & BENEFITS

- Embossed traction buttons provide superior slip resistance in all directions and in all weather conditions.
- Large debossed holes provide maximum drainage of debris and allow up to 50% free air opening depending on channel width.
- Self-cleaning due to resilience of walking surface.
- One-piece metal construction complete with a full 5" toe-board height on each side of the walking surface.
- Lightweight design provides high strength to weight ratio.
- Long life span requiring little maintenance.
- Simple and economical installation as walkways are self-framing.
- Adaptable to cost effective custom fabrication.

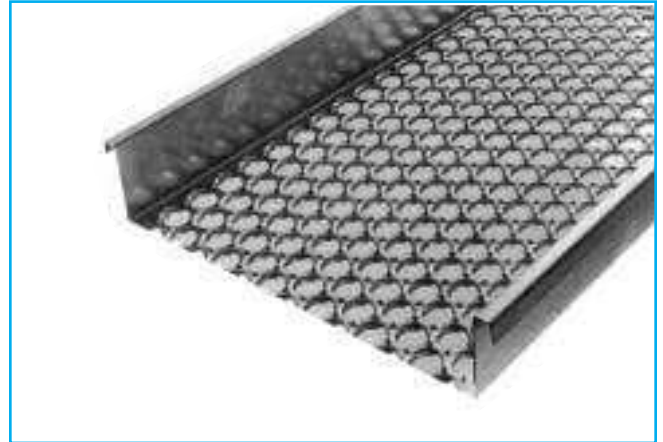

MATERIAL SPECIFICATIONS

Grating shall be "Safety-Grip® walkway," manufactured from (*see 'Selections' below*) and complete with an integral 5" toe-board, by AMICO.

SELECTIONS

- ASTM-A-653, G-90 (Z-275) pre-galvanized 13 or 11 gauge steel.
- ASTM-A-1011, HRP&O 13 or 11 gauge steel.



Safety Grating

SAFETY-GRIP® WALKWAY

PRODUCT DETAILS

Type	Depth Weight	Catalog Number	Ix IN.4 Sx IN.3	CLEAR SPAN ^{FT}																	
				24"	30"	36"	42"	48"	54"	60"	66"	72"	78"	84"	90"	96"	108"	120"	132"	144"	
24" Wide 13 GA	5"	S13503W	6.610	U	355	355	355	355	355	355	355	355	355	355	346	301	245	209	169	140	118
				D	0.00	0.00	0.01	0.02	0.03	0.05	0.07	0.10	0.15	0.20	0.26	0.30	0.35	0.44	0.53	0.65	0.78
	8.7 lb/ft	2.078	C	355	355	355	355	355	355	355	355	355	355	355	355	355	355	355	355	355	355
			D	0.00	0.00	0.00	0.00	0.01	0.01	0.01	0.02	0.02	0.02	0.03	0.04	0.05	0.07	0.09	0.12	0.16	
24" Wide 11 GA	5"	S13501W	9.968	U	657	657	657	657	657	657	657	657	619	528	455	396	348	275	223	104	155
				D	0.00	0.01	0.01	0.02	0.03	0.05	0.08	0.12	0.16	0.19	0.22	0.26	0.29	0.37	0.45	0.54	0.65
	11.8 lb/ft	2.880	C	657	657	657	657	657	657	657	657	657	657	657	657	657	657	657	657	657	657
			D	0.00	0.00	0.00	0.00	0.01	0.01	0.01	0.02	0.02	0.03	0.04	0.04	0.05	0.08	0.11	0.14	0.18	
30" Wide 11 GA	5"	S16501W	10.090	U	384	384	384	384	384	384	384	384	384	355	306	267	234	185	150	124	104
				D	0.00	0.01	0.01	0.02	0.04	0.06	0.09	0.16	0.20	0.23	0.26	0.30	0.34	0.45	0.55	0.66	0.78
	13.6 lb/ft	2.889	C	480	480	480	480	480	480	480	480	480	480	480	480	480	480	480	480	480	480
			D	0.00	0.00	0.00	0.00	0.01	0.01	0.01	0.02	0.02	0.03	0.04	0.05	0.06	0.08	0.11	0.15	0.19	
36" Wide 11 GA	5"	S18501W	N/A	U	185	185	185	185	185	185	185	185	185	185	185	185	185	158	128	106	89
				D	0.00	0.00	0.01	0.01	0.02	0.04	0.06	0.09	0.12	0.17	0.22	0.29	0.38	0.52	0.65	0.78	0.94
	15.9 lb/ft	N/A	C	273	273	273	273	273	273	273	273	273	273	273	273	273	273	273	273	273	273
			D	0.00	0.00	0.00	0.00	0.00	0.01	0.01	0.01	0.02	0.02	0.03	0.03	0.04	0.05	0.07	0.10	0.13	

Explanation of Load Type

- U = uniform load (lb/ft²)
- D = corresponding deflection (in) resulting from uniform load
- C = concentrated load (lb)
- D = corresponding deflection (in) resulting from concentrated load

Note:

- All uniform and concentrated loads include a safety factor of 1.67.
- Area in bold outline—contact AMICO for recommendations.
- Strut deflection may become a limiting factor resulting in lower load values as indicated in table.

TECHNICAL DETAILS

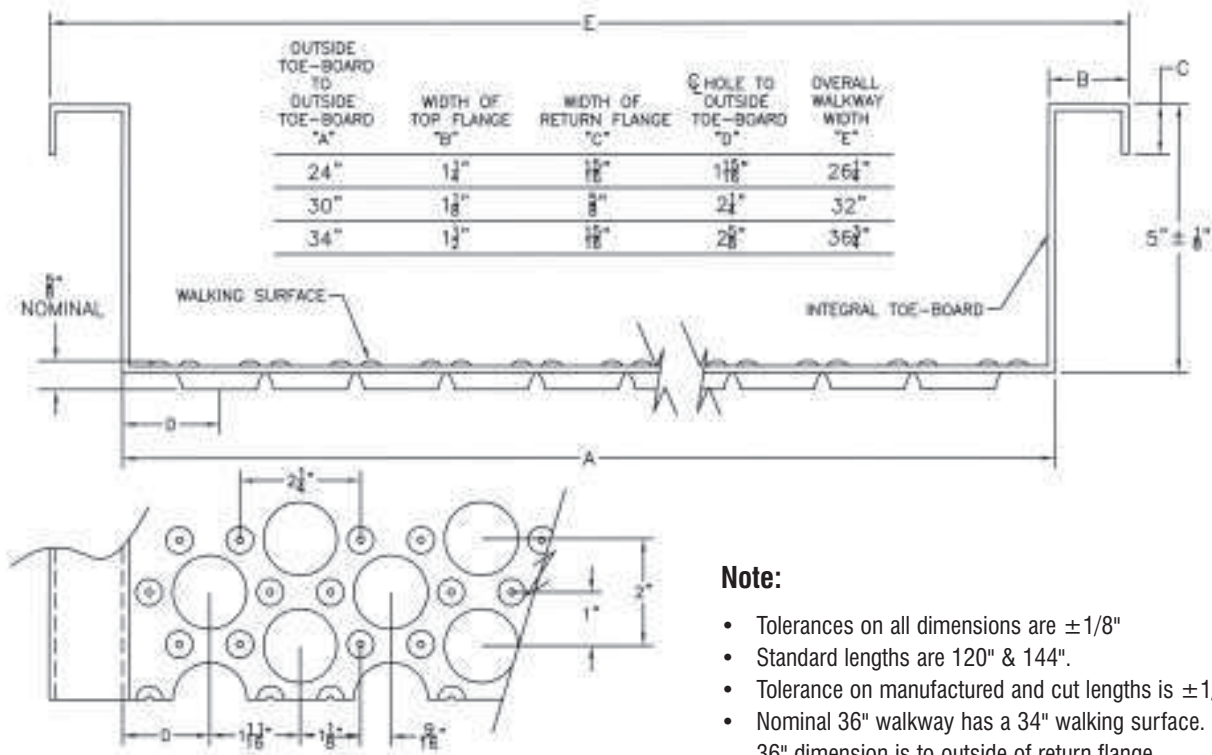

Note:

- Tolerances on all dimensions are ±1/8"
- Standard lengths are 120" & 144".
- Tolerance on manufactured and cut lengths is ±1/8".
- Nominal 36" walkway has a 34" walking surface. 36" dimension is to outside of return flange.

Camber is an expected condition with sheet metal products. While ASTM allowance is generous, AMICO attempts to lessen the effects. Normal clearances should offset this phenomenon, however where tolerances warrant, contact AMICO for clarification.

SAFETY-TREAD® CHANNEL

PRODUCT DESCRIPTION

Safety-Tread® channel is a one-piece plank grating manufactured by a cold forming process in the shape of a channel. The web of the channel is the walking surface which is covered with small perforated dimples.

FEATURES & BENEFITS

- Perforated dimples provide superior slip resistance in all directions. Quantity of dimples under foot provides exceptional adhesive friction.
- One-piece metal construction.
- Lightweight design provides high strength to weight ratio.
- Long effective life span requiring little maintenance.
- Can be easily formed in standard channel or custom shapes.
- Simple and economical installation as planks are self-framing.
- Adaptable to cost effective custom fabrication.
- Low projections and closed area provide an acceptable walking surface for industrial as well as institutional applications (i.e., women in heels can walk comfortably and safely).
- Available in four dimpled patterns (see opposite page for specifications).

MATERIAL SPECIFICATIONS

Standard Flooring Specification

Grating/Flooring to be Safety-Tread® channel (full, square, star, "V") pattern by AMICO manufactured from (*select one*):

- ASTM-A-1011, HRP&O, 13 or 11 gauge steel.
- ASTM-A-653, G-90 (Z-275) Pre-galvanized 13 or 11 gauge steel.
- 5052-H32 Aluminum, .125" thick
- Type 316L 2B Stainless Steel 14 gauge. ("V" pattern only)
- Type 304L Stainless Steel 16 gauge. ("V" pattern only)

Drainage Flooring Specification

Grating/Flooring to be Safety-Tread® drainage channel (square, star) pattern by AMICO manufactured from (select one):

- ASTM-A-1011, HRP&O, 13 or 11 gauge steel.
- ASTM-A-653, G-90 (Z-275) Pregalvanized 13 gauge steel.
- 5052-H32 Aluminum, .125" thick.

Safety Tread® channel and Safety-Tread® drainage channel are manufactured in nominal 10' and 12' lengths. Other combinations or gauges, channel depths, and widths are available by special request (see note on opposite page re: gauges).

Note:

1. Tolerances on all dimensions are $\pm 1/8"$
2. Camber is an expected condition with sheet metal products. While ASTM allowance is generous, AMICO attempts to lessen the effects. Normal clearances should offset this phenomenon, however where tolerances warrant, contact AMICO for clarification.

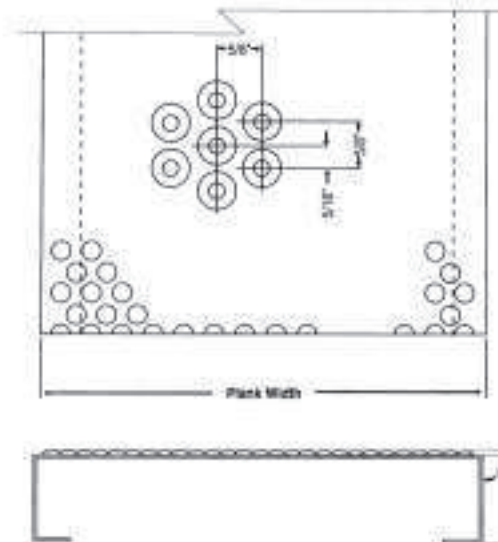

See next page for optional dimple patterns.

Safety Grating

SAFETY-TREAD® CHANNEL

Optional Dimpled Patterns

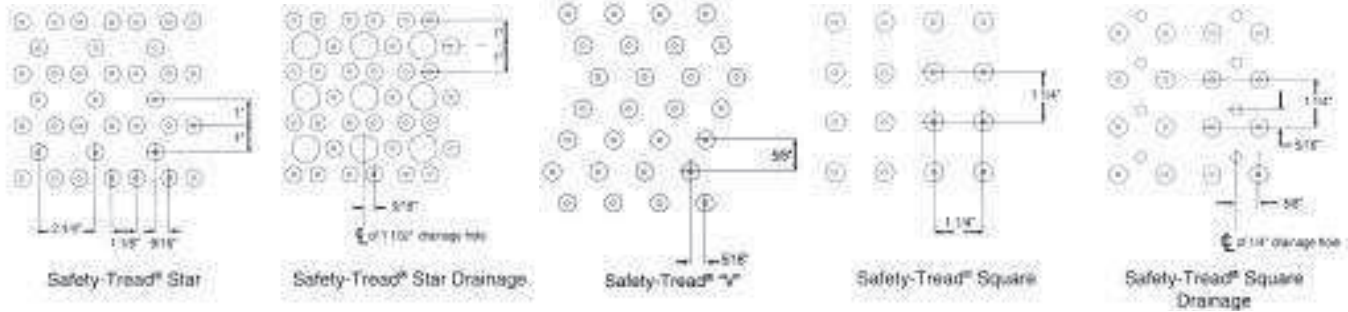

TECHNICAL DETAILS

LOAD & DEFLECTION TABLES

Explanation of Load Type

- U = uniform load (lb/ft²)
- D = corresponding deflection (in) resulting from uniform load
- C = concentrated load (lb)
- D = corresponding deflection (in) resulting from concentrated load

Note:

- All uniform and concentrated loads include a safety factor of 1.67.
- Shaded areas, based on loads indicated, may exceed deflections of L/120.

10 Inch Wide

PRODUCT DETAILS

Type	Depth Weight	Catalog Number	Ix IN.4 Sx IN.3	CLEAR SPAN ^{FT}																	
				24"	30"	36"	42"	48"	54"	60"	66"	72"	78"	84"	90"	96"	108"	120"	132"	144"	
Steel 13 GA	1-1/2"	TP5153	.272	U	1070	773	476	370	267	219	171	145	119	103	87	77	67				
				D	0.05	0.09	0.12	0.17	0.21	0.27	0.33	0.41	0.48	0.56	0.65	0.75	0.85				
				C	625	610	594	519	445	400	356	326	297	275	254	238	223				
	4.24 lb/ft	.267	D	0.03	0.06	0.10	0.14	0.18	0.22	0.27	0.33	0.39	0.45	0.52	0.60	0.69					
			U	1500	1108	716	560	404	332	261	221	182	158	134	118	102	80	65			
			D	0.04	0.08	0.10	0.14	0.17	0.22	0.27	0.33	0.39	0.47	0.54	0.62	0.70	0.88	1.08			
4.84 lb/ft	.404	C	625	625	625	625	625	582	539	494	449	418	387	359	332	300	274				
		D	0.02	0.03	0.05	0.09	0.13	0.18	0.22	0.27	0.32	0.38	0.44	0.50	0.56	0.72	0.91				
		U	1343	971	599	468	338	278	218	185	152	132	113	100	87						
Steel 11 GA	1-1/2"	TP5151	.343	U	1343	971	599	468	338	278	218	185	152	132	113	100	87				
				D	0.06	0.10	0.13	0.19	0.23	0.30	0.37	0.45	0.53	0.63	0.73	0.85	0.96				
				C	861	805	749	656	564	508	453	416	380	354	328	309	290				
	5.54 lb/ft	.369	D	0.04	0.08	0.11	0.15	0.19	0.24	0.29	0.36	0.43	0.51	0.59	0.68	0.77					
			U	1881	1366	851	676	501	410	320	271	223	194	164	145	126	99	80			
			D	0.04	0.07	0.10	0.15	0.19	0.25	0.30	0.37	0.43	0.51	0.58	0.67	0.76	0.96	1.18			
5.95 lb/ft	.511	C	861	861	861	861	861	757	681	624	568	527	487	456	426	378	340				
		D	0.02	0.04	0.06	0.11	0.16	0.20	0.24	0.29	0.35	0.41	0.48	0.55	0.62	0.78	0.97				
		U	1881	1366	851	676	501	410	320	271	223	194	164	145	126	99	80				

12 Inch Wide

PRODUCT DETAILS

Type	Depth Weight	Catalog Number	Ix IN.4 Sx IN.3	CLEAR SPAN ^{FT}																	
				24"	30"	36"	42"	48"	54"	60"	66"	72"	78"	84"	90"	96"	108"	120"	132"	144"	
Steel 13 GA	1-1/2"	TP6153	.320	U	991	716	442	346	250	205	161	137	113	97	82	72	63				
				D	0.05	0.09	0.12	0.17	0.21	0.27	0.33	0.41	0.48	0.57	0.65	0.75	0.85				
				C	866	764	663	581	500	451	403	370	338	312	287	269	251				
	4.83 lb/ft	.302	D	0.04	0.07	0.10	0.14	0.18	0.23	0.28	0.34	0.40	0.47	0.55	0.63	0.72					
			U	1457	1053	649	508	367	301	236	200	165	143	122	108	94	75	60			
			D	0.04	0.08	0.10	0.14	0.17	0.23	0.27	0.33	0.39	0.47	0.54	0.63	0.71	0.90	1.04			
5.13 lb/ft	.453	C	866	866	866	800	733	661	590	542	494	460	427	401	376	335	300				
		D	0.02	0.04	0.07	0.11	0.14	0.18	0.22	0.27	0.32	0.38	0.44	0.51	0.58	0.73	0.90				
		U	1118	808	499	390	282	232	182	154	127	110	94	83	72						
Steel 11 GA	1-1/2"	TP6151	.406	U	1118	808	499	390	282	232	182	154	127	110	94	83	72				
				D	0.06	0.10	0.12	0.18	0.22	0.29	0.35	0.43	0.50	0.60	0.69	0.81	0.93				
				C	1118	933	748	656	564	509	454	418	381	355	329	310	291				
	6.33 lb/ft	.376	D	0.05	0.08	0.11	0.15	0.19	0.25	0.30	0.37	0.44	0.52	0.60	0.69	0.79					
			U	1875	1201	835	614	471	373	303	251	211	180	156	136	120	96	78			
			D	0.06	0.09	0.13	0.18	0.24	0.31	0.39	0.46	0.55	0.64	0.75	0.86	0.99	1.27	1.57			
6.79 lb/ft	.571	C	1362	1362	1253	1075	942	839	752	690	634	586	546	511	481	431	391				
		D	0.03	0.07	0.11	0.15	0.20	0.25	0.31	0.38	0.45	0.53	0.62	0.71	0.82	1.04	1.297				
		U	1875	1201	835	614	471	373	303	251	211	180	156	136	120	96	78				

Note: Due to the low profile of the walking surface, 11 gauge material is recommended to help reduce strut deflection.

Safety Grating

SAFETY-TREAD® FLOORING

PRODUCT DESCRIPTION

Safety-Tread® is a metal flooring product which is covered with small perforated dimples manufactured by a cold forming process.

OPTIONAL FEATURE:

Safety-Tread® flooring is available in two drainage patterns which incorporate embossed holes (staggered) between raised dimples.

FEATURES & BENEFITS

- Perforated dimples provide superior slip resistance in all directions and in all weather conditions. The quantity of dimples under foot provides exceptional adhesive friction.
- Long life span requiring little maintenance.
- Can be easily formed into custom shapes.
- Adaptable to wide range of applications.
- Easily adaptable to cost effective, custom fabrication.
- Low projections and closed area provide an acceptable walking surface for industrial as well as institutional and commercial application (i.e., women in heels can walk comfortably and safely).
- Available in four dimpled patterns
- Optional drainage flooring features smaller unembossed holes (location and size variable with dimple pattern) providing drainage for liquid which may pool on walking surface in wet environments.

MATERIAL SPECIFICATIONS

Standard Flooring Specification

Grating shall be "Safety-Tread® flooring," (full, square, star, "V") pattern by AMICO manufactured from (***select one***):

- ASTM-A-1011, HRP&O, 16, 13 or 11 gauge steel.
- ASTM-A-653, G-90 (Z-275) Pre-galvanized 13 gauge steel.
- 5052H32 Aluminum, .125" thick.
- Type 316L, Stainless Steel 14 gauge ("V" pattern only)
- Type 304L, Stainless Steel 16 gauge ("V" pattern only)

Drainage Flooring Specification

Flooring shall be Safety-Tread® drainage flooring (square, star) pattern by AMICO manufactured from (***select one***):

- ASTM-A-1011, HRP&O, 11 gauge steel.
- ASTM-A-653, G-90 (Z-275) Pre-galvanized 13 gauge square pattern or 11 gauge star pattern.
- 5052H32 Aluminum, .125" thick.

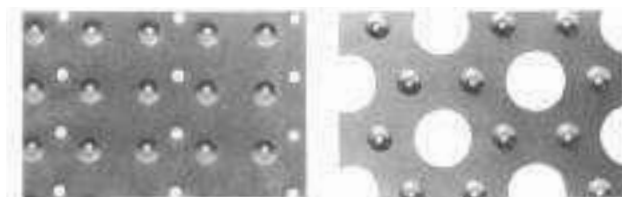
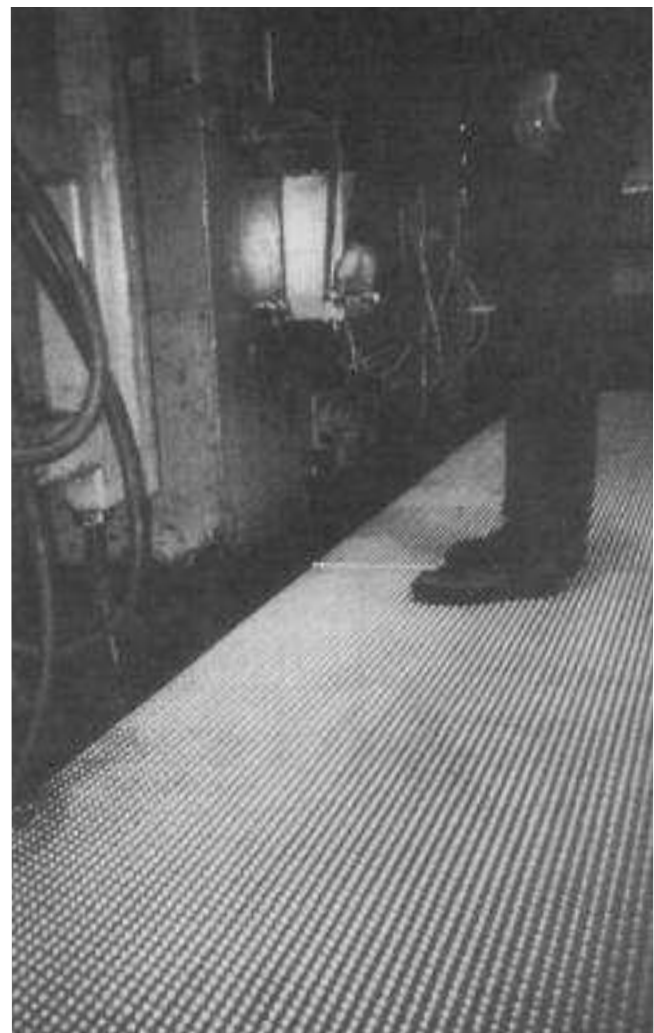
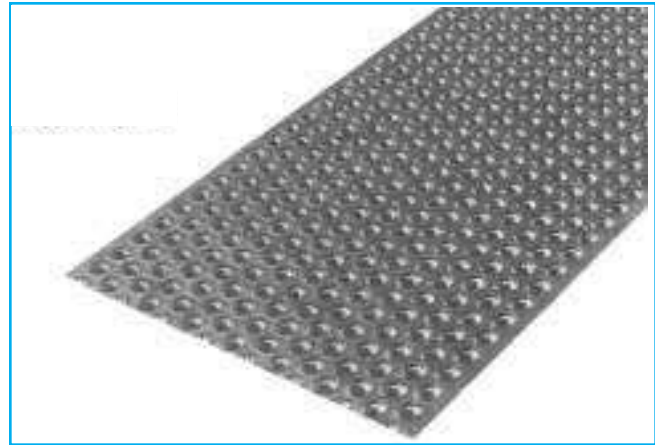

SQUARE DRAINAGE

STAR DRAINAGE

Safety Grating

SAFETY-TREAD® LADDER RUNGS

PRODUCT DESCRIPTION

Safety-Tread® ladder rungs are small channel shaped sections; the web of the channel being the walking surface which is covered with small perforated dimples, produced by a cold forming process.

FEATURES & BENEFITS

- Perforated dimples provide superior slip resistance in all directions and in all weather conditions. The quantity of dimples under foot provides exceptional adhesive friction.
- Cross sectional design provides significant load carrying capacity on spans up to 24".
- Three widths of rung to choose from.
- Leading row of dimples projected on the edge of the rung provides slip resistance to the foot approaching at an angle to the walking surface.
- Long life span requiring little maintenance.
- Adaptable to a wide range of applications.
- Easily adaptable to cost effective, custom fabrication.
- Ideal for retrofit applications as rungs fit over slippery pipes, bars, etc. on existing ladders.

MATERIAL SPECIFICATIONS

Ladder rungs shall be "Safety-Tread® ladder rungs," manufactured from (see 'Selections' below) by AMICO.

SELECTIONS

- ASTM-A-1011, 13 or 11 gauge, HRP&O steel.
- ASTM-A-653, 13 gauge, G-90 (Z-275) Pre-galvanized steel.
- 5052H32 .125" thick, Aluminum.
- Type 316L, 14 gauge Stainless Steel.

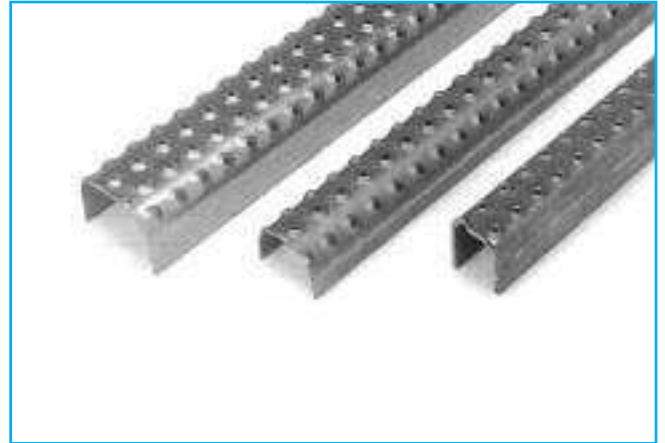

Safety Grating

SAFETY-TREAD® LADDER RUNGS

TECHNICAL DETAILS

1 1/4" Wide (2 Hole)

Type	Weight lb./ft.	Catalog Number	Load Type	Clear Span			
				16"	18"	20"	24"
Steel 11 GA	1.2	LR1251B	C	377	339	308	265
			D	0.014	0.018	0.025	0.036
Stainless Steel 14 GA	1.0	LR1254B					
Aluminum .125"	0.52	LR1258A		Available by request.			

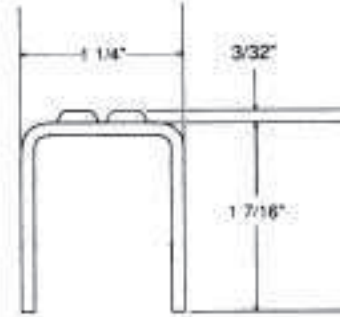

1 5/8" Wide (3 Hole)

Type	Weight lb./ft.	Catalog Number	Load Type	Clear Span			
				16"	18"	20"	24"
Steel 13 GA	1.3	LR6253B	C	260	230	200	175
			D	0.020	0.029	0.037	0.065
Stainless Steel 14 GA	1.1	LR6254S	C	280	250	225	185
			D	0.044	0.051	0.065	0.080
Aluminum .125"	0.5	LR6258A	C	240	214	193	161
			D	0.069	0.085	0.099	0.137

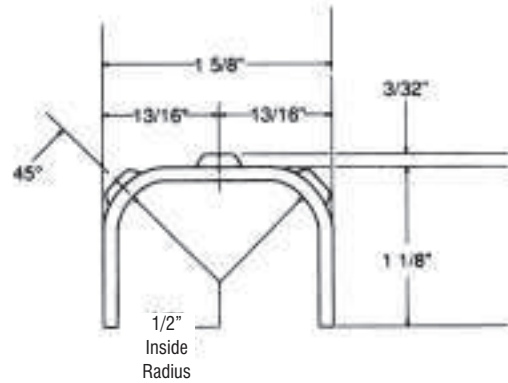

2 1/4" Wide (4 Hole)

Type	Weight lb./ft.	Catalog Number	Load Type	Clear Span			
				16"	18"	20"	24"
Steel 13 GA	1.5	LR2253B	C	490	440	400	345
			D	0.032	0.045	0.050	0.065
Stainless Steel 14 GA	1.2	LR2254S	C	415	375	340	290
			D	0.020	0.029	0.040	0.050
Aluminum .125"	0.52	LR2258A	C	390	350	320	255
			D	0.280	0.041	0.050	0.067

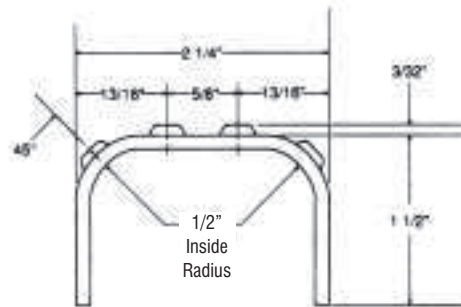

Explanation of Load Type

- C = concentrated load (lb)
- D = corresponding deflection (in) resulting from concentrated load

Note:

- All concentrated loads include a safety factor of 1.67.
- Tolerance on all dimensions $\pm 1/8"$
- Standard lengths are 5'0".

Safety Grating

DIAMOND-GRIP®

PRODUCT DESCRIPTION

Stair treads are fabricated from AMICO standard Safety-Grip®, Diamond-Grip® and Safety-Tread® channel planks (see product specification sheets for technical details). All treads are complete with end plates welded to each end for easy connection to stringers or are available with open ends.

Treads are available from stock in sizes indicated below or can be custom fabricated from any channel product and in any material including G90 galvanized, HRP&O, aluminum and stainless steel.



Diamond-Grip® Treads

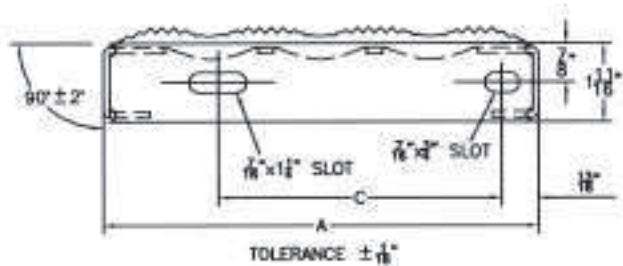

"A" TREAD DEPTH (CHANNEL WIDTH)	CARRIER PLATE WIDTH	DIMENSION "C"
4 3/4"	4 1/2"	2 1/8"
7"	6 3/4"	3 1/2"
9 1/2"	9 1/4"	6 1/16"
11 3/4"	11 1/2"	8 3/8"

For use with 1 1/2" or 2" heights

Standard Stock Sizes of Diamond-Grip® Stair Treads:

- D415424E 24"(W) x 9 1/2"(D) x 1 1/2" (H)
- D415430E 30"(W) x 9 1/2"(D) x 1 1/2" (H)
- D415436E 36"(W) x 9 1/2"(D) x 1 1/2" (H)

Safety-Grip®/Safety-Tread® Treads

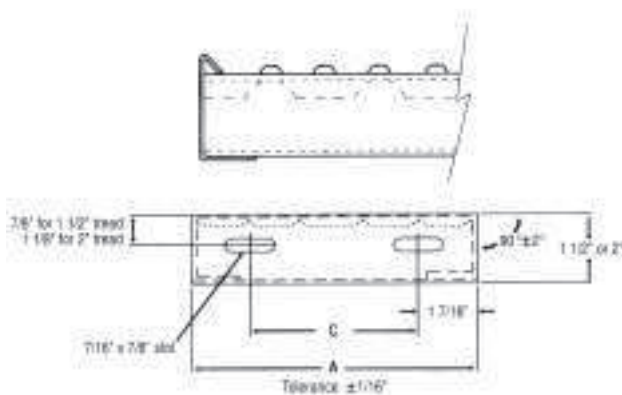

"A" TREAD DEPTH (CHANNEL WIDTH)	CARRIER PLATE WIDTH	DIMENSION "C"
5"	4 7/8"	2 1/8"
7"	6 7/8"	4 1/8"
10"	9 7/8"	7 1/8"
12"	11 7/8"	9 1/8"
18"	17 7/8"	15 1/8"

For use with 1 1/2" or 2" heights

Standard Stock Sizes of Safety-Grip® Stair Treads:

- S515324E 24"(W) x 10"(D) x 1 1/2" (H)
- S515330E 30"(W) x 10"(D) x 1 1/2" (H)
- S515336E 36"(W) x 10"(D) x 1 1/2" (H)

Safety Grating

INSTALLATION ACCESSORIES

SAFETY-GRIP® BOLT SEATS

Safety-Grip® planks can be mechanically fastened to a structural support by using specially designed Bolt Seats which seat within the large debossed holes, below the walking surface. Bolt Seats have an oblong hole to accommodate a 3/8" bolt, and are available in:

- 11 ga., G90 Galvanized (H12264)
- .125" Aluminum (H12264A)
- 316L Stainless (H12264S)

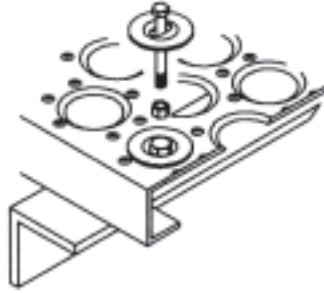

DIAMOND-GRIP® BOLT SEATS

Diamond-Grip® planks can be mechanically fastened to a structural support by using specially designed Bolt Seats which seat in between the raised diamonds below the walking surface. Bolt Seats have a round hole to accommodate a 3/8" bolt, and are available in:

- 12 ga., G90 Galvanized (H12262)
- .125" Aluminum (H12262A)
- Stainless (H12262S) by special request only.
- Optional square hole in bolt seat to accommodate 5/16" carriage bolt available by special request (H12262SQ)



MID-SUPPORT CLIP ASSEMBLY

Between structural supports it may be necessary to tie planks together to minimize relative deflection. This is accomplished by using a Mid-Support Clip which draws the plank's side channels together by applying pressure between the bolts and the clip edge (clip no. MSCL).

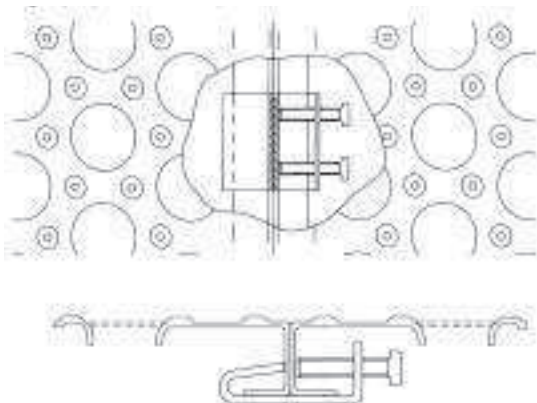

"J" CLIP ASSEMBLIES

In order to alleviate the necessity of drilling a hole through a structural member, a Bolt Seat and "J" Clip assembly can be used. The friction connection is accomplished by wedging the grating between the Bolt Seat and structural support, by applying pressure to the underside of the flange of the supporting steel (clip no. H12296). Not recommended in areas subject to vibration.

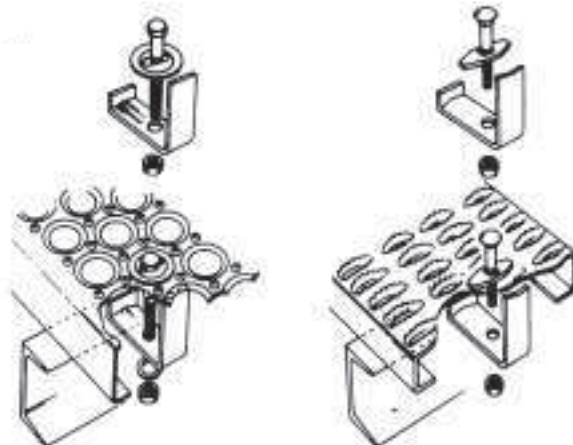

Safety Grating

OVER SUPPORT—SPLICE PLATE KIT

Notes:

- This kit is intended to splice two sections of walkway together OVER A SUPPORT ONLY.
- The walkway kit includes two splice plates with slotted holes and 16 fastener sets.
- Holes in the grating walkway are not provided by AMICO and are to be field drilled.

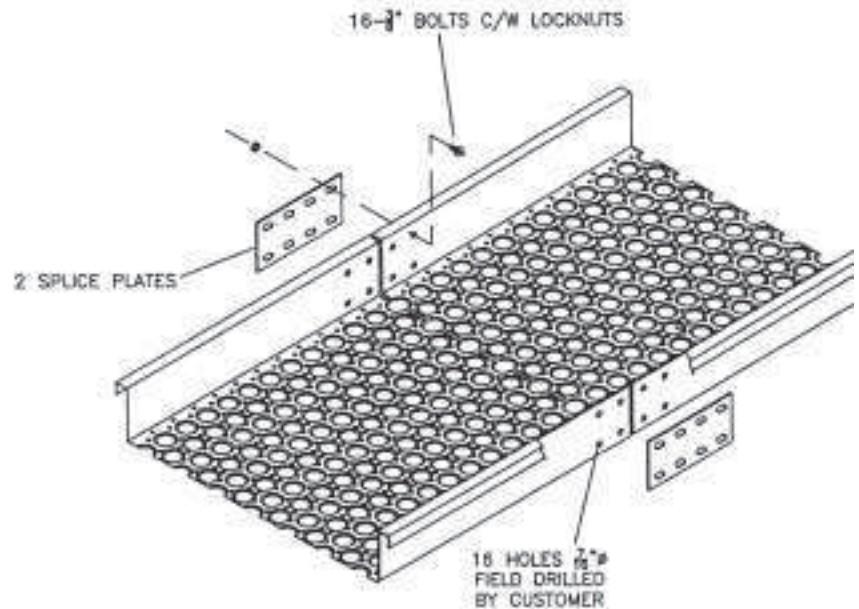

BETWEEN SUPPORT—SPLICE PLATE KIT

Notes:

- This kit is intended to splice two sections of any width of walkway together between supports.
- The walkway kit includes one wrap around plate with fastening hardware for walking surface and side channel connection. The fastener points should be staggered evenly across the plank width on each side of the splice. The side channel (kick plate) connection utilizes four slots provided in the splice flange.
- Holes in the grating walkway are not provided by AMICO and are to be field drilled.

